

Gas Sensor Calibration Manual
For All Foxcroft Equipment & Service Co. Gas Sensors

Table of Contents

General Information	Page
Gas exposure, Serial Number, Humidity, Temperature	4
Maximum Overload, Sensor Zero Point Drift	5
Calibration Frequency	6
Setting the Zero Point	7
Full Calibration, Toxic Gas Sensors	9
Calibration, Oxygen Sensors	10
Calibration, Ready Advanced Ammonia, Ozone, Hydrogen Cyanide Sensors	11
Sensor Response (Bump) Test	12
Gas Sensor Replacement, Citicel	13
Gas Sensor Components	14
Gas Sensor Replacement Ready Advanced	15

Gas Sensors

General Information

The responsiveness of electrochemical sensors will vary with environmental conditions. Sensor response may be higher or lower depending on actual environmental conditions.

Gas Exposure

The electrochemical gas sensors used in FX-1500v4 gas detectors are strictly designed and intended for occasional intermittent exposure to the target gas. Under no circumstances will the sensor survive continuous exposure to target gas. The only exception to this is Oxygen sensors.

Sensor Serial Number and Date Code

Each gas sensor has an eight digit serial number followed by a 3 digit date code. The first two digits of the date code signify the month, the third is the year of shipment from the factory.

Humidity

Gas sensors are relatively unaffected by humidity if conditions are not condensing within a range of 15% to 90% RH. The sensor will show a transient response to rapid changes in humidity which should go away after 30 seconds.

The gas sensor includes an aqueous electrolyte and a porous diffusion barrier. This means the sensor can both absorb water from the atmosphere and dry out. At continuous operation at high temperatures and 90%-100% RH the sensor can become prone to leakage as the free space in the sensor slowly fills with water. The sensor can gradually be restored to balance without permanent damage by exposure to lower relative humidity.

Likewise, continuous operation at 0-15%RH will cause the sensor to dry out, which can cause the acid electrolyte to attack the seals. This occurs if the volume of electrolyte decreases by more than 40%. If not left in this condition too long the sensor can be restored by exposing the sensor to RH humidity above 15%.

Temperature

Both the baseline (zero point) and output span are affected by temperature. The baseline approximately doubles with every 10°C increase in temperature. The output span will increase slightly up to about 10% before leveling off with gradual increase in temperature. A transient spike can occur with rapid changes in temperature; this should go away after 30 seconds.

Gas Sensors, General Information continued

Maximum Overload

The gas sensor maximum overload rating, for chlorine it is 250 ppm, is specified in terms of maintaining a linear response over a 10-minute exposure and recovering quickly. At higher levels the sensor will progressively become more non-linear and take increasingly longer to recover as the sensing electrode is unable to consume all the gas diffusing to it.

If the gas level is increased even further gas will build up inside the sensor and diffuse into the internal spaces where it may interact with the reference electrode, altering its potential. If this happens the sensor may take several days to recover once placed in clean air.

Sensor Zero Point Drift

Over time all gas sensors will experience a shift of the zero, or reference point. When this happens the gas concentration readings will also shift accordingly, producing inaccurate readings.

Note that sensor responsiveness will vary with environmental conditions.

Typically gas exposure mentioned throughout this document refers to the target gas, however exposure to interfering gases can cause similar effects as target gas exposure.

Causes of gas sensor zero point drift include:

- Chemical degradation of the sensor over time.
- Temperature, affecting both the span and zero point
- Repeated use in extreme high or low temperature or humidity conditions, or environments with high levels of airborne particles. Temperatures above the rated limit stress the seals, which will cause electrolyte leakage.
- Exposure to high levels of gas, or exposure to concentrations that exceed the range of the sensor.
- Low level gas exposure for extended periods of time.
- Continuous exposure to solvent vapors or highly corrosive gases.
- Rough handling or jolting of the sensor and electronics

Exposure to these conditions may damage the sensor to the point that it can no longer operate properly over its full range or be able to calibrate properly.

Calibration

Calibration Frequency

The only way to guarantee that an instrument will detect gas accurately and reliably is to test it with a known concentration of gas. Regular testing and calibration is the only way to be certain that a detector is fully functional. Testing with a milliamp generator is not a true, valid test.

A calibration or gas sensor can only be as accurate as the test gas used to perform the calibration.

1. The gas sensor should undergo a sensor response, or bump test, at least once per month. If the sensor fails the bump test then full calibration is required.
2. The gas sensor should undergo a full calibration at least once every 6 months and after the sensor detects a gas leak.

NOTE: A sensor may require more frequent calibration depending on the effects of local conditions such as temperature, humidity, presence of gas or vapors that can poison the sensor, or by local regulations.

3. It is important to keep a log of sensor tests, calibrations and results.

CAUTION: Although it is common for operators to test chlorine sensor response with bleach, pool chlorinating chemicals, or by producing chlorine gas by mixing bleach with an acid, doing so risks exposing the gas sensor to excessively high concentrations that can damage the gas sensor.

WARNING: NEVER attempt to calibrate a chlorine gas sensor with bleach, pool chlorinating chemicals, or by producing chlorine gas with a mixture of bleach and an acid. Any sensor adjustment made with such gases or fumes, or without the proper known concentration of gas will cause the sensor to not alarm at all or to alarm at incorrect and unsafe levels. This can create a life threatening situation in which the detector may not alarm during a chlorine gas leak.

Calibration

Setting the Zero Point

The gas sensor zero point will drift over time with changes in temperature, humidity and after a gas leak.

The shift may only be off only slightly or enough to trigger the cell failure or caution alarms. If this has happened to your gas detector, and the reading (or alarm) is stable, you can usually correct the problem with a slight zero adjustment. If the reading is erratic, either there is a gas leak that the sensor is picking up, or the detector is in need of service. Chlorine sensors are stated to have a maximum zero drift of -0.2 ppm equivalent at +20°C to +40°C.

The zero adjustment is done on the sensor itself in ambient air free of the target gas or any interfering gases. Be sure that you don't have any minor gas leaks that would affect the zero setting before performing this adjustment.

The room where the gas sensor is mounted and where the zero point is adjusted should not contain any other forms of chlorine, including calcium hypochlorite, sodium hypochlorite, or various cleaning chemicals and solvents that may or may not contain chlorine. The gas sensor is extremely sensitive and will pickup these sources of chlorine, which will offset the zero calibration to an incorrect value.

To Set the Zero Point:

You will need a millivolt meter, the blue test connector with leads shipped with your detector and a flat blade jeweler's screwdriver. The detector should be powered up. You may also use the detector display for calibration.

1. Remove the cover from the gas sensor enclosure. You may leave the sensor in the housing or remove it for easier access by unscrewing the mounting ring and pulling the sensor out of the enclosure.

NOTE: Use the orange connector or the gray plastic sensor body to handle the gas sensor. Do not handle the sensor using the mA transmitter circuit board to avoid damage to the board by static electricity.

	<p>CAUTION: the printed circuit board is sensitive to Electro-Static Discharge. It can be irreparably damaged by static electricity, causing partial or total operational failure. You must take the following precautions before <i>touching or making any connections to the circuit board</i>.</p> <p><i>Before touching the circuit board touch an earth grounded metal surface such as the detector's power supply guard, a metal pipe or conduit to discharge any static electricity from your body, or wear an anti-static wrist strap connected to an earth ground.</i></p>
---	--

Calibration

To Set the Zero Point:

2. Ensure the sensor is warmed up and free from the target gas being measured either by purging the sensor with an inert gas, in ambient air free of the target gas or any interfering gases, or by blanking the sensor from the atmosphere with the calibration nose supplied and the caps in place.
3. Locate the blue millivolt test connector CN2 on the sensor transmitter circuit board.

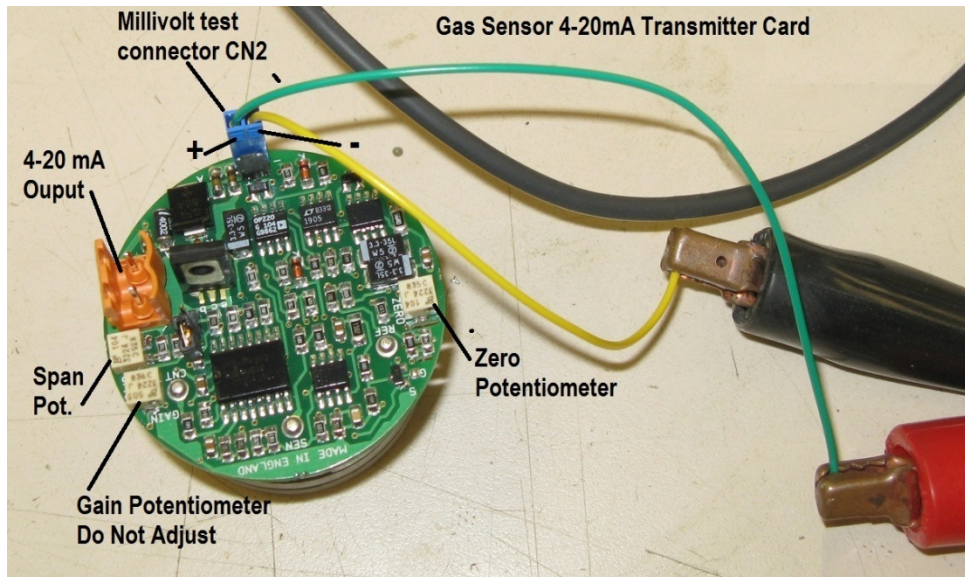

4. Plug the supplied test connector into the circuit board connector CN2. If you don't have the connector, insert wire leads into the millivolt connector, observe polarity when connecting your meter. If you only have a D.C. milliamp meter, disconnect the negative lead of the 4-20 millamp signal wire and connect the meter in series with the wiring loop (again, observe polarity when connecting the meter). Zero ppm always equals 4mA.
5. In ambient air, the zero reading should be 40 millivolts or 0.0 on the FX-15000 series display. If it's not, adjust the zero potentiometer with the jeweler's screwdriver until the correct reading is displayed.
6. The potentiometer is a multi-turn unit, and there is some signal dampening in the circuit, so the signal change may not fully stabilize until after you make the adjustment.
7. Do not adjust the span or gain potentiometers. Span calibration requires a gas standard calibration kit. The gain is factory set and should never be adjusted.

Calibration

Full Calibration, Toxic Gas Sensors

1. Make sure the zero point is set accurately, if not set the zero point as stated above.
2. Insert the calibration nose completely into the sensing chamber of the gas sensor, making sure the O-ring is seated properly to isolate the sensor from the atmosphere.
3. Remove the sealing caps from the calibration nose. One port on the calibration nose is used for gas inlet, **the other port must be left open as a vent**. Either port can serve as an inlet or vent.
4. Install the Teflon tubing connected to the 1 liter per minute feed rate gas regulator supplied with the calibration kit onto the calibration nose.

Warning: The gas regulator and tubing must be dedicated to one type of gas only, do not use a regulator and tubing for chlorine that was used on sulfur dioxide or ammonia, or vice versa.



5. Apply target calibration gas with a known concentration that matches the operating range of the sensor and detector and wait until the readings stabilize on the detector display. The reading will initially go down for several seconds before rising due to differences in humidity and pressure between the gas in the cylinder and the gas sensor.
6. Allow five minutes, sometimes slightly less, for the readings to stabilize.
7. Adjust the span potentiometer on the gas sensor until the correct reading is shown on the display.

You may also calibrate by using a millivolt meter:

8. Connect the meter leads, observing polarity, to millivolt test connector CN2.

Calibration

9. Apply the target gas to the sensor and allow the readings to stabilize as described above.
10. At full concentration the meter should display 200 mV, if not adjust with the span potentiometer.

Caution: Be sure to remove the calibration nose before placing the detector into service. Never operate the sensor with the calibration nose inserted.

Caution: If the sensor or detector will not allow you to fully adjust the displayed concentration to match that of the calibration gas then you must replace the gas sensor.

Calibration, Oxygen Sensors

Calibration should be carried out in ambient air, and is done simply by adjusting the span potentiometer until a reading of 20.9% on a scale of 0-25% is displayed on the LED display.

Calibration

Full Calibration, Ready Advanced Ammonia, Ozone, Hydrogen Cyanide Sensors

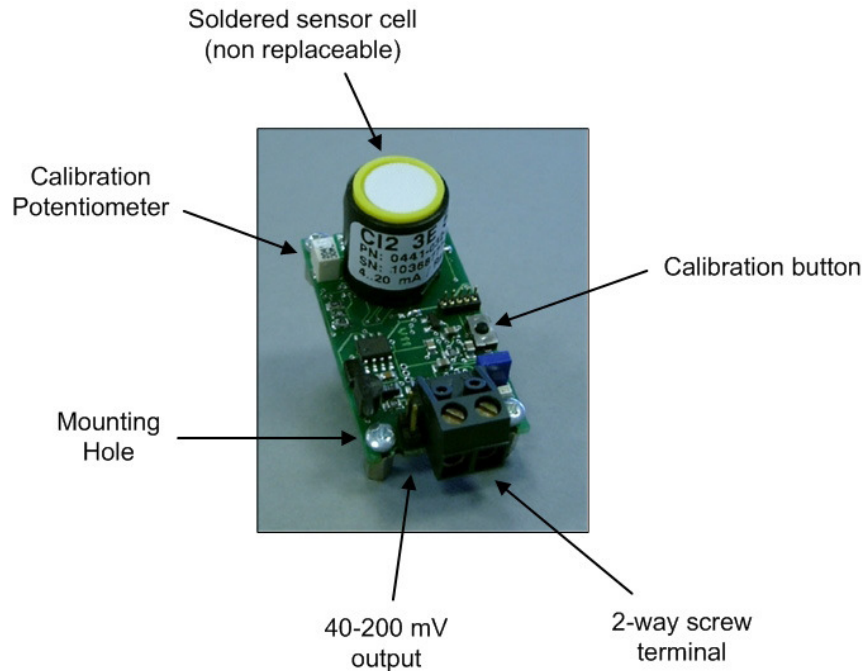

Zero Point Calibration

- Connect and apply power to the Gas Sensor Module.
- Allow the sensor to stabilize for a minimum of 5 minutes in clean air.
- Once the output signal is stable, press and hold the calibration button for between 6 and 12 seconds.
- The LED acknowledges calibration by blinking 6 times.

Span Calibration

Via calibration button

- Apply calibration gas to the sensor using the calibration nose at minimum 250ml/min flow rate for a minimum of 5 minutes.
- Once output signal is stable, press and hold the calibration button for between 12 and 60 seconds.
- The LED acknowledges calibration by blinking 8 times.
- Remove gas and reapply clean air.

Via potentiometer, calibrates the span only

- Apply calibration gas to the sensor at the appropriate flow rate for a minimum of 5 minutes.
- Once output signal is stable, set the output to the appropriate value by adjusting the potentiometer.
- Remove gas and reapply clean air.

Calibration

Factory Reset

- Press and hold the calibration button for between 3 and 6 seconds.
- The LED acknowledges the factory reset by blinking 4 times.

Sensor Response (Bump) Test

Important

The sensor response test, also known as a “bump” test, is only used to test the gas sensor’s ability to respond to a gas leak. This test is not a calibration. Sensor response, or bump tests should only be done with a known target concentration gas.

Note that the Industrial Safety Equipment Association (ISEA) defines a bump test as follows:

Functional (bump) test – A means of verifying calibration by using a known concentration of test gas to demonstrate that an instrument’s response to the test gas is within acceptable limits.

It is **very important** that this test sets off all the alarms and that the target concentration gas level is displayed on the LED display.

Full calibration is required if the test fails to set off alarms and the target concentration gas level is not displayed on the LED display.

1. The Remote alarm unit must be at zero on the LED display.
2. Install the calibration nose in the collar plug; be sure the nose is sealed properly and is isolated from the atmosphere.
3. Connect the target calibration gas sample tubing to the nose.
4. Apply target calibration gas with a known concentration, the sensor should begin to alarm within 20 seconds.
5. Wait for a stable reading to be obtained and compare it to the concentration on the calibration gas cylinder. The known target gas concentration level should be indicated on the LED display and all the alarms should be set off including the buzzer.
7. If the target calibration gas level is indicated on the LED display and the alarms are set off including the buzzer, test is complete.
8. Remove calibration nose, LED display should zero in a few minutes. Reset danger alarm.
9. If the target calibration gas level is not indicated on the LED display and or fails to set off all alarms a full calibration is required.

Gas Sensor Replacement

Electrochemical Cell Only

Sensor replacement in the FX-1500v4 Gas Detector is easily done with minimal tools.

Tools Required:

- Small Jeweler's Screwdriver
- Slotted or Phillips Screwdriver
- Needle nose Pliers

1. Disconnect the AC power from the detector.
2. Remove the sensor enclosure from the wall.
3. Remove the front cover of the sensor enclosure.
4. Carefully pull off the orange wire connector.
5. Flip the enclosure so that you can see the bulk head nut (see page 33 for diagram). Place the tips of a pair of needle nose pliers in the two holes of the sensor bulk head nut. Turn the ring counterclockwise to loosen the ring, and remove the entire sensor from the enclosure.
6. The transmitter PC board is mounted to the sensor with disconnect pins. Hold the PC board by the edges and carefully pull the board off of the sensor.
7. Remove and discard the 3 mounting screws. They are metric. The new sensor will come with 3 new #2-56 screws that match the thread inserts in the new sensor. Keep the collar, membrane, and o-rings. They will be used to mount the new sensor.
8. Install the collar, membrane, and o-rings on the new sensor, using the screws that came with the new sensor.
9. Remove the shorting wire from the gold pins on the new sensor, and carefully line up the 3 gold pins on the new sensor with the (3) sockets on the bottom of the transmitter board. Press evenly on the board until it fully seats on the gold pins.
10. Installation of the completed sensor/transmitter assembly is the reverse of its removal.
11. After completing the sensor replacement procedure, power-up the gas detector and allow it to stabilize for twenty minutes or so (some sensor gas types take up to 24 hours to stabilize). The display should show 0.0 ppm +/-0.1 ppm. If the display is off by more than 0.2 ppm, or the cell failure/problem light is blinking, the sensor requires a full sensor calibration.
12. Perform a full calibration, including the zero point calibration.

Gas Sensor Replacement

Sensor with 4-20mA Transmitter Board

Tools Required:

- Slotted or Phillips Screwdriver
- Needle nose Pliers
 1. Disconnect the AC power from the detector.
 2. Remove the sensor enclosure from the wall.
 3. Remove the front cover of the sensor enclosure.
 4. Carefully pull off the orange wire connector.
 5. Flip the enclosure so that you can see the bulk head nut. Place the tips of a pair of needle nose pliers in the two holes of the sensor bulk head nut. Turn the ring counterclockwise to loosen the ring, and remove the entire sensor from the enclosure.
 6. Reverse this procedure to install the new sensor with transmitter board.
 7. After a sufficient warm up period check the zero point of the sensor and adjust if needed.
 8. Conduct the sensor response test. If the sensor fails this test a full calibration is required.

Gas Sensor Components

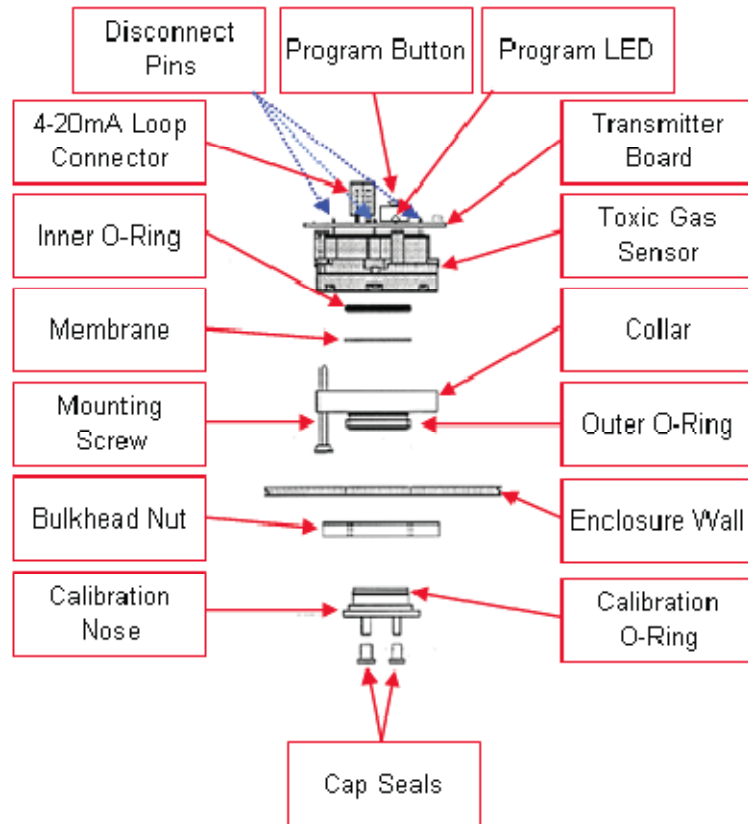

Gas Sensor Replacement

Ready Advanced Ammonia Sensor with 4-20mA Transmitter Board

CAUTION: This component is susceptible to Electrostatic Discharge (ESD) when being installed or adjusted.

1. Disconnect the AC power from the detector.
2. Remove the sensor enclosure from the wall.
3. Remove the front cover of the sensor enclosure.
4. Discharge static electricity from your body and tools by touching a metal part of the equipment or use a ground strap connected to an earth ground.
5. Pull off the two power connectors. Note the sensor module offers reverse polarity protection, so the power supply can be connected in either direction.
6. Remove the mounting screws.
7. Reverse this procedure to install the new sensor.
8. After a sufficient warm up period check the zero point of the sensor and adjust if needed.
9. Conduct the sensor response test. If the sensor fails this test a full calibration is required.