

SWARCO

# McCain HAWK TRAFFIC SIGNAL

HIGH-INTENSITY ACTIVATED CROSSWALK BEACON

12" DIAMETER  
ALUMINUM  
POLYCARBONATE



The McCain HAWK Traffic Signal quickly alerts drivers to pedestrian presence at a mid-block pedestrian crossing by demonstrating a flashing-amber to stationary-red sequence. Pedestrian activated HAWK signals only stop traffic as needed allowing for longer periods of uninterrupted traffic flow. The housings are compliant with multiple agency standards and most state Departments of Transportation. SWARCO McCain, Inc. offers these signal assemblies with a wide range of mounting options and accessories, including backplates and visors to meet your traffic signal requirements.



Black without backplate

## KEY FEATURES AND BENEFITS

- Increases pedestrian safety
- Alerts drivers to pedestrian presence
- Creates safer mid-block pedestrian crossings without the need for a traditional intersection
- Protects components from the elements

## PRODUCT DESCRIPTION

The housing of the McCain HAWK Traffic Signal is fabricated from either one-piece aluminum or polycarbonate and mounted in a three-section HAWK configuration. Reinforcement ribs and serrated ports, both top and bottom of each housing, provide strength and positive locking with other sections and mounting hardware.

Positive latching of doors is achieved with stainless steel eyebolts and wing nut assemblies, and the doors feature four metal threaded inserts for visor attachment. A positive seal is assured with an EPDM rubber gasket, creating a moisture-free and dust-tight atmosphere. Hardware and terminal block location are customizable.

# McCain HAWK TRAFFIC SIGNALS

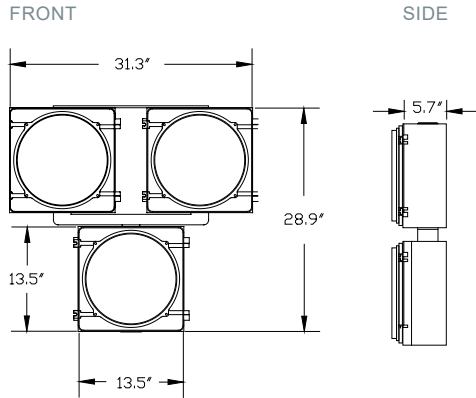

BOTTOM

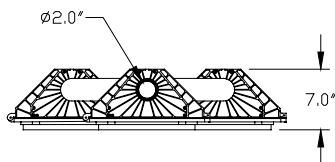

SQUARE BACKPLATE, LOUVERED, 5" BORDER

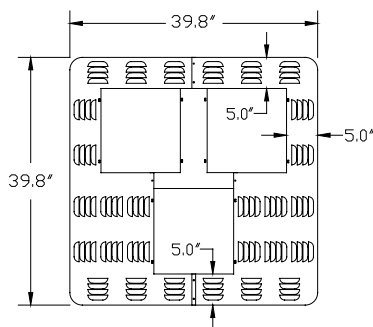

CONTOURED BACKPLATE, LOUVERED, 5" BORDER

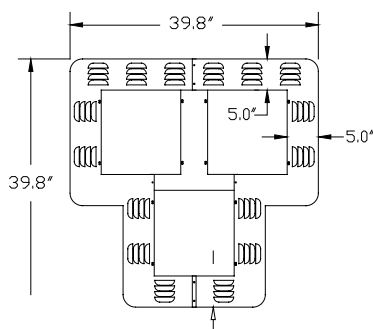

## STANDARD FEATURES

- One-piece, injection molded or cast
- 72-tooth serrated boss and reinforcing ribs, top and bottom
- Brass threaded inserts for visor attachment (4)
- Housings have a cast boss for mounting a 5 or 6-position terminal block<sup>1</sup>
- Words red, amber, and green are cast next to each boss to identify light source lead wires
- 5 or 6-position terminal block installed in center section<sup>2</sup>
- Stainless steel door roll pins and eye bolt/wing nut assemblies
- Integral lugs on the housing and doors with stainless steel roll pins provide effective door hinges
- Weathertight EPDM rubber door gasket

## GENERAL SPECIFICATIONS

Dimensions <sup>3</sup> :	31.3"W x 28.9"H x 7"D
Material:	Aluminum: Type 360, reduced corrosion, increased powder coat adhesion Polycarbonate: Ultraviolet and heat stabilized, flame retardant, permanently colored, 10% fiberglass reinforcement
Finishes:	Aluminum: Powder coated Polycarbonate: Colored resins integral to housing
Colors:	Federal yellow, signal green, black, or custom colors
Light Source:	LED or incandescent
Mounting:	2.0" hole top and bottom fits 1.5" NPT fittings
Environmental:	Operating temperature: -37°C to +74°C Humidity: 0 to 95% (non-condensing)
Shipping Weight <sup>4</sup> :	Aluminum: 23 lbs Polycarbonate: 13 lbs

## OPTIONS

- Fiberglass-free polycarbonate
- Aluminum and polycarbonate housings can be mixed in one signal head
- Location, quantity, and type of terminal blocks
- Door hardware: permanent or removable<sup>5</sup>
- Visors
- Mounting: Various framework including plumbizer
- Backplates<sup>6</sup>: louvered, non-louvered, 5" or 8" border, contoured or squared shape, reflective tape, flanged

<sup>1</sup>One side of terminal block with fast-on terminals, the other side with screw terminals

<sup>2</sup>Alternate mounting is available

<sup>3</sup>Dimensions rounded to the nearest 0.1" without backplate

<sup>4</sup>Empty with out components

<sup>5</sup>Permanent with roll pins or removable with clevis pins

<sup>6</sup>Sold separately