

S-5-E Mini Flange

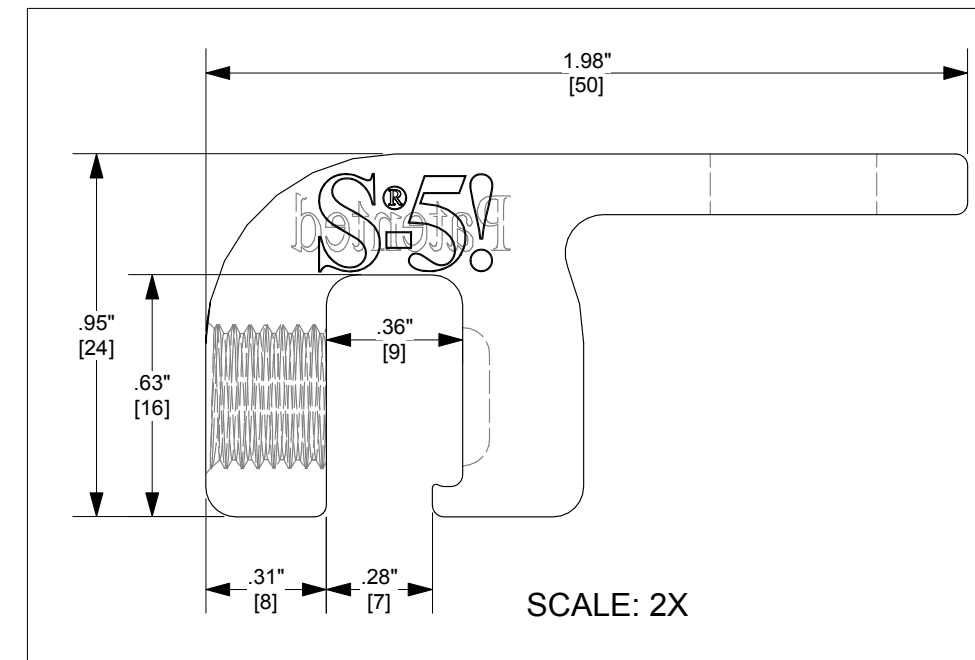

ELONGATED THRU HOLE

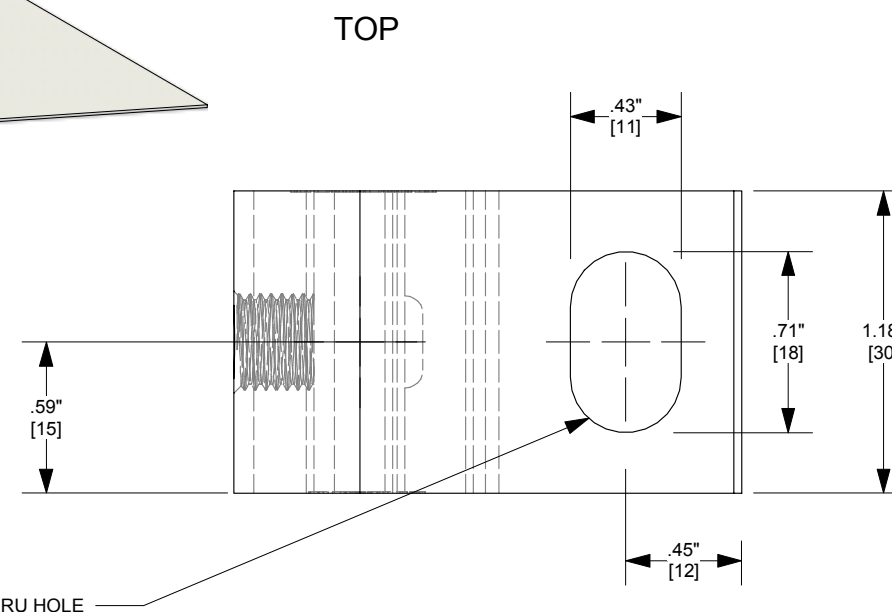
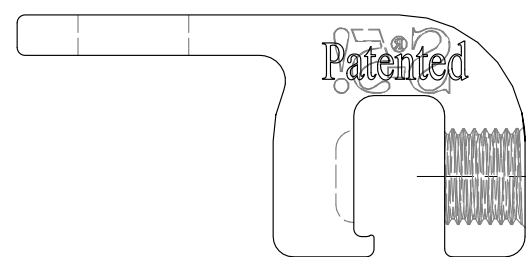

BACK

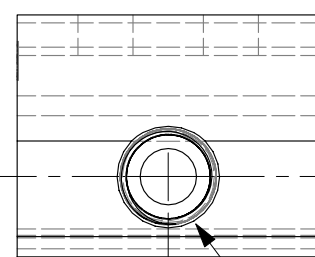

LEFT

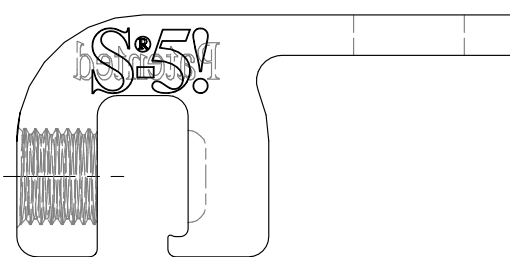

FRONT

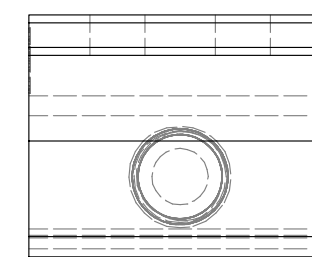

RIGHT

3/8-24 THREADED HOLE

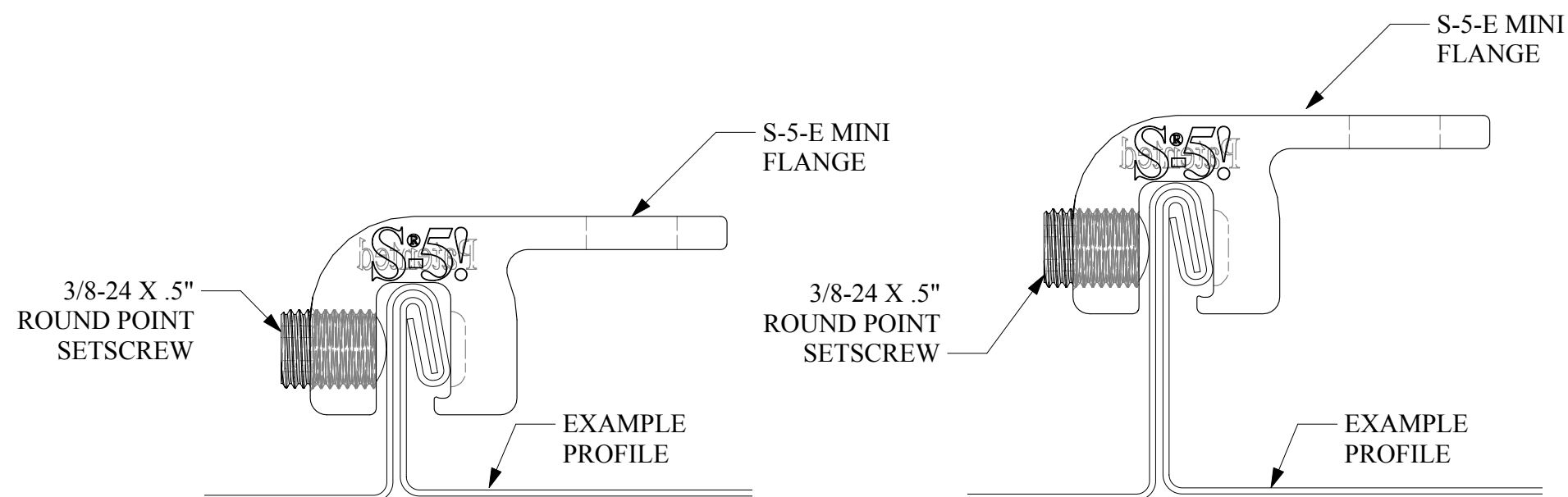

FOR STANDING SEAM SPECIFIC MECHANICAL LOAD TEST INFORMATION AND CLAMP INSTALLATION INFORMATION PLEASE VISIT: WWW.S-5.COM

MATERIAL: 6061 T6	 The Right Way!	METAL ROOF INNOVATIONS, LTD. 8655 TABLE BUTTE RD COLORADO SPRINGS, CO 80908 719-495-0518 719-495-0045 (FAX)	
EST ASSEMBLY WEIGHT : 0.94 LBS		TITLE S-5-E MINI Flange	
SUPPLIED HARDWARE: 3/8-24 X .5" 18-8 SS	DRAWING NO. EFL04-A-1-A CCD	DRAWN BY DMMH	DATE 11/15/2012
SCALE: 1:0.75	<small>S-5!® PRODUCTS ARE PROTECTED BY MULTIPLE U.S. PATENTS INCLUDING 5,228,248, 5,983,588 AND 6,164,033 (OTHERS ISSUED AND PENDING). EUROPEAN PATENTS ARE ALSO APPLIED FOR AND PENDING UNDER THE PATENT COOPERATION TREATY WITH DIVISIONAL FILING RIGHTS RETAINED. METAL ROOF INNOVATIONS, LTD. (LICENSOR OF S-5!® TECHNOLOGY) AGGRESSIVELY PROSECUTES PATENT INFRINGEMENT.</small>		
OTHER:			