

MOBIUS M9 AUTOFEED CONVEYOR



USER GUIDE



CONTENTS

SAFETY **4**

SAFETY INSTRUCTIONS	5
DISCLAIMER	5
WARNING LABELS	6
SERVICE & REPAIRS	6
GENERAL SAFETY PRECAUTIONS	7

INITIAL SETUP **8**

GET TO KNOW YOUR CONVEYORS	9
WHAT'S IN THE CRATE	10
INITIAL ASSEMBLY & INSPECTION	11

OPERATIONS **18**

GENERAL OPERATION	19
BEARING REPLACEMENTS	21

CLEANING & MAINTENANCE **27**

CLEANING THE CONVEYORS	28
PREVENTATIVE MAINTENANCE	28
SPECIFICATIONS	29

NOTES:

This User Guide is a comprehensive manual covering the operation and maintenance of the Infeed and Outfeed Conveyor machines as of the date of publication. ETEROS TECHNOLOGIES reserves the right to make updates to the machine from time to time. In the event of an update, this User Guide will remain appropriate for the safe operation and maintenance of your unit. This User Guide, as well as any documentation supplied by component manufacturers, are to be considered the information package associated with this device. Every operator must read and understand the User Guide. The manual should be located within easy access for periodic review.

SAFETY

SAFETY INSTRUCTIONS

To ensure operator safety while in use, this device includes decaling, guarding, and other safety features. Operators are encouraged to use caution and best judgment when using equipment. Equipment should be serviced when required.

To avoid possible damage to the machine and risk of injury to the operator, consult with an ETEROS TECHNOLOGIES representative to answer any questions.

All operators must read and understand this User Guide and be trained in safe operation and use of the M9 Autofeed Conveyor. We recommend the owner of this equipment develop a standard operating procedure specific to each worksite to address any local hazards or other conditions not outlined in this User Guide. The conveyor must be inspected regularly for damage, component failure and wear. Results of inspection activity should be documented.

ETEROS TECHNOLOGIES makes every effort to ensure the M9 Autofeed is compliant with all current safety standards. It is the responsibility of the owner to ensure all municipal, provincial, state, county, territorial, and federal codes, regulations and standards have been met in each working location.

Do not lend or rent your machine without providing the User Guide. A first-time operator should receive practical instruction before using the machine.

This machine is not to be used for any purpose other than those expressly stated in the User Guide, advertising literature, or other ETEROS TECHNOLOGIES written material pertaining to the conveyors.

DISCLAIMER

ETEROS TECHNOLOGIES recognizes that the Infeed and Outfeed Conveyors are purpose-built machines for processing cannabis by licensed producers. Please check all municipal, provincial/state, and federal laws and regulations before using the Infeed and Outfeed Conveyors. ETEROS TECHNOLOGIES does not promote or condone the use of processing equipment in any way that may be deemed illegal.

ETEROS TECHNOLOGIES recognizes that our equipment can be used for processing herbs, hops, flowers and many other products. It is not the responsibility of ETEROS TECHNOLOGIES to confirm alternative applications for our equipment.

WARNING LABELS



DANGER:

Indicates a hazardous situation that, if not avoided, will result in serious injury and / or death. This signal word is to be limited to the most extreme situations; typically for machine components that, for functional purposes, cannot be guarded.



WARNING:

Indicates a potentially hazardous situation that, if not avoided, could result in serious injury and / or death. It includes hazards that are exposed when guards are removed. It may also be used to alert against unsafe practices.



CAUTION:

Indicates a potentially hazardous situation that, if not avoided, may result in minor or moderate injury. It may also be used to alert against unsafe practices.

SERVICE & REPAIRS

Repairs may only be carried out by Eteros Technologies or a designated authorized agent (service technician).

Should the need arise, please notify us:

ETEROS TECHNOLOGIES
26 Industrial Ave.
Carleton Place, Ontario, Canada
K7C 3T2
www.eteros.com

Improper interfacing, improper repair, or unauthorized modification could result in void warranty claims.

GENERAL SAFETY PRECAUTIONS

1. READ and become familiar with the entire User Guide. LEARN the equipment applications, limitations, and possible hazards.
2. DO NOT USE THE DEVICE IN A DANGEROUS ENVIRONMENT or damp or wet locations. Never expose the control panel directly to rain or water. Keep the work area well illuminated.
3. DO NOT use the device in the presence of flammable liquids or gases.
4. KEEP WORK AREA CLEAN. Cluttered areas and workspaces invite accidents.
5. WEAR PROPER APPAREL. Do not wear loose clothing, gloves, neckties, rings, bracelets, or other jewelry which may get caught in moving parts. Non-slip footwear is recommended. Wear protective hair covering to contain long hair.
6. POWER DOWN AND DISCONNECT EQUIPMENT before washing, servicing and when changing accessories.
7. CHECK FOR DAMAGED PARTS PRIOR TO OPERATION. The equipment should be inspected prior to use to ensure proper operation in performing its intended function. Check for alignment of moving parts, binding of moving parts, breakage of parts, mounting, and any other conditions that may affect its operation. Any damaged part including guards should be properly repaired or replaced.
8. ALWAYS WEAR EYE PROTECTION.

INITIAL SETUP

GET TO KNOW YOUR CONVEYORS

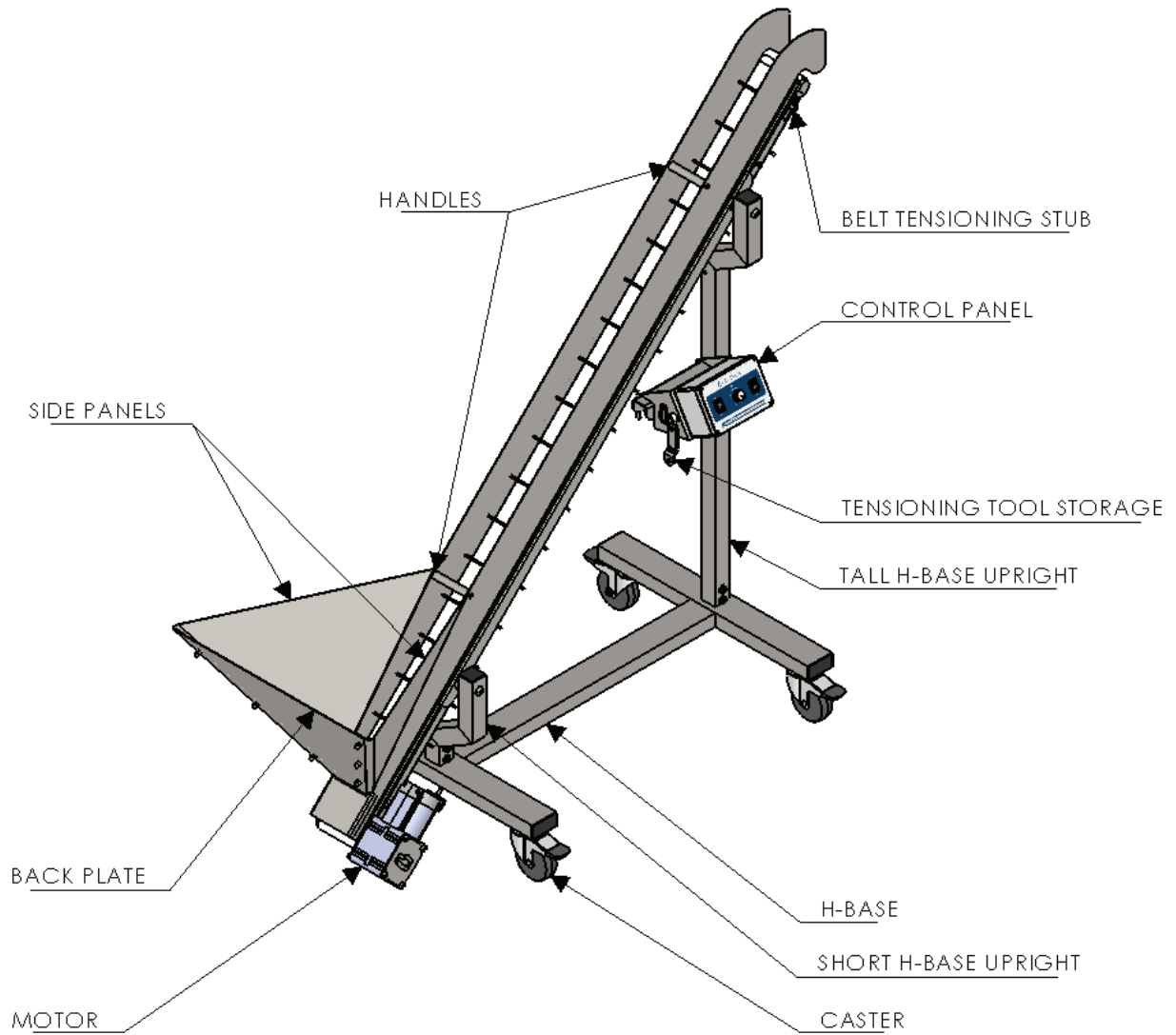

WHAT'S IN THE CRATE

YOUR AUTOFEED CONVEYOR COMES WITH THE FOLLOWING ITEMS:

- 1 x H-BASE
- 1 x TALL H-BASE
- 1 x SHORT H-BASE
- 2 x THROUGH STOPS
- 1 x CONTROL PANEL WITH TOOL STORAGE
- 4 x 2" HEX BOLTS
- 4 x NUTS
- 4 x WASHERS FOR HEX BOLTS
- 2 x 1" BUTTON HEAD SCREWS
- 6 x 3/8" BUTTON HEAD SCREWS
- 4 x 5/8" BUTTON HEAD SCREWS
- 2 x SIDE PANELS
- 2 x HOPPER HANDLES
- 6 x ACORN NUTS
- 1 x TENSIONING TOOL
- 2 x SUPPORT BAR

INITIAL ASSEMBLY & INSPECTION

1. Inspect the crate and crate contents to ensure no damage occurred during shipping.
2. Remove components from the crate.
3. Begin by installing the SHORT H-BASE UPRIGHT to the H-BASE by using 2 x 2" HEX BOLTS, 2 x WASHERS and 2 x NUTS. The head of the bolts should sit within The head of the bolts should sit within The head of the bolts should sit within the hexagonal cutouts on the H-BASE UPRIGHTS. Ensure that both pieces are installed facing the same direction.

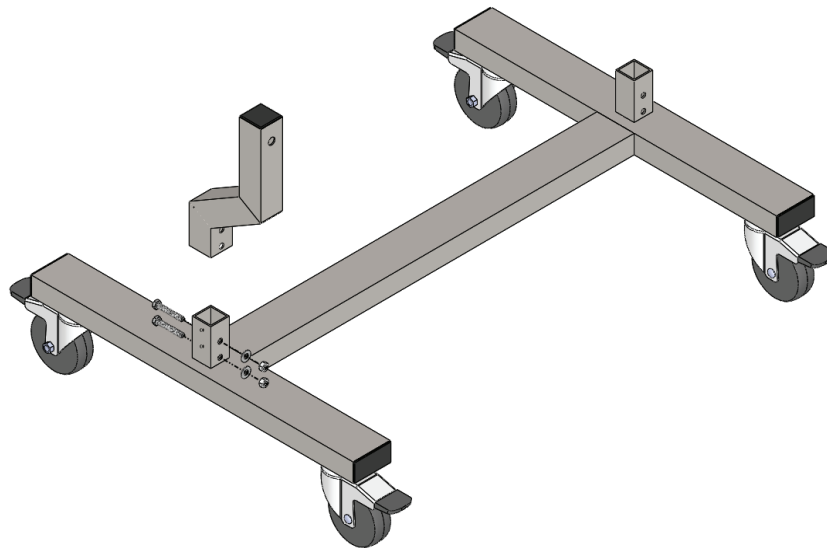

4. Install the TALL H-BASE UPRIGHT to the H-BASE using the same hardware in the last step.

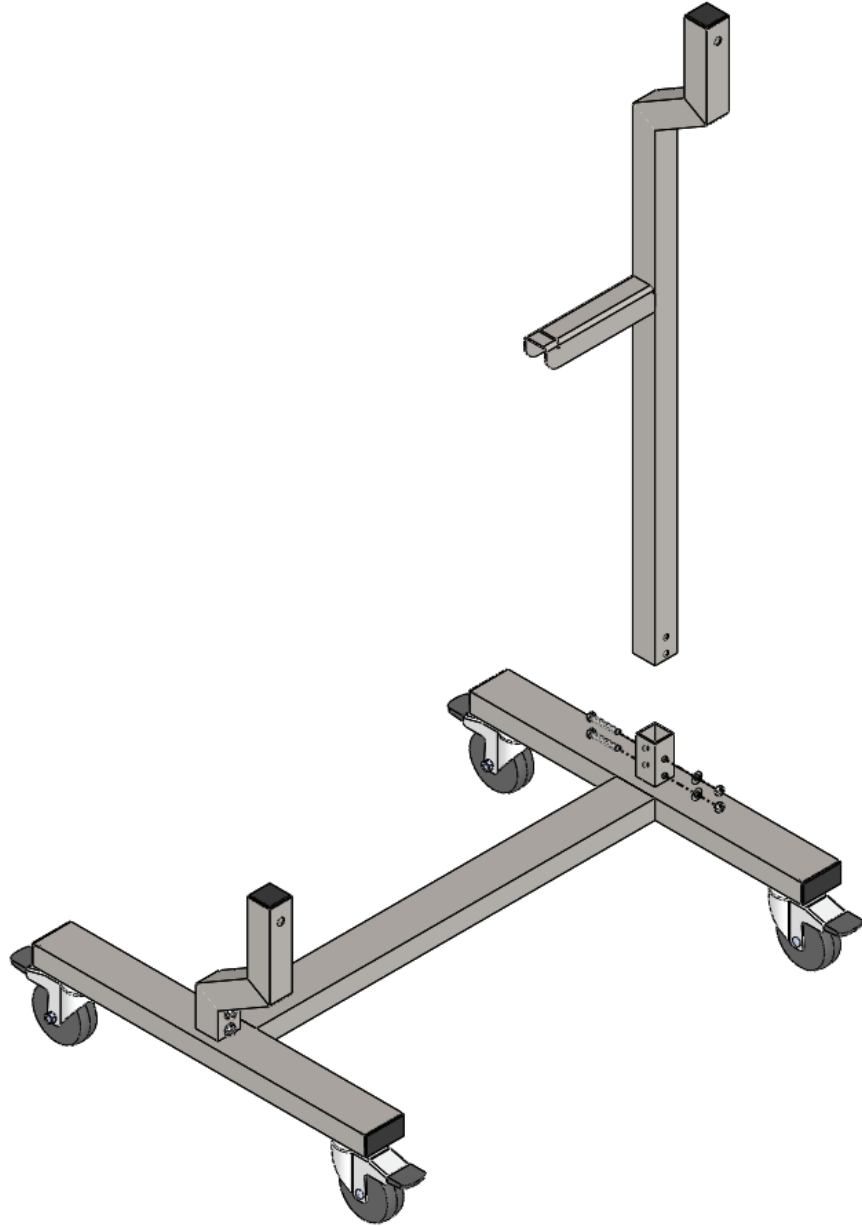

- Slide 2 x THROUGH SUPPORT BARS through the conveyor body. Then, slide 2 x THROUGH STOPS on to the protruding ends of the THROUGH SUPPORT BARS. Ensure the lip on the THROUGH STOPS is flush with the sheet metal. With the THROUGH STOPS installed, and with the help of another person, slide the protruding bars into the SHORT H-BASE UPRIGHT and TALL H-BASE UPRIGHT and fasten with 2 x 1" BUTTON HEAD SCREWS.

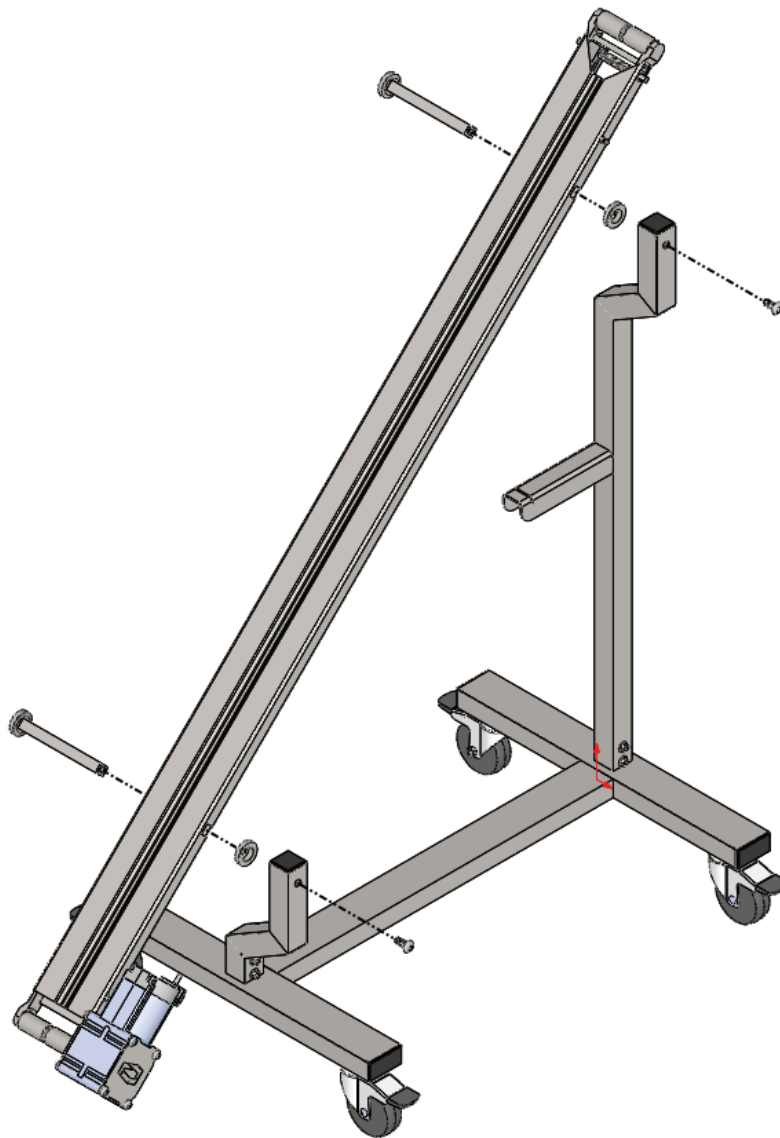

6. Install the BELT onto the conveyor body by simply sliding it on to each end. Ensure the groove along the underside of the BELT is aligned in the grooves on the rollers at each end of the conveyor. Operation section. The CONTROL PANEL can also be placed on the mounting bar as shown.

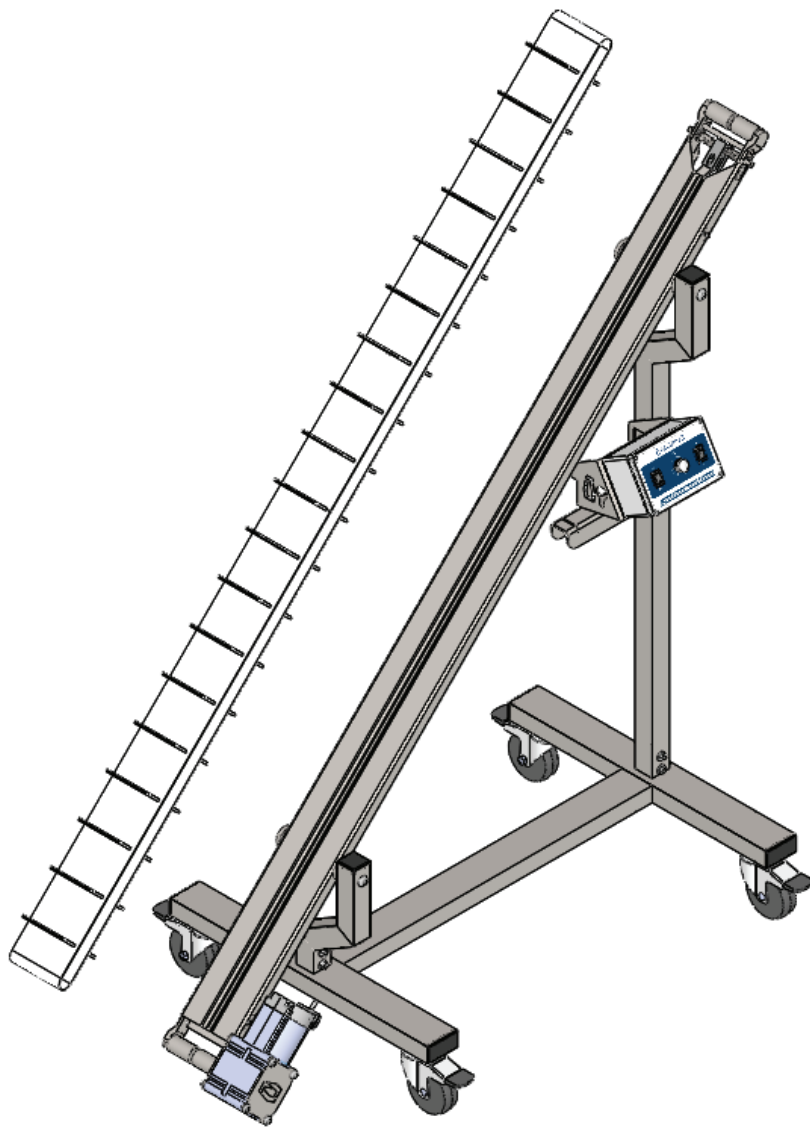

7. Install a SIDE PANEL on each side of the conveyor by aligning the circular cutouts with the THROUGH STOPS and THROUGH BARS. Simply slide each panel down onto the pucks to install it on the conveyor.

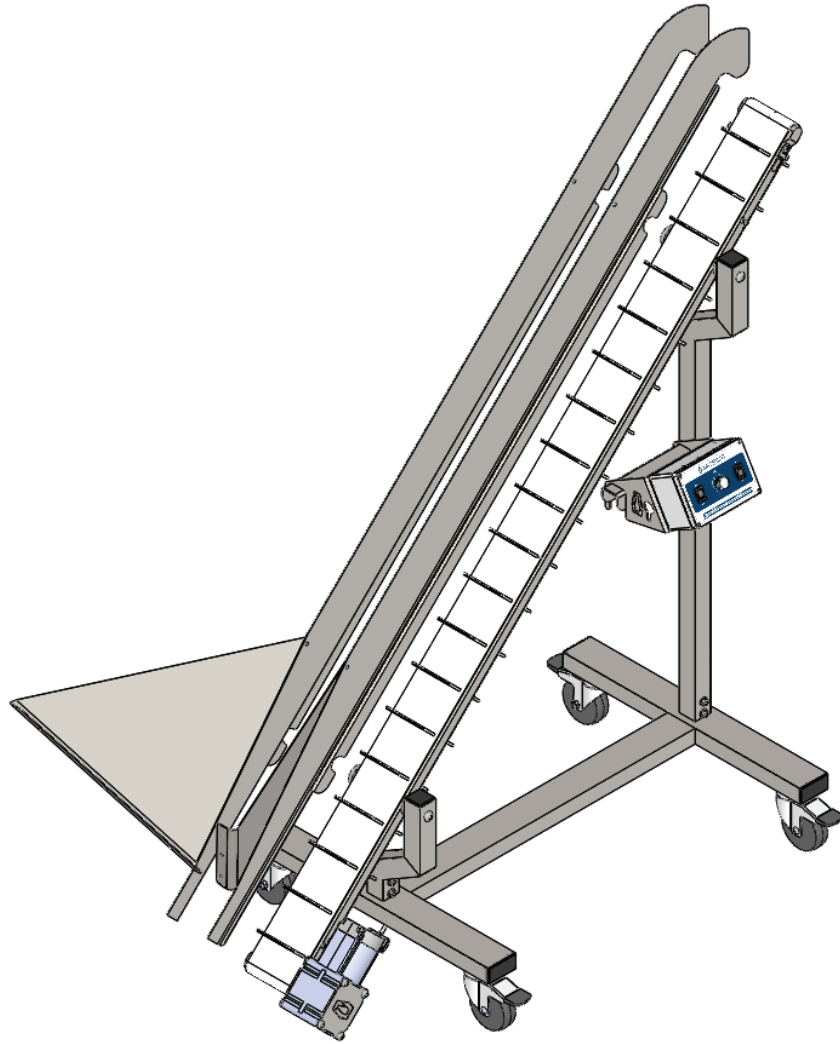

- Join the side panels to each other by installing the HOPPER HANDLES. Align a handle with the screw hole cutouts on the side panels, and secure using 2 x 5/8" BUTTON HEAD SCREWS.

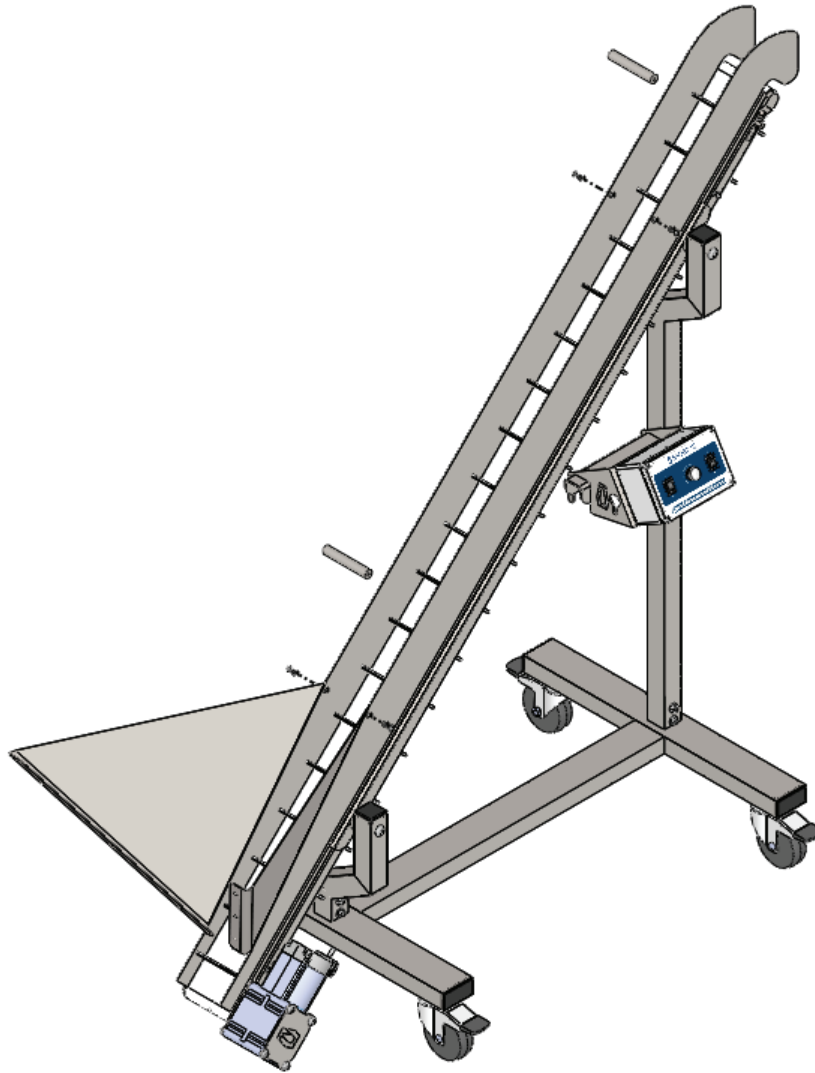

9. Finally, to complete the hopper assembly, install the BACK PLATE on to the outside of the side panels by aligning the screw holes and securing with 6 x 3/8" BUTTON HEAD SCREWS. The screw heads should go on the inside of the hopper, and the 6 x ACORN NUTS can be used on the outside to firmly secure the BACK PLATE.

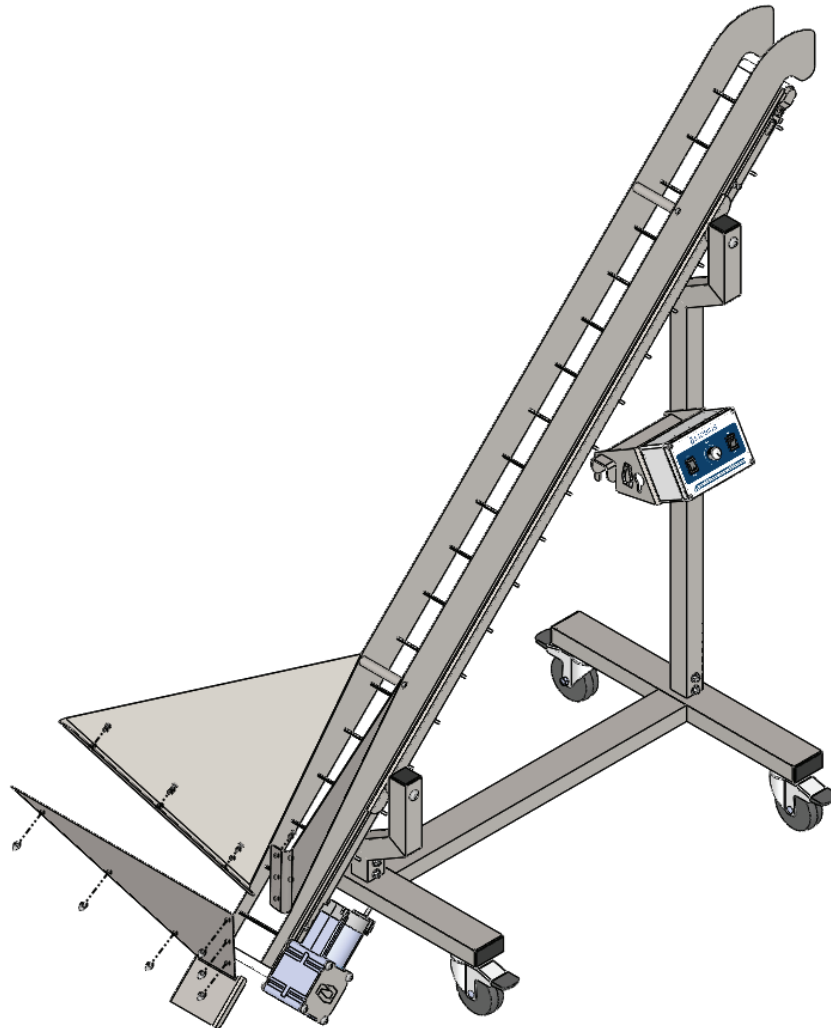

10. Using the TENSIONING TOOL, turn the BELT TENSIONING STUB to ensure that the belt is properly tensioned. DO NOT OVER TORQUE THE BELT TENSIONING STUB, PERMANENT DAMAGE MAY RESULT. The TENSIONING TOOL can be stored in the keyhole cutout on the CONTROL BOX.

11. Once initial assembly is complete, inspect the conveyors to confirm that they are ready to operate:

- Confirm the power cord is in good condition
- Ensure the belt is properly aligned on the rollers on each end
- Ensure the belt is properly tensioned
- Ensure all fasteners are tight and that there is no wobble in the frame

OPERATIONS

GENERAL OPERATIONS

REMOVING AND INSTALLING CONVEYOR BELT

To remove the belt:

1. Grab the handles on the HOPPER, and lift it off the conveyor.
2. While standing on the opposite side of the motor, use the TENSIONING TOOL to turn the BELT TENSIONING STUB clockwise until significant resistance is felt. DO NOT KEEP TURNING PAST THIS POINT.
3. Once there is enough slack in the belt, simply slide it off the side of the conveyor.

To re-install the belt:

1. Slide the conveyor belt on to the metal body from the side of the machine.
2. Ensure the groove on the underside of the belt is positioned in the slots of the rollers at each end. You'll feel the belt "click" into place once positioned correctly.
3. Using the TENSIONING TOOL, turn the BELT TENSIONING STUB counterclockwise until the belt is tensioned. When the belt is adequately tensioned, the BELT TENSIONING STUB will provide significant resistance against further turning. DO NOT TENSION THE BELT PAST THIS POINT. DO NOT USE A POWER TOOL TO TENSION THE BELT. PERMANENT DAMAGE WILL RESULT.

CONTROL PANEL ADJUSTMENT

For ease of use with other Mobius equipment, the orientation of the control panel can be reversed so that it can be accessed from either side of the equipment. To switch the control panel:

1. Lift the CONTROL BOX off the CONTROL BOX MOUNTING BAR. No tools or fastener removal is required.
2. Rotate the CONTROL BOX so that it is facing the other side of the equipment, and place it down on the CONTROL BOX MOUNTING BAR.

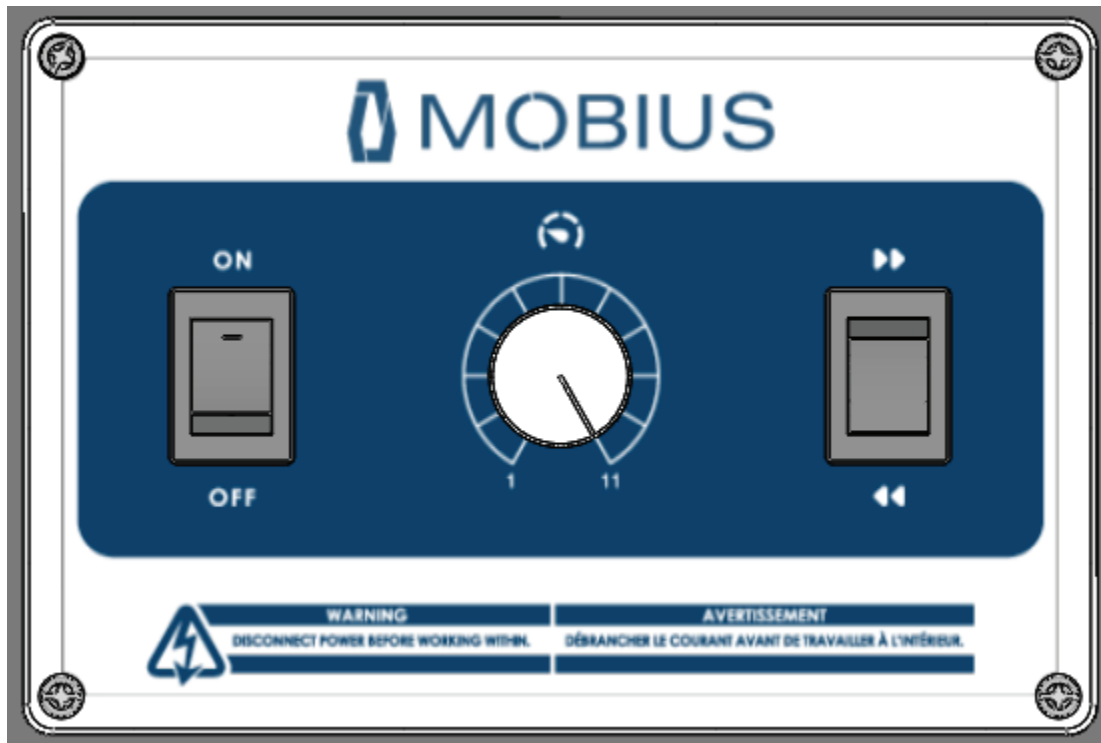

LEFT = ON/OFF: turns the conveyor on or off. In the on position, the conveyor will immediately begin running at the set speed and direction. In the off position, no power is delivered to the machine.

MIDDLE = SPEED CONTROL: rotate the knob clockwise to increase the belt speed, and rotate the knob counterclockwise to reduce belt speed.

RIGHT = DIRECTION CONTROL: flipping the direction switch will change the travel direction of the belt

MACHINE START UP SEQUENCE

1. Plug the power cord into an outlet.
2. Ensure belt is tensioned.
3. Ensure hopper is installed.
4. Flip the power switch to the ON position.
5. Flip the direction switch to set the conveyor to the correct travel direction.
6. Turn the speed adjustment knob clockwise to increase the belt speed, or counterclockwise to reduce the belt speed.

BEARING REPLACEMENT

Should the need arise to replace the bearings in your M9 Autofeed Conveyor, the process is straightforward and involves little more than removing some screws. Follow along with the steps below and you'll have your conveyor back up and running in no time!

TO REPLACE BEARINGS ON THE TENSIONING SIDE OF YOUR AUTOFEED CONVEYOR

1. Start by removing the side panels.
2. Use the conveyor tensioning tool to remove tension from the belt, then slide the belt off and set aside.
3. Using a 9/64 Allen key, undo the two screws that secure the tensioning assembly to the body of the conveyor.

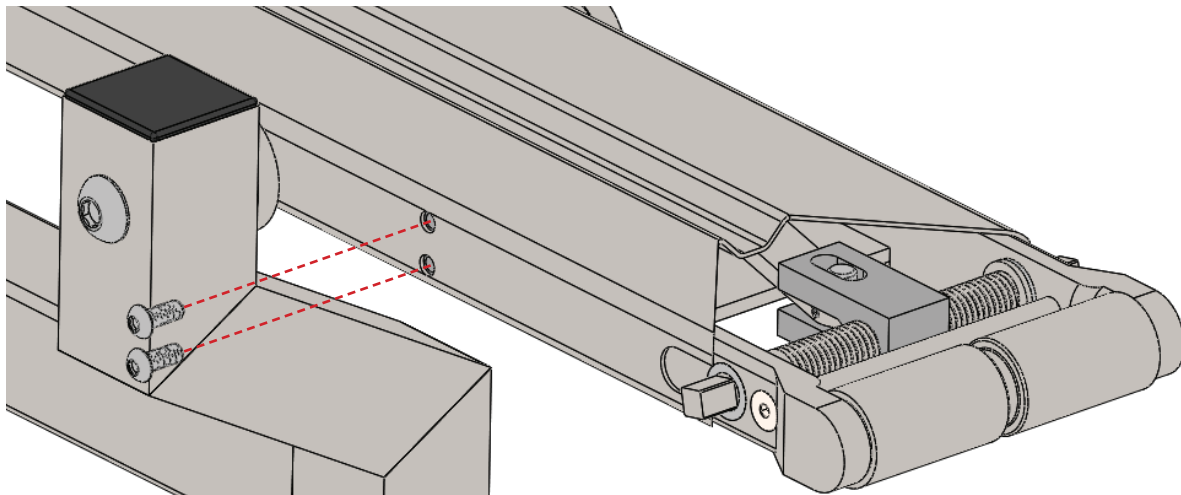

4. With the screws removed, grab onto the roller and slide the tensioning assembly right out of the conveyor.
5. Set the tensioning assembly upside down on a table or workbench.

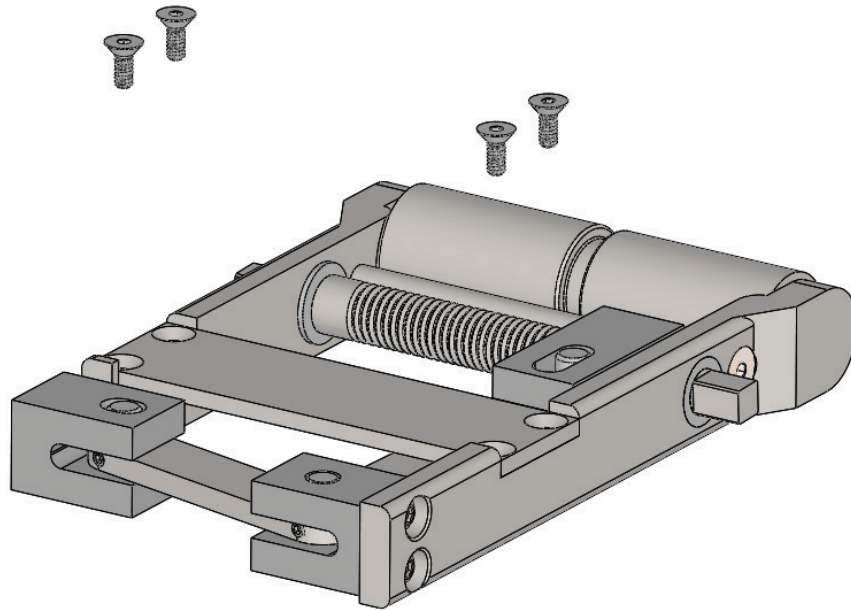

6. Using a 5/32 hex key, remove the 4 screws securing the plate to the two side arms.

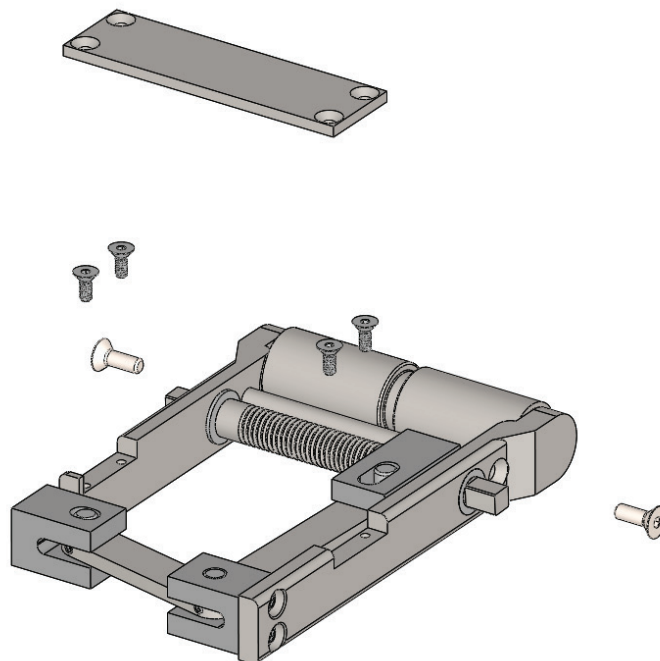

7. Using a 9/64 hex key, remove the flathead screw from the round bar that spans across the tensioning assembly on the side with the problematic bearing.

8. With the plate removed, separate the side arm with the problematic bearing. Remove the bearing, and install your new bearing in the bore. Then, reinstall the plate you removed in the previous step. NOTE: if the problematic bearing is in the arm on the right (pictured below), there are two additional screws that need to be removed.

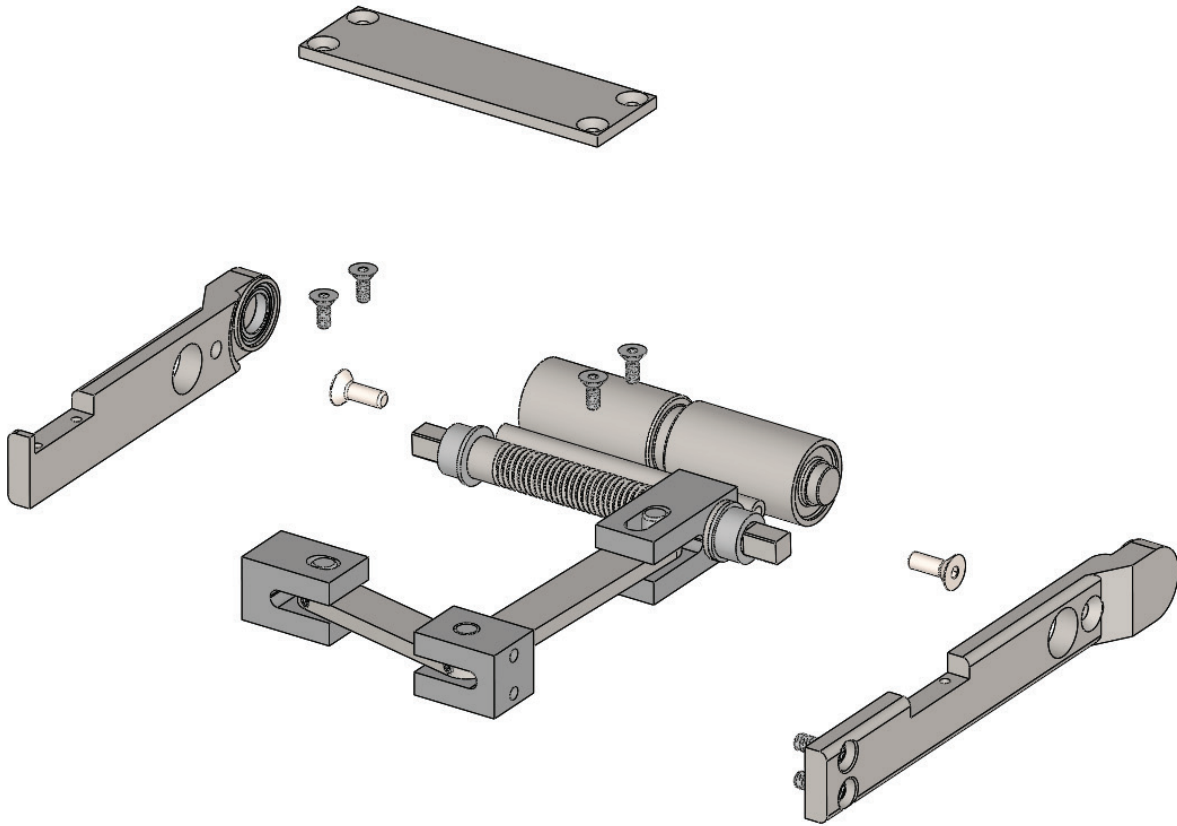

9. Slide the tensioning assembly back into the conveyor body, and secure it with the 2 screws that were removed earlier.

10. Reinstall the belt and side panels.

TO REPLACE BEARINGS ON THE MOTOR SIDE OF YOUR AUTOFEED CONVEYOR

1. Remove the side panels and belt as per steps 1 and 2 of the previous section.
2. Remove the 4 bolts securing the motor to the conveyor using a 6mm hex key, then slide the entire motor off the drive shaft and set aside.

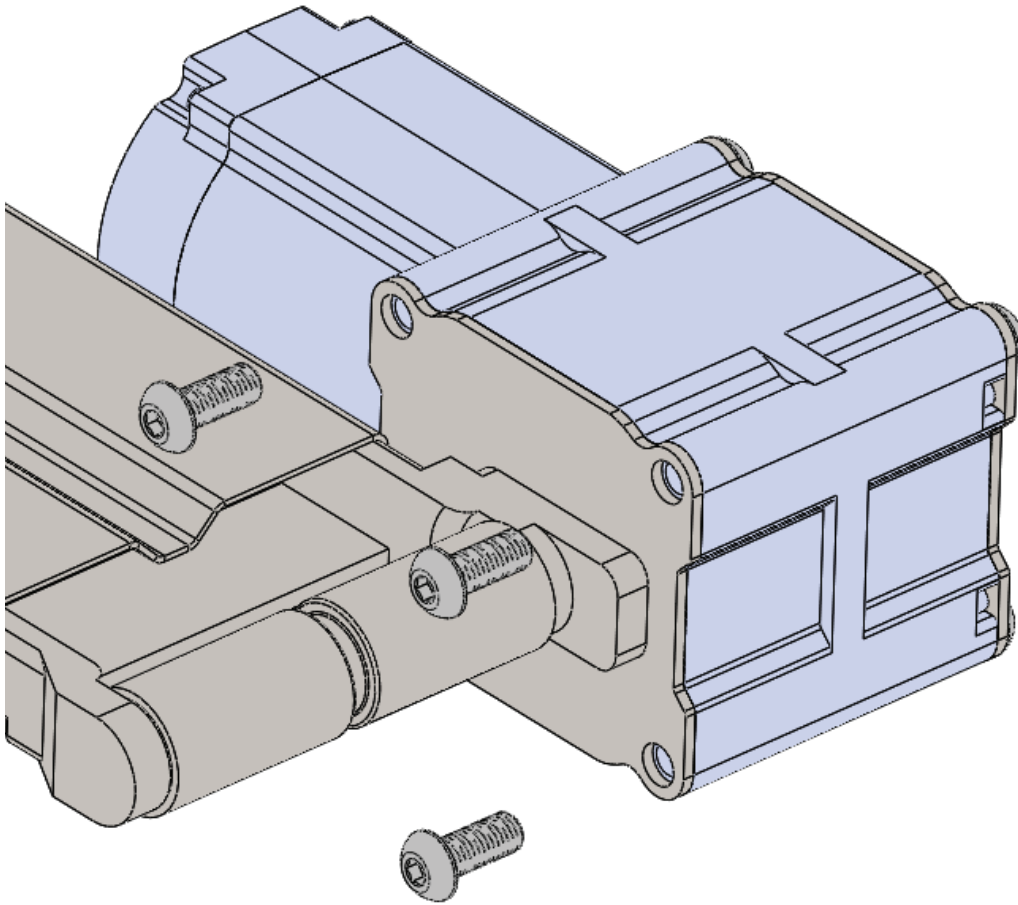

- Using a 9/64 hex key, remove the 4 bolts securing the motor assembly to the conveyor body. Remove the motor and set these aside in a safe place.

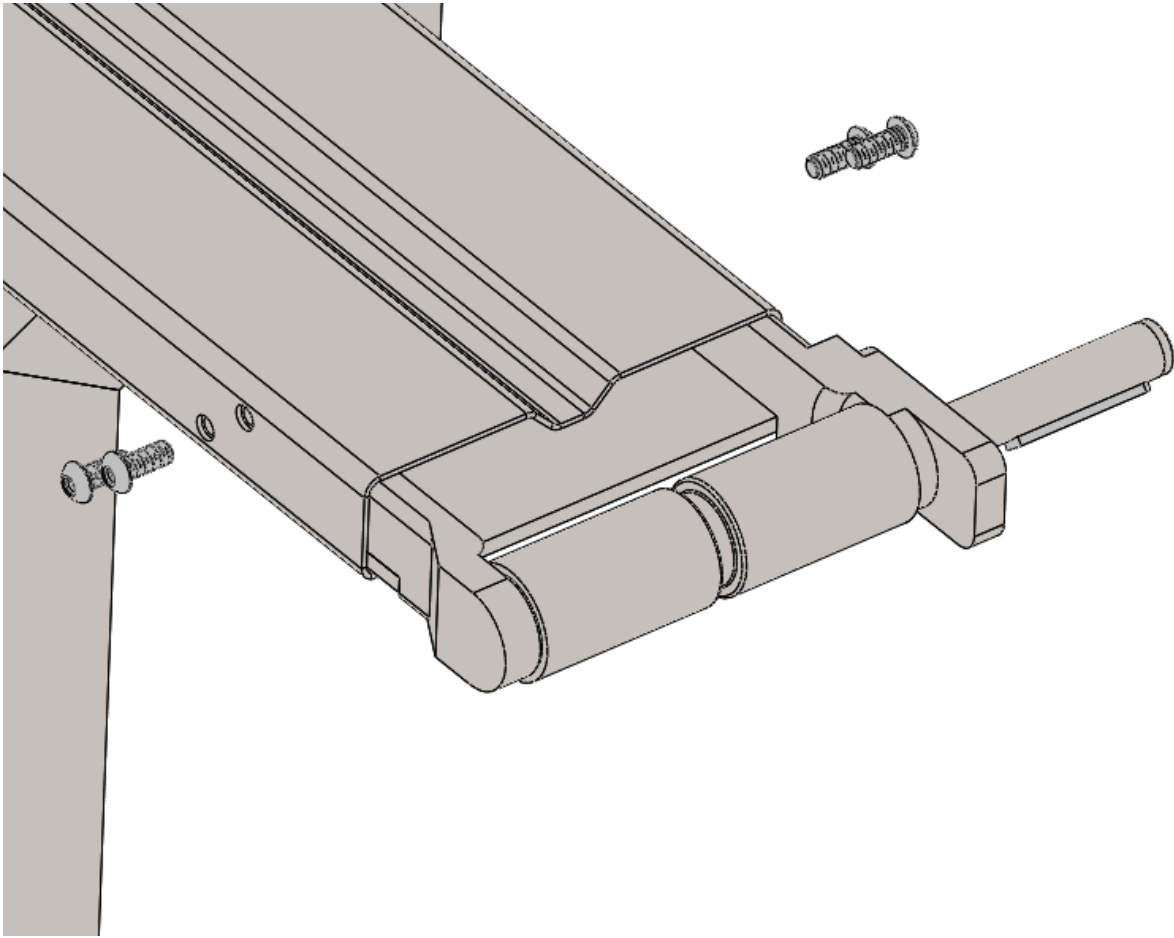

- Grab the roller and slide the entire motor assembly out of the conveyor body. You may have to wiggle the assembly back and forth slightly as you pull it out.
- Set the assembly upside down on a table or workbench.

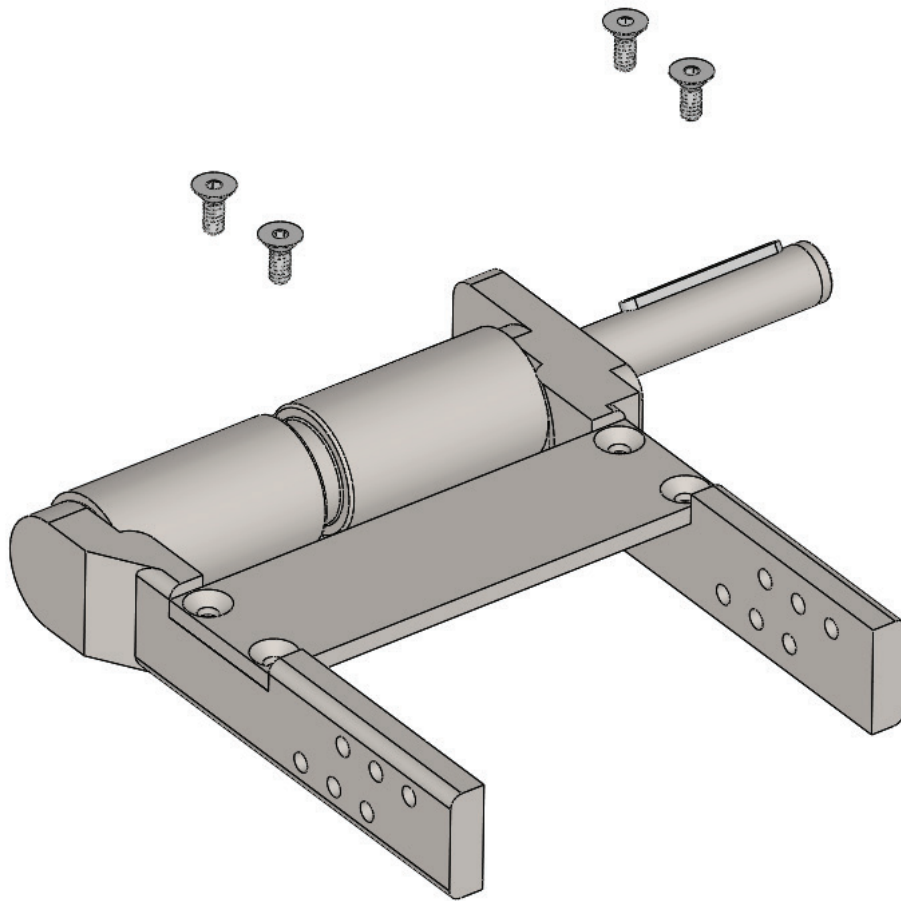

6. Using a 5/32 hex key, remove the 4 screws securing the plate to the two side arms.
7. With the plate removed, separate the arm with the problematic bearing. Remove the old bearing, and replace it with your new one. Then reinstall the plate you removed in the previous step.
8. Slide the motor assembly back into the conveyor body, and secure it with the 4 screws that were removed earlier. Note that there are 3 sets of holes on the side arms. We recommend that you install the screws through the middle set of holes.
9. Re-install the motor by sliding it on to the drive shaft. Ensure that the motor is in the orientation as shown, and that the keyway bore on the motor aligns with the key in the shaft. Secure the motor with the 4 bolts removed earlier.
10. Reinstall the belt and side panels.

CLEANING & MAINTENANCE

CLEANING THE CONVEYORS

Eteros conveyors are washdown rated and feature easily-removable conveyor belts. To clean the conveyor, proceed as follows:

1. Flip the power switch to the OFF position and disconnect the power cord.
2. Remove the hopper.
3. Remove the belt from the body of the conveyor.
4. Spray down or soak the belt in diluted degreaser for 5 - 10 minutes. If necessary, use a cloth or soft-bristled brush to remove stubborn soils. Rinse thoroughly (pressure washer ok) with warm or hot water (maximum 55oC/130oF) and allow to dry. Apply a sanitizer if necessary as part of your sanitation SOP.
5. Spritz metal body and frame with degreaser, allowing time for the degreaser to sit on surfaces and penetrate any soils. Use a cloth to remove any stubborn soils. Rinse thoroughly (pressure washer ok) with warm or hot water (maximum 55oC/130oF) and allow to dry. Take care to wash the underside of the conveyor where internal components are housed.
6. Do not pressure wash the CONTROL BOX. Use a damp cloth with warm water to remove any residue or buildup on the buttons and dial.
7. Reinstall the belt and hopper on to the machine.

PREVENTATIVE MAINTENANCE

Eteros recommends removing the side panels and belt to clean the machine daily as outlined in the CLEANING THE CONVEYORS section of this user guide. The side panels are designed to prevent plant matter from accumulating in unwanted areas if installed correctly, but some material may still enter these areas. Regularly inspect the machine to ensure unintended dirt buildup is not occurring.

SPECIFICATIONS

Wet / Dry Capable	Yes
Construction	304 Stainless Steel and Delrin
Belt Material	Matte White Polyurethane
Speed Adjustments	1-11
Belt Length	77"
Belt Width	5"
Motor	1/10 HP
Power Requirements	110 V, 1.5 A
Tools	Mobius tensioning tool (included)
Fits through standard door?	Yes
Length	66 - 1/2"
Height	65 - 1/4"
Width	26 - 1/4"



Eteros Technologies West
202-17665 66A Ave.
Surrey, BC
V3S 2A7

Eteros Technologies East
26 Industrial Ave.
Carleton Place, ON
K7C 3T2

1-866-874-6264
INFO@MOBIUSTRIMMER.COM
MOBIUSTRIMMER.COM