

PROJECT:	Magna-1	UNIT TAG:	_____	QUANTITY:	1
REPRESENTATIVE:	Hurley Engineering	TYPE OF SERVICE:	Stainless Steel Pump Configuration	DATE:	_____
ENGINEER:	TBD	SUBMITTED BY:	Devin Carle	DATE:	_____
CONTRACTOR:	TBD	APPROVED BY:	_____	DATE:	_____
		ORDER NO.:	_____	DATE:	_____

## MAGNA1 50-80 F N



MAGNA1 N is the stainless steel variant for applications where the media requires this (e.g. domestic hot water). With MAGNA1, the job is done in an intuitive and efficient way.

Product photo could vary from the actual product

Conditions of Service		Pump Data		Motor Data	
Flow:	68.1 US gpm	Maximum operating pressure:	174.05 psi	P1 max:	21 .. 336 W
Head:	15.55 ft	Liquid temperature range:	14 .. 230 °F	Rated voltage:	115 V
Efficiency:	58.4 %	Maximum ambient temperature:	104 °F	Main frequency:	60 Hz
Liquid:	Water	Approvals:	98544606	Enclosure class:	X4D
Temperature:	140 °F	Flange standard:	GF	Insulation class:	F
NPSH required:	ft	Pipe connection:	GF53		
Specific Gravity:	0.985	Product number:	On request		

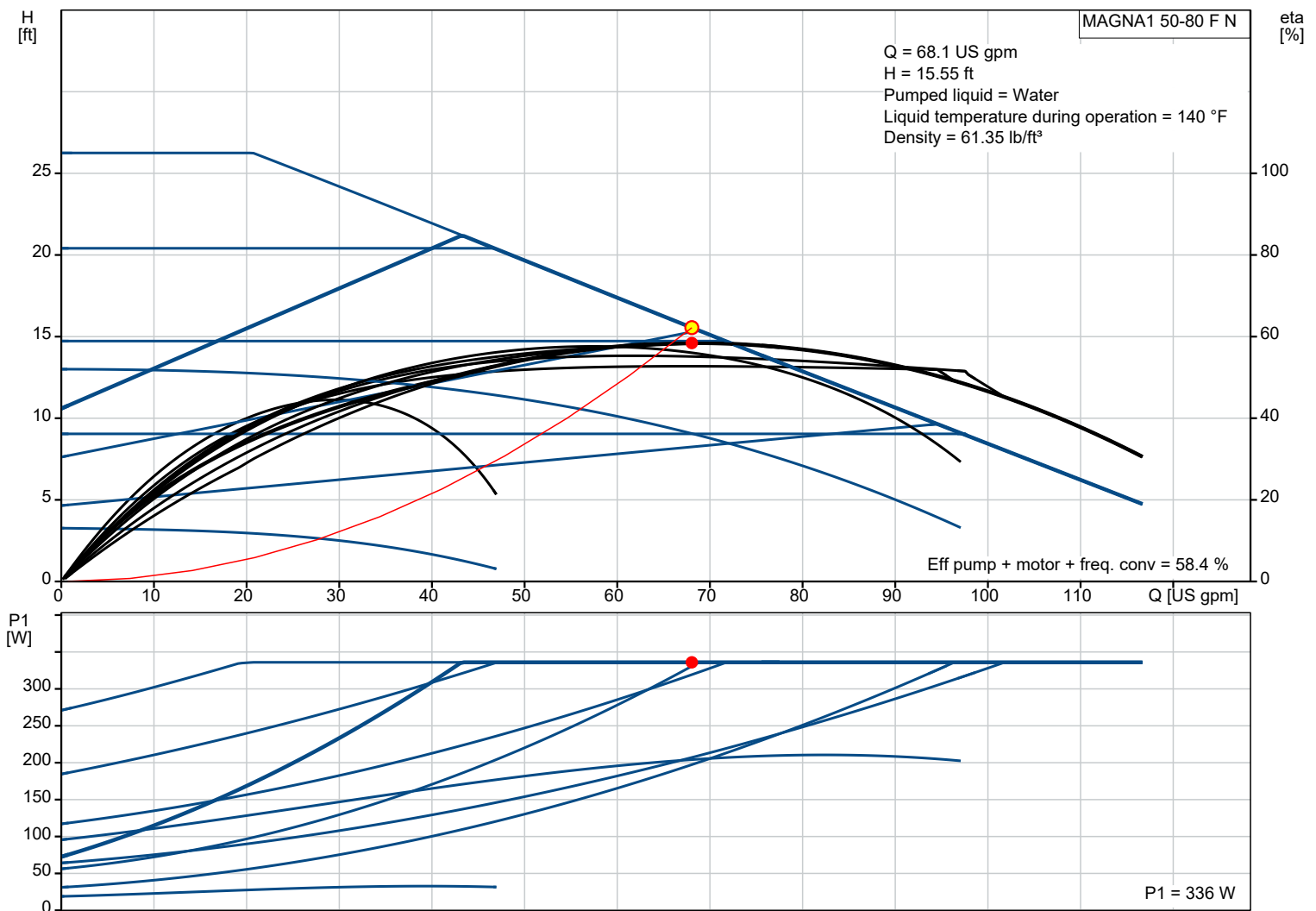

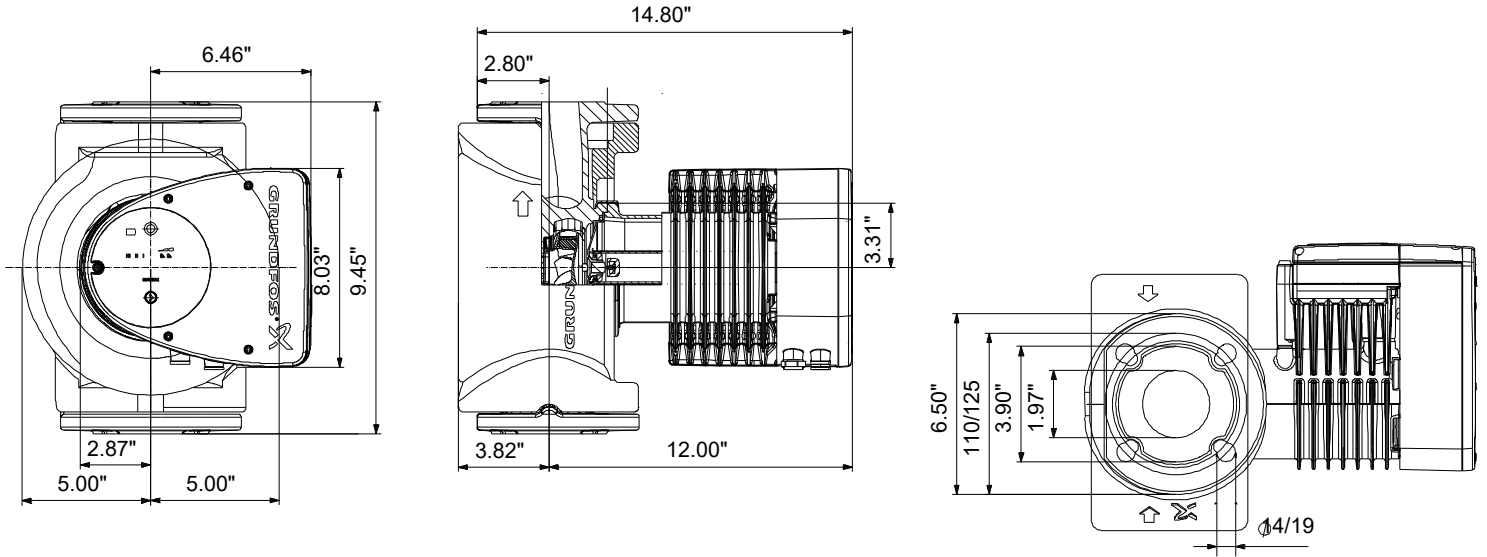

**Materials:**

- Pump housing: Stainless steel
- Pump housing: EN 1.4308
- Pump housing: ASTM 351 CF8
- Impeller: PES 30%GF

Count	Description
-------	-------------

1	<b>MAGNA1 50-80 F N</b>
---	-------------------------

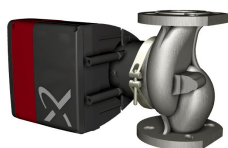

Product No.: On request

MAGNA1 circulator pump with easy selection of pump setting

The pump is of the canned-rotor type, i.e. pump and motor form an integral unit without shaft seal and with only two gaskets for sealing.

The bearings are lubricated by the pumped liquid.

In order to avoid problems in connection with disposal, great importance has been attached to using as few different materials as possible.

A pump with no maintenance requirements and extremely low life cycle cost.

Heating systems

- Main pump
- mixing loops
- heating surfaces
- air-conditioning surfaces.

The MAGNA1 circulator pumps are designed for circulating liquids in heating systems with variable flows where it is desirable to optimize the setting of the pump duty point, thus reducing energy costs. The pumps are also suitable for domestic hot-water systems.

To ensure correct operation, it is important that the sizing range of the system falls within the duty range of the pump.

The pump is also suitable for systems with hot-water priority as an external signal can

immediately force the pump to operate according to the max. curve, for example in solar-heating systems.

Benefits

- Safe selection.
- Simple installation.
- Low energy consumption. All MAGNA1 pumps comply with the EuP requirements.
- Nine light fields for indication of pump setting. Three proportional-pressure curves, three constant-pressure curves and three fixed-speed curves are available.
- Low noise level.
- No maintenance and long life.

Liquid:

Pumped liquid:	Water
Liquid temperature range:	14 .. 230 °F
Selected liquid temperature:	140 °F
Density:	61.35 lb/ft <sup>3</sup>

Technical:

Actual calculated flow:	68.1 US gpm
Resulting head of the pump:	15.55 ft
TF class:	110
Approvals on nameplate:	98544606

Materials:

Pump housing:	Stainless steel EN 1.4308 ASTM 351 CF8
Impeller:	PES 30%GF

Installation:

Range of ambient temperature:	32 .. 104 °F
Maximum operating pressure:	174.05 psi
Flange standard:	GF
Pipe connection:	GF53
Pressure stage:	PN12



Company name: Hurley Engineering

Created by:

Phone:

Date:

4/22/2021

Count	Description
	Port-to-port length: 9 1/2 in
	Electrical data:
	Power input - P1: 21 .. 336 W
	Main frequency: 60 Hz
	Rated voltage: 1 x 115 V
	Maximum current consumption: 0.32 .. 2.97 A
	Enclosure class (IEC 34-5): X4D
	Insulation class (IEC 85): F
	Others:
	Energy (EEI): 0.19
	Net weight: 39 lb
	Gross weight: 43.6 lb
	Shipping volume: 1.62 ft <sup>3</sup>
	Country of origin: US
	Custom tariff no.: 8413.70.2005

## On request MAGNA1 50-80 F N 60 Hz

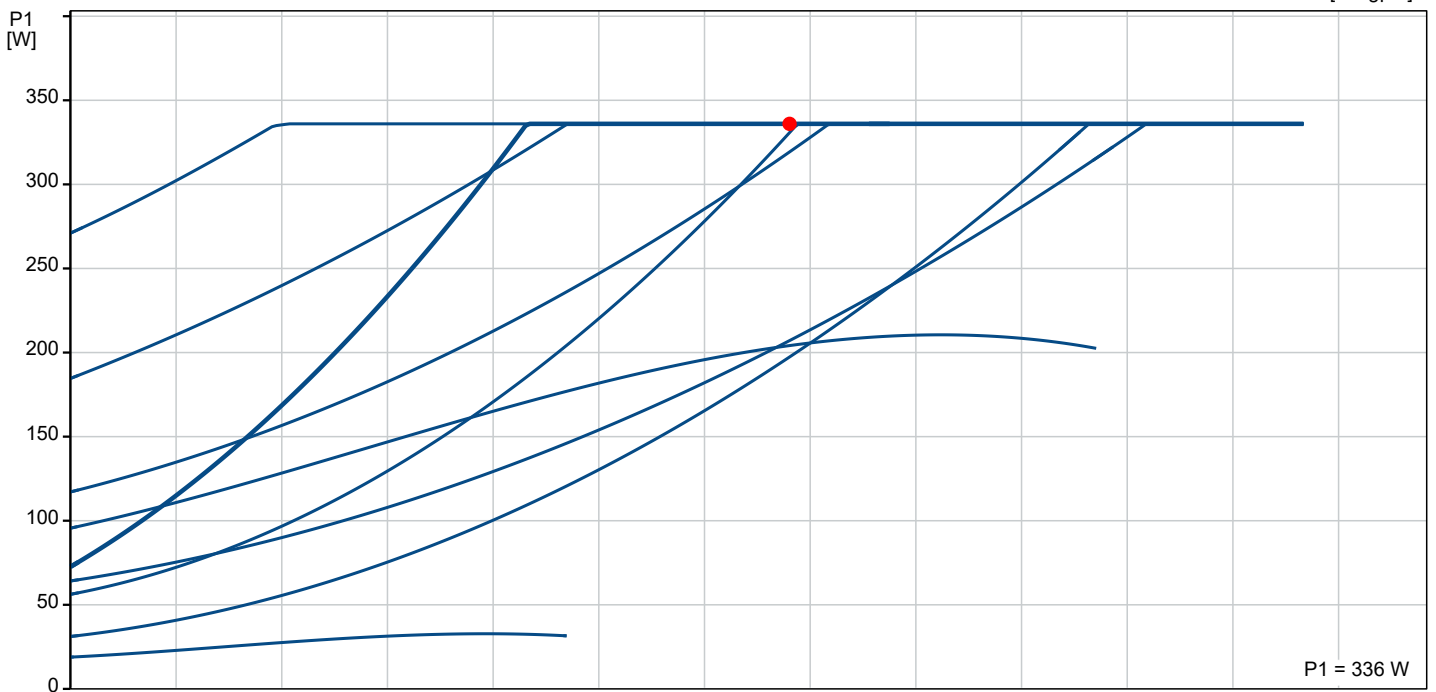
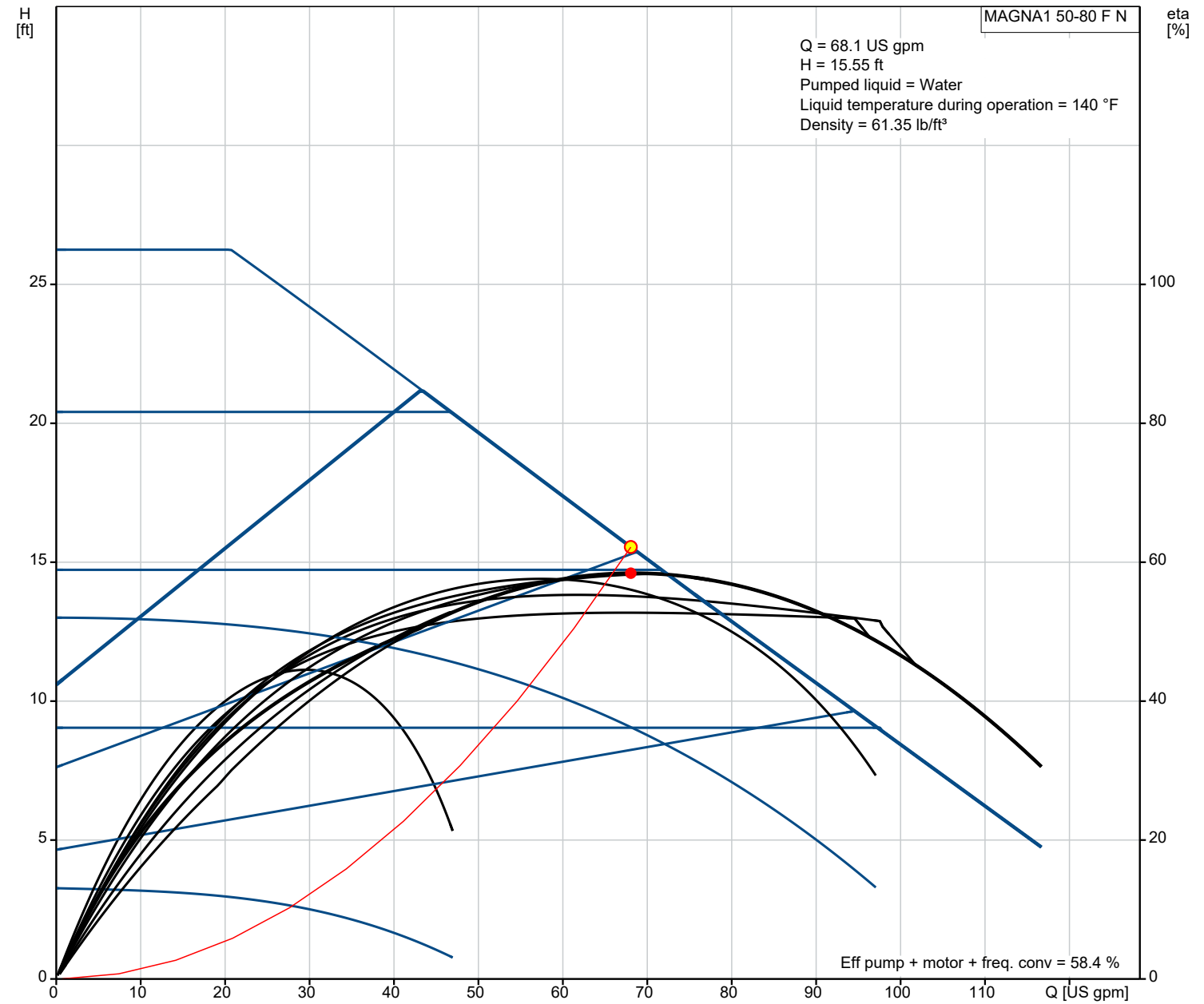

Description	Value
<b>General information:</b>	
Product name:	MAGNA1 50-80 F N
Product No.:	On request
EAN:	On request
<b>Technical:</b>	
Actual calculated flow:	68.1 US gpm
Resulting head of the pump:	15.55 ft
Head max:	26.25 ft
TF class:	110
Approvals on nameplate:	98544606
Model:	B
<b>Materials:</b>	
Pump housing:	Stainless steel
Pump housing:	EN 1.4308
Pump housing:	ASTM 351 CF8
Impeller:	PES 30%GF
<b>Installation:</b>	
Range of ambient temperature:	32 .. 104 °F
Maximum operating pressure:	174.05 psi
Flange standard:	GF
Pipe connection:	GF53
Pressure stage:	PN12
Port-to-port length:	9 1/2 in
<b>Liquid:</b>	
Pumped liquid:	Water
Liquid temperature range:	14 .. 230 °F
Selected liquid temperature:	140 °F
Density:	61.35 lb/ft³
<b>Electrical data:</b>	
Power input - P1:	21 .. 336 W
Main frequency:	60 Hz
Rated voltage:	1 x 115 V
Maximum current consumption:	0.32 .. 2.97 A
Enclosure class (IEC 34-5):	X4D
Insulation class (IEC 85):	F
<b>Others:</b>	
Energy (EEL):	0.19
Net weight:	39 lb
Gross weight:	43.6 lb
Shipping volume:	1.62 ft³
Country of origin:	US
Custom tariff no.:	8413.70.2005

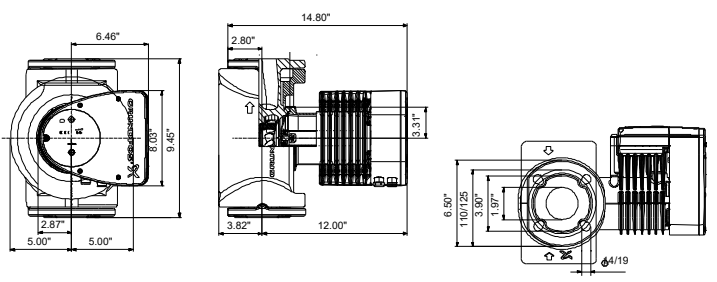
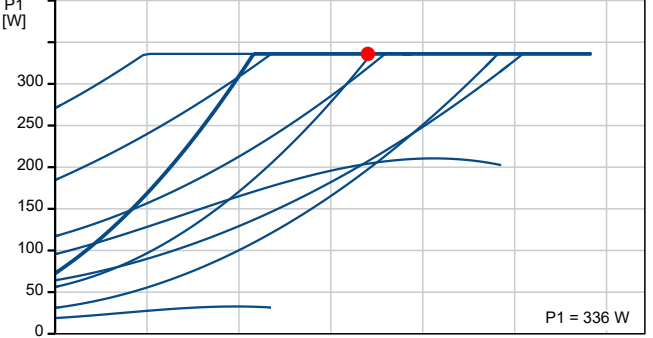
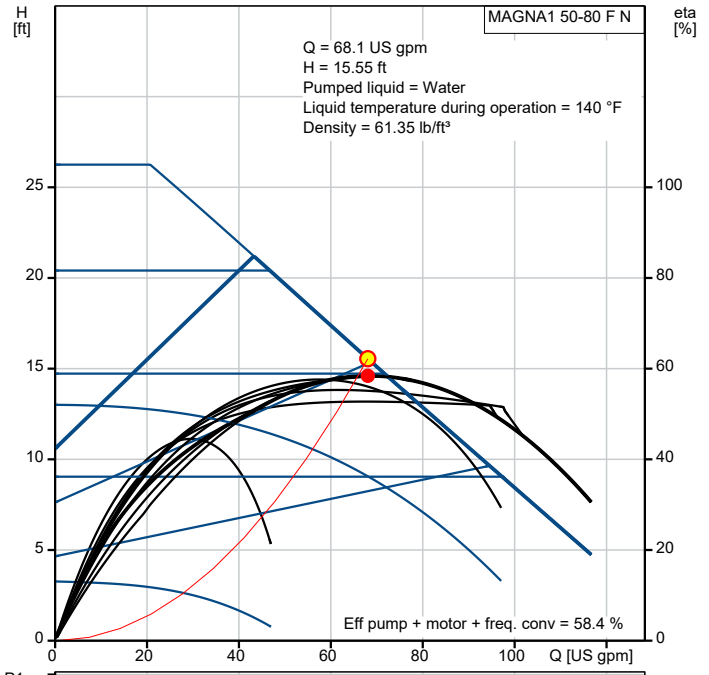

Example of mains-connected motor with mains switch, backup fuse and additional protection

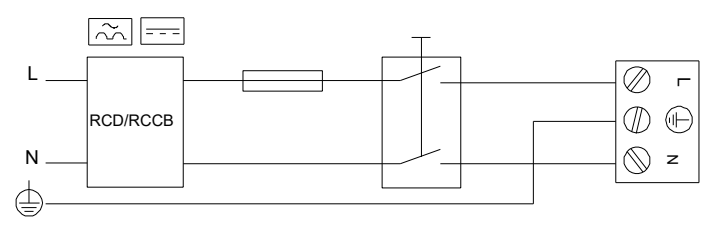

## On request MAGNA1 50-80 F N 60 Hz

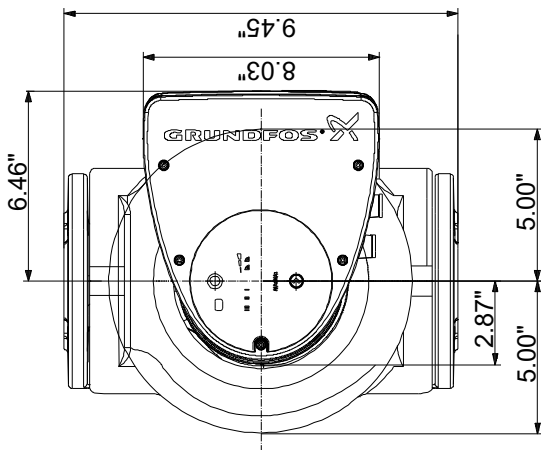
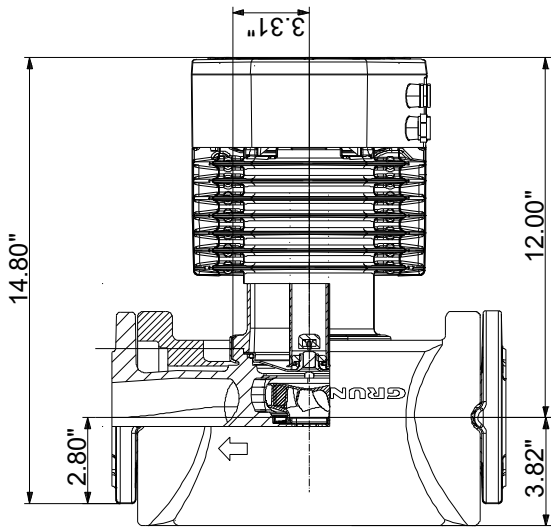
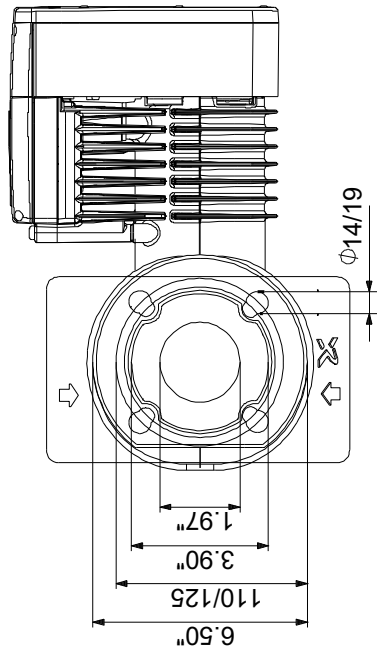

## On request MAGNA1 50-80 F N 60 Hz

Example of mains-connected motor  
with mains switch, backup fuse and additional protection

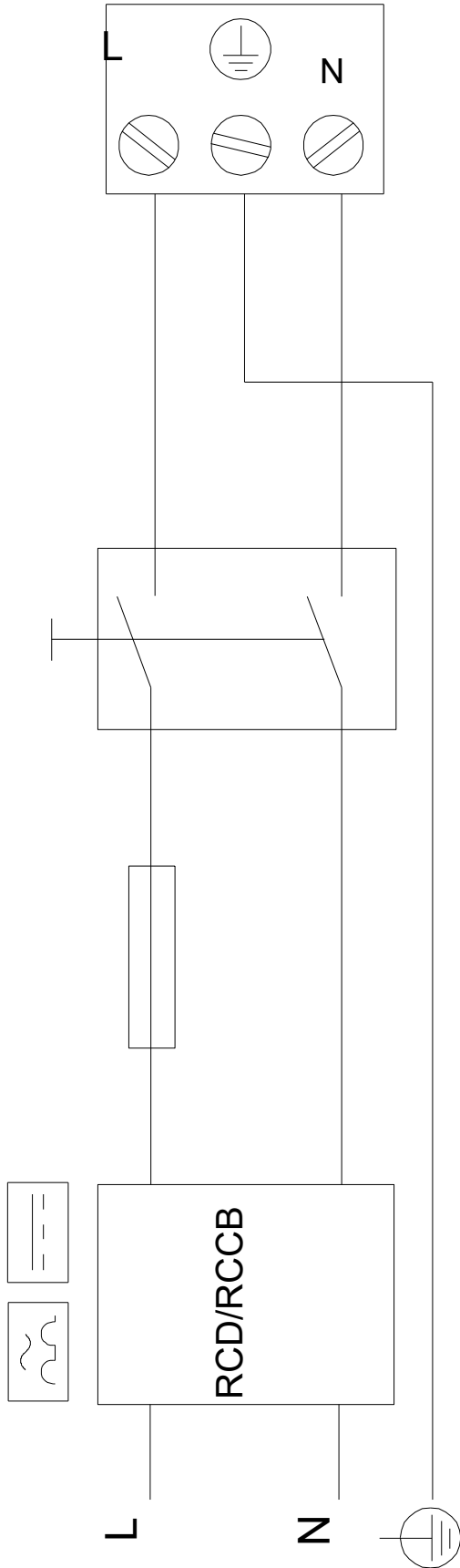





**Company name:** Hurley Engineering

**Created by:**

**Phone:**

**Date:**

4/22/2021

---

**Order Data:**

Product name: MAGNA1 50-80 F N

Amount: 1

Product No.: On request

Total: Price on request

---