

PROJECT:	Magna-1	UNIT TAG:	_____	QUANTITY:	1
REPRESENTATIVE:	Hurley Engineering	TYPE OF SERVICE:	Cast Iron Pump Configuration	DATE:	_____
ENGINEER:	TBD	SUBMITTED BY:	Devin Carle	DATE:	_____
CONTRACTOR:	TBD	APPROVED BY:	_____	DATE:	_____
		ORDER NO.:	_____	DATE:	_____



MAGNA1 80-100 F

The simple option for a job well done. The product has an intuitive user interface, which is especially fit for replacement of older circulators. The ideal choice for basic functionality needs.

Product photo could vary from the actual product

Conditions of Service		Pump Data		Motor Data	
Flow:	138 US gpm	Maximum operating pressure:	174.05 psi	P1 max:	31 .. 1014 W
Head:	24.91 ft	Liquid temperature range:	14 .. 230 °F	Rated voltage:	208-230 V
Efficiency:	64.3 %	Maximum ambient temperature:	104 °F	Main frequency:	60 Hz
Liquid:	Water	Approvals:	98544607	Enclosure class:	X4D
Temperature:	140 °F	Flange standard:	GF	Insulation class:	F
NPSH required:	ft	Pipe connection:	GF80		
Specific Gravity:	0.985	Product number:	On request		

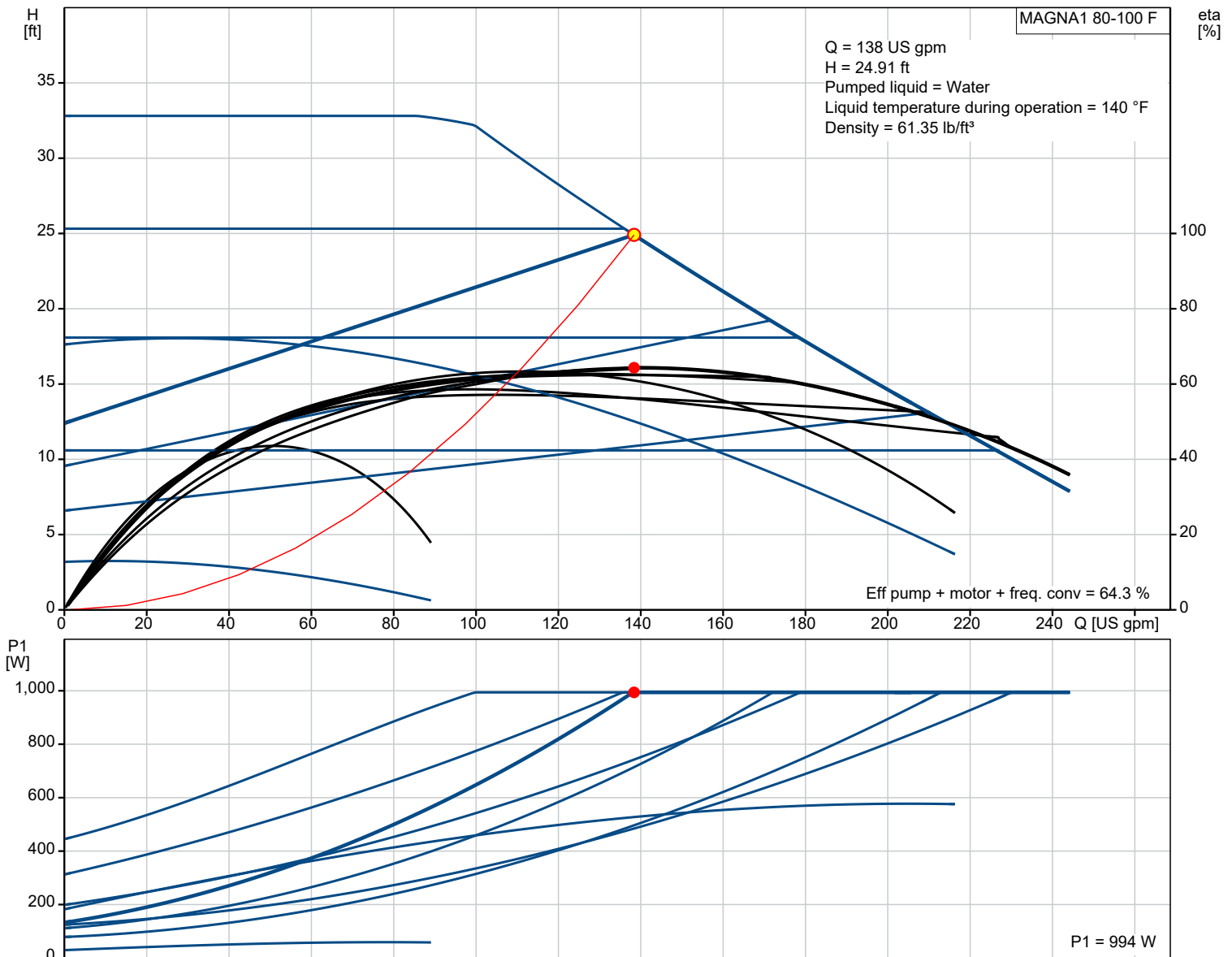

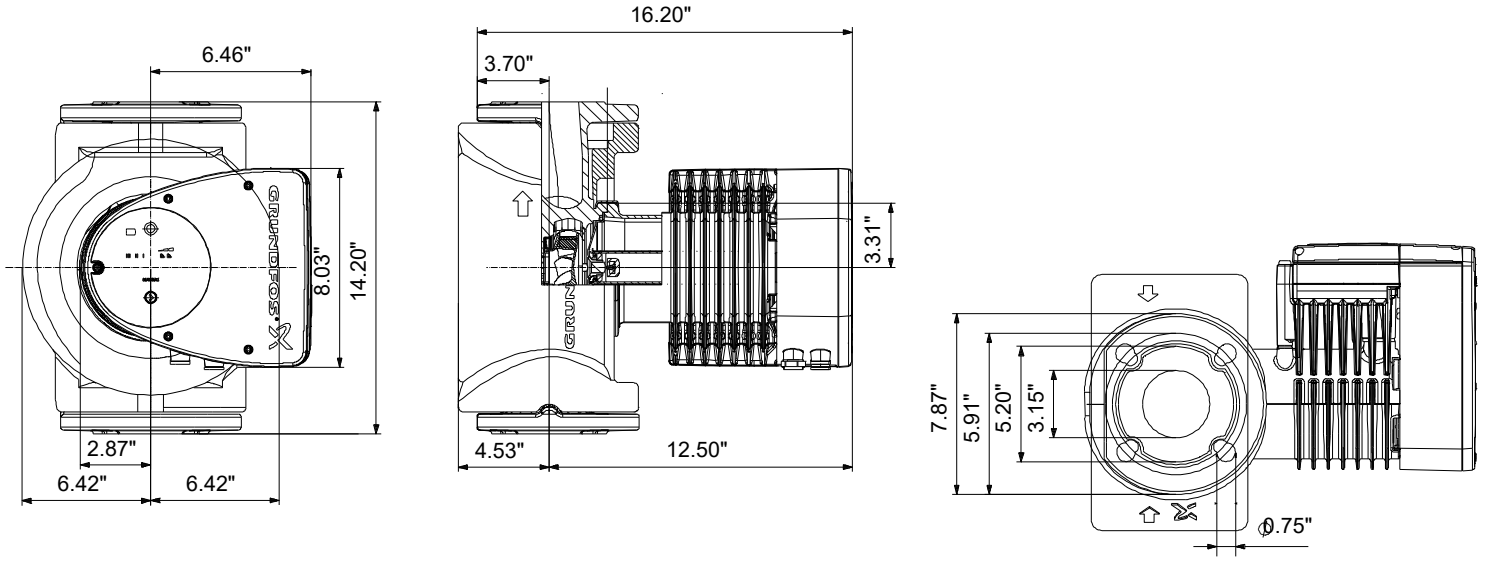

Materials:

- Pump housing: Cast iron
- Pump housing: EN-GJL-250
- Pump housing: ASTM A48-250B
- Impeller: PES 30%GF

Count	Description																														
1	<p data-bbox="121 235 328 262">MAGNA1 80-100 F</p> <div data-bbox="209 324 408 499" data-label="Image"> </div> <p data-bbox="121 555 395 582">Product No.: On request</p> <p data-bbox="121 613 1576 672">MAGNA1 circulator pump with easy selection of pump setting The pump is of the canned-rotor type, i.e. pump and motor form an integral unit without shaft seal and with only two gaskets for sealing.</p> <p data-bbox="121 703 1497 815">The bearings are lubricated by the pumped liquid. In order to avoid problems in connection with disposal, great importance has been attached to using as few different materials as possible. A pump with no maintenance requirements and extremely low life cycle cost.</p> <p data-bbox="121 846 300 873">Heating systems</p> <ul data-bbox="121 882 402 994" style="list-style-type: none"> • Main pump • mixing loops • heating surfaces • air-conditioning surfaces. <p data-bbox="121 1003 1497 1075">The MAGNA1 circulator pumps are designed for circulating liquids in heating systems with variable flows where it is desirable to optimize the setting of the pump duty point, thus reducing energy costs. The pumps are also suitable for domestic hot-water systems.</p> <p data-bbox="121 1084 1369 1196">To ensure correct operation, it is important that the sizing range of the system falls within the duty range of the pump. The pump is also suitable for systems with hot-water priority as an external signal can immediately force the pump to operate according to the max. curve, for example in solar-heating systems.</p> <p data-bbox="121 1232 210 1258">Benefits</p> <ul data-bbox="121 1267 1465 1469" style="list-style-type: none"> • Safe selection. • Simple installation. • Low energy consumption. All MAGNA1 pumps comply with the EuP requirements. • Nine light fields for indication of pump setting. Three proportional-pressure curves, three constant-pressure curves and three fixed-speed curves are available. • Low noise level. • No maintenance and long life. <p data-bbox="121 1500 194 1527">Liquid:</p> <table data-bbox="121 1536 609 1648"> <tr> <td>Pumped liquid:</td> <td>Water</td> </tr> <tr> <td>Liquid temperature range:</td> <td>14 .. 230 °F</td> </tr> <tr> <td>Selected liquid temperature:</td> <td>140 °F</td> </tr> <tr> <td>Density:</td> <td>61.35 lb/ft³</td> </tr> </table> <p data-bbox="121 1680 233 1706">Technical:</p> <table data-bbox="121 1715 619 1827"> <tr> <td>Actual calculated flow:</td> <td>138 US gpm</td> </tr> <tr> <td>Resulting head of the pump:</td> <td>24.91 ft</td> </tr> <tr> <td>TF class:</td> <td>110</td> </tr> <tr> <td>Approvals on nameplate:</td> <td>98544607</td> </tr> </table> <p data-bbox="121 1859 226 1886">Materials:</p> <table data-bbox="121 1895 667 2007"> <tr> <td>Pump housing:</td> <td>Cast iron EN-GJL-250 ASTM A48-250B</td> </tr> <tr> <td>Impeller:</td> <td>PES 30%GF</td> </tr> </table> <p data-bbox="121 2038 242 2065">Installation:</p> <table data-bbox="121 2074 609 2208"> <tr> <td>Range of ambient temperature:</td> <td>32 .. 104 °F</td> </tr> <tr> <td>Maximum operating pressure:</td> <td>174.05 psi</td> </tr> <tr> <td>Flange standard:</td> <td>GF</td> </tr> <tr> <td>Pipe connection:</td> <td>GF80</td> </tr> <tr> <td>Pressure stage:</td> <td>PN12</td> </tr> </table>	Pumped liquid:	Water	Liquid temperature range:	14 .. 230 °F	Selected liquid temperature:	140 °F	Density:	61.35 lb/ft ³	Actual calculated flow:	138 US gpm	Resulting head of the pump:	24.91 ft	TF class:	110	Approvals on nameplate:	98544607	Pump housing:	Cast iron EN-GJL-250 ASTM A48-250B	Impeller:	PES 30%GF	Range of ambient temperature:	32 .. 104 °F	Maximum operating pressure:	174.05 psi	Flange standard:	GF	Pipe connection:	GF80	Pressure stage:	PN12
Pumped liquid:	Water																														
Liquid temperature range:	14 .. 230 °F																														
Selected liquid temperature:	140 °F																														
Density:	61.35 lb/ft ³																														
Actual calculated flow:	138 US gpm																														
Resulting head of the pump:	24.91 ft																														
TF class:	110																														
Approvals on nameplate:	98544607																														
Pump housing:	Cast iron EN-GJL-250 ASTM A48-250B																														
Impeller:	PES 30%GF																														
Range of ambient temperature:	32 .. 104 °F																														
Maximum operating pressure:	174.05 psi																														
Flange standard:	GF																														
Pipe connection:	GF80																														
Pressure stage:	PN12																														



Company name: Hurley Engineering

Created by:

Phone:

Date:

4/22/2021

Count	Description
	Port-to-port length: 14 3/16 in
	Electrical data:
	Power input - P1: 31 .. 1014 W
	Main frequency: 60 Hz
	Rated voltage: 1 x 208-230 V
	Maximum current consumption: 0.31 .. 4.45 A
	Enclosure class (IEC 34-5): X4D
	Insulation class (IEC 85): F
	Others:
	Energy (EEI): 0.19
	Net weight: 66.6 lb
	Gross weight: 71.8 lb
	Shipping volume: 2.37 ft ³
	Country of origin: US
	Custom tariff no.: 8413.70.2015

On request MAGNA1 80-100 F 60 Hz

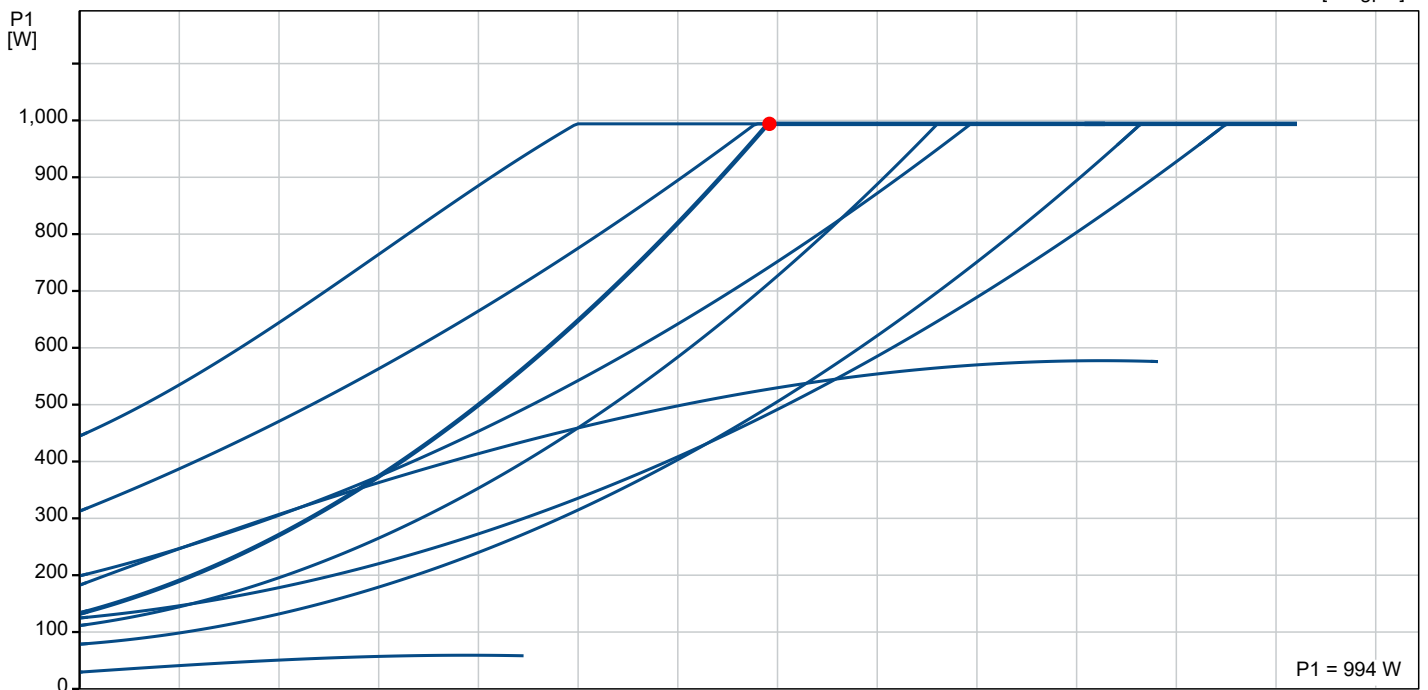
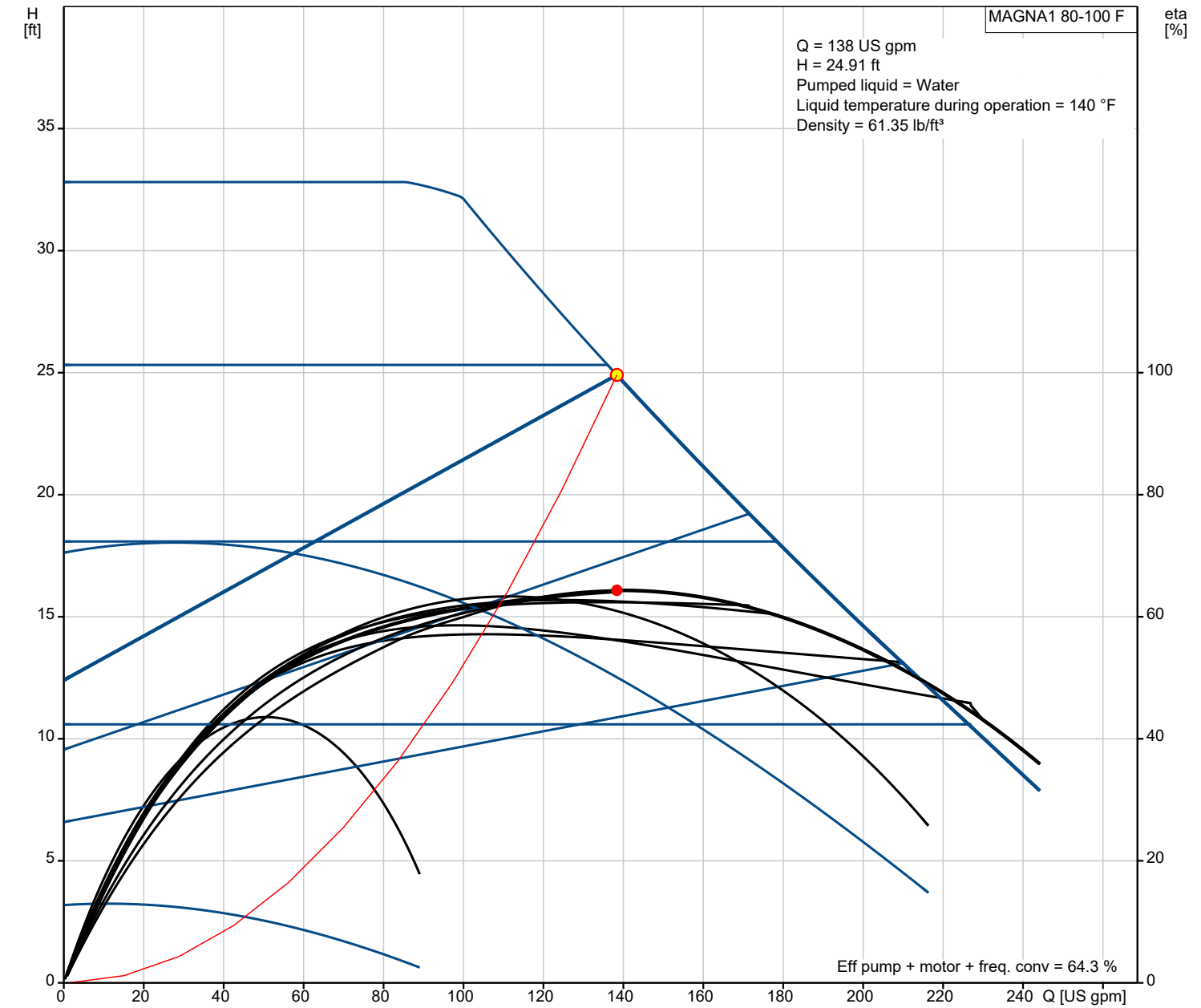

Description	Value
General information:	
Product name:	MAGNA1 80-100 F
Product No.:	On request
EAN:	On request
Technical:	
Actual calculated flow:	138 US gpm
Resulting head of the pump:	24.91 ft
Head max:	32.81 ft
TF class:	110
Approvals on nameplate:	98544607
Model:	B
Materials:	
Pump housing:	Cast iron
Pump housing:	EN-GJL-250
Pump housing:	ASTM A48-250B
Impeller:	PES 30%GF
Installation:	
Range of ambient temperature:	32 .. 104 °F
Maximum operating pressure:	174.05 psi
Flange standard:	GF
Pipe connection:	GF80
Pressure stage:	PN12
Port-to-port length:	14 3/16 in
Liquid:	
Pumped liquid:	Water
Liquid temperature range:	14 .. 230 °F
Selected liquid temperature:	140 °F
Density:	61.35 lb/ft³
Electrical data:	
Power input - P1:	31 .. 1014 W
Main frequency:	60 Hz
Rated voltage:	1 x 208-230 V
Maximum current consumption:	0.31 .. 4.45 A
Enclosure class (IEC 34-5):	X4D
Insulation class (IEC 85):	F
Others:	
Energy (EEL):	0.19
Net weight:	66.6 lb
Gross weight:	71.8 lb
Shipping volume:	2.37 ft³
Country of origin:	US
Custom tariff no.:	8413.70.2015

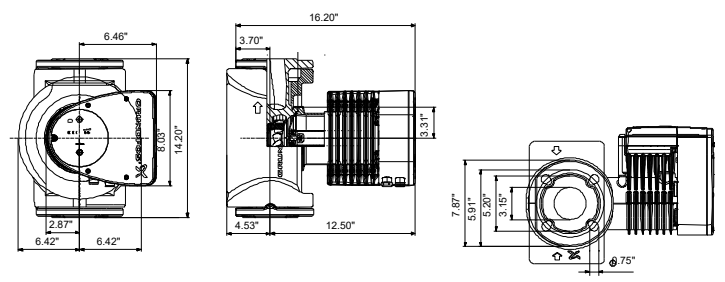
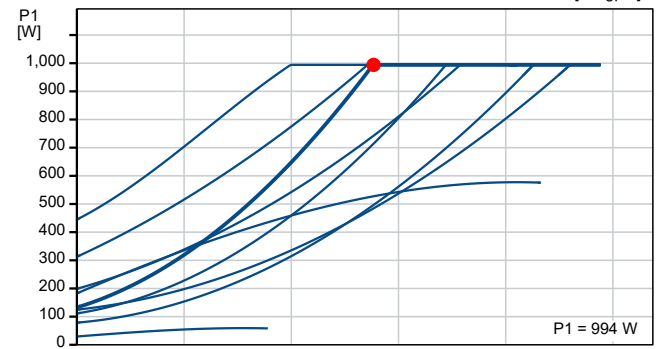
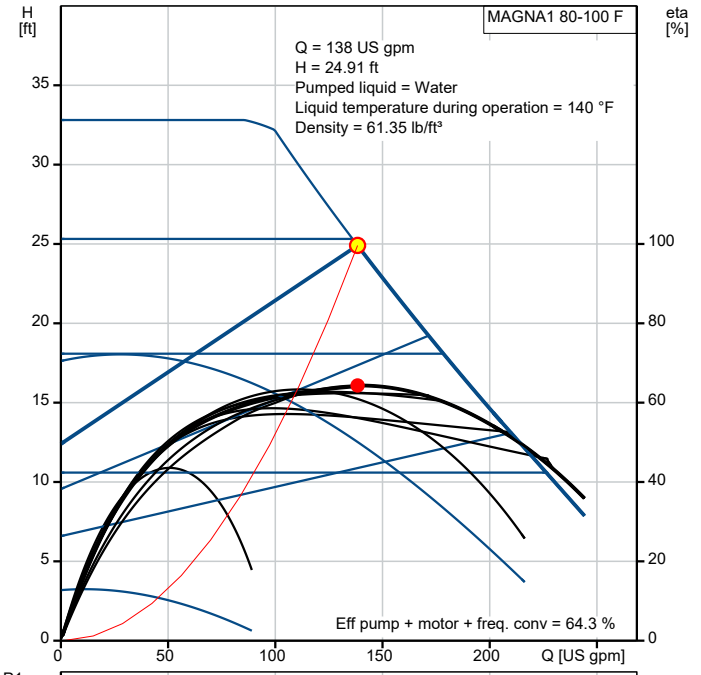

Example of mains-connected motor with mains switch, backup fuse and additional protection

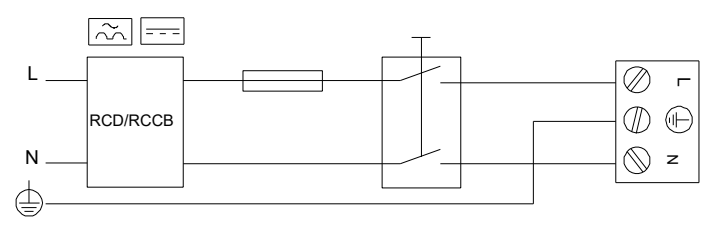

On request MAGNA1 80-100 F 60 Hz

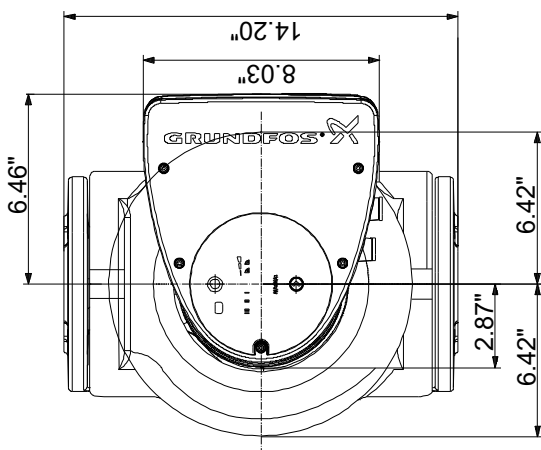
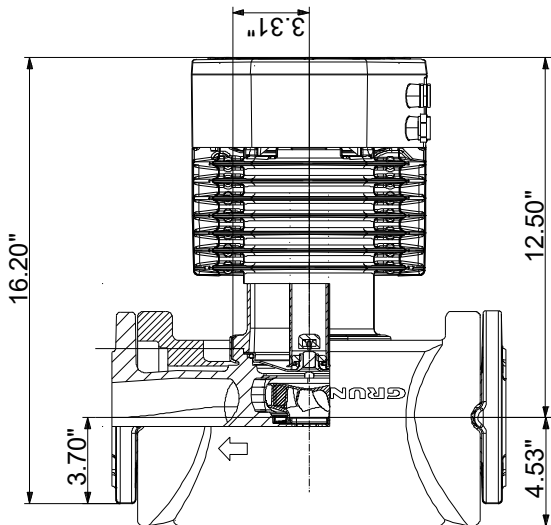
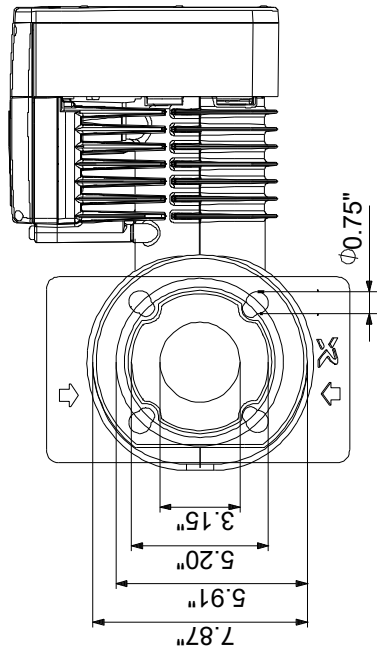

On request MAGNA1 80-100 F 60 Hz

Example of mains-connected motor
with mains switch, backup fuse and additional protection

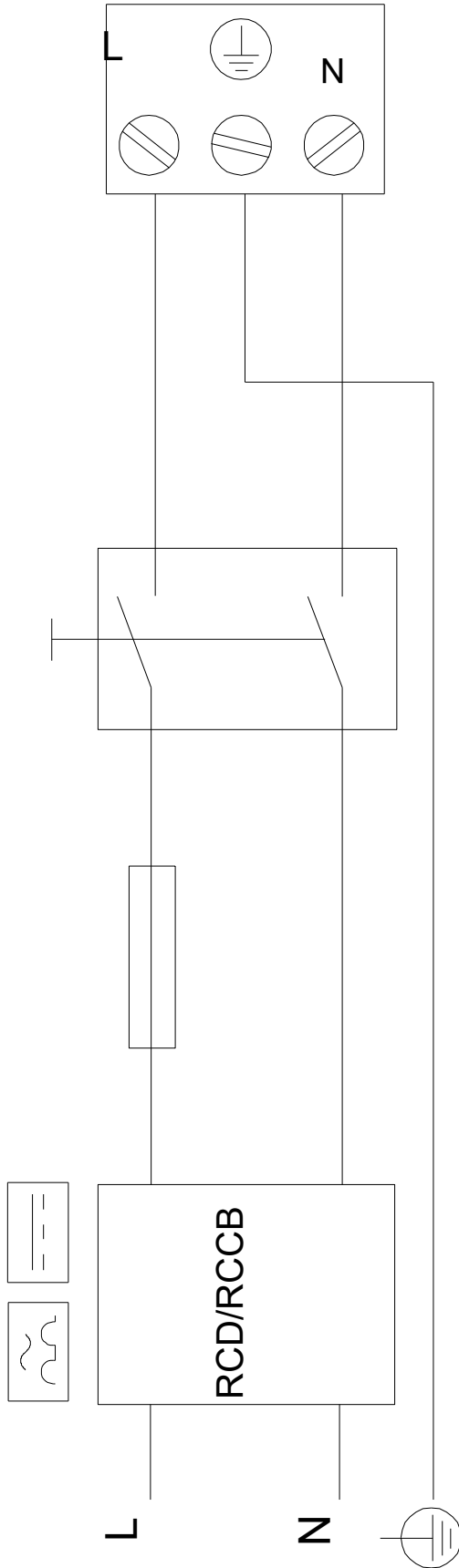



Company name: Hurley Engineering

Created by:

Phone:

Date:

4/22/2021

Order Data:

Product name: MAGNA1 80-100 F

Amount: 1

Product No.: On request

Total: Price on request
