

The
**Trademark
Reporter**[®]



The Law Journal of the International Trademark Association

United States Annual Review

**The Seventy-Second Year of Administration
of the Lanham Act of 1946**

Theodore H. Davis Jr.
John L. Welch

INTERNATIONAL TRADEMARK ASSOCIATION

Powerful Network Powerful Brands

675 Third Avenue, New York, NY 10017-5704

Telephone: +1 (212) 642-1733

email: tmr@inta.org

Facsimile: +1 (212) 768-7796

OFFICERS OF THE ASSOCIATION

AYALA DEUTSCH.....*President*
TIKI DARE*President-Elect*
ZEEGER VINK.....*Vice President*
JOMARIE FREDERICKS.....*Vice President*
DANA NORTHCOTT.....*Treasurer*
ELISABETH BRADLEY.....*Secretary*
ERIN HENNESSY*Counsel*
ETIENNE SANZ DE ACEDO*Chief Executive Officer*

The Trademark Reporter Committee

EDITORIAL BOARD

EDITOR-IN-CHIEF, CHAIR

GLENN MITCHELL

STAFF EDITOR-IN-CHIEF

WILLARD KNOX

Senior Editors

RAFFI V. ZEROUNIAN

PAMELA S. CHESTEK

BRYAN K. WHEELOCK

KAREN ELBURG

VERENA VON BOMHARD

FABRIZIO MIAZZETTO

ANDREW J. GRAY

LESLEY GROSSBERG

Director of Legal Resources

LIZ HANELLIN

Senior Staff Editor

BEVERLY HARRIS

Staff Editor

ELIZABETH VENTURO

Senior Legal Editor

ROSEMARY DESTEFANO

Senior Coordinator, Digital Content

SHANNON FRITSCHÉ

Composer

BARBARA MOTTER

Editors

THOMAS AGNELLO
EUGENY ALEXANDROV
TARA ALLSTUN
CHARLENE AZEMA
MARTIN BERAN
DANIEL BERESKIN
SUBHASH BHUTORIA
JULIAN BIBB
STEPHANIE BUNTIN
ROBERT CAMERON
JEANNETTE CARMADDELLA
JACQUELINE CHORN
THEODORE DAVIS
MICHAEL DENNISTON
CATHERINE ESCOBEDO
DÉSIRÉE FIELDS
ALFRED FRAWLEY
ALEXANDRA GEORGE
STUART GREEN
STACY GROSSMAN

JORDI GÜELL
MICHAEL HANDLER
NATHAN HARRIS
BARRY HORWITZ
GANG HU
BRUCE ISAACSON
SIEGRUN KANE
INGRIDA KARINA-BERZINA
ELISABETH KASZMAR FEKETE
SONIA KATYAL
LINDSAY KOROTKIN
SENTHIL KUMAR
SCOTT LEBSON
SONAL MADAN
J.DAVID MAYBERRY
BRYCE MAYNARD
JAMES MCALLISTER
J. THOMAS MCCARTHY
CATHERINE MITROS
GAIL NEVIUS ABBAS

SHANA OLSON
R. TERRY PARKER
LUIS HENRIQUE PORANGABA
YASHVARDHAN RANA
BRANDON RESS
RICHARD RIVERA
SUSAN RUSSELL
CHELSEA RUSSELL
FLORIAN SCHWAB
TOM SCOURFIELD
RINITA SIRCAR
GIULIO ENRICO SIRONI
RANDY SPRINGER
CORY STRUBLE
MARTIN VIEFHUES
JEFFREY WAKOLBINGER
RITA WEEKS
JOHN WELCH
MARTIN WIRTZ
RUMENG ZHANG

Advisory Board

MILES ALEXANDER
WILLIAM BORCHARD
CLIFFORD BROWNING
LANNING BRYER
JESSICA CARDON
SANDRA EDELMAN
ANTHONY FLETCHER

ROBERT KUNSTADT
THEODORE MAX
KATHLEEN MCCARTHY
JONATHAN MOSKIN
VINCENT PALLADINO
JOHN PEGRAM

ROBERT RASKOPF
PASQUALE RAZZANO
SUSAN REISS
PIER LUIGI RONCAGLIA
HOWARD SHIRE
JERRE SWANN, SR.
STEVEN WEINBERG

The views expressed in *The Trademark Reporter* (TMR) do not necessarily reflect those of INTA. To fulfill its mission of delivering cutting-edge scholarship on trademarks, brands, and related intellectual property to its readers, the TMR sources content reflecting a diversity of viewpoints; the views expressed in any given article, commentary, or book review are those of the individual authors..

The Trademark Reporter (ISSN 0041-056X) is published electronically six times a year by the International Trademark Association, 675 Third Avenue, New York, NY 10017-5704 USA. INTA, the INTA logo, INTERNATIONAL TRADEMARK ASSOCIATION, POWERFUL NETWORK POWERFUL BRANDS, THE TRADEMARK REPORTER, and inta.org are trademarks, service marks, and/or registered trademarks of the International Trademark Association in the United States and certain other jurisdictions.

The Trademark Reporter®

(USPS 636-080)

Copyright 2020, by the International Trademark Association
All Rights Reserved

Vol. 110

January–February, 2020

No. 1

TABLE OF CONTENTS

UNITED STATES ANNUAL REVIEW

The Seventy-Second Year of Administration of the Lanham Act of 1946

Theodore H. Davis Jr. and John L. Welch

Introduction	1
Part I. Ex Parte Cases.....	8
A. United States Supreme Court	8
1. Section 2(a) Scandalous or Immoral.....	8
B. United States Court of Appeals for the Federal Circuit.....	11
1. Section 2(d) Likelihood of Confusion	11
2. Genericness.....	14
3. Specimen of Use.....	17
C. Trademark Trial and Appeal Board	19
1. Section 2(d) Likelihood of Confusion	19
a. Likelihood of Confusion Found	19
b. Likelihood of Confusion Not Found	22
2. Section 2(e)(1) Mere Descriptiveness	26
3. Section 2(e)(2) Primarily Geographically Descriptive	28
4. Section 2(f) Acquired Distinctiveness.....	30
5. Failure to Function.....	33
6. Phantom Mark.....	42
7. Unacceptable Specimen of Use	45
8. Genericness.....	47
9. Color Mark.....	55

Part II. Inter Partes Cases	59
A. United States Court of Appeals for the Federal Circuit.....	59
1. Section 2(d) Likelihood of Confusion	59
2. Section 2(e)(1) Mere Descriptiveness/Genericness	64
3. Section 2(f) Acquired Distinctiveness.....	67
B. Trademark Trial and Appeal Board	69
1. Section 2(c) Consent to Register	69
2. Section 2(e)(1) Mere Descriptiveness	70
3. Section 2(f) Acquired Distinctiveness.....	72
4. Abandonment.....	74
5. Dilution	77
6. Genericness.....	80
7. Lack of Bona Fide Intent.....	82
8. Standing.....	84
9. Concurrent Use.....	86
10. Procedural Issues	90
a. Pleading Abandonment	90
b. Timeliness Issues Under 2017 Rule Changes	92
c. Timeliness of Testimony Declaration Signature.....	94
d. Declaration Signed Abroad	95
11. Discovery and Motion Practice	96
a. Counting Interrogatories.....	96
b. Motion to Compel Proper Responses	98
c. Designations Under the Standard Protective Order ..	100
d. Extending the Discovery Period.....	103
e. Re-opening the Testimony Period.....	105
f. Cross-examination of Domestic Testimonial Declarant or Affiant.....	107
g. Cross-examination of a Foreign Testimony Declarant or Affiant.....	109
h. Sanctions for Misconduct	111
Part III. Litigation in the Federal Courts and State Courts of General Jurisdiction.....	114
A. Infringement, Unfair Competition, and Related Torts	114
1. Establishing Liability.....	114
a. Violations of Trademark and Service Mark Rights	114
i. Defining Claimed Marks.....	114
ii. Establishing Protectable Rights.....	118
(A) The Effect of Registrations on the Mark- Validity Inquiry.....	118

- (1) Federal Registrations 118
 - (2) State Registrations 120
 - (B) Ownership 121
 - (C) The Common-Law Requirements for Mark Validity 121
 - (1) Use in Commerce 121
 - (a) The Nature and Quality of Use in Commerce Necessary to Establish Protectable Rights 122
 - (b) Use Through Licensees 127
 - (c) Use-Based Geographic Rights 129
 - (2) Distinctiveness 133
 - (a) Determining the Inherent Distinctiveness of Verbal and Two-Dimensional Design Marks 133
 - (i) Generic Designations 133
 - (ii) Descriptive Marks 138
 - (iii) Suggestive Marks 141
 - (iv) Arbitrary Marks 143
 - (v) Coined or Fanciful Marks 143
 - (b) Determining the Inherent Distinctiveness of Trade Dress and Nontraditional Marks 144
 - (c) Acquired Distinctiveness 146
 - (i) Opinions Finding Acquired Distinctiveness 146
 - (ii) Opinions Declining to Find Acquired Distinctiveness 149
 - (iii) Opinions Deferring Resolution of the Acquired-Distinctiveness Inquiry 152
 - (d) Survey Evidence of Distinctiveness 155
 - (3) Nonfunctionality 157
 - (a) Utilitarian Nonfunctionality 157
 - (b) Aesthetic Nonfunctionality 162
- iii. Establishing Liability for Violations of Trademark and Service Mark Rights 165
 - (A) Actionable Uses in Commerce by Defendants 165
 - (1) Opinions Finding Actionable Uses in Commerce 165

(2) Opinions Declining to Find Actionable Uses in Commerce	168
(3) Opinions Deferring Resolution of the Actionable-Use-in-Commerce Inquiry	170
(B) Likelihood of Confusion	171
(1) The Standard Multifactor Test for Likelihood of Confusion	171
(a) Factors Considered.....	171
(i) The First Circuit	171
(ii) The Second Circuit.....	171
(iii) The Third Circuit	172
(iv) The Fourth Circuit	172
(v) The Fifth Circuit	172
(vi) The Sixth Circuit.....	173
(vii) The Seventh Circuit.....	173
(viii) The Eighth Circuit	174
(ix) The Ninth Circuit.....	174
(x) The Tenth Circuit.....	174
(xi) The Eleventh Circuit.....	175
(xii) The District of Columbia Circuit	175
(b) Findings and Holdings.....	175
(i) Opinions Finding Likelihood of Confusion on Motions for Preliminary Injunctive Relief	175
(ii) Opinions Finding Likelihood of Confusion as a Matter of Law	185
(iii) Opinions Finding Likelihood of Confusion After Trial	191
(iv) Opinions Finding No Likelihood of Confusion on Motions for Preliminary Injunctive Relief.....	197
(v) Opinions Finding No Likelihood of Confusion as a Matter of Law	199
(vi) Opinions Finding No Likelihood of Confusion After Trial.....	207

- (vii) Opinions Deferring Resolution of the Likelihood-of-Confusion Inquiry 210
 - (2) The First-Sale Doctrine and Likelihood of Confusion Arising from the Diversion or Alteration of Genuine Goods 215
 - (3) Survey Evidence of Actual or Likely Confusion..... 217
 - (C) Liability for the Trafficking in Goods and Services Associated with Counterfeit Imitations of Marks 223
 - (1) Civil Liability 223
 - (2) Criminal Liability 226
 - (D) Dilution..... 226
 - (1) Mark Fame and Distinctiveness 226
 - (a) Opinions Finding Mark Fame and Distinctiveness 227
 - (b) Opinions Declining to Find Mark Fame and Distinctiveness..... 229
 - (2) Actual or Likely Dilution..... 230
 - (a) Actual or Likely Dilution by Blurring 230
 - (b) Actual or Likely Dilution by Tarnishment..... 234
 - (E) Cybersquatting..... 237
 - (1) In Rem Actions..... 237
 - (2) In Personam Actions..... 237
 - b. Passing Off and Reverse Passing Off 241
 - i. Passing Off 241
 - ii. Reverse Passing Off 241
 - c. False Advertising..... 244
 - i. False Statements of Fact in Commercial Advertising and Promotion..... 246
 - (A) Actionable Statements of Fact 246
 - (B) Actionable Commercial Advertising and Promotion 251
 - (1) Opinions Finding Actionable Commercial Advertising and Promotion 251
 - (2) Opinions Declining to Find Actionable Commercial Advertising and Promotion..... 252

	(3) Opinions Deferring Resolution of the Actionable-Commercial-Advertising-and-Promotion Inquiry	254
	(C) Falsity	255
	(1) Opinions Finding Falsity	256
	(2) Opinions Declining to Find Falsity	262
	(3) Opinions Deferring Resolution of the Falsity Inquiry	265
	ii. Actual or Likely Deception	268
	iii. Materiality	272
	iv. Interstate Commerce	276
	v. Damage and Causation	276
d.	False Endorsement and Violations of the Right of Publicity	279
e.	Violations of Rights Under Other State-Law Causes of Action	284
	i. Preemption of State-Law Causes of Action	284
	ii. State-by-State Causes of Action	285
	(A) Illinois	285
	(B) Massachusetts	287
	(C) Nebraska	288
	(D) New York	289
	(E) South Carolina	292
	(F) South Dakota	293
	(G) Virginia	293
f.	Secondary Liability	294
g.	Individual Liability	296
h.	Liability for Procurement of Registrations Through False or Fraudulent Representations	299
2.	Defenses	300
	a. Legal Defenses	300
	i. Abandonment	300
	(A) Nonuse	300
	(B) Loss of Trademark Significance	303
	ii. Descriptive Fair Use	304
	iii. Nominative Fair Use	307
	iv. Fraudulent Declaration of Incontestability	311
	v. Statutes of Limitations	313
	vi. Violations of Antitrust Law	314
	b. Equitable Defenses	315
	i. Unclean Hands	315
	ii. Laches	318
	iii. Acquiescence	321

iv.	Estoppel	322
v.	Waiver.....	323
3.	Remedies	323
a.	Injunctive Relief.....	323
i.	Prerequisites for Injunctive Relief	323
(A)	Irreparable Harm.....	323
(B)	Inadequacy of Legal Remedies	333
(C)	Balance of Hardships.....	335
(D)	Public Interest.....	339
ii.	Terms of Injunctive Relief	340
iii.	Security.....	343
iv.	Contempt	345
b.	Monetary Relief	346
i.	Damages	346
(A)	Actual Damages	346
(1)	Eligibility of Prevailing Plaintiffs for Awards of Actual Damages	346
(2)	Calculation of Actual Damages	347
(B)	Statutory Damages	348
ii.	Accountings of Profits	352
(A)	Eligibility of Prevailing Plaintiffs for Accountings of Profits	352
(B)	The Accounting Process.....	357
iii.	Adjustments of Awards of Damages and Accountings of Profits	360
iv.	Prejudgment and Post-Judgment Interest	362
v.	Attorneys' Fees.....	362
(A)	Determination of the Prevailing Party	364
(B)	Eligibility of Prevailing Parties for Awards of Attorneys' Fees	365
(1)	Fee Requests by Prevailing Plaintiffs	365
(2)	Fee Requests by Prevailing Defendants	368
(C)	Calculation of Attorneys' Fees.....	372
B.	The Relationship Between Courts and the United States Patent and Trademark Office.....	374
1.	Judicial Review of, and Deference to, United States Patent and Trademark Office Determinations	374
2.	Judicial Authority Over Federal Registrations and Applications	377
C.	Constitutional Matters.....	384

1. Article III Case and Controversies	384
2. The First Amendment	387
3. The Seventh Amendment.....	391
4. The Eighth Amendment.....	394
D. Procedural Matters	395
1. Federal Subject-Matter Jurisdiction	395
2. Appellate Jurisdiction	397
3. Standing.....	398
a. Opinions Finding Standing	398
b. Opinions Declining to Find Standing	401
c. Opinions Deferring Resolution of the Standing Inquiry.....	403
4. Personal Jurisdiction.....	404
a. Opinions Exercising Personal Jurisdiction	405
b. Opinions Declining to Exercise Personal Jurisdiction	411
5. Venue	413
a. Opinions Finding Venue Proper	414
b. Opinions Declining to Find Venue Proper	417
6. Issue and Claim Preclusion	418
a. Issue Preclusion (Collateral Estoppel)	418
b. Claim Preclusion (Res Judicata).....	420
c. Judicial Estoppel	423
7. Indispensable Parties.....	423
8. Extraterritorial Applications of the Lanham Act	424
9. Sanctions.....	425
10. Arbitration	427
E. Evidentiary Matters.....	429
1. Admissibility of Expert Witness Testimony.....	429
2. Admissibility of Other Evidence and Testimony	430
F. Trademark- and Service Mark-Related Transactions.....	435
1. Interpretation and Enforcement of Trademark and Service Mark Assignments	435
2. Interpretation and Enforcement of Trademark and Service Mark Licenses.....	438
3. Interpretation and Enforcement of Settlement Agreements	442
G. The Relationship Between the Lanham Act and Other Statutes.....	444
1. The Copyright Act	444

2. The Bankruptcy Code.....	444
3. The Food, Drug, and Cosmetic Act	446
4. The Federal Trade Commission Act	449
H. Insurance-Related Issues.....	451
1. Opinions Ordering Coverage.....	451
2. Opinions Declining to Order Coverage.....	454

The Trademark Reporter®

UNITED STATES ANNUAL REVIEW

THE SEVENTY-SECOND YEAR OF ADMINISTRATION OF THE LANHAM ACT OF 1946*

INTRODUCTION

*By Theodore H. Davis Jr.***

In 1911, the Supreme Court of the United States issued four substantive trademark-related opinions in a twelve-month period.¹ In the one hundred nine years since then, the Court has never repeated that accomplishment, but the possibility exists of it doing so as this Review goes to print. Indeed, depending on the timing of

* The Annual Review is a continuation of the work originated in 1948 by Walter J. Derenberg and written by him through The Twenty-Fifth Year in 1972. This Review primarily covers opinions reported between July 1, 2018, and June 30, 2019, as well as certain proceedings falling outside that period.

** Author of the Introduction to, and Part III of, this Review; Partner, Kilpatrick Townsend & Stockton, LLP; member, Georgia, New York, and District of Columbia bars.

In the interest of full disclosure, the author notes his participation or that of his law firm in the following cases referenced by this Review: *Iancu v. Brunetti*, 139 S. Ct. 2294 (2019) (counsel for amicus curiae American Intellectual Property Law Association in support of neither party); *Mission Prod. Holdings, Inc. v. Tempnology, LLC*, 139 S. Ct. 1652 (2019) (counsel for amicus curiae American Intellectual Property Law Association in support of neither party); *Peter v. NantKwest*, 140 S. Ct. 365 (2019) (counsel for amicus curiae American Bar Association in support of respondent); *Booking.com B.V. v. United States Patent & Trademark Office*, 915 F.3d 171 (4th Cir. 2019), *as amended* (Feb. 27, 2019), *cert. granted*, No. 19-46, 2019 WL 5850636 (U.S. Nov. 11, 2019) (counsel for amicus curiae American Intellectual Property Law Association in support of petitioner); *Thompson v. Does 1-5*, 376 F. Supp. 3d 1322 (N.D. Ga. 2019) (counsel for plaintiff); *Engineered Arresting Systems Corp. v. Atech, Inc.*, 356 F. Supp. 3d 1323 (N.D. Ala. 2018) (counsel for plaintiff); *In re 1-800 Contacts, Inc.*, No. 9372, 2018 WL 6078349 (F.T.C. Nov. 14, 2018), *appeal docketed sub nom. 1-800 Contacts, Inc. v. United States Federal Trade Commission*, No 18-3848 (2d Cir. Dec. 18, 2018) (counsel for amicus curiae American Intellectual Property Law Association in support of petitioner). The author gratefully acknowledges the editorial contributions of Mary Kathryn Hagge, as well as the cite-checking assistance of Louise Adams, Trevor Rosen, Cynthia Baldwin, Rebecca Hendrix, Caroline Maass, and Steven Verez in preparing his contribution to this Review for publication.

¹ See *Standard Paint Co. v. Trinidad Asphalt Mfg. Co.*, 220 U.S. 446 (1911); *Jacobs v. Beecham*, 221 U.S. 263 (1911); *Baglin v. Cusenier Co.*, 221 U.S. 580 (1911); *Creswill v. Grand Lodge, Knights of Pythias*, 225 U.S. 246 (1911).

the Court's disposition of the cases currently on its docket, it may well surpass its 1911 tally of opinions.

The obvious headliner is *Iancu v. Brunetti*,² in which, following on the heels of *Matal v. Tam*,³ the Court invalidated the prohibition in Section 2(a) of the Lanham Act⁴ on the registration of immoral and scandalous marks as a viewpoint-discriminatory violation of the First Amendment. Nevertheless, because of the likely limited combined effect of *Tam* and *Brunetti* on other prohibitions on registration contained in Section 2,⁵ the Court's impending resolution in *Romag Fasteners, Inc. v. Fossil, Inc.*⁶ of the long-standing circuit split on whether willful misconduct is a prerequisite for accountings of profits under Section 35(a) of the Act⁷ is of far greater consequence to the average litigant under the Act: In contrast to pre-*Tam* and pre-*Brunetti* interpretations of Section 2(a), the current diverging applications of Section 35(a) have created very real opportunities for forum shopping and the possibility of dramatically varying monetary relief on similar facts. Moreover, the same is true of the Court's consideration in *United States Patent and Trademark Office v. Booking.com B.V.*⁸ of a question presented reading "[w]hether the addition by an online business of a generic top-level domain (.com) to an otherwise generic term can create a protectable trademark."⁹ Indeed, even the holding in *Mission Product Holdings, Inc. v. Tempnology, LLC*¹⁰ that the rejection of an executory contract comprising a trademark license by a bankrupt debtor that issued the license does not necessarily terminate the licensee's right to continue using the licensed mark and the Court's review of the vagaries of defensive claim preclusion in *Lucky Brand Dungarees, Inc. v. Marcel Fashions Group*¹¹ could have greater long-term significance than the partial invalidation of Section 2(a).¹²

² 139 S. Ct. 2294 (2019).

³ 137 S. Ct. 1744 (2017).

⁴ 15 U.S.C. § 1052 (2018).

⁵ See generally Theodore H. Davis Jr. & John Welch, *United States Annual Review: The Seventy-First Year of Administration of the Lanham Act of 1946*, 109 TMR 1, 3-4 (2019).

⁶ 139 S. Ct. 2778 (2019) (granting certiorari).

⁷ 15 U.S.C. § 1117(a) (2018).

⁸ No. 19-46, 2019 WL 5850636 (U.S. Nov. 8, 2019) (granting certiorari).

⁹ Petition for Writ of Certiorari, at i, *United States Patent & Trademark Office v. Booking.com B.V.*, No. 19-46 (U.S. July 15, 2019).

¹⁰ 139 S. Ct. 1652 (2019).

¹¹ 139 S. Ct. 2777 (2019).

¹² The fifth trademark-related case on the Court's docket, see *U.S. Patent & Trademark Office v. Booking.com B.V.*, No. 19-46, 2019 WL 5850636 (U.S. Nov. 8, 2019) (granting certiorari), addresses the question of whether an applicant appealing to a district court from an adverse opinion by the Trademark Trial and Appeal Board must reimburse the USPTO's attorneys' fees under Section 21(b)(3) of the Act, 15 U.S.C. § 1071(b)(3) (2018), even if it prevails in the appeal. Based on the Court's disposition of the virtually identical question under Section 145 of the Patent Act, 25 U.S.C. § 145 (2018), in *Peter v.*

Of course, the Supreme Court was not the only tribunal to address the significance of the First Amendment to trademark and unfair competition litigation. On the contrary, the twelve months between the seventy-second and seventh-third anniversaries of the Lanham Act's effective date produced the usual opinions in which defendants successfully asserted claims of free speech in response to challenges to the titles and content of artistic works.¹³ Nevertheless, that was not the only context in which the First Amendment made appearances, for the Fifth Circuit sustained a First Amendment-based challenge to a prohibition under Mississippi law on commercial uses of the word "engineer" by parties not holding engineering licenses from the state;¹⁴ moreover, and rather improbably, a California federal district court invoked the amendment to rebuff an attempt by the federal government to seize three collective membership marks owned by a motorcycle club found guilty of criminal racketeering and conspiracy.¹⁵

Nor was the First Amendment the only provision of the Bill of Rights to come into play in reported opinions.¹⁶ Instead, the Eleventh Circuit addressed and answered a question of first impression for it, namely, whether the Seventh Amendment right to a jury trial extends to the equitable remedy of a prevailing plaintiff's request for an accounting of the defendant's profits; having identified that remedy as an equitable one, the court held it beyond the amendment's reach.¹⁷ Likewise, the Eighth Circuit held that "[t]he 'determination of equitable defenses . . . is a matter for the

Nantkwest, Inc., 140 S. Ct. 365 (2019), the Fourth Circuit's conclusion that Section 21(b)(3) does mandate automatic fee awards almost certainly is defunct. *See Booking.com B.V. v. U.S. Patent & Trademark Office*, 915 F.3d 171, 187-88 (4th Cir.), *as amended* (Feb. 27, 2019), *cert. granted*, No. 19-46, 2019 WL 5850636 (U.S. Nov. 8, 2019). The only open issue with respect to that case therefore appears to be whether the Court will reverse the Fourth Circuit's interpretation of Section 21(b)(3) itself or vacate and remand the matter for the Fourth Circuit to address the question in the first instance.

¹³ *See, e.g.*, *Caiz v. Roberts*, 382 F. Supp. 3d 942, 948-52 (C.D. Cal. 2019) (applying First Amendment to bar challenge to title of musical album and associated tour), *appeal dismissed*, No. 19-55611, 2019 WL 6331647 (9th Cir. Aug. 30, 2019); *Dr. Seuss Enters. v. ComicMix LLC*, 372 F. Supp. 3d 1101, 1126-27 (S.D. Cal. 2019) (referencing court's past grant of defense motion for summary judgment in challenge to content of book).

¹⁴ *See Express Oil Change, L.L.C. v. Miss. Bd. of Licensure for Prof'l Eng'rs & Surveyors*, 916 F.3d 483, 493 (5th Cir. 2019).

¹⁵ *See United States v. Mongol Nation*, 370 F. Supp. 3d 1090, 1114 (C.D. Cal. 2019).

¹⁶ *See, e.g., id.* at 1120 (rejecting proposed forfeiture of collective membership marks as cruel and unusual punishment under the Eighth Amendment).

¹⁷ *See Hard Candy, LLC v. Anastasia Beverly Hills, Inc.*, 921 F.3d 1343, 1358 (11th Cir. 2019) ("[A] claim for an accounting and disgorgement of profits under the Lanham Act is equitable in nature and, therefore, . . . the Seventh Amendment's guarantee of a jury trial does not apply.").

court to decide, not the jury.”¹⁸ The correctness of these holdings, however, did not stop other courts from referring equitable matters to juries.¹⁹

On the distinctiveness front, Booking.com’s successful defense before the Fourth Circuit of a district court finding that its flagship BOOKING.COM mark was descriptive for at least some of the services offered under the mark²⁰ proved something of an outlier, as courts and the Board otherwise found an unusually large number of claimed marks generic. Those included “webuyhouses.com” and “we buy houses,” for referrals and the provision of online information in the field of real estate procurement and various printed materials bearing on real estate topics,²¹ “ordermyoil.com” for the delivery of home heating oil,²² “BAK-12” for mobile aircraft arresting systems,²³ “virtual independent paralegals” for paralegal and litigation support services,²⁴ and “algae wafers” for fish food.²⁵ The Federal Circuit got into the act as well, albeit in an opinion only vacating and remanding a determination by the Board that the word “zero” was not generic for various beverages.²⁶

Courts weighing the functionality or nonfunctionality of claimed trade dresses continued to retreat from the Supreme Court suggestion in *TrafFix Devices, Inc. v. Mktg. Displays, Inc.*²⁷ that

¹⁸ See *Sturgis Motorcycle Rally, Inc. v. Rushmore Photo & Gifts, Inc.*, 908 F.3d 313, 343 (8th Cir. 2018) (quoting *Smith v. World Ins. Co.*, 38 F.3d 1456, 1462 (8th Cir. 1994), *on remand*, 129 U.S.P.Q.2d 1392 (D.S.D. 2019).

¹⁹ See, e.g., *Talent Mobile Dev., Inc. v. Headios Grp.*, 382 F. Supp. 3d 953, 963 (C.D. Cal. 2019) (declining to overturn accounting of profits by jury), *appeal docketed*, No. 19-55258 (9th Cir. Mar. 5, 2019); *De Simone v. VSL Pharm., Inc.*, 395 F. Supp. 3d 617, 636-37 (D. Md. 2019) (same), *appeal docketed sub nom De Simone v. Alfasigma USA, Inc.*, No. 19-1731 (4th Cir. July 12, 2019), *and appeal docketed sub nom. De Simone v. Leadiant Biosciences, Inc.*, No. 19-1762 (4th Cir. July 22, 2019); *Evoqua Water Techs. LLC v. M.W. Watermark, LLC*, 128 U.S.P.Q.2d 1775, 1782 (W.D. Mich. 2018) (same); *Ill. Tool Works Inc. v. Rust-Oleum Corp.*, 346 F. Supp. 3d 951, 958-59 (S.D. Tex. 2018) (referencing earlier referral of accounting to jury), *appeal docketed*, No. 19-20210 (5th Cir. April 4, 2019).

²⁰ See *Booking.com B.V. v. United States Patent & Trademark Office*, 915 F.3d 171, 187 (4th Cir.), *as amended* (Feb. 27, 2019), *cert. granted*, No. 19-46, 2019 WL 5850636 (U.S. Nov. 11, 2019).

²¹ See *Express Homebuyers USA, LLC v. WBH Mktg. Inc.*, 323 F. Supp. 3d 784, 793 (E.D. Va. 2018), *reconsideration denied*, No. 1:17-CV-736, 2018 WL 6616675 (E.D. Va. Aug. 29, 2018), *appeal docketed*, No. 18-2149 (4th Cir. Oct. 2, 2018).

²² See *United Oil Heat, Inc. v. M.J. Meehan Excavating, Inc.*, 129 N.E.3d 856, 858 (Mass. Ct. App. 2019).

²³ See *Engineered Arresting Sys. Corp. v. Atech, Inc.*, 356 F. Supp. 3d 1323, 1342 (N.D. Ala. 2018).

²⁴ See *In re Virtual Independent Paralegals, LLC*, 2019 U.S.P.Q.2d 111512, at *7 (T.T.A.B. 2019).

²⁵ See *In re Hikari Sales USA, Inc.*, 2019 U.S.P.Q.2d 111514, at *13 (T.T.A.B. 2019).

²⁶ See *Royal Crown Co. v. Coca-Cola Co.*, 892 F.3d 1358, 1368 (Fed. Cir. 2018).

²⁷ 532 U.S. 23 (2001).

evidence of alternative designs is entitled to limited weight.²⁸ For example, the Federal Circuit affirmed a finding of nonfunctionality for a shoe design based in part on the plaintiff's proffer of "numerous commercial alternatives" in the marketplace.²⁹ The Seventh Circuit similarly affirmed a finding of nonfunctionality for the configuration of a coffee press for the same reason.³⁰ And a South Carolina federal district court found as a matter of law that the color orange was nonfunctional when used in connection with safe access and loading units based on the plaintiff's showing that "many other competitors use metallic gray or other colors, such as yellow."³¹

Resolutions of the likelihood of confusion between particular marks produced several opinions of note.³² One of the most notable came from a Virginia federal district court entertaining an appeal from an opposition before the Trademark Trial and Appeal Board in which the court refused to apply the Fourth Circuit's standard multifactor test for likely confusion, holding instead that "in a registration opposition proceeding before the TTAB, the likelihood of confusion analysis considers only 'the mark as shown in the application and as used on the goods described in the application . . . not the mark as actually used.'"³³ Another emanated from the Federal Circuit, which opened the door wider than it has in the past to the use in the registration context of sworn testimony of marks' coexistence without actual confusion.³⁴ And the District of Columbia Circuit, which for decades has failed to provide guidance on the issue to the federal district courts answering to it, finally—*finally*—appeared to endorse a set of factors governing the likelihood-of-confusion inquiry.³⁵

Two final issues, both registration-related, merit comment. First, although the Board displayed its usual hostility to claims of the fraudulent procurement of registrations,³⁶ and most courts in

²⁸ *Id.* at 33 ("Where the design is functional . . . there is no need to proceed further to consider if there is a competitive necessity for the feature.").

²⁹ *See* *Converse, Inc. v. Int'l Trade Comm'n*, 909 F.2d 1110, 1124 (Fed. Cir. 2018).

³⁰ *See* *Bodum USA, Inc. v. A Top New Casting Inc.*, 927 F.3d 486, 495 (7th Cir. 2019).

³¹ *See* *SafeRack, LLC v. Bullard Co.*, 350 F. Supp. 3d 438, 453 (D.S.C. 2018), *report and recommendation adopted*, No. 2:17-cv-1613-RMG, 2019 WL 460699 (D.S.C. Feb. 5, 2019).

³² *See* *Springboards to Educ., Inc. v. Hous. Indep. Sch. Dist.*, 912 F.3d 805, 814-16 (5th Cir. 2019) (reaching sua sponte finding as a matter of law that confusion unlikely between parties' marks), *as revised* (Jan. 29, 2019), *and as revised* (Feb. 14, 2019).

³³ *Combe Inc. v. Dr. August Wolff GmbH & Co. KG Arzneimittel*, 382 F. Supp. 3d 429, 444 (E.D. Va. 2019) (quoting *B & B Hardware, Inc. v. Hargis Indus.*, 135 S. Ct. 1293, 1307 (2015)), *appeal docketed*, No. 19-1674 (4th Cir. June 24, 2019).

³⁴ *Se In re Guild Mortg. Co.*, 912 F.3d 1376, 1381 (Fed. Cir. 2019).

³⁵ *See* *Am. Soc'y for Testing & Materials v. Public.Resource.Org, Inc.*, 896 F.3d 437, 456 (D.C. Cir. 2018).

³⁶ *See* *Australian Therapeutic Supplies Pty. Ltd. v. Naked TM, LLC*, 129 U.S.P.Q.2d 1027, 1034 (T.T.A.B. 2018) (dismissing fraudulent procurement cause of action for want of standing).

the regional circuits followed suit,³⁷ the same was not true of all courts. Rather improbably, this took the form of opinions crediting claims that registrants under Section 1(a)³⁸ had misstated the dates of first use of their marks,³⁹ despite the general rule that such misstatements are ordinarily immaterial to the issuance of registrations if the actual dates of first use predated the filing dates of the underlying applications.⁴⁰ Perhaps more ominously, the Second Circuit backslid from the strict test for fraud applied in such opinions as *In re Bose Corp.*⁴¹ in favor of one resembling that for negligence.⁴² As the Second Circuit saw the matter:

Our precedents require a party alleging fraudulent registration to prove by clear and convincing evidence:

1. A false representation regarding a material fact.
2. The person making the representation knew *or should have known* that the representation was false (“scienter”).
3. An intention to induce the listener to act or refrain from acting in reliance on the misrepresentation.
4. Reasonable reliance on the misrepresentation.
5. Damage proximately resulting from such reliance.⁴³

The court’s adoption of a known-or-should-have-known standard came after it had disavowed that standard in its last reported opinion to address the issue.⁴⁴

³⁷ See *OTR Wheel Eng’g, Inc. v. W. Worldwide Servs., Inc.*, 897 F.3d 1008, 1019-21 (9th Cir. 2018) (rejecting claim of fraudulent procurement as a matter of law); *SafeRack, LLC v. Bullard Co.*, 350 F. Supp. 3d 438, 455 (D.S.C. 2018) (same), *report and recommendation adopted*, No. 2:17-cv-1613-RMG, 2019 WL 460699 (D.S.C. Feb. 5, 2019); *Deckers Outdoor Corp. v. Australian Leather Pty. Ltd.*, 340 F. Supp. 3d 706, 717-18 (N.D. Ill. 2018) (same).

³⁸ 15 U.S.C. § 1051(a) (2018).

³⁹ See *Excelled Sheepskin & Leather Coat Corp. v. Or. Brewing Co.*, 897 F.3d 413, 422-23 (2d Cir. 2018) (vacating entry of summary judgment); *AECOM Energy & Constr., Inc. v. Ripley*, 348 F. Supp. 3d 1038, 1060 (C.D. Cal. 2018) (reaching finding of fraudulent procurement as a matter of law), *reconsideration denied*, No. CV 17-5398-RSWL-SSx, 2019 WL 2610953 (C.D. Cal. Apr. 24, 2019), *appeal docketed*, No. 19-55588 (9th Cir. May 2, 2019).

⁴⁰ See, e.g., *Teeter-Totter, LLC v. Palm Bay Int’l, Inc.*, 344 F. Supp. 3d 1100, 1110 (N.D. Cal. 2018) (granting summary judgment to registrant); *Mayson-Dixon Strategic Consulting, LLC v. Mason-Dixon Polling & Strategic Consulting, Inc.*, 324 F. Supp. 3d 569, 576 (D. Md. 2018) (rejecting claim of fraudulent procurement while granting motion for preliminary injunction).

⁴¹ 580 F.3d 1240 (Fed. Cir. 2009).

⁴² See *Excelled Sheepskin & Leather Coat Corp. v. Or. Brewing Co.*, 897 F.3d 413 (2d Cir. 2018).

⁴³ *Id.* at 421-22 (emphasis added).

⁴⁴ See *MPC Franchise, LLC v. Tarantino*, 826 F.3d 653, 659 (2d Cir. 2016) (“[A]ny suggestion in [yet another earlier opinion] that the scienter element is satisfied when a plaintiff shows merely that an applicant ‘should have known’ the falsity of a representation is dicta.”).

Second, although wholly extrastatutory in nature, the failure-to-function-as-a-mark ground for the refusal of applications has made increasing appearances in the Board's case law in recent years, and the seventy-first year of administration of the Lanham Act was no exception. Thus, the Board affirmed an *ex parte* refusal to register the claimed mark "I love you" for jewelry,⁴⁵ and it took the same step where the claimed "investing in American jobs" mark for "promoting public awareness [of] goods made or assembled by American workers was concerned."⁴⁶ The claimed "#magicnumber" mark for shirts suffered the same fate,⁴⁷ as did the claimed "unlimited carryover" mark for telecommunication services.⁴⁸ The message of these findings seems clear: An applied-for mark's perceived failure to function as one has taken its place as an all-purpose ground for the refusal of an application, regardless of the absence of underlying statutory authority for it.

⁴⁵ See *In re Peace Love World Live, LLC*, 127 U.S.P.Q.2d 1400, 1404-05 (T.T.A.B. 2018).

⁴⁶ See *In re Wal-Mart Stores, Inc.*, 129 U.S.P.Q.2d 1148, 1160 (T.T.A.B. 2019).

⁴⁷ See *In re DePorter*, 129 U.S.P.Q.2d 1298, 1304-07 (T.T.A.B. 2019).

⁴⁸ See *In re TracFone Wireless, Inc.*, 2019 U.S.P.Q.2d 222983, at *2-3 (T.T.A.B. 2019).

PART I. EX PARTE CASES

*By John L. Welch**

A. United States Supreme Court

1. Section 2(a) Scandalous or Immoral

Iancu v. Brunetti

Two years ago in *Matal v. Tam*,¹ the United States Supreme Court held invalid the disparagement provision of Section 2(a) of the Trademark Act,² finding it facially unconstitutional because it discriminated on the basis of viewpoint and therefore violated the Free Speech Clause of the First Amendment.³ Here, the Court ruled that the Section 2(a) provision that bars registration of a mark that is immoral or scandalous likewise infringes the First Amendment because “[i]t too disfavors certain ideas.”⁴

Erik Brunetti sought registration of the mark FUCT for athletic apparel. The United States Patent and Trademark Office (“USPTO”) refused registration under the “immoral . . . or scandalous” portion of Section 2(a), and the Trademark Trial and Appeal Board (“TTAB”) affirmed the refusal, finding that FUCT is vulgar and therefore scandalous.⁵

The United States Court of Appeals for the Federal Circuit (“CAFC”) had ruled that substantial evidence supported the Board’s findings and that the Board did not err in concluding that FUCT comprises immoral or scandalous matter.⁶ The CAFC then considered the constitutionality of this Section 2(a) bar, an issue

* Author of Parts I and II of this Review. Counsel to Wolf, Greenfield & Sacks, P.C., Boston, Massachusetts. The author wishes to thank Kira-Khanh McCarthy for her invaluable assistance in preparing the manuscript. In the interest of full disclosure, the author notes his participation and that of Wolf Greenfield as counsel for the defendant in *Spangler Candy Co. v. Tootsie Roll Industries*, 372 F. Supp. 3d 588 (N.D. Ohio), referenced in this Review.

¹ 582 U.S. ____, 137 S. Ct. 1744, 122 U.S.P.Q.2d 1757 (2017) (involving the mark THE SLANTS for “entertainment in the nature of live performances by a musical band”).

² Section 2(a) of the Lanham Act, 15 U.S.C. § 1052(a) (2012), in pertinent part, bars registration of a mark that “[c]onsists of or comprises immoral, deceptive, or scandalous matter; or matter which may disparage . . . persons, living or dead, institutions, beliefs, or national symbols, or bring them into contempt, or disrepute”

³ The First Amendment to the United States Constitution, U.S. Const. amend I, states in pertinent part: “Congress shall make no law . . . abridging the freedom of speech, or of the press”

⁴ *Iancu v. Brunetti*, 588 U.S. ____, 139 S. Ct. 2294, 2297, 2019 U.S.P.Q.2d 232402 at *2 (2019). Justice Kagan delivered the opinion of the Court, in which Justices Thomas, Ginsburg, Alito, Gorsuch, and Kavanaugh joined. Chief Justice Roberts and Justice Breyer filed opinions concurring in part and dissenting in part. Justice Sotomayor filed an opinion concurring in part and dissenting in part, in which Justice Breyer joined.

⁵ *In re Brunetti*, Serial No. 85310960 (T.T.A.B. August 1, 2014).

⁶ *In re Brunetti*, 877 F.3d 1330, 125 U.S.P.Q.2d 1072, 1076 (Fed. Cir. 2017).

that was beyond the TTAB's jurisdiction, and it concluded that the immoral or scandalous provision is unconstitutional because it restricts free speech in violation of the First Amendment.⁷ The Supreme Court affirmed the judgment of the CAFC.

The Court observed that in *Matal v. Tam*, “[t]he eight-Justice Court divided evenly between two opinions and could not agree on the overall framework for deciding the case.”⁸ However, all the Justices agreed on two propositions: “First, if a trademark registration bar is viewpoint-based, it is unconstitutional. And second, the disparagement bar was viewpoint-based.”⁹ And so, in *Matal v. Tam*, “[t]he Justices . . . found common ground in a core postulate of free speech law: The government may not discriminate against speech based on the ideas or opinions it conveys.”¹⁰

In *Iancu v. Brunetti*, the government conceded that if the immoral or scandalous provision discriminates based on viewpoint, it is unconstitutional. The question then was whether this provision is viewpoint-neutral or viewpoint-based. The Court concluded that it is viewpoint-based.¹¹

After reviewing dictionary definitions of “immoral”¹² and “scandalous,”¹³ the Court described the effect of the provision as follows:

So the Lanham Act allows registration of marks when their messages accord with, but not when their messages defy, society's sense of decency or propriety. Put the pair of overlapping terms together and the statute, on its face, distinguishes between two opposed sets of ideas: those aligned with conventional moral standards and those hostile to them; those inducing societal nods of approval and those provoking offense and condemnation. The statute favors the former, and disfavors the latter.¹⁴

⁷ *Id.* at 1357.

⁸ *Brunetti*, 139 S. Ct. at 2298, 2019 U.S.P.Q.2d 232402 at *3. “In particular, no majority emerged to resolve whether a Lanham Act bar is a condition on a government benefit or a simple restriction on speech.” *Id.*

⁹ *Id.* at 2296.

¹⁰ *Id.* at 2299.

¹¹ *Id.*

¹² *Id.* According to Webster's New International Dictionary 1246 (2d ed. 1949), material is “immoral” when it is “inconsistent with rectitude, purity, or good morals”; “wicked”; or “vicious” or when it is “opposed to or violating morality”; or “morally evil.” Shorter Oxford English Dictionary 961 (3d ed. 1947).

¹³ *Id.* at 2299-2300. The Court asked when such material is “scandalous.” Webster's New International Dictionary 2229 (2d ed. 1949) answers: when it “giv[es] offense to the conscience or moral feelings”; “excite[s] reprobation”; or “call[s] out condemnation.” Or, per Funk & Wagnalls New Standard Dictionary 2186 (1944), when it is “shocking to the sense of truth, decency, or propriety”; “disgraceful”; “offensive”; or “disreputable.”

¹⁴ *Id.* at 2300.

Furthermore, the Court found that the “facial viewpoint bias” in the law, as applied by the USPTO, results in viewpoint-discriminatory refusals to register. The USPTO has rejected marks that communicate immoral or scandalous viewpoints, while approving marks that express more acceptable views on, for example, the topics of drug use, religion, and terrorism.¹⁵

The government urged that the statute is “susceptible of” a narrow construction that would eliminate the viewpoint bias, by limiting the statutory bar to “marks that are offensive [or] shocking to a substantial segment of the public because of their *mode* of expression, independent of any view that they may express.”¹⁶ The government proposed restricting the scope of the provision to marks that are “vulgar,” meaning “lewd,” “sexually explicit or profane,”¹⁷ but the Court rejected that argument because the statute “says something markedly different.”¹⁸ “To cut the statute off where the Government urges is not to interpret the statute Congress enacted, but to fashion a new one.”¹⁹

Chief Justice Roberts and Justices Breyer and Sotomayor opined that, although the “immoral” portion of the provision was unconstitutional, the “scandalous” portion could survive if interpreted narrowly. Both the Chief Justice and Justice Breyer agreed with Justice Sotomayor that the term “scandalous” need not be construed to reach marks that offend because of the ideas they convey. Instead, it could be construed to bar only marks that offend because of their mode of expression: i.e., marks that are obscene, vulgar, or profane.²⁰ Justice Alito, who joined in the majority opinion, suggested that Congress could enact a provision having carefully focused language prohibiting registration of marks containing vulgar terms that play no real part in the expression of ideas.²¹

¹⁵ *Id.* For instance, the USPTO rejected marks conveying approval of drug use (YOU CAN’T SPELL HEALTHCARE WITHOUT THC for pain-relief medication, MARIJUANA COLA, and KO KANE for beverages) because it is scandalous to “inappropriately glamoriz[e] drug abuse.” See Serial Nos. 85038867, 77833964, and 77671304. But, it registered marks with such sayings as D.A.R.E. TO RESIST DRUGS AND VIOLENCE and SAY NO TO DRUGS—REALITY IS THE BEST TRIP IN LIFE. See Reg. Nos. 2975163 and 2966019.

¹⁶ *Id.* at 2301.

¹⁷ *Id.*

¹⁸ *Id.*

¹⁹ *Id.* at 2302.

²⁰ *Id.* at 2318.

²¹ *Id.* at 2303.

B. United States Court of Appeals for the Federal Circuit

1. Section 2(d) Likelihood of Confusion

In re Detroit Athletic Co.

In an opinion that serves as a primer on much of the law of Section 2(d) as applied by the TTAB, the CAFC upheld the Board's affirmance of a refusal to register the mark DETROIT ATHLETIC CO. for sports apparel retail services [ATHLETIC CO. disclaimed] in view of the registered mark DETROIT ATHLETIC CLUB for various clothing items [ATHLETIC CLUB disclaimed], both marks being in standard character form.²²

The Board concluded that "because the marks are similar, the goods and services are related, and the channels of trade and consumers overlap,"²³ consumers are likely to be confused by the marks. The CAFC ruled that the Board's conclusion was supported by substantial evidence.

The court agreed that the marks are identical in structure and have a similar appearance, sound, connotation, and commercial impression. "These similarities go a long way toward causing confusion among consumers."²⁴ The fact that the marks begin with the same two words is "particularly significant because consumers typically notice those words first."²⁵ The "lead words are their dominant portion and are likely to make the greatest impression on consumers."²⁶ This factor "weighs heavily" in the *du Pont* analysis.²⁷

Contrary to appellant's argument, the Board did not ignore the words "CO." and "CLUB" but rather considered the marks in their entirety, and it did not err in focusing on the dominant portions of the marks.

The goods in the cited registration are general in nature and cover all types of clothing (including athletic uniforms and sweatshirts). The applicant's services relate to sports apparel and the clothing items sold by the applicant comprise a subset of the goods of the registration. Thus, the involved goods and services "substantially overlap."²⁸

The evidence showed that several third-party apparel retailers sell clothing bearing their own marks as well as apparel bearing the names and logos of sports teams. This suggests that "consumers are

²² *In re Detroit Athletic Co.*, 903 F.3d 1297, 128 U.S.P.Q.2d 1047 (Fed. Cir. 2018).

²³ *Id.* at 1309-10.

²⁴ *Id.* at 1303.

²⁵ *Id.*

²⁶ *Id.*

²⁷ *Id. In re E.I. du Pont de Nemours & Co.*, 476 F.2d 1357, 177 U.S.P.Q. 563 (C.C.P.A. 1973). The *du Pont* opinion sets forth the principal factors that "must be considered" in determining likelihood of confusion.

²⁸ *Id.* at 1306.

accustomed to seeing a single mark associated with a source that sells both its own branded clothing (as does the Detroit Athletic Club) as well as sports-teams-branded clothing (as does DACo [sic]).”²⁹

The applicant maintained that consumers would have little trouble distinguishing between its clothing store and registrant’s private social club. However, the court deemed that argument to be out-of-bounds because the focus must be “on the goods and services *described in the application and registration*, and *not* on real-world conditions.”³⁰

Because the registration includes no restrictions on channels of trade or classes of consumers, the Board did not err in finding that the registrant’s trade channels are broad enough to encompass the applicant’s trade channels. It is irrelevant if, as the applicant maintained, the registrant sells its clothing only in its gift shop to club members. The *du Pont* analysis must consider the channels specified (or not) in the application and registration, not the parties’ actual channels of trade. Moreover, “the owner of an unrestricted registration is entitled to change its current trade channels at any time,”³¹ and it cannot be assumed that the registrant will never sell clothing online or through third-party distributors.

The applicant pointed to the lack of evidence of actual confusion, but the court observed that the relevant test is *likelihood* of confusion, not *actual* confusion. Evidence that consumers are not confused³² is relevant but not dispositive, particularly in an *ex parte* context.³³ Moreover, the applicant’s evidence—a brief consumer affidavit and several Internet search results and online reviews—did not establish a lack of consumer confusion in commercially meaningful contexts. Substantial evidence therefore supported the Board’s dismissal of the applicant’s evidence as non-probative.

²⁹ *Id.*

³⁰ *Id.* at 1307. See *In re i.am.symbolic, llc*, 866 F.3d 1315, 123 U.S.P.Q.2d 1744, 1749 (Fed. Cir. 2017) (“In reviewing the second factor, ‘we consider the applicant’s goods as set forth in its application, and the [registrant’s] goods as set forth in its registration.’” (quoting *M2 Software, Inc. v. M2 Communs., Inc.*, 450 F.3d 1378, 78 U.S.P.Q.2d 1944, 1947 (Fed. Cir. 2006))).

³¹ *Id.* at 1308.

³² *Id.* at 1309. The applicant’s evidence purporting to show a lack of actual confusion included an affidavit of a long-time customer attesting to his history of purchasing goods from the applicant, Internet search results, and online customer reviews for each company.

³³ *Id.* See *In re Majestic Distilling Co.*, 315 F.3d 1311, 65 U.S.P.Q.2d 1201, 1205 (Fed. Cir. 2003) (“The lack of evidence of actual confusion carries little weight, *J. C. Hall Co. v. Hallmark Cards, Inc.*, 340 F.2d 960, 144 U.S.P.Q. 435, 438 (C.C.P.A. 1965), especially in an *ex parte* context.”) (“The ultimate consideration, however, is likelihood of confusion. Absence of proof of actual confusion is of minor relevancy in the resolution of the issue.” *J.C. Hall Co.*, 144 U.S.P.Q. at 438).

The CAFC concluded that the Board appropriately balanced the relevant *du Pont* factors. The Board was not required to consider every factor, but rather may focus on dispositive factors.³⁴ Nor was the Board required to address each item of evidence offered by the applicant as to registrant’s actual services, since “it is the scope of the club’s registration that is relevant in this context, not its actual practices.”³⁵

In re Guild Mortgage Co.

The TTAB did not fare so well in the eyes of the CAFC in this Section 2(d) appeal. The court vacated the Board’s decision that had upheld a refusal to register the mark GUILD MORTGAGE COMPANY & Design for “mortgage banking services, namely, origination, acquisition, servicing, securitization and brokerage of mortgage loans” [MORTGAGE COMPANY disclaimed] in view of the registered mark GUILD INVESTMENT MANAGEMENT for “investment advisory services” [INVESTMENT MANAGEMENT disclaimed]. The appellate court concluded that the Board had failed to consider pertinent evidence and arguments under the eighth *du Pont* factor, and so it remanded the case for reconsideration in light of all the evidence.³⁶

The CAFC pointed out that “[i]n every case turning on likelihood of confusion, it is the duty of the examiner, the board and this court to find, upon consideration of *all* the evidence, whether or not confusion appears likely.”³⁷ “In discharging this duty, the thirteen *du Pont* factors ‘must be considered’ ‘when [they] are of record.’”³⁸

Du Pont factor 8 requires consideration of “the length of time during and conditions under which there has been concurrent use without evidence of actual confusion.”³⁹ Guild argued that it has co-existed with the registrant for more than forty years without actual confusion. Its President and CEO attested that Guild has never received any communications from third parties regarding any confusion, nor has it received any charge of infringement from the registrant.

³⁴ *Id.* at 1310. See *Citigroup Inc. v. Capital City Bank Grp., Inc.*, 637 F.3d 1344, 98 U.S.P.Q.2d 1253, 1260 (Fed. Cir. 2011) (“The T.T.A.B. is not required to discuss every *du Pont* factor and may find a single factor dispositive.”); *Herbko Int’l, Inc. v. Kappa Books, Inc.*, 308 F.3d 1156, 64 U.S.P.Q.2d 1375, 1380 (Fed. Cir. 2002) (noting that the likelihood of confusion analysis may focus “on dispositive factors, such as similarity of the marks and relatedness of the goods” (internal quotation marks omitted)).

³⁵ *Id.*

³⁶ *In re Guild Mortg. Co.*, 912 F.3d 1376, 129 U.S.P.Q.2d 1160 (Fed. Cir. 2019).

³⁷ *Id.* at 1162, quoting *du Pont* 177 U.S.P.Q. at 568.

³⁸ *Id.*, quoting *In re Dixie Rests., Inc.*, 105 F.3d 1405, 41 U.S.P.Q.2d 1531, 1533 (Fed. Cir. 1997).

³⁹ *Du Pont* 117 U.S.P.Q. at 567.

The Board's opinion provided no indication that it considered the eighth *du Pont* factor or the evidence and argument directed thereto.

In this case, although Guild did not submit declarations from the owner of the registered mark or other parties testifying as to the absence of actual confusion, Guild nonetheless presented evidence of concurrent use of the two marks for a particularly long period of time—over 40 years—in which the two businesses operated in the same geographic market—southern California—without any evidence of actual confusion. Further, the Board has found that Guild's and Registrant's services are similar and move in the same channels of trade, which is relevant when assessing whether the absence of actual confusion is indicative of the likelihood of confusion. The Board erred in its analysis by failing to consider this evidence and argument as to factor 8. Because this evidence weighs in favor of no likelihood of confusion, we do not deem the Board's error harmless.⁴⁰

The CAFC made “no assessment as to the evidentiary weight that should be given to Guild's CEO's declaration.”⁴¹ The Board was directed to “reconsider its likelihood of confusion determination in the first instance in light of all the evidence.”⁴²

2. Genericness

Royal Crown Co. v. Coca-Cola Co.

Vacating the TTAB's May 2016 decision,⁴³ the CAFC ruled that the Board had committed several errors when finding that Opposers Royal Crown and Dr. Pepper/Seven-Up failed to prove that the term “ZERO” is generic for soft drinks, sports drinks, and energy drinks. The Board had also found that Applicant Coca-Cola had established acquired distinctiveness in the term “ZERO” for soft drinks and sports drinks. The appellate court, however, concluded that the Board “erred in its legal framing” of the genericness issue and, as to acquired distinctiveness, erred in failing to assess the level of descriptiveness of the term “ZERO.”⁴⁴

⁴⁰ *Guild Mortg.*, 129 U.S.P.Q.2d at 1163-64.

⁴¹ *Id.* at 1164.

⁴² *Id.*

⁴³ *Royal Crown Co. v. Coca-Cola Co.*, Oppositions No. 91178927 et al. (T.T.A.B. May 23, 2016).

⁴⁴ *Royal Crown Co. v. Coca-Cola Co.*, 892 F.3d 1358, 127 U.S.P.Q.2d 1041 (Fed. Cir. 2018). On May 3, 2019, the Board granted Coca-Cola's motion to amend its 16 opposed applications to add a disclaimer of the word “ZERO”; thus Coca-Cola avoided a finding of genericness. 187 TTABVUE 1. The Board then dismissed the oppositions as moot. *Id.* at 2.

The opposers asserted that ZERO is either generic for, or merely descriptive of, Coca-Cola's beverages, and therefore that ZERO must be disclaimed (including, for example, COCA-COLA ZERO).

Genericness: The court ruled that the Board "asked the wrong question"⁴⁵ in determining the genericness of ZERO: "[T]he Board failed to consider that 'a term can be generic for a genus of goods or services if the relevant public . . . understands the term to refer to a *key aspect* of that genus.'"⁴⁶ In *In re Cordua*, the CAFC also pointed out that "the test is not only whether the relevant public would itself *use* the term to describe the genus, but also whether the relevant public would *understand* the term to be generic."⁴⁷ Moreover, the court observed, "a term is generic if the relevant public understands the term to refer to *part of the claimed genus of goods or services*, even if the public does not understand the term to refer to the broad genus as a whole."⁴⁸

In *In re Cordua*, we found that the term "churrasco" was generic, even for use in connection with a broad class of restaurant services, because the key public would understand the term to be referring to a specialty dish—a sub-aspect of restaurant services. *Id.* at 604. We made clear that "[t]here is no logical reason to treat differently a term that is generic of a category or class of products where some but not all of the goods identified in an application fall within that category." *Id.* at 605 (quoting *In re Analog Devices, Inc.*, 1988 WL 252496, at *3 (T.T.A.B. Mar. 21, 1988)). We pointed out, for instance, that the term "pizzeria" would be generic for restaurant services, even though the public does not understand the term to refer to the broad class of restaurants as a whole; the public need only understand that the term refers to "a particular sub-group or type of restaurant rather than to all restaurants." *Id.*⁴⁹

The court explained that if the public understands ZERO, when used with a designated beverage name, to refer to a sub-group or type of beverage that carries specific characteristics, then the term is generic. The Board "failed to consider whether [consumers] would consider the term ZERO to be generic for a subcategory of the claimed genus of beverages—i.e., the subcategory of the claimed

⁴⁵ *Id.* at 1046.

⁴⁶ *Id.*, quoting *In re Cordua Rests., Inc.*, 823 F.3d 594, 118 U.S.P.Q.2d 1632, 1637 (Fed. Cir. 2016) (emphasis added).

⁴⁷ *Cordua Rests.*, 118 U.S.P.Q.2d at 603 (alteration in original) (quoting *In re 1800Mattress.com IP, LLC*, 586 F.3d 1359, 92 U.S.P.Q.2d 1682, 1685 (Fed. Cir. 2009)).

⁴⁸ *Id.* at 605 (emphasis added).

⁴⁹ *Royal Crown Co.*, 127 U.S.P.Q.2d at 1046-47.

beverages encompassing the specialty beverage categories of drinks with few or no calories or few or no carbohydrates.”⁵⁰

The court instructed the Board to consider on remand whether ZERO is generic because it “refers to at key aspect of at least a subgroup or type of the claimed beverage goods.”⁵¹

Descriptiveness: The Board also erred by deciding the issue of acquired distinctiveness without first properly determining the extent of the opposers’ burden of proof. The opposers asserted that ZERO was so highly descriptive that “the Board’s assessment of [Applicant’s] evidence of acquired distinctiveness must be exacting.”⁵²

The CAFC has long held that an applicant’s burden of proving acquired distinctiveness increases with the level of descriptiveness.⁵³ The Board, however, did not make any finding as to the degree of descriptiveness of ZERO and thus did not view the evidence “through an exacting lens.”⁵⁴

On remand, the Board “must make an express finding regarding the degree of the mark’s [sic] descriptiveness on the scale ranging from generic to merely descriptive, and it must explain how its assessment of the evidentiary record reflects that finding.”⁵⁵

Evidentiary Issues: The CAFC noted several concerns with the treatment of the relevant evidence. First, the opposers were not required, despite the Board’s intimations otherwise, to provide direct evidence of consumer perception to support their genericness claim. Evidence regarding genericness may be obtained from any competent source, including consumer surveys, dictionaries, newspapers, and other publications.

Second, the Board was wrong in its position that the ubiquity of Coke’s ZERO product and its massive sales figures helped to outweigh the opposers’ evidence of genericness. Generic terms “cannot be rescued by proof of distinctiveness or secondary meaning no matter how voluminous the proffered evidence may be.”⁵⁶ This

⁵⁰ *Id.* at 1047.

⁵¹ *Id.*

⁵² *Id.*

⁵³ *Id.*, citing *In re Steelbuilding.com*, 415 F.3d 1293, 75 U.S.P.Q.2d 1420, 1424 (Fed. Cir. 2005); see also *In re Boston Beer Co.*, 198 F.3d 1370, 53 U.S.P.Q.2d 1056, 1058 (Fed. Cir. 1999).

⁵⁴ *Id.* at 1048.

⁵⁵ *Id.*

⁵⁶ *Id.*, quoting *In re Northland Aluminum Prods.*, 777 F.2d 1556, 227 U.S.P.Q. 961, 962 (Fed. Cir. 1985) (alteration in original) (quoting Examining Attorney); see also *Weiss Noodle Co. v. Golden Cracknel & Specialty Co.*, 290 F.2d 845, 129 U.S.P.Q.2d 411, 414 (C.C.P.A. 1961) (“The examiner erred in accepting the showing of ‘distinctiveness’ in granting the registration because no matter what the market situation may have been as to indication of origin or secondary meaning, the common descriptive name of the product cannot become a trademark owned exclusively by one vendor.”)

type of evidence may be relevant to the issue of acquired distinctiveness, but not to genericness.

Finally, the Board noted that Coke's survey evidence was of questionable probative value, since the survey was conducted more than five years before the testimony periods in these proceedings and thus could not reflect contemporary public perception, particularly in light of the evidence of third-party use in the intervening years.⁵⁷

Because the Board applied the incorrect legal standard in assessing whether [Coca-Cola's] ZERO marks are generic, and did not adequately consider [the opposers'] evidence with respect thereto, we vacate the Board's dismissal of Royal Crown [et al.]'s oppositions on that ground. We also vacate the Board's acquired distinctiveness determination to allow it, in the first instance, to assess the nature of [Coca-Cola's] burden on that point and to explain how the evidence presented meets that precise burden.⁵⁸

3. Specimen of Use

In re Siny Corp.

The CAFC upheld the decision of a divided TTAB panel that affirmed a refusal to register the mark CASALANA for "knit pile fabric made with wool for use as a textile in the manufacture of outerwear, gloves, apparel, and accessories," on the ground that Applicant Siny failed to submit an acceptable specimen of use. Siny contended that its specimen, a webpage printout, qualified as a display associated with the goods, but the panel majority disagreed.⁵⁹

The Lanham Act provides for registration of a mark based on use of the mark in commerce.⁶⁰ A mark is deemed in use in commerce on goods when, inter alia, "it is placed in any manner on the goods or their containers *or the displays associated therewith* or on the tags or labels affixed thereto."⁶¹

⁵⁷ *Id.* at 1049.

⁵⁸ *Id.*

⁵⁹ *In re Siny Corp.*, 920 F.3d 1331, 2019 U.S.P.Q.2d 11362 (Fed. Cir. 2019). At the request of the USPTO, the court re-designated its opinion as precedential. The USPTO's letter to the CAFC stated that:

Reissuing *Siny* as precedential will not change any future decision by the USPTO because *Siny* is consistent with the USPTO's interpretation of the statutory language and past practice with respect to "displays associated" with goods. Rather, it will provide certainty to future applicants regarding what satisfies the statutory requirements for "displays associated" with goods.

Document No. 46 filed with the CAFC on March 14, 2019, in Case No. 18-1077.

⁶⁰ 15 U.S.C. § 1051(a) (2012).

⁶¹ *Id.* at § 1127 (emphasis added).

Siny pointed out that its specimen included a means to purchase the goods: namely, the phrase “For sales information:” followed by a phone number and email address. The USPTO examining attorney rejected that argument, maintaining that the phrase was by itself insufficient to allow consumers to make a purchase. Rather, the phrase indicated only how consumers could obtain more information necessary to make a purchase. The examining attorney noted the absence of ordering information, such as minimum quantities, cost, payment options, and shipping information.

On appeal to the Board, Siny contended that its webpage specimen constituted a “display associated with the goods.” The Board “appreciated Siny’s contention that because the goods were industrial materials for use by customers in manufacture, the ultimate sales transaction may have to involve some assistance from Siny’s sales personnel.”⁶² Nonetheless, it found that although some details are left to be worked out by telephone, virtually all important aspects of the transaction must be derived from information not available on the web page. Therefore, the Board found that the webpage is not a point of sale display.

The CAFC observed that whether a specimen qualifies as a display associated with the goods is a factual question, subject to review under the “substantial evidence” standard.⁶³

[The Board] noted the absence of information it considered to be essential to a purchasing decision, such as a price or range of prices for the goods, the minimum quantities one may order, accepted methods of payment, or how the goods would be shipped. . . . The Board also considered the “For sales information:” text and phone number contact. It assumed that the phone number would connect a prospective customer to sales personnel, but it found that “if virtually all important aspects of the transaction must be determined from information extraneous to the web page, then the web page is not a point of sale”⁶⁴

On this appeal, Siny mainly argued that the Board applied “overly rigid requirements” in determining that Siny’s website specimen did not qualify as a display associated with the goods.⁶⁵ Siny correctly observed that the CAFC has cautioned against bright-

⁶² *Siny Corp.*, 2019 U.S.P.Q.2d 11362, at *3.

⁶³ *Id.* at *5. *See, e.g., Royal Crown Co.*, 127 U.S.P.Q.2d at 1044.

⁶⁴ *Id.* at *7. *See In re U.S. Tsubaki, Inc.*, 109 U.S.P.Q.2d 2002, 2005 (T.T.A.B. 2014) (“A simple invitation to call applicant to get information—even to get quotes for placing orders—does not provide a means of ordering the product.”).

⁶⁵ *Id.*

line rules in this context.⁶⁶ However, the CAFC disagreed with Siny's contention that the Board applied improperly rigid requirements. "Rather, the Board carefully considered the Webpage Specimen's contents and determined, on the record before it, that the specimen did not cross the line from mere advertising to an acceptable display associated with the goods."⁶⁷

Unable to find that the Board's decision lacked substantial evidence, the court affirmed the decision.

C. Trademark Trial and Appeal Board

1. Section 2(d) Likelihood of Confusion

a. Likelihood of Confusion Found

In re i.am.symbolic, llc

Observing that the hashtag symbol appended to a term usually has little or no source-identifying significance, the Board affirmed a Section 2(d) refusal to register the mark #WILLPOWER for various items of clothing, in view of the registered word and design mark shown below, for overlapping clothing items [WEAR disclaimed]. The applicant's argument that consumers would recognize that its mark refers to musical performer will.i.am, and that its goods are purchased by his fans, fell on deaf ears.⁶⁸



Because the goods are identical in part, the Board must presume that these goods travel in the same channels of trade to the same classes of consumers.⁶⁹ The applicant pointed out that its "founder is Will Adams, who is known globally under his stage name WILL.I.AM as the front man for the Grammy Award winning and platinum winning musical group The Black Eyed Peas and as a soloist in his own right [and] Mr. Adams' fourth music album is titled '# willpower.'" ⁷⁰ It argued that its goods "are targeted to, and

⁶⁶ *Id.* at *8. See *In re Sones*, 590 F.3d 1282, 93 U.S.P.Q.2d 1118, 1123 (holding that "a picture is not a mandatory requirement for a website-based specimen of use" and disapproving of the "rigid, bright-line rule" the USPTO applied).

⁶⁷ *Id.*

⁶⁸ *In re i.am.symbolic, llc*, 127 U.S.P.Q.2d 1627 (T.T.A.B 2018).

⁶⁹ *Id.* at 1629. See, e.g., *In re Viterra Inc.*, 671 F.3d 1358, 101 U.S.P.Q.2d 1905, 1908 (Fed. Cir. 2012) (even though there was no evidence regarding channels of trade and classes of consumers, the Board was entitled to rely on this legal presumption in determining likelihood of confusion).

⁷⁰ *Id.*

purchased by, wholly different consumers, namely, consumers seeking merchandise in connection with Applicant's album and with Applicant."⁷¹ The Board pointed out, however, that the "respective actual uses and marketing are not reflected in the identification of goods in the application or the cited registration."⁷² "While the applicant may be associated with William Adams, there is nothing in the application that limits the marketing of the goods to methods that would unmistakably associate the goods with him, his persona, or his album."⁷³

Moreover, the Board considered the same applicant's express limitation to goods "associated with William Adams, professionally known as 'will.i.am,'" in a prior decision,⁷⁴ where it ruled that because the cited registrations contained no restriction as to trade channels or consumers, the applicant's "will.i.am restriction does not distinguish the mark sufficiently from the registrants' marks to overcome the evidence of likelihood of confusion."⁷⁵

As to the marks, the Board pointed out once again that when the goods are identical, a lesser degree of similarity between the marks is necessary to establish a likelihood of confusion.⁷⁶ The word WILLPOWER is the dominant portion of the applicant's mark #WILLPOWER. As to the cited mark, the Board, observing that "the verbal portion of a word and design mark [that] likely will be the dominant portion," found that the word "WILLPOWER" is dominant.⁷⁷

The design of stylized mountains in Registrant's mark does not overwhelm, detract from, or change the commercial impression of, the wording WILLPOWER WEAR and HAVE THE WILL, but rather serves as an upper border that attracts the eye to the wording WILLPOWER WEAR. The mountains also resemble stylized W's, focusing attention on the alliterative wording WILLPOWER WEAR, immediately beneath them, as the source identifier.⁷⁸

⁷¹ *Id.*

⁷² *Id.*

⁷³ *Id.*

⁷⁴ *Id.*

⁷⁵ *In re i.am.symbolic, llc*, 866 F.3d 1315, 123 U.S.P.Q.2d 1744 (Fed. Cir. 2017), *aff'd* 116 U.S.P.Q.2d 1406 (T.T.A.B. 2015).

⁷⁶ *I.am.symbolic, llc*, 127 U.S.P.Q.2d at 1630. *See, e.g.*, *Bridgestone Americas Tire Operations, LLC v. Fed. Corp.*, 637 F.3d 1330, 102 U.S.P.Q.2d 1061, 1064 (Fed. Cir. 2012); *Viterra*, 101 U.S.P.Q.2d at 1908.

⁷⁷ *Id.*, quoting *Viterra*, 101 U.S.P.Q.2d at 1911. *See also* *CBS Inc. v. Morrow*, 708 F.2d 1579, 218 U.S.P.Q. 198, 200 (Fed. Cir. 1983) ("[T]he verbal portion of the mark is the one most likely to indicate the origin of the goods to which it is affixed.").

⁷⁸ *Id.* at 1630-31.

Moreover, the slogan “HAVE THE WILL” merely “reinforces” the word “WILLPOWER.”⁷⁹ “WILLPOWER WEAR” “comes across as a single, unified component of the mark” and “HAVE THE WILL” “as a separate part of the mark.”⁸⁰

The applicant argued that the marks are “dramatically and substantially different in appearance,”⁸¹ but the Board did not see it that way: “[T]he focus of Registrant’s mark is on the word WILLPOWER, which would be retained by the consumer more than the other elements.”⁸²

The applicant further contended that #WILLPOWER has a different connotation from the word “WILLPOWER” in the cited registration because in the applicant’s mark the word “WILL” is “meant to play on” the first portion of will.i.am’s stage name.⁸³ The Board pointed out, however, that it must consider the perception of the applicant’s mark by consumers who are not familiar with will.i.am, and who would take the ordinary meaning of the word “willpower” from the mark.⁸⁴

As to the significance of the hashtag, the examining attorney pointed to TMEP § 1202.18, which discusses the impact of the addition of a “#” character to a word. The Board agreed with the Manual that “a hash symbol or the word HASHTAG generally adds little or no source-indicating distinctiveness to a mark.”⁸⁵ “We find, in this case, the hash symbol does not have source-indicating distinctiveness and at most simply appears as the social media tool to create a metadata tag.”⁸⁶

In sum, the Board found the dominant element in the involved marks to be the word “WILLPOWER,” and it concluded that the similarities in the marks outweigh the dissimilarities.

The applicant maintained that the word “willpower” is weak in the field of clothing, pointing to five examples of third-party use of the term “willpower” as part of a mark, but the Board found this evidence insufficient to “show that customers . . . have been educated to distinguish between different . . . marks on the basis of minute distinctions.”⁸⁷

The third-party evidence here is far less in quantity and quality than that in *Juice Generation*, which included at

⁷⁹ *Id.* at 1631.

⁸⁰ *Id.*

⁸¹ *Id.*

⁸² *Id.*

⁸³ *Id.*

⁸⁴ *Id.* at 1632.

⁸⁵ *Id.* at 1633.

⁸⁶ *Id.*

⁸⁷ *Id.* at 1636, quoting *Juice Generation, Inc. v. GS Enters. LLC*, 794 F.3d 1334, 115 U.S.P.Q.2d 1671, 1674 (Fed. Cir. 2015).

least 26 uses or registrations of the same phrase for restaurant services, *Juice Generation*, 115 U.S.P.Q.2d at 1673 n.1, or in *Jack Wolfskin* where there were at least fourteen, [797 F.3d 1363, 116 U.S.P.Q.2d 1129, 1136 n.2].⁸⁸

b. Likelihood of Confusion Not Found

In re FabFitFun, Inc.

Agreeing with Applicant FabFitFun that the term “SMOKIN’ HOT” is a weak formative in the field of cosmetics, the Board reversed a Section 2(d) refusal of I’M SMOKING HOT for cosmetics, makeup, and other personal care products, finding the mark not likely to cause confusion with the registered mark SMOKIN’ HOT SHOW TIME for cosmetics.⁸⁹

Because the involved goods overlap, the Board must presume that those overlapping goods travel in the same trade channels to the same classes of consumers.⁹⁰ Moreover, the goods as identified include lower cost makeup items that may be purchased without a high degree of care.⁹¹ These *du Pont* factors favored a finding of likely confusion.

As to the strength of the cited mark, the Board first considered the conceptual strength of the term “smokin(g) hot.” A dictionary definition (“attractive, sexy looking, very hot”) led the Board to conclude that “the purpose or intended result of the cosmetics offered under the marks at issue is to render the user’s appearance ‘smoking hot.’”⁹² Thus, the term has some conceptual weakness and is at best highly suggestive for cosmetics.⁹³

As to marketplace strength, Applicant FabFitFun submitted screenshots showing ten third-party uses of SMOKIN’ HOT formatives as marks for cosmetics, and particularly for eye makeup. The CAFC held in *Jack Wolfskin* that “*extensive* evidence of third-party use and registrations is ‘powerful on its face,’ even where the

⁸⁸ *Id.*

⁸⁹ *In re FabFitFun, Inc.*, 127 U.S.P.Q.2d 1670 (T.T.A.B. 2018).

⁹⁰ *Id.* at 1672-73, citing *Viterra*, 101 U.S.P.Q.2d at 1908; *In re Smith & Mehaffey*, 31 U.S.P.Q.2d 1531, 1532 (T.T.A.B. 1994) (“Because the goods are legally identical, they must be presumed to travel in the same channels of trade, and be sold to the same class of purchasers[.]”).

⁹¹ *Id.* at 1673. See *Recot Inc. v. M.C. Becton*, 214 F.3d 1322, 54 U.S.P.Q.2d 1894, 1899 (Fed. Cir. 2000) (“When products are relatively low-priced and subject to impulse buying, the risk of likelihood of confusion is increased because purchasers of such products are held to a lesser standard of purchasing care.”).

⁹² *Id.*

⁹³ *Id.*

specific extent and impact of the usage has not been established.”⁹⁴ However, FabFitFun’s evidence was “more modest” than the amount of evidence in *Jack Wolfskin* and *Juice Generation*.⁹⁵

Nonetheless, the Board found the shared term SMOKIN’ [SMOKING] HOT to be “somewhat weak in that it at best suggests a desired result of using the identified cosmetics, while the third-party uses . . . tend to show consumer exposure to thirdparty [sic] use of the term on similar goods.”⁹⁶

In sum, the Board found the shared term “SMOKIN’ HOT” to be “somewhat weak.”⁹⁷ The entire mark SMOKIN’ HOT SHOW TIME, however, was not shown to be either particularly strong or particularly weak.⁹⁸

On balance, we do not believe that, on this record, the relative strength of the cited mark in its entirety weighs significantly one way or the other. Rather, the relative weakness of the component term SMOKIN’ HOT common to both marks weighs somewhat in favor of a finding of no likelihood of confusion.⁹⁹

The Board perceptively observed that the only common element is the term “SMOKIN’ HOT”/ “SMOKING HOT,” a term that is a weak source identifier in the field of cosmetics.¹⁰⁰ The differences in structure between the two marks renders them “only somewhat similar in sound and appearance.”¹⁰¹ The connotations and overall commercial impressions of the two marks “are more different than they are similar.”¹⁰² “While both generally connote attractiveness or sexiness due to the shared component SMOKIN’ HOT/SMOKING HOT, Applicant’s mark in its entirety conveys the impression of a statement regarding one’s personal appearance and the registered mark conveys sexy entertainment.”¹⁰³

Considering the marks in their entireties, the Board found them to be more dissimilar than similar, and it concluded that confusion is not likely.

⁹⁴ *Id.* at 1674, quoting *Jack Wolfskin Ausrüstung Fur Draussen GmbH & Co. KGAA v. New Millennium Sports, S.L.U.*, 797 F.3d 1363, 116 U.S.P.Q.2d 1129, 1136 (Fed. Cir. 2015) (emphasis added) (citing *Juice Generation*, 115 U.S.P.Q.2d at 1674).

⁹⁵ *Id.* at 1674-75.

⁹⁶ *Id.* at 1675.

⁹⁷ *Id.*

⁹⁸ *Id.*

⁹⁹ *Id.*

¹⁰⁰ *Id.* at 1676.

¹⁰¹ *Id.*

¹⁰² *Id.* at 1677.

¹⁰³ *Id.*

In re American Cruise Lines, Inc.

The Board gave “great weight” to two consent agreements, in reversing a Section 2(d) refusal to register the mark AMERICAN CONSTELLATION, finding it not likely to cause confusion with the registered mark CONSTELLATION, both for cruise ship services. The examining attorney maintained that these were “naked” consents because they did not set forth the steps the parties would take to avoid confusion, but the Board pointed out that such terms are not mandatory or essential for a consent to have probative value.¹⁰⁴

Because the services involved are identical, the Board must presume that the channels of trade and the classes of consumers for the applicant’s mark and the cited mark are the same.¹⁰⁵ The applicant asserted that selecting a cruise is not an impulse purchase, but is “based on careful research and investigation in light of the purchaser’s travel goals and travel budget.”¹⁰⁶ The applicant supported this assertion with the testimony of one its officers, and with a statement by the registrant’s CEO from one of the consent agreements. The examining attorney contended these two (self-serving) statements must be corroborated by additional evidence, but the Board disagreed: the examining attorney “disregards that the statements were made by two people who work in the cruise ship service industry” and even if the statement of the applicant’s officer were deemed less persuasive, “the statement of Registrant’s officer certainly must be considered probative evidence on this point.”¹⁰⁷ The Board found that customers for the involved services exercise a heightened degree of care when selecting cruise ship services.

The Board next found that the marks have a similar meaning and convey a similar commercial impression “because the name AMERICAN CONSTELLATION means and engenders the commercial impression of an American star or group.”¹⁰⁸ The fact that the cited mark is contained in the applicant’s mark increases the similarity between the two.

The examining attorney maintained that the consent agreements were not probative because they were “naked”: i.e., they did not describe the arrangements to avoid confusion and did not contain any agreement regarding efforts to avoid confusion. The Board, however, found that the second of the two consent agreements was “clothed” because it stated why the applicant and registrant believed confusion was not likely: the parties provide

¹⁰⁴ *In re Am. Cruise Lines, Inc.*, 128 U.S.P.Q.2d 1157 (T.T.A.B. 2018).

¹⁰⁵ *Id.* at 1158. *See Viterra*, 101 U.S.P.Q.2d at 1908 (legally identical goods are presumed to travel in same channels of trade to same class of purchasers).

¹⁰⁶ *Id.* at 1159.

¹⁰⁷ *Id.* at 1159-60.

¹⁰⁸ *Id.* at 1160-61.

services in different areas of the world; the applicant always refers to its ship as AMERICAN CONSTELLATION and agreed not to refer to it as CONSTELLATION; cruise ship customers exercise a heightened degree of care in selecting a cruise; customers know that the applicant uses “American” as a house mark; both parties have coexisted for more than ten years without any reported incidents of confusion; and other cruise lines operate under names that share common terms (e.g., LEGEND and LEGEND OF THE SEAS).¹⁰⁹ Moreover, the Board rejected the examining attorney’s position that a consent agreement must contain a provision regarding avoidance of confusion.

A provision in the consent agreement that the parties agree to make efforts to prevent confusion or to cooperate and take steps to avoid any confusion that may arise in the future may render the agreement *more* probative, but it is not an essential provision for the agreement to have probative value [N]o authority requires that parties explicitly agree to make efforts to prevent confusion or to cooperate and take steps to avoid any confusion that may arise in the future as a prerequisite to giving some weight to a consent agreement.¹¹⁰

In sum, “[w]hile the inclusion of provisions to avoid any potential confusion are preferred and probative in consent agreements, they are not mandatory.”¹¹¹

The Board pointed out that the statement in the second agreement that the applicant and the registrant operate in different areas of the world is not probative, since that restriction is not reflected in the application or cited registration. However, the remaining four provisions “are probative that the consent agreement reflects the reality of no likelihood of confusion in the marketplace.”¹¹² Therefore, the subject consent to use and register “weighs heavily” against a likelihood of confusion.¹¹³

“[C]lothed” consent agreements where “competitors have clearly thought out their commercial interests” should be given great weight, and the USPTO should not substitute its judgment concerning likelihood of confusion for the judgment of the real parties in interest without good reason,

¹⁰⁹ *Id.* at 1161-62.

¹¹⁰ *Id.* at 1162.

¹¹¹ *Id.*

¹¹² *Id.* at 1162-63.

¹¹³ *Id.* at 1163.

that is, unless the other relevant factors clearly dictate a finding of likelihood of confusion.¹¹⁴

2. Section 2(e)(1) Mere Descriptiveness

In re S. Malhotra & Co. AG

Applying the doctrine of foreign equivalents, the Board affirmed Section 2(e)(1) refusals of the marks GÁMOS in standard character form, and the stylized word mark shown below, finding the marks to be merely descriptive of “precious metals and their alloys and goods made of these materials or coated therewith included in this class, namely, jewelry and watches.”¹¹⁵ The Board concluded that consumers familiar with the Greek language would immediately understand that the marks “convey information about a feature of those goods, namely, that they may be used in association with weddings.”¹¹⁶



The application for the standard character mark stated that the English translation of “GÁMOS” is “wedding, matrimony or marriage.” The stylized mark application stated that the non-Latin characters in the mark transliterate to “GÁMOS.”

Under the doctrine of foreign equivalents, foreign words from common languages are translated into English to determine, inter alia, descriptiveness.¹¹⁷ The doctrine applies only when the ordinary American purchaser would likely “stop and translate [the word] into its English equivalent.”¹¹⁸ The “ordinary American purchaser” includes those proficient in a non-English language who would be expected to translate words into English.¹¹⁹

The Board took judicial notice of U.S. Census data indicating that more than 300,000 individuals over five years old speak Greek at home, leading it to find that Greek is a common, modern language and is not dead or obscure.

¹¹⁴ *Id.* See *In re Four Seasons Hotels Ltd.*, 987 F.2d 1565, 26 U.S.P.Q.2d, 1071, 1073 (quoting *In re N.A.D. Inc.*, 74 F.2d 996, 224 U.S.P.Q. 969 (Fed. Cir. 1985)); see also *du Pont*, 177 U.S.P.Q. at 568 (“A mere assumption that confusion is likely will rarely prevail against uncontroverted evidence from those on the firing line that it is not.”).

¹¹⁵ *In re S. Malhotra & Co. AG*, 128 U.S.P.Q.2d 1100 (T.T.A.B. 2018).

¹¹⁶ *Id.* at 1105.

¹¹⁷ *Id.* at 1102. See *Palm Bay Imps., Inc. v. Veuve Clicquot Ponsardin Maison Fondée En 1772*, 396 F.3d 1369, 73 U.S.P.Q.2d 1689, 1696 (Fed. Cir. 2005).

¹¹⁸ *Palm Bay*, 73 U.S.P.Q.2d at 1696.

¹¹⁹ *In re Highlights for Children, Inc.*, 118 U.S.P.Q.2d 1268, 1271 (T.T.A.B. 2016) (quoting *In re Spirits Int'l N.V.*, 563 F.3d 1347, 90 U.S.P.Q.2d 1489, 1492 (Fed. Cir. 2009)).

Applicant Malhotra argued that the doctrine is inapplicable because its claimed marks do not have literal and direct translations, but instead have “well-established alternative meanings,” including “union,” “small deer,” “buck” and “a sexual ritual that plays out a marriage between a god and a goddess.”¹²⁰ The Board, however, agreed with the examining attorney that the “small deer” and “buck” translations relate to the unaccented Spanish words “gamos” and “gamo,” that “union” is not listed as a translation of either of the marks but merely as one of several “similar phrases,” and that the referenced sexual ritual is actually called “hieros gamos.”¹²¹

Dictionary definitions of “marriage,” “matrimony,” and “wedding” demonstrated that these words are highly related. The Board found that the proposed marks have definite English translations and that ordinary Americans would stop and translate the marks.

As to mere descriptiveness, the examining attorney introduced extensive evidence of use of the word “wedding” to describe jewelry specifically intended for weddings. Malhotra, as mentioned, asserted that the word “GÁMOS” has no single meaning in connection with its goods and therefore cannot be merely descriptive of them. The Board disagreed:

We have found that “marriage,” “matrimony,” and “wedding” have highly related meanings, and the evidence shows that “wedding” has descriptive significance in association with jewelry. Specifically, “wedding” is merely descriptive of a type of jewelry worn for weddings, a feature or characteristic of the goods. Moreover, “[i]t is well settled that so long as any one of the meanings of a term is descriptive, the term may be considered to be merely descriptive.”¹²²

Finally, Malhotra feebly argued that its claimed marks are double entendres, since they may suggest “that Applicant’s jewelry and watches have a combination of multiple parts or [involve a] ‘marriage of metals’ technique.”¹²³ The Board said no-no. For a term to avoid a Section 2(e)(1) refusal as a double entendre, the second, non-descriptive meaning of the term must be apparent from the mark itself.¹²⁴ There was no evidence that consumers would

¹²⁰ *S. Malhotra & Co.*, 128 U.S.P.Q.2d at 1103.

¹²¹ *Id.*

¹²² *Id.* at 1105, quoting *In re Chopper Indus.*, 222 U.S.P.Q. 258, 259 (T.T.A.B. 1984); see also *In re IP Carrier Consulting Group*, 84 U.S.P.Q.2d 1028, 1034 (T.T.A.B. 2007); *In re Bright-Crest, Ltd.*, 204 U.S.P.Q. 591, 593 (T.T.A.B. 1979).

¹²³ *Id.*

¹²⁴ *Id.*, citing *In re Colonial Stores Inc.*, 394 F.2d 549, 157 U.S.P.Q. 382, 385 (C.C.P.A. 1968) (holding SUGAR & SPICE not merely descriptive for bakery products because it readily conjures a familiar phrase in a well-known nursery rhyme).

understand the two marks to have the meanings that Malhotra proposed, nor are those meanings evident from the marks themselves when considered in the context of the goods.

The Board concluded that consumers familiar with Greek will immediately understand the marks to convey information about a feature of the applicant's goods, namely, that they may be used in association with weddings.

3. Section 2(e)(2) Primarily Geographically Descriptive

In re Broken Arrow Beef and Provision, LLC

The Board reversed a Section 2(e)(2) refusal to register the mark BA BEEF for “beef; flavored nuts; frozen fish; pork; poultry; preserved fish; processed pecans; seasoned nuts; chicken” [BEEF disclaimed], finding that the USPTO had failed to prove that the mark is primarily geographically descriptive of the goods. The examining attorney contended that “BA” is an abbreviation for Broken Arrow, Oklahoma, where the applicant is located, but the record evidence was insufficient to show that “BA” would be recognized as identifying “a place known generally to the beef-purchasing public in the United States.”¹²⁵

Section 2(e)(2) of the Lanham Act bars registration on the Principal Register of a mark which “when used on or in connection with the goods of the applicant is primarily geographically descriptive of them.”¹²⁶ To establish that a mark is primarily geographically descriptive, the USPTO must prove three elements:

- (1) the mark sought to be registered is the name of a place known generally to the public, (2) the public would make a goods/place association, i.e., believe that the goods for which the mark is sought to be registered originate in that place, [and] (3) the source of the goods is the geographic region named in the mark.¹²⁷

The Board deemed it necessary to consider only the first element of the Section 2(e)(2) test. The examining attorney relied on websites, search results, social media pages, and various printed materials as proof that the acronym “BA” is an abbreviation for “Broken Arrow” and that the primary significance of “BA” is a generally known geographic location.

The applicant argued that “the average American beef consumer would not likely associate the initials BA with any geographic location.”¹²⁸ It asserted that, although local residents sometimes

¹²⁵ *In re Broken Arrow Beef and Provision, LLC*, 129 U.S.P.Q.2d 1431 (T.T.A.B. 2019).

¹²⁶ 15 U.S.C. § 1052(e)(2) (2012).

¹²⁷ *In re Newbridge Cutlery Co.*, 776 F.3d 854, 113 U.S.P.Q.2d 1445, 1448-49 (Fed. Cir. 2015) (internal quotations and citations omitted).

¹²⁸ *Broken Arrow Beef*, 129 U.S.P.Q.2d at 1433.

refer to Broken Arrow as “BA,” a beef consumer elsewhere in the country would not know what “BA” meant: “[I]t might be Buenos Aries beef, Big Al’s beef, Best Anywhere beer, British Airways beef, Bay Area beef, or simply BA (pronounced ‘bah’ or ‘bay’) beef.”¹²⁹

The Board found instructive its decision in *In re Trans Continental Records, Inc.*,¹³⁰ reversing a requirement for disclaimer of the word “O-TOWN,” a nickname for Orlando, Florida. There, despite evidence of use of the nickname in national media, the Board ruled that, “[a]lthough people in Orlando and parts of Florida may be aware of the nickname,” it could not find that “consumers elsewhere in the country are aware that O-TOWN is another name for the city of Orlando.”¹³¹ The Board concluded that “the limited number of articles reflecting that O-TOWN is a nickname for Orlando is not sufficient for us to conclude that O-TOWN is anything but an obscure geographic term.”¹³²

Here, the evidence regarding the meaning of “BA” was “quantitatively more extensive” than that for “O-TOWN,” but was “no better qualitatively.”¹³³ Website searches showed that “BA” has “a handful of geographic-related meanings, but most are obscure, and none pertain to Broken Arrow, Oklahoma.”¹³⁴ Unlike “O-TOWN,” which refers on its face to a geographic place, “the letters ‘BA’ . . . have no obvious, generally known geographic significance, much less as a known abbreviation for Broken Arrow, Oklahoma.”¹³⁵

The examining attorney relied on evidence of use of the letters “BA” as an abbreviation for Broken Arrow in online references to a wide variety of businesses, schools, churches, and media, all located in and around Broken Arrow. This evidence included in newspaper articles in *The Daily Oklahoman*, *Tulsa World*, *Broken Arrow World*, *The Christian Science Monitor*, and the *Dallas Morning News*; “BA” was also referred to on the city’s governmental website.

The Board found it “hardly surprising” that “most locals” refer to Broken Arrow as “BA.”¹³⁶ The Board has previously found that it is common for cities to be referred to by nicknames or abbreviations: e.g., “the ATL,”¹³⁷ and “CUBA L.A.”¹³⁸ The relevant issue, however, was not whether “locals” recognize “BA” as an abbreviation for

¹²⁹ *Id.*

¹³⁰ 62 U.S.P.Q.2d 1541 (T.T.A.B. 2002).

¹³¹ *Id.* at 1543.

¹³² *Id.*

¹³³ *Broken Arrow Beef*, 129 U.S.P.Q.2d at 1434.

¹³⁴ *Id.* at 1435.

¹³⁵ *Id.*

¹³⁶ *Id.* at 1443.

¹³⁷ *In re Cox Enters. Inc.*, 82 U.S.P.Q.2d 1040 (T.T.A.B. 2007).

¹³⁸ *In re Narada Prods. Inc.*, 57 U.S.P.Q.2d 1801 (T.T.A.B. 2001).

“Broken Arrow,” but “whether beef consumers throughout the entire United States would understand that ‘BA’ in the mark relates to a geographic place.”¹³⁹

Here, Applicant’s goods are directed to the general public, not just to consumers in Broken Arrow, Oklahoma. Even assuming that “BA’ is likely a well-known geographic term to the more than 1 million people in the Tulsa metropolitan area,” as the Examining Attorney claims, . . . and that the articles in the non-Oklahoma publications have exposed the abbreviation BA to some beef consumers outside Oklahoma, we cannot find, based on the entire record, that the letters BA in the applied-for mark BA BEEF identify “a place known generally to the relevant American public.”¹⁴⁰

The Board agreed with the applicant that “BA” “is no NYC, LA, or even ATL,” particularly in view of the multiple non-geographic meanings of “BA.”¹⁴¹ In sum, based on the record evidence, “BA” is “a relatively obscure term which would not be perceived as a geographic reference to’ Broken Arrow, Oklahoma by beef consumers outside Broken Arrow.”¹⁴² And so, because the USPTO did not establish the “threshold element” of geographic descriptiveness, the Board did not, and was not required to, consider the other elements of the Section 2(e)(2) test.¹⁴³

4. Section 2(f) Acquired Distinctiveness

In re SnowWizard, Inc.

Because Applicant SnowWizard, Inc. failed to prove acquired distinctiveness under Section 2(f), the Board affirmed a refusal to register the product configuration mark shown below, for “[c]oncession trailer for snowball vendors to operate a viable snowball business” [the word SNOBALLS disclaimed].¹⁴⁴ After rejecting SnowWizard’s claim that the mark at issue constitutes

¹³⁹ *Broken Arrow Beef*, 129 U.S.P.Q.2d at 1443.

¹⁴⁰ *Id.* at 1443-44, quoting *Newbridge Cutlery*, 113 U.S.P.Q.2d at 1450.

¹⁴¹ *Id.* at 1444.

¹⁴² *Id.*, quoting *Trans Cont’l Records*, 62 U.S.P.Q.2d 1544.

¹⁴³ *Id.*, citing *Newbridge Cutlery*, 113 U.S.P.Q.2d at 1451; *Trans Cont’l Records*, 62 U.S.P.Q.2d at 1544.

¹⁴⁴ Section 2(f) of the Lanham Act, 15 U.S.C. § 1052(f) (2012), provides in pertinent part:

Except as expressly excluded in subsections (a), (b), (c), (d), (e)(3), and (e)(5) of this section, nothing herein shall prevent the registration of a mark used by the applicant which has become distinctive of the applicant’s goods in commerce. The Director may accept as prima facie evidence that the mark has become distinctive, as used on or in connection with the applicant’s goods in commerce, proof of substantially exclusive and continuous use thereof as a mark by the applicant in commerce for the five years before the date on which the claim of distinctiveness is made.

packaging trade dress (which can be inherently distinctive) rather than product design (which cannot), the Board applied the CAFC's recently minted *Converse*¹⁴⁵ factors to the Section 2(f) issue.¹⁴⁶

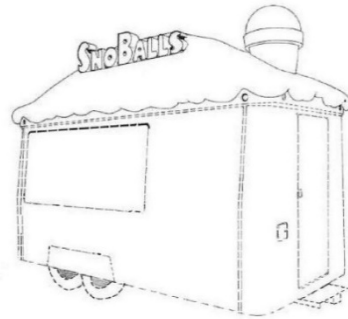

Product Packaging or Product Design?: In the subject application, the proposed mark is described as “a three-dimensional configuration of a snowcapped roof with the word ‘SNOBALLS,’ a snowball and associated beverage container positioned on top of a concession trailer for snowball vendors.”¹⁴⁷ SnoWizard sought registration under Section 2(f) of the Lanham Act, thereby, according to the Board, “effectively” conceding that its mark is not inherently distinctive.¹⁴⁸ Nonetheless, SnoWizard had preserved its argument that the mark constitutes inherently distinctive product packaging, not product design.

Although a product design mark can never be inherently distinctive, product packaging marks can be.¹⁴⁹ In *Wal-Mart*, the Supreme Court stated that, in close cases, “courts should err on the side of caution and classify ambiguous trade dress as product design, thereby requiring secondary meaning,”¹⁵⁰ but the Board pointed out that “this is not a close case.”¹⁵¹

Clearly, the product at issue in this case is the concession trailer; that is the product offered for sale, purchased by, and used by snowball vendors. It is not a container for flavored shaved ice or snowballs sold to consumers, as suggested by Applicant. Accordingly, Applicant’s applied-for mark is properly characterized as a product design.¹⁵²

¹⁴⁵ *Converse Inc. v. ITC*, 909 F.3d 1110, 128 U.S.P.Q.2d 1538 (Fed. Cir. 2018).

¹⁴⁶ *In re SnoWizard, Inc.*, 129 U.S.P.Q.2d 1001 (T.T.A.B. 2018).

¹⁴⁷ *Id.* at 1001-02.

¹⁴⁸ *Id.* at 1002. *See In re MGA Entm’t, Inc.*, 84 U.S.P.Q.2d 1743, 1747 (T.T.A.B. 2007).

¹⁴⁹ *Id.* *See Wal-Mart Stores Inc. v. Samara Bros Inc.*, 529 U.S. 205, 54 U.S.P.Q.2d 1065, 1069 (2000) (citing *Two Pesos, Inc. v. Taco Cabana, Inc.*, 505 U.S. 763, 23 U.S.P.Q.2d 1081 (1992)).

¹⁵⁰ *Wal-Mart*, 54 U.S.P.Q.2d at 1070.

¹⁵¹ *SnoWizard*, 129 U.S.P.Q.2d at 1003.

¹⁵² *Id.*

And so SnoWizard was required to prove its claim of acquired distinctiveness under Section 2(f).

Acquired Distinctiveness: The Board applied the “secondary meaning” factors set out by the CAFC in *Converse*:

[T]he considerations to be assessed in determining whether a mark has acquired secondary meaning can be described by the following six factors: (1) association of the trade dress with a particular source by actual purchasers (typically measured by customer surveys); (2) length, degree, and exclusivity of use; (3) amount and manner of advertising; (4) amount of sales and number of customers; (5) intentional copying; and (6) unsolicited media coverage of the product embodying the mark.¹⁵³

SnoWizard’s annual sales of the “claimed trade dress concession trailer”¹⁵⁴ averaged approximately \$35,000 per year over the past nine years. The Board found this figure to be meaningless, since there was no information as to the cost of each concession trailer, how many consumers have purchased the trailers, or how many trailers SnoWizard sold per year. “Indeed, one could reasonably assume that the sales average is modest for large items such as concession trailers.”¹⁵⁵ In any case, even assuming that the sales were more than modest, “mere figures demonstrating successful product sales are not probative of purchaser recognition of a configuration as an indication of source.”¹⁵⁶

The Board noted that “look for” advertising may be “particularly probative on the issue of whether a product design functions as a source identifier,”¹⁵⁷ but the record was devoid of any such advertising. Moreover, SnoWizard did not provide:

any of the other kinds of evidence that may show that the mark has acquired distinctiveness, namely: (1) advertising figures for its goods, (2) the number of customers for its goods, (3) evidence regarding its exclusivity of use, (4) the unit amount of concession trailers it has sold, (5) evidence demonstrating an association of Applicant’s applied-for product design or trade dress with Applicant by actual purchasers, (6) evidence showing that others have intentionally copied Applicant’s product design, or

¹⁵³ 128 U.S.P.Q.2d at 1546.

¹⁵⁴ *SnoWizard*, 129 U.S.P.Q.2d at 1005.

¹⁵⁵ *Id.* at 1006.

¹⁵⁶ *Id.*, citing *Stuart Spector Designs, Ltd. v. Fender Musical Instruments Corp.*, 94 U.S.P.Q.2d 1549, 1572 (T.T.A.B. 2009).

¹⁵⁷ *Id.*

(7) unsolicited media coverage of its concession trailer product design.¹⁵⁸

The examining attorney submitted evidence that concession trailers with decorative roofs having representations of ice, snow cones, and similar food items are “not uncommon.”¹⁵⁹ There was no indication that any of the third-party configurations were “perceived by consumers as indicators of source for any goods or services, let alone for the trailers themselves.”¹⁶⁰

Moreover, while these third-party uses of concession trailer designs may not be substantially similar to Applicant’s applied-for mark, this evidence nonetheless shows that consumers are accustomed to seeing decorative roofs with snow cones, ice cream and similar food item designs on concession trailers and the like, presented in a non-source-indicating manner. Under such circumstances, consumers for concession trailers would look to differently designed concession trailer roofs as being aesthetic features, or generally advertising food items sold within, rather than acting as an indicator of source.¹⁶¹

Weighing the *Converse* factors, the Board found that SnoWizard failed to prove acquired distinctiveness in its product configuration, and so the Board affirmed the refusal to register under Sections 1, 2, and 45 of the Lanham Act.

5. Failure to Function

In re Peace Love World Live, LLC

In one of a growing stream of failure-to-function cases, the Board showed no ♥ for this applicant, affirming a refusal to register the mark I LOVE YOU for bracelets because it found that the phrase is merely ornamental and, therefore, fails to function as a trademark. To add insult to injury, the Board also affirmed a Section 2(d) refusal on the ground of likelihood of confusion with the registered mark I LUV U for “jewelry, namely, necklaces, bracelets, rings and charms; pendants; earrings.”¹⁶²

¹⁵⁸ *Id.* at 1007. *See, e.g., Converse*, 128 U.S.P.Q.2d at 1546; *Coach Servs., Inc. v. Triumph Learning LLC*, 668 F.3d 1356, 101 U.S.P.Q.2d 1713, 1729 (Fed. Cir. 2012); *Steelbuilding.com*, 75 U.S.P.Q.2d at 1424.

¹⁵⁹ *Id.*

¹⁶⁰ *Id.* at 1008.

¹⁶¹ *Id.*

¹⁶² *In re Peace Love World Live, LLC*, 127 U.S.P.Q.2d 1400 (T.T.A.B. 2018). The Board refused to consider the argument, raised for the first time in the examining attorney’s brief, that the proposed mark is a widely used informational message that is incapable of functioning as a mark.

In assessing a failure-to-function refusal, particularly whether the mark is merely ornamental, the Board may consider whether the mark at issue is a common expression.¹⁶³ The examining attorney, however, did not request remand to the USPTO in order to make an alternative refusal that the mark fails to function because it is a common expression incapable of indicating source. And so, the failure-to-function refusal was grounded on ornamentality.

Failure to Function: The examining attorney contended that the proposed mark “conveys the common expression of endearment,” supporting this assertion with numerous examples of “I LOVE YOU” and variations thereof used on bracelets and other jewelry.¹⁶⁴ The crucial question, of course, was whether the purported mark would be perceived as a source indicator.¹⁶⁵

The size, location, dominance, and significance of the mark are relevant to the determination.¹⁶⁶ Here, the phrase I LOVE YOU is “essentially the bracelet itself.”¹⁶⁷



The Board found that the phrase “conveys a term of endearment comprising the bracelet and, thus, it is ornamental. It does not identify and distinguish the source of the bracelet, especially where there is so much jewelry decorated with the words “I LOVE YOU” in the marketplace.” The ornamental nature of the phrase was corroborated by third-party use on bracelets and other jewelry, such

¹⁶³ See TMEP § 1202.03(a) (2017). “Common expressions and symbols (e.g., the peace symbol, ‘smiley face,’ or the phrase ‘Have a Nice Day’) are normally not perceived as marks.”

¹⁶⁴ *Peace Love World Live*, 127 U.S.P.Q.2d at 1402. See *D.C. One Wholesaler, Inc. v. Chien*, 120 U.S.P.Q.2d 1710, 1716 (T.T.A.B. 2016) (widespread ornamental use of I ♥ DC may influence how the mark is perceived).

¹⁶⁵ *Id.* at 1403. See *In re Keep a Breast Found.*, 123 U.S.P.Q.2d 1869, 1879 (T.T.A.B. 2017); *In re Hulting*, 107 U.S.P.Q.2d 1175, 1177-79 (T.T.A.B. 2013); *In re Lululemon Athletica Can. Inc.*, 105 U.S.P.Q.2d 1684, 1686 (T.T.A.B. 2013).

¹⁶⁶ *Id.* See *In re Hulting*, 107 U.S.P.Q.2d at 1178 (NO MORE RINOS fails to function as a trademark for bumper stickers, clothing, and campaign buttons).

¹⁶⁷ *Id.*

that consumers are accustomed to seeing the phrase on items from other sources.¹⁶⁸

Applicant Peace maintained that “I LOVE YOU” is the “theme of the product,” but that contention merely supported the Board’s finding that the words are an aesthetic feature of the goods and that consumers will perceive the phrase as an important component of the product, rather than as a trademark.¹⁶⁹

Peace also maintained that customers recognized the “common distinctive thread” of its products—“love and peace oriented themes having playful and chunky design elements.”¹⁷⁰ The Board pointed out, however, that Peace was seeking to register a word mark in standard characters. In any case, the “look of the letters as they appear on the goods in the specimen is a reason I LOVE YOU would be perceived as mere ornamentation”¹⁷¹ Moreover, Peace did not seek to register the proposed mark under Section 2(f), and so the Board could not consider Peace’s argument regarding the renown of its business or customer recognition of the common style of its products.

In any case, the Board noted, the evidence appeared to preclude any claim of acquired distinctiveness under Section 2(f) because Peace’s use had not been substantially exclusive.

Likelihood of Confusion: Both the subject application and the cited registration included “bracelets,” so the Board must assume that these items travel in the same trade channels and to the same classes of customers, namely, ordinary consumers.¹⁷² Moreover, when the involved goods are identical, a lesser degree of similarity between the marks is necessary to support a finding of likely confusion.¹⁷³

Arguing that the cited mark is entitled to only a narrow scope of protection, Applicant Peace submitted seven third-party registrations for variations of I LOVE YOU for jewelry: I WILL LOVE YOU FOREVER, I LOVE YOU ALWAYS & Design, P.S. I LOVE YOU, THE NEW WAY TO SAY I LOVE YOU, I LOVE YOU EACH DAY OF THE WEEK, MORE THAN 100 WAYS OF SAYING LOVE, AND LUV HER.¹⁷⁴ The Board, however, pointed out again that I LOVE YOU is a commonly used term of endearment displayed on jewelry. Consequently, “consumers are conditioned to look for

¹⁶⁸ *Id.*

¹⁶⁹ *Id.* at 1404. *See D.C. One Wholesaler*, 120 U.S.P.Q.2d at 1716 (“the display [of the mark] itself is an important component of the product and customers purchase the product precisely because it is ornamented with a display of the term”).

¹⁷⁰ *Id.*

¹⁷¹ *Id.*

¹⁷² *Id.* *See In re Viterra Inc.*, 101 U.S.P.Q.2d at 1908.

¹⁷³ *Id.* at 1407. *See, e.g., Coach Servs.*, 101 U.S.P.Q.2d at 1721.

¹⁷⁴ *Id.* at 1406.

differences among trademarks consisting of or including I LOVE YOU for jewelry.”¹⁷⁵

Peace contended that I LOVE YOU has a traditional feel, whereas I LUV YOU “is used as an abbreviation in telecommunications” such as texting and social media entries.¹⁷⁶ The Board was unmoved: “Even assuming that I LOVE YOU has a traditional feel . . . the marks still look alike, sound alike, mean the same thing and engender the same commercial impression (*i.e.*, a term of endearment).”¹⁷⁷ The slight differences in spelling do not distinguish the marks.¹⁷⁸

The Board concluded that the “strong similarity” between the marks weighs in favor of a likelihood of confusion.¹⁷⁹ Balancing the relevant *du Pont* factors, the Board found confusion likely, and it affirmed the Section 2(d) refusal.

In re Wal-Mart Stores, Inc.

Finding that the purported mark INVESTING IN AMERICAN JOBS fails to function as a service mark for “promoting public awareness for goods made or assembled by American workers” and for various retail and online store services, the Board affirmed this refusal to register. It concluded that INVESTING IN AMERICAN JOBS, as used by Wal-Mart, “would be perceived by customers as a merely informational phrase” and not as an indicator of source.¹⁸⁰

The Board observed that the CAFC and its predecessor, the CCPA, as well as other federal courts, “draw a distinction between words used to ‘identify and distinguish’ source, and words used in their ordinarily-understood meaning to convey information other than source-identification.”¹⁸¹ For example, the phrases “Drive Safely,” “Think Green,” and “You Have Mail” have been deemed unregistrable as trademarks.¹⁸²

A critical question is “whether the phrase sought to be registered would be perceived as a mark identifying the source of the services,

¹⁷⁵ *Id.*

¹⁷⁶ *Id.* at 1407.

¹⁷⁷ *Id.*

¹⁷⁸ *Id.* See, e.g., *In re Great Lakes Canning, Inc.*, 227 U.S.P.Q. 483, 485 (T.T.A.B. 1985) (CAYNA is similar to CANA); *In re Energy Telecomms. & Elec. Ass’n*, 222 U.S.P.Q. 350, 351 (T.T.A.B. 1983) (ENTELEC is similar to INTELECT).

¹⁷⁹ *Id.*

¹⁸⁰ *In re Wal-Mart Stores, Inc.*, 129 U.S.P.Q.2d 1148, 1160 (T.T.A.B. 2019).

¹⁸¹ *Id.* at 1149-50.

¹⁸² *In re Volvo Cars of N. Am.*, 46 U.S.P.Q.2d 1455 (T.T.A.B. 1998) (DRIVE SAFELY for automobiles and parts); *In re Manco Inc.*, 24 U.S.P.Q.2d 1062 (T.T.A.B. 1992) (THINK GREEN for mailing and shipping boxes, and for weatherstripping); *Am. Online, Inc. v. AT&T Corp.*, 243 F.3d 812, 57 U.S.P.Q.2d 1902 (4th Cir. 2001) (YOU HAVE MAIL for Internet services).

or as something else.”¹⁸³ In making this determination, the Board reviews the specimens and other evidence that show how the purported mark is used in the marketplace.

Looking first to Wal-Mart’s own use of the phrase, its specimen of use was a shelf-talker located in close proximity to products that are made by American workers. The phrase also appears as the title on a web page on which Wal-Mart states: “We believe we can create more American jobs by supporting more American manufacturing.”¹⁸⁴

The slogan INVESTING IN AMERICAN JOBS is like other statements that would ordinarily be used in business or industry, or by certain segments of the public generally, to convey support for American-made goods, and thus would not be recognized as indicating source and are not registrable. *See, e.g., In re Remington Prods.*, 3 U.S.P.Q.2d 1714, 1715 (T.T.A.B. 1987) (PROUDLY MADE IN USA for electric shavers and parts thereof would not be recognized as source indicator); *see also In re Eagle Crest*, 96 U.S.P.Q.2d 1227, 1232 (T.T.A.B. 2010) (ONCE A MARINE, ALWAYS A MARINE for clothing)¹⁸⁵

The Board, therefore, found that the proposed mark would be perceived by consumers as merely an informational statement that Wal-Mart is selling certain goods that are made or assembled in America, and would not be perceived as a service mark.

Although the evidence of Wal-Mart’s own usage was sufficient to establish that the phrase does not function as a mark, the Board also considered use of the phrase by third parties. The examining attorney submitted many examples showing that “investing in American jobs” is commonly used in several industries to convey the same general idea (supporting American jobs) as does Wal-Mart. This evidence further demonstrated that the public perceives the phrase as merely informational.

Wal-Mart pointed to search engine results, advertising expenditures of more than \$10 million, attendance of 5,700 people at promotional events featuring the slogan, and more than 300,000 visits to its website, as evidence that the phrase is recognized as a mark. Wal-Mart also criticized the USPTO’s evidence as failing to show how many visits third-party websites had received. The Board was unimpressed.

[T]here is no requirement that the Examining Attorney establish that a particular online source or website “has significant web traffic” to establish its competence, just as

¹⁸³ *Wal-Mart Stores*, 129 U.S.P.Q.2d at 1150.

¹⁸⁴ *Id.* at 1152.

¹⁸⁵ *Id.*

with print articles, the Examining Attorney need not establish the circulation of the magazine or newspaper or that the cited article has actually been read Even websites that are not frequently visited still demonstrate how the authors use the term or phrase and how that term or phrase will be perceived by the readers.¹⁸⁶

The Board found that the third-party evidence “shows common usage of the phrase ‘investing in American jobs’ by commercial businesses in various industries, as well as in media articles and blogs, to convey the goal or aim of investing in U.S. business to promote employment opportunities in America.”¹⁸⁷

None of Wal-Mart’s evidence demonstrated that the claimed mark serves as a source indicator. The number of searches and the ranking in search results reveal nothing about the impression that the phrase makes on consumers. The evidence of corporate promotional expenditures, attendance at events, and website traffic statistics “fares no better.”¹⁸⁸

In sum, the USPTO’s third-party evidence supported the Board’s conclusion that consumers will not perceive INVESTING IN AMERICAN JOBS as an indicator of a single source for the identified services. “Rather, consumers will perceive the words merely as conveying the common, informational message that Applicant, like others, promotes American-made goods by investing in American jobs.”¹⁸⁹

The Board accordingly affirmed the refusal to register under Sections 1, 2, 3, and 45 of the Lanham Act.

In re DePorter

In another failure-to-function ruling, the Board affirmed a refusal to register the rather obscure term #MAGICNUMBER108 as a trademark for shirts. The Board concluded that the term conveys an informational message referring to the Chicago Cubs winning the World Series in 2016 after a 108-year drought and does not serve as a source identifier.¹⁹⁰

The examining attorney submitted evidence showing that numerous third parties have used #MAGICNUMBER108 as part of messages posted on social media during and after the 2016 World Series, expressing support for the historically hapless Cubbies. There was no dispute that Applicant DePorter—who may be the

¹⁸⁶ *Id.* at 1156-57.

¹⁸⁷ *Id.* at 1157.

¹⁸⁸ *Id.* at 1158.

¹⁸⁹ *Id.* at 1159.

¹⁹⁰ *In re DePorter*, 129 U.S.P.Q.2d 1298 (T.T.A.B. 2019).

World’s leading expert in Cubs numerology—was the first to use the term.

The Board found that the USPTO’s evidence showed “wide use of the proposed mark in a non-trademark manner to consistently convey information about the Chicago Cubs’ World Series appearance and win after a 108-year drought.”¹⁹¹ There is no requirement that the evidence show the term used for goods in commerce. “This evidence is competent to suggest that upon encountering Applicant’s ‘mark,’ prospective purchasers familiar with such widespread non-trademark use are unlikely to consider it to indicate the source of Applicant’s goods.”¹⁹²

The presence of the hash mark in the applicant’s proposed mark reinforced the Board’s finding.

In the social media context, a hashtag “is a word or phrase preceded by a hash mark (#), used within a message to identify a keyword or topic of interest and facilitate a search for it.” Evidence in the record establishes that Applicant’s proposed mark #MAGICNUMBER108 has been used extensively as a hashtag to identify the Chicago Cubs’ World Series appearance and win.¹⁹³

The Board observed that a hashtag, when used as part of an online social media search term, generally serves no source-identifying function. It “merely facilitate[s] categorization and searching within online social media.”¹⁹⁴ “Therefore, the addition of the term HASHTAG or the hash symbol (#) to an otherwise unregistrable term typically will not render the resulting composite term registrable.”¹⁹⁵

Applicant DePorter argued that #MAGICNUMBER108 has never been used in everyday speech, and instead is arbitrary and fanciful. The Board pointed out, however, that even if true, that does not necessarily mean the public perceives the term as a source indicator. Here, the evidence established that the proposed mark is a “widely-used message to convey information about the Chicago Cubs baseball team.”¹⁹⁶

The Board concluded that “#MAGICNUMBER108 is perceived as part of an online social media trend related to the phrase ‘magic number 108,’ expressing affiliation with the Chicago Cubs baseball team and their 2016 World Series win after 108 years, rather than

¹⁹¹ *Id.* at 1302.

¹⁹² *Id.*

¹⁹³ *Id.* at 1302-03.

¹⁹⁴ *Id.* at 1303, quoting TMEP § 1202.18 (2017).

¹⁹⁵ *Id.*

¹⁹⁶ *Id.*

as an identification of source for the goods identified in the application.”¹⁹⁷

In re TracFone Wireless, Inc.

In yet another failure-to-function decision, the Board affirmed the USPTO’s refusal to register the term UNLIMITED CARRYOVER for telecommunication services, finding that the phrase, as displayed on the applicant’s specimen of use, will be seen as an informational message and not as a source indicator.¹⁹⁸

The Board observed once again that the critical question in determining whether a purported mark serves to indicate source is whether the term would be perceived as a mark by relevant consumers. To make that determination, one must look to how the term is actually used in the marketplace.¹⁹⁹

The examining attorney contended that, as displayed on the specimen of use, UNLIMITED CARRYOVER does not identify the source of the services and distinguish them from others, because of the placement of the phrase on the specimen and because the phrase is informational and common. The Board agreed.

[T]he wording UNLIMITED CARRYOVER is last in a list of apparent features of Applicant’s “No-Contract Plans with Talk, Text, Data and Unlimited Carryover® starting at \$15.” The phrase is set in the midst of other clearly informational matter, far from the TRACFONE logo. This suggests that UNLIMITED CARRYOVER too is informational matter.²⁰⁰

The Board saw nothing in the specimen to suggest that “Unlimited Carryover” identifies the source of telecommunications services, “any more than the other listed components of Applicant’s plans: ‘Talk,’ ‘Text,’ and ‘Data.’”²⁰¹ Instead, the phrase “will be perceived as part of the services rather than as a mark designating the source of the services.”²⁰²

The Board observed that the inherent nature of the phrase is merely informational. Several examples of use of the term “carryover” by Applicant TracFone and by a third party supported a finding that UNLIMITED CARRYOVER “will be seen as merely an informational slogan which conveys information about carrying over

¹⁹⁷ *Id.* at 1304.

¹⁹⁸ *In re TracFone Wireless, Inc.*, 2019 U.S.P.Q.2d 222983 (T.T.A.B. 2019).

¹⁹⁹ *Id.* at *3. *See In re Eagle Crest* 96 U.S.P.Q.2d at 1229.

²⁰⁰ *Id.* at *5. *See, e.g., In re AOP LLC*, 107 U.S.P.Q.2d 1644, 1654 (T.T.A.B. 2013).

²⁰¹ *Id.*

²⁰² *Id.*

unlimited data from one telecommunications billing cycle to the next rather than as a service mark.”²⁰³

While the record may not support a finding that UNLIMITED CARRYOVER is a widely used phrase, it does support a finding that the meaning of the phrase simply provides information about the services, and Applicant’s manner of use underscores and illustrates that meaning, and how it would be perceived by consumers as such.²⁰⁴

TracFone pointed to its ownership of a registration on the Supplemental Register for the same mark for essentially the same services. The specimen for that registration is identical to the specimen here. The Board was not impressed. “The specimens for the registration on the Supplemental Register are not of record, and Applicant’s argument is circular. The registration also is more than eight years old; consumer perception of UNLIMITED CARRYOVER may have changed with the passage of time.”²⁰⁵

The Board further observed that each case must be decided on its own merits.

The Board must make its own findings of fact, and that duty may not be delegated by adopting the conclusions reached by an examining attorney in another application. *In re Sunmarks, Inc.*, 32 U.S.P.Q.2d 1470, 1472 (T.T.A.B. 1994); *In re BankAmerica Corp.*, 231 U.S.P.Q. 873, 876 (T.T.A.B. 1986). This is particularly the case when the prior registration is nearly a decade old and involves the rapidly evolving field of telecommunications.²⁰⁶

Further, an applicant may not resort to Section 2(f) to register a term that does not identify source and is merely informational; such a term does not meet the statutory definition of a mark and is therefore unregistrable.²⁰⁷

Considering the entire record, the Board found that TracFone’s specimen of use was insufficient to show use of UNLIMITED CARRYOVER as a service mark for the identified services.

²⁰³ *Id.* at *8. *See, e.g., In re Standard Oil Co.*, 275 F.2d 945, 125 U.S.P.Q. 227 (C.C.P.A. 1960) (finding GUARANTEED STARTING to be ordinary words conveying information about the services, not a service mark for “winterizing” motor vehicles).

²⁰⁴ *Id.* at *8-9.

²⁰⁵ *Id.* at *9.

²⁰⁶ *Id.* at *9-10.

²⁰⁷ *Id.* at *10. Contrast this with matter that is “merely ornamental.” In that case, an applicant may resort to Section 2(f) to establish acquired distinctiveness.

6. Phantom Mark

In re Society of Health and Physical Educators

Under the Lanham Act, “a trademark application may only seek to register a *single* mark.”²⁰⁸ A mark that contains a changeable or phantom element resulting in more than one mark must be refused registration.²⁰⁹ Accordingly, the Board affirmed a refusal to register SHAPE XXXX for educational publications and services, finding that the term is a phantom mark that comprises more than one mark.

A miscellaneous statement in the subject application indicated that “[t]he ‘XXXX’ in the mark denotes the unabbreviated name of a state of the United States and Puerto Rico.” The crux of the issue, then, was whether all permutations of SHAPE XXXX legally constitute “one mark.”²¹⁰

One reason for this “one-mark-per-application” rule is that a trademark registration must provide adequate notice of the scope of the registration to potential users of the same or a similar mark.²¹¹ Whether a changeable element is permissible depends on whether the various possibilities represent a single mark.²¹²

In *International Flavors & Fragrances*, the CAFC found that the mark LIVING XXXX FLAVORS violated the one-mark-per-application requirement “because the variable element encompassed too many combinations and permutations to make constructive notice meaningful.”²¹³ The application stated that the variable element “XXXX” “indicated ‘a botanical or extract thereof, to wit: ‘flower’, ‘fruit’, ‘yellow sunset orchard’, ‘osmanthus’, ‘fragrance’, ‘raspberry’ and the like.”²¹⁴ More recently, in *In re Construction Research & Technology GmbH*, the TTAB deemed the marks NP - - - and SL - - -, in which the variable element “represents up to three numeric digits,” to be phantom marks, in part because the possible range of meanings that could arise from the digits was unclear.²¹⁵

In contrast, the CAFC found the mark 1-888-M-A-T-R-E-S-S for “telephone shop-at-home retail services in the field of mattresses” to

²⁰⁸ *In re Int’l Flavors & Fragrances, Inc.*, 183 F.3d 1361, 51 U.S.P.Q.2d 1513, 1516 (Fed. Cir. 1999).

²⁰⁹ *In re Primo Water Corp.*, 87 U.S.P.Q.2d 1376, 1378 (T.T.A.B. 2008).

²¹⁰ *In re Soc’y of Health and Physical Educators*, 127 U.S.P.Q.2d 1584 (T.T.A.B. 2018).

²¹¹ *Id.* at 1585-86, citing *Int’l Flavors & Fragrances*, 51 U.S.P.Q.2d at 1517-18 (“The registration of such [phantom] marks does not provide proper notice to other trademark users, thus failing to help bring order to the marketplace and defeating one of the vital purposes of federal trademark registration.”).

²¹² *Id.* at 1586, citing *Int’l Flavors & Fragrances*, 51 U.S.P.Q.2d at 1517.

²¹³ *Id.*

²¹⁴ *Id.*

²¹⁵ 122 U.S.P.Q.2d 1583, 1585 (T.T.A.B. 2017).

be the legal equivalent of the mark (212) M-A-T-T-R-E-S, in which the term (212) was defined as a changeable element. The court there held that “it is apparent . . . that the missing information in the mark is an area code, the possibilities of which are limited by the offerings of the telephone company.”²¹⁶ And in a case involving the mark 1-800-MATTRESS (the numerals representing a changeable area code), the Board reversed a phantom mark refusal, stating “[i]t is immediately apparent that the phantom portion consists of a three-number combination which is an area code. There is no ambiguity. It is a telephone mnemonic.”²¹⁷

Together, these decisions teach that when an applicant seeks to register a mark with a variable element, we must decide whether the permutations of the variable element affect the commercial impression so as to result in more than one mark. Put differently, if such a mark is to be registered, the possible variations of the mark must be legal equivalents. See *Dial-A-Mattress I*, 57 U.S.P.Q.2d at 1813 (“Although the registration of the ‘(212) M-A-T-R-E-S-S’ mark is a ‘phantom’ mark, . . . ‘1-888-M-A-TR-E-S-S’ is the legal equivalent of the ‘(212) M-A-T-T-R-E-S-S’ mark.”); *Dial-A-Mattress II*, . . . 2004 WL at 1427di390, *4 [sic] (1- --- --- --- -MATTRESS was approved for registration because, *inter alia*, the different variations of the mark were legal equivalents).²¹⁸

Here, the applied-for mark is capable of 51 variations. Although the scope or definition of the variable element is specified in a “miscellaneous statement” in the application at issue,²¹⁹ the applicant’s statement “only confirms that this application is not for a single mark and that this variation would inhibit effective searching because the 51 geographic locations are not listed in any searchable portion of the application.”²²⁰ “The crux of the issue, however, is whether all permutations of SHAPE XXXX, where XXXX is a state name or Puerto Rico, may be considered to be one mark (*e.g.*, whether SHAPE MICHIGAN is the same mark as SHAPE OHIO).”²²¹

²¹⁶ *In re Dial-A-Mattress Operating Corp.*, 240 F.3d 1341, 57 U.S.P.Q.2d 1807, 1813 (Fed. Cir. 2001) (“*Dial-A-Mattress I*”).

²¹⁷ *In re Dial-A-Mattress Operating Corp.*, Serial No. 76290744, 2004 WL 1427390, at *3 (T.T.A.B. June 15, 2004) (“*Dial-A-Mattress II*”).

²¹⁸ *Soc’y of Health and Physical Educators*, 127 U.S.P.Q.2d at 1587.

²¹⁹ See generally, TMEP § 808, entitled “Description of Mark.”

²²⁰ *Soc’y of Health and Physical Educators*, 127 U.S.P.Q.2d at 1588. The Board noted that even if the 51 locations were stated in the description of the mark, that field “is not generally searched when looking for similar marks.” *Id.* at n.8.

²²¹ *Id.*

Two marks are the “same mark” if they are legal equivalents.²²² “A mark is the legal equivalent of another if it creates the same, continuing commercial impression such that the consumer would consider them both the same mark. Whether marks are legal equivalents is a question of law”²²³ There is no need to consider evidence other than the visual or aural appearance of the marks themselves.²²⁴

[I]n a phantom mark in which the changeable elements are arbitrary or fanciful, it is correspondingly likely that the various permutations of the mark will result in different commercial impressions and therefore constitute different marks. In contrast, where the changeable elements are generic or merely descriptive, it is conceivable that the permutations of the mark may constitute a single mark. However, there can be no hard and fast rule, because even generic and descriptive matter may contribute to the commercial impression of a mark in certain circumstances.²²⁵

The Board found that SHAPE XXXX is not one mark because the different permutations thereof are not legal equivalents.

Even though geographic terms are generally considered not to be inherently distinctive, they are capable of acquiring distinctiveness . . . [Thus, f]or example, SHAPE MICHIGAN signifies educational services emanating from Michigan while SHAPE OHIO signifies educational services emanating from OHIO. The distinction is important in this case where geographic terms are capable of acquiring distinctiveness, which would further distinguish the marks.²²⁶

Each variation of SHAPE XXX would have a different appearance and pronunciation. The range of variation is “undoubtedly broader” than that of the three-digit variable area code of the *Dial-A-Mattress* cases.²²⁷ Although there may be more area codes than the number of states plus Puerto Rico, “the area codes were not only numerical and fixed in length, but also were part of a telephone number mnemonic, and so varied less in

²²² *Id.*

²²³ *Id.*, quoting *Dial-A-Mattress I*, 57 U.S.P.Q.2d at 1812 (citing *Van Dyne-Crotty, Inc. v. Wear-Guard Corp.*, 926 F.2d 1156, 17 U.S.P.Q.2d 1866, 1868 (Fed. Cir. 1991) (to be legal equivalents, “the marks must create ‘the same, continuing commercial impression’”).

²²⁴ *Id.*

²²⁵ *Id.* at 1587.

²²⁶ *Id.* at 1588-89.

²²⁷ *Id.* at 1590.

appearance and pronunciation. *See, e.g., Dial-A-Mattress II, . . .* 2004 WL 1427390, at *3.”²²⁸

The Board also noted the applicant’s concession that it had not yet used SHAPE XXXX with all 51 variations of state names and Puerto Rico. “This emphasizes the problem with Applicant’s phantom mark application, as it has filed a use-based application where all the variations of the changeable element are not in use.”²²⁹

Concluding that SHAPE XXXX constitutes more than one mark, the Board affirmed the refusal to register.

7. Unacceptable Specimen of Use

In re The Cardio Group, LLC

Finding that the specimens of use failed to associate the mark THE CARDIO GROUP & Design with the identified services, the Board affirmed a refusal to register the mark for “retail store services featuring medical devices.” Although the applicant is engaged in selling products, “nothing in the documents submitted by Applicant . . . refer to a retail store (of either the on-line or brick-and-mortar variety) or create an association of any kind between THE CARDIO GROUP and design and a retail store service.”²³⁰

The question, as set forth by the Board, was “whether the evidence of Applicant’s use of its mark creates an association between the mark and Applicant’s retail store services.”²³¹

Specimens showing the mark used in rendering the identified services need not explicitly refer to those services in order to establish the requisite direct association between the mark and the services, but “there must be something which creates in the mind of the purchaser an association between the mark and the service activity.” *In re Way Media*, 118 U.S.P.Q.2d 1697, 1698 (T.T.A.B. 2016) (quoting *In re Johnson Controls, Inc.*, 33 U.S.P.Q.2d 1318, 1320 (T.T.A.B. 1994)).²³²

To create such a “direct association,” the specimen must both contain a reference to the service and identify the service and its source.²³³

Applicant Cardio Group submitted a website screenshot, a confidential sales agreement, and an invoice, all displaying the

²²⁸ *Id.*

²²⁹ *Id.*

²³⁰ *In re The Cardio Group, LLC*, 2019 U.S.P.Q.2d 227232, *11 (T.T.A.B. 2019).

²³¹ *Id.* at *6, citing *In re JobDiva, Inc.*, 843 F.3d 936, 121 U.S.P.Q.2d 1122, 1126 (Fed. Cir. 2016) (citation omitted).

²³² *Id.*

²³³ *Id.* *See In re Way Media*, 118 U.S.P.Q.2d 1697, 1698 (T.T.A.B. 2016) (quoting *In re Osmotica Holdings Corp.*, 95 U.S.P.Q.2d 1666, 1668 (T.T.A.B. 2010)).

subject mark. However, the website specimen presented the results of an analysis from a medical device but did not refer to any retail store services.²³⁴ The sales agreement did not indicate how the sale was made (i.e., whether through a retail store or personal sales call or otherwise). And the invoice likewise did not refer to any activity that might be considered a retail store service.

While the two documents may evidence a November 2, 2015, transaction involving the sale of a medical device, they do not reveal, for example, how the goods were, if at all, advertised, brought to the attention of, or sold to a customer. Thus they do not evidence advertising that the goods were available via retail store services. More generally, these documents reflect product sales. They do not indicate that any service, in any form, was provided.²³⁵

In assessing the adequacy of specimens, the USPTO must consider any explanations offered by an applicant that clarify “the nature, content, or context of use of the specimen that are consistent with what the specimen itself shows.”²³⁶ Cardio Group asserted that its services are in the nature of activities provided by a retail store—i.e., selling goods—and it argued that such activities do not have to take place in an actual retail store.²³⁷ The Board, however, found that this explanation did not clarify the matter.

Cardio Group also tried to amend its description of services to retail sales services, rather than retail store services, but the examining attorney refused to enter the amendment, contending that it would improperly broaden the scope of the services. The Board found that the proposed change simply restated that the applicant’s specimens “reflect a product sale” and not that any retail store services were provided.²³⁸

Considering all the specimens along with the applicant’s explanations, the Board found “no direct association in any of the

²³⁴ *Id.* at *7, n.5.

“Retail store services are considered a service under the Nice Agreement because the activities of a retail establishment that surround the sale of goods do provide a benefit to others, e.g., the bringing together, for the benefit of others, a variety of goods (excluding the transport thereof), enabling customers to conveniently view and purchase those goods.” Retail Store Services Note 035-1089 in the Acceptable Identification of Goods and Services Manual.

²³⁵ *Id.* at *7-8.

²³⁶ *Id.* at *8. See *In re Pitney Bowes, Inc.*, 125 U.S.P.Q.2d 1417, 1420 (T.T.A.B. 2018); *In re DSM Pharms., Inc.*, 87 U.S.P.Q.2d 1623, 1626 (T.T.A.B. 2008) (“In determining whether a specimen is acceptable evidence of service mark use, we may consider applicant’s explanations as to how the specimen is used, along with any other available evidence in the record that shows how the mark is actually used.”).

²³⁷ The Board noted that “[r]etail stores services may be offered in various ways, such as through physical locations (‘brick and mortar’), catalogs or online. Applicant’s specimens do not suggest any of these.” *Id.* *9, n.8.

²³⁸ *Id.* at *10.

specimens between THE CARDIO GROUP and design and any type of retail store service.”²³⁹

Nothing in these documents demonstrates that consumers would perceive THE CARDIO GROUP and design as a source indicator for retail store services. Ultimate consumers who choose to purchase Applicant’s products very well may understand they are engaging in a retail sales transaction with Applicant, but even if this is assumed, it would not establish that such consumers, prior to making their decision to make such a purchase, were exposed to any advertising or promotion of Applicant as the operator of a retail store selling medical devices.²⁴⁰

And so, the Board affirmed the refusal under Sections 1 and 45 of the Lanham Act.

8. Genericness

In re Virtual Independent Paralegals, LLC

One might consider the “genericness” refusal to register as another form of refusal for “failure-to-function” as a source indicator. Here, the Board affirmed two refusals to register VIRTUAL INDEPENDENT PARALEGALS for “paralegal services; providing medical record summaries, deposition summaries and document review; litigation support services” [PARALEGALS disclaimed], finding the phrase to be generic for, or alternatively merely descriptive of, the identified services.²⁴¹ The Board concluded that the proposed mark “identifies a class of paralegals who telecommute or work remotely.”²⁴² As to the Section 2(e)(1) refusal, the Board rejected as insufficient the applicant’s claim of acquired distinctiveness based solely on its declaration of five years of continuous and substantially exclusive use.

As usual, the Board found the genus of services to be defined by the applicant’s recitation of services.²⁴³ The relevant consuming public is not confined to professionals, but includes the general public, namely, “ordinary consumers who need assistance completing forms.”²⁴⁴

²³⁹ *Id.* at *11.

²⁴⁰ *Id.*

²⁴¹ *In re Virtual Indep. Paralegals, LLC*, 2019 U.S.P.Q.2d 111512 (T.T.A.B. 2019).

²⁴² *Id.* at *17.

²⁴³ *Id.* at *5. *See In re Reed Elsevier Props. Inc.*, 482 F.3d 1376, 82 U.S.P.Q.2d 1378, 1380 (Fed. Cir. 2007); *Magic Wand Inc. v. RDB Inc.*, 940 F.2d 638, 19 U.S.P.Q.2d 1551, 1552 (Fed. Cir. 1991) (“[A] proper genericness inquiry focuses on the description of [goods or] services set forth in the [application or] certificate of registration.”).

²⁴⁴ *Id.* at *8.

The examining attorney submitted numerous Internet excerpts identifying “virtual paralegal” as a class of paralegals who telecommute or work remotely. Other website evidence established that “independent paralegal” identifies a class of paralegals that operate without attorney supervision.

Assessing the proposed mark as a whole, the Board found it to be “indisputably generic.”²⁴⁵ “Combining VIRTUAL PARALEGAL and INDEPENDENT PARALEGAL into VIRTUAL INDEPENDENT PARALEGALS provides no additional or changed meaning.”²⁴⁶ The Board’s conclusion was corroborated by two examples of the terms “VIRTUAL,” “INDEPENDENT,” and “PARALEGAL” used in connection with legal services, although not in the same order as the phrase at issue. “Thus, the record shows that VIRTUAL INDEPENDENT PARALEGALS will be used by competitors and understood by the relevant public primarily as referring to the class of paralegals who work remotely without attorney supervision either for themselves or on behalf of an attorney.”²⁴⁷

For completeness, the Board also considered the Section 2(e)(1) mere descriptiveness refusal. The applicant sought registration based on acquired distinctiveness under Section 2(f), relying only on its claim of continuous and substantially exclusive use for “at least five years.”²⁴⁸ This resort to Section 2(f) amounted to a concession that the proposed mark is “merely descriptive.”²⁴⁹

Based on the evidence regarding genericness, the Board concluded that each of the terms comprising the applicant’s proposed mark is highly descriptive of its services. When the terms are combined, the resulting phrase is “at the very least, highly descriptive of those services.”²⁵⁰ Consequently, the applicant’s burden to prove acquired distinctiveness is “commensurately high.”²⁵¹

The Board found that the applicant’s claim of five years of use fell short.

Because, for purposes of this section, we are assuming that VIRTUAL INDEPENDENT PARALEGALS—which we

²⁴⁵ *Id.* at *17.

²⁴⁶ *Id.* at *18.

²⁴⁷ *Id.* at *20.

²⁴⁸ *Id.* at *22.

²⁴⁹ *Id.* Perhaps the better view is that the applicant conceded that the mark is not inherently distinctive, rather than merely descriptive. See *In re Am. Furniture Warehouse Co.*, 126 U.S.P.Q.2d 1400, 1403 (T.T.A.B. 2018) (noting that a claim of acquired distinctiveness by applicant to overcome a refusal in a prior registration for the same wording in connection with same services “can be viewed as a concession by Applicant that the wording itself is not inherently distinctive for those services”).

²⁵⁰ *Id.* at *24.

²⁵¹ *Id.* at *25.

found to be generic—is, at very best, highly descriptive, we find that five years of substantially exclusive and continuous use is not sufficient to prove that VIRTUAL INDEPENDENT PARALEGALS has acquired distinctiveness. *See La. Fish Fry Prods., Ltd.*, 797 F.3d 1332, 116 U.S.P.Q.2d 1264, 1265 (Fed. Cir. 2015) (Board has discretion not to accept an applicant’s allegation of five years of substantially exclusive and continuous use as prima facie evidence of acquired distinctiveness when the proposed mark is “highly descriptive”).²⁵²

In re Hikari Sales USA, Inc.

Adding to an expanding list of genericness rulings, the Board affirmed a refusal to register ALGAE WAFERS for “fish food,” finding it to be generic for the goods. The Board also affirmed an alternative refusal under Section 2(e)(1), deeming Applicant Hikari’s proof of acquired distinctiveness under Section 2(f) to be inadequate in view of the highly descriptive nature of the term.²⁵³

Genericness: The question of whether a proposed mark is generic is determined by its primary significance to the relevant public.²⁵⁴ As usual, there was no dispute here as to the genus of goods, which the Board found to be congruent with the applicant’s identification, i.e., “fish food.”²⁵⁵ The relevant public comprises consumers who use or purchase fish food, i.e., plant or animal material for consumption by fish kept in aquariums or ponds.

The record evidence bearing on the public’s understanding of “Algae Wafers” included dictionary definitions of the constituent terms; Applicant Hikari’s specimen of use depicting the goods in wafer or disk form, stating “Ideal for Algae Eaters” and indicating that the goods include spirulina (a microalgae) as an ingredient; Hikari’s brochure referring to the goods as a “sinking wafer;” examples of use of the term by competitors; third-party Internet evidence referring to fish food for algae-eating fish; use of the term in books and news stories; Google search results; Hikari’s policing efforts; Hikari’s survey results; and testimony from Hikari’s linguistic expert.

Hikari pointed to its commencement of four infringement suits against competitors, two of whom no longer use the term “algae disks” with their products. The Board gave this evidence no weight, since the competitors may have agreed to discontinue use of the

²⁵² *Id.*

²⁵³ *In re Hikari Sales USA, Inc.*, 2019 U.S.P.Q.2d 111514 (T.T.A.B. 2019).

²⁵⁴ *Id.* at *5, citing *Magic Wand*, 19 U.S.P.Q.2d at 1553-54; *H. Marvin Ginn Corp. v. Int’l Ass’n of Fire Chiefs, Inc.*, 782 F.2d 987, 228 U.S.P.Q. 528, 530 (Fed. Cir. 1986)).

²⁵⁵ *Id.* *See Magic Wand*, 19 U.S.P.Q.2d at 1552 (a proper genericness inquiry focuses on the identification set forth in the application or registration).

term in order to avoid litigation rather than because they considered the term distinctive.²⁵⁶

Turning to Hikari’s survey evidence, the Board pointed out that, like various circuit courts of appeals, it has found that as to genericness, consumer surveys “are only appropriate to consider in a case where the question is whether a coined or arbitrary mark has become generic, and is not appropriate to prove recognition of an otherwise not inherently distinctive mark.”²⁵⁷

There are two types of generic terms: those that name the product or service in ordinary English, and those that originated as distinctive brand names but became generic over time. Only in the latter case are consumer surveys relevant. Surveys might help in determining whether a designation that started life as a mark now is understood to be the thing itself, but they can have no probative value where the issue is the meaning of terms as a lexical matter. Where, as here, the question is not whether a term has become generic through common use, consumer surveys are not relevant.²⁵⁸

The Board observed, however, that even if the survey evidence were considered, it was entitled to little weight due to numerous flaws in the survey itself and in Hikari’s interpretation thereof. Hikari claimed a recognition rate of more than 50% in arguing that ALGAE WAFERS is not generic and has secondary meaning. The Board noted, however, that more than 47% of the 1,001 respondents that identified “Algae Wafers” with multiple sources named someone other than Hikari.

Moreover, the survey also did not utilize a control group and no pre-testing was performed. Therefore, the Board could not be sure that survey participants actually understood what they were being asked.

The survey asked consumers whether they “associated” the term “Algae Wafers” with one or more companies. But the

²⁵⁶ *Id.* at *24. See *In re Volvo White Truck Corp.*, 16 U.S.P.Q.2d 1417, 1421 (T.T.A.B. 1990) (recognizing that a competitor may stop using a term to avoid a costly lawsuit rather than because it considers the term to be a trademark, particularly if there were other terms it could use); *In re Consolidated Cigar Corp.*, 13 U.S.P.Q.2d 1481, 1483 (T.T.A.B. 1989) (evidence that competitors agreed to discontinue use showed merely a desire to avoid litigation rather than acknowledgement of distinctiveness of the term “whiffs”).

²⁵⁷ *Id.* at *26-27, citing *Frito-Lay N. Am., Inc. v. Princeton Vanguard, LLC*, 124 U.S.P.Q.2d 1184, 1196 (T.T.A.B. 2017); *Miller Brewing Co. v. Jos. Schlitz Brewing Co.*, 605 F.2d 990, 203 U.S.P.Q. 642, 647 (7th Cir. 1979); *Schwan’s IP, LLC v. Kraft Pizza Co.*, 460 F.3d 971, 79 U.S.P.Q.2d 1790, 1794 (8th Cir. 2006); see also *National Nonwovens, Inc. v. Consumer Prods. Enters., Inc.*, 397 F. Supp. 2d 245, 78 U.S.P.Q.2d 1526, 1533 (D. Mass. 2005) (citing *Hunt Masters, Inc. v. Landry’s Seafood Restaurants, Inc.*, 57 U.S.P.Q.2d 1884, 1886 (4th Cir. 2001)).

²⁵⁸ *Id.* at *27, quoting *Frito-Lay*, 124 U.S.P.Q.2d at 1196; accord *Hunt Masters*, 57 U.S.P.Q.2d at 1886.

survey does not adequately reveal the nature of the association a consumer perceives between “Algae Wafers” and Applicant Hikari and the other companies identified, as there were no follow-up questions inquiring as to the reason for identifying Hikari, or another company that would establish what the respondent understood.²⁵⁹

The survey also did not explore the proper universe. Although the goods were broadly identified as “fish food,” the survey respondents were limited to purchasers of fish food for tropical fish in households where tropical fish are owned, and it did not include those who purchase fish food for fish other than tropical fish.²⁶⁰ Also, the survey may have been skewed towards Hikari by excluding respondents who had not seen the term “Algae Wafers” on any food products for tropical fish but owned or cared for tropical fish and purchased food.

Turning to the analysis of the term ALGAE WAFERS by Hikari’s linguistic expert, the Board found that evidence to be useless:

We do not know the sources he used to support his conclusions regarding the meaning of “wafer.” But in his analysis of the term “algae,” Dr. Habick focuses on the ingredient in a wafer that is for human consumption, rather than considering algae as an ingredient in connection with fish food, the relevant goods. . . . Dr. Habick did not explain why he did not consider in his analysis other definitions or meanings for “wafer,” including those referencing a disc shape. Dr. Habick also did not consider Applicant’s own advertising and promotional materials which describe the goods as having a disc shape, containing algae, and for algae eaters; nor did Dr. Habick consider any third-party use. Moreover, there is no evidence suggesting that Dr. Habick is a trademark expert, and his opinion as to whether “Algae Wafers” is suggestive, descriptive or generic is not entitled to any weight.²⁶¹

Finding that ALGAE WAFERS “has a plain and readily understood meaning as a type of fish food in wafer form containing algae,” the Board deemed the term generic and thus ineligible for trademark registration.²⁶²

²⁵⁹ *Id.* at *29-30.

²⁶⁰ *Id.* at *30. *See Omaha Steaks Int’l, Inc. v. Greater Omaha Packing Co.*, 908 F.3d 1315, 128 U.S.P.Q.2d 1686, 1692 (Fed. Cir. 2018) (where identification of goods broadly identified goods as meat and beef, survey universe was too narrow because it eliminated from the survey meat eaters who buy their meat from sources other than plaintiff).

²⁶¹ *Id.* at *25-26.

²⁶² *Id.* at *33.

Acquired Distinctiveness: For completeness, the Board considered Hikari's claim of acquired distinctiveness. Not surprisingly in light of the record evidence and its finding of genericness, the Board found ALGAE WAFERS to be highly descriptive of fish food. Therefore, Hikari had a correspondingly higher burden of proof under Section 2(f).

Applying the CAFC's *Converse* factors,²⁶³ the Board observed again that Hikari's survey carried little probative weight because of its several deficiencies and concluded that the opinion of its linguistics expert that ALGAE WAFERS had acquired distinctiveness was likewise of little evidentiary value.

Hikari had used the term "Algae Wafers" since 1991 and spent some \$95,000 per year on print and Internet advertising, but the record lacked "sufficient information as to whether the amounts stated are significant in the industry."²⁶⁴ Moreover, its advertisements also featured other Hikari products sold under other brand names, "thus diluting how much of the advertising spending should be counted toward building consumer awareness of 'Algae Wafers.'"²⁶⁵ Hikari's trade show expenditures averaged about \$80,000 per year, but it was unclear how much of the advertising and trade show expenses were related to products sold under the "Algae Wafers" designation. There was no information of record as to the circulation of the magazines in which Hikari advertised, and no information as to the number of visitors at its trade show booths. Consequently, there was nothing to indicate "the extent of consumer exposure and any resulting impact on consumer perception."²⁶⁶

The Board concluded that, "[g]iven that the designation is highly descriptive, much more persuasive evidence than Applicant has submitted would be necessary to show that 'Algae Wafers' has become distinctive as a source indicator for Applicant's fish food."²⁶⁷

And so, the Board affirmed the alternative refusal to register on the ground of mere descriptiveness and lack of acquired distinctiveness.

²⁶³ 128 U.S.P.Q.2d at 1546:

[T]he considerations to be assessed in determining whether a mark has acquired secondary meaning can be described by the following six factors: (1) association of the trade dress with a particular source by actual purchasers (typically measured by customer surveys); (2) length, degree, and exclusivity of use; (3) amount and manner of advertising; (4) amount of sales and number of customers; (5) intentional copying; and (6) unsolicited media coverage of the product embodying the mark.

²⁶⁴ *Hikari Sales USA*, 2019 U.S.P.Q.2d 111514 at *42.

²⁶⁵ *Id.* at *43.

²⁶⁶ *Id.* at *44.

²⁶⁷ *Id.* at *45.

In re Katch, LLC

The Board rendered a split decision in this enervating appeal from a genericness refusal of the proposed mark HEALTHPLANS.COM (in standard character form) for advertising services in the field of medical and life insurance (International Class 35) and for online software services for tracking, administration, billing, and reporting of advertising (International Class 42). The Board affirmed the Class 35 refusal under Section 23(c)²⁶⁸ but reversed the Class 42 refusal.²⁶⁹

Applicant Katch sought registration on the Supplemental Register. The Board observed that “[i]n order to qualify for registration on the Supplemental Register, a proposed mark ‘must be capable of distinguishing the applicant’s goods or services.’”²⁷⁰ Generic terms do not qualify for such registration because “by definition [they] are incapable of indicating a unique source.”²⁷¹

In *Marvin Ginn*,²⁷² the CAFC formulated a two-step inquiry to determine whether a term is generic: “First, what is the genus (category or class) of goods or services at issue? Second, is the term sought to be registered understood by the relevant public primarily to refer to that genus of goods or services?”²⁷³ “The relevant public’s perception is the chief consideration in determining whether a term is generic.”²⁷⁴ “[A] term can be generic for a genus of goods or services if the relevant public . . . understands the term to refer to a key aspect of that genus.”²⁷⁵ As to the first step of the *Marvin Ginn* test, the genus may be defined by the services identified in the application.²⁷⁶

Class 35: For the Class 35 services, the application, and thus the genus, includes “Insurance lead collection and matching services,

²⁶⁸ Section 23(c) of the Lanham Act, 15 U.S.C. § 1091(c), permits registration on the Supplemental Register of a mark that “may consist of any . . . configuration of goods . . . that as a whole is not functional . . . but such mark must be capable of distinguishing the applicant’s goods or services.”

²⁶⁹ *In re Katch, LLC*, 2019 U.S.P.Q.2d 233842 (T.T.A.B. 2019).

²⁷⁰ *Id.* at *4, quoting *In re Emergency Alert Sols. Grp., LLC*, 122 U.S.P.Q.2d 1088, 1089 (T.T.A.B. 2017) (quoting 15 U.S.C. § 1091(c)).

²⁷¹ *Id.*, quoting *La. Fish Fry*, 116 U.S.P.Q.2d at 1267 (citing *In re Merrill Lynch, Pierce, Fenner, & Smith, Inc.*, 828 F.2d 1567, 4 U.S.P.Q.2d 1141, 1142 (Fed. Cir. 1987) (“Generic terms, by definition incapable of indicating source, are the antitheses of trademarks, and can never attain trademark status.”)).

²⁷² 782 F.2d 987, 228 U.S.P.Q. 528 (Fed. Cir. 1986).

²⁷³ *Katch*, 2019 U.S.P.Q.2d 233842 at *5, citing *Marvin Ginn*, 228 U.S.P.Q. at 530.

²⁷⁴ *Id.* See *Princeton Vanguard, LLC v. Frito-Lay N. Am., Inc.*, 786 F.3d 960, 114 U.S.P.Q.2d 1827, 1833 (Fed. Cir. 2015).

²⁷⁵ *Id.*, quoting *Royal Crown*, 127 U.S.P.Q.2d at 1046.

²⁷⁶ *Id.* at *6. See *In re Reed Elsevier Properties Inc.*, 482 F.3d 1376, 82 U.S.P.Q.2d 1378, 1380 (Fed. Cir. 2007); *Magic Wand*, 19 U.S.P.Q.2d at 1552 (a proper genericness inquiry focuses on the identification set forth in the application or registration).

namely, matching consumer requests for insurance policy quotes collected over the Internet to pre-qualified insurance brokers, agents, and agencies interested in those requests.”²⁷⁷ The record evidence confirmed that Applicant Katch’s services are in the health insurance field, and its website indicated that “health plans are an integral aspect of Applicant’s services.”²⁷⁸ Even though “health plans” were not expressly included in the recitation of services, they are still included in the relevant genus.²⁷⁹

As to the second prong of the *Marvin Ginn* test, the Board found that the relevant consumers are health insurance providers as well as members of the general public who are seeking health insurance from providers. The examining attorney submitted dictionary definitions of “health plan” and “health care,” excerpts from Applicant Katch’s own website, media references concerning the applicant, and LexisNexis articles and screenshots of third-party health insurance providers using the term “health plans.”

The record in this case clearly shows that “health plan(s)” is a common term that means an organized format for delivering health care insurance. It has been used generically on Applicant’s website . . . (e.g., “Find the Right Health Plan For You”), to indicate organized methods or formats for delivering health insurance.²⁸⁰

As to the suffix “.com,” only in exceptional circumstances will the addition of this TLD to a generic or descriptive term add source-identifying significance and transform an otherwise non-distinctive combination into a registrable mark.²⁸¹

The Board found that here, the TLD “.com” is “no more than a designation of commercial entity, like the word ‘Company,’ because it does not expand the meaning of ‘health plan(s)’ beyond an

²⁷⁷ *Id.*

²⁷⁸ *Id.* at *7.

²⁷⁹ *Id.* See *In re DNI Holdings Ltd.*, 77 U.S.P.Q.2d 1435 (T.T.A.B. 2005) (despite applicant’s omission of sports wagering from its recitation of services for the term SPORTSBETTING.COM, apparently to avoid a finding of genericness, “the relevant genus of services herein includes wagering on sporting events.” *Id.* at 1439). See also *Reed Elsevier*, 82 U.S.P.Q.2d at 1380 (affirming the Board’s finding that applicant’s provision of information regarding the law, legal news, and legal services included the provision of information about lawyers despite the deletion of those services from applicant’s recitation.).

²⁸⁰ *Id.* at *16-17.

²⁸¹ *Id.*, citing *In re Hotels.com LP*, 573 F.3d 1300, 91 U.S.P.Q.2d 1532, 1535 (Fed. Cir. 2009) (noting that “registrability does not depend on the .com combination”); *Steelbuilding.com*, 75 U.S.P.Q.2d at 1422 (“Only in rare instances will the addition of a TLD indicator to a descriptive term operate to create a distinctive mark.”) (citing *In re Oppedahl & Larson LLP*, 373 F.3d 1171, 71 U.S.P.Q.2d 1370, 1374 (Fed. Cir. 2004) (“When examining domain name marks, the PTO must evaluate the commercial impression of the mark as a whole, including the TLD indicator. The addition of a TLD such as ‘.com’ or ‘.org’ to an otherwise unregistrable mark will typically not add any source-identifying significance, similar to the analysis of ‘Corp.’ and ‘Inc.’”)).

organized format for delivering health insurance. A corporate identifier is without source-identifying capability.”²⁸²

Based upon the record evidence, the Board found that “relevant consumers would understand HEALTHPLANS.COM as denoting a commercial website for finding and being matched with available health plans, and thus as referring to the genus of Applicant’s Class 35 services.”²⁸³ Therefore, it concluded that the applied-for mark is generic for the Class 35 services “or at least a key aspect of them, namely, providing access to health insurance plans—or health plans—over the Internet.”²⁸⁴ Because the term is generic for at least some of the services in Class 35, it is unregistrable as to the entire class.²⁸⁵

Class 42: Turning to the Class 42 services, the relevant purchasers are insurers. Advertising is the focus of these services, and they “appear to be ancillary to, rather than an integral part of, providing health insurance.”²⁸⁶

Viewed in its entirety, the evidence of record indicates that HEALTHPLANS.COM in the context of these services merely describes a feature or characteristic of the services, but falls short of clearly demonstrating that insurers seeking to track, administer, bill, and report advertising over the Internet in the field of health insurance will understand HEALTHPLANS.COM to refer to the genus of Applicant’s Class 42 services.²⁸⁷

9. Color Mark

In re Forney Industries, Inc.

In a case of first impression, the Board ruled that a color mark consisting of multiple colors applied to product packaging cannot be inherently distinctive. Applicant Forney Industries did not seek registration under Section 2(f) in the alternative, and so the Board affirmed a refusal to register the mark shown below, comprising the colors “red into yellow with a black banner located near the top as

²⁸² *Id.* at *18-19. *See, e.g.,* Goodyear’s India Rubber Glove Mfg. Co. v. Goodyear Rubber Co., 128 U.S. 598, 602 (1888); *In re Wm. B. Coleman Co.*, 93 U.S.P.Q.2d 2019, 2025 (T.T.A.B. 2010); *In re Cell Therapeutics Inc.*, 67 U.S.P.Q.2d 1795 (T.T.A.B. 2003).

²⁸³ *Id.* at *20.

²⁸⁴ *Id.* *See Cordua Rests.*, 118 U.S.P.Q.2d at 1638 (explaining that “the term ‘pizzeria’ would be generic for restaurant services, even though the public understands the term to refer to a particular sub-group or type of restaurant rather than to all restaurants”).

²⁸⁵ *Id.* at *21. *See In re Analog Devices Inc.*, 6 U.S.P.Q.2d 1808, 1810 (T.T.A.B. 1988), *aff’d*, 871 F.2d 1097, 10 U.S.P.Q.2d 1879 (Fed. Cir. 1989) (unpublished).

²⁸⁶ *Id.*

²⁸⁷ *Id.*

applied to packaging” for the applicant’s metal hardware, welding equipment, safety goods, and marking products.²⁸⁸



Nature of the Mark: Applicant Forney maintained that its purported mark is not a “color mark” but rather should be treated as product packaging and therefore capable of being inherently distinctive.²⁸⁹ However, the Board, based on the application drawing, agreed with the examining attorney that the mark is a color mark, consisting of multiple colors applied to product packaging.

Here, the drawing shows Applicant’s mark surrounded by dotted or broken lines, indicating the mark’s placement on product packaging. The mark description confirms this understanding. It states that the dotted lines are used to “merely depict placement of the mark” on the packing backer card. 37 C.F.R. §2.52(b)(4) (requiring mark description to explain the purpose of the broken lines); *see also* TMEP § 807.08. The particular shape of the product packaging (which varies as revealed by the specimens) is not claimed as part of the mark. The only elements claimed by Applicant, as amended, in the applied-for mark are the colors as applied to “the packer backing card.”²⁹⁰

On Forney’s specimens of use the mark appears in “widely-differing shapes”²⁹¹ rather than in any particular shape, and so the Board concluded that the mark should be treated as a color mark consisting of multiple colors applied to product packaging.

Registrability of the Mark: The examining attorney maintained that color marks are never inherently distinctive, citing *Qualitex*

²⁸⁸ *In re Forney Indus., Inc.*, 127 U.S.P.Q.2d 1787 (T.T.A.B. 2018).

²⁸⁹ The Supreme Court in *Two Pesos, Inc. v. Taco Cabana, Inc.*, 505 U.S. 763, 23 U.S.P.Q.2d 1081, 1085-86 (1992) held that trade dress (and particularly, restaurant décor) may be inherently distinctive, and in *Wal-Mart Stores, Inc. v. Samara Bros, Inc.*, 529 U.S. 205, 54 U.S.P.Q.2d 1065, 1069-70 (2000), the Court acknowledged that product packaging trade dress may be inherently distinctive.

²⁹⁰ *Forney Indus.*, 127 U.S.P.Q.2d at 1790.

²⁹¹ *Id.*

(green press pad)²⁹² and *Owens-Corning* (pink insulation).²⁹³ The Board observed, however, that those two cases are distinguishable because they involved a single color and the single color was applied to a product.

Here, by contrast, the issues presented are: (A) whether there is a different rule for inherent distinctiveness for color marks applied to product packaging than for color applied to a product itself; and (B) whether the rule that single-color marks cannot be inherently distinctive applies to color marks consisting of more than one color.²⁹⁴

In *Wal-Mart* and *Qualitex*, the Supreme Court made clear that “a particular color on a product or its packaging” can never be inherently distinctive.²⁹⁵ Recently in *In re Gen. Mills IP Holdings II, LLC*, the Board followed suit, holding that although a “color applied to a product or *its packaging* may function as a trademark . . . color can never be inherently distinctive as a source indicator.”²⁹⁶

The Board saw no legal distinction between a single color mark and one consisting of multiple colors “without additional elements, e.g., shapes or designs.”²⁹⁷ It concurred with the analysis of the U.S. Court of Appeals for the Tenth Circuit in *Forney Industries, Inc. v. Daco of Missouri, Inc.*²⁹⁸ that, because there was no consistent shape, pattern, or design to the purported mark there at issue (which was similar to the applied-for mark here), Forney failed to establish an inherently distinctive trade dress.

We agree with the Tenth Circuit’s analysis of the relevant case law, and hold that a color mark consisting of colors applied to product packaging cannot be inherently distinctive, and may be registered on the Principal Register only upon adequate proof of acquired distinctiveness. Under that legal standard, we find that Applicant’s color mark which is not combined with a distinctive well-defined shape, pattern or other distinctive design is not inherently distinctive.²⁹⁹

The Board observed that, even if colors could be inherently distinctive, nothing in the record indicated that Applicant Forney’s multiple color mark would be so perceived. Because Forney did not

²⁹² 514 U.S. 159, 34 U.S.P.Q.2d 1161, 1162-63 (1995).

²⁹³ 774 F.2d 1116, 227 U.S.P.Q. 417, 419 (Fed. Cir. 1985).

²⁹⁴ *Forney Indus.*, 127 U.S.P.Q.2d at 1791.

²⁹⁵ See *Wal-Mart*, 54 U.S.P.Q.2d at 1068 and *Qualitex*, 34 U.S.P.Q.2d at 1162-63.

²⁹⁶ 124 U.S.P.Q.2d 1016, 1018 (T.T.A.B. 2017) (emphasis added).

²⁹⁷ *Forney Indus.*, 127 U.S.P.Q.2d at 1792.

²⁹⁸ 835 F.3d 1238, 120 U.S.P.Q.2d 1035, 1039 (10th Cir. 2016).

²⁹⁹ *Forney Indus.*, 127 U.S.P.Q.2d at 1793.

request registration under § 2(f) in the alternative, acquired distinctiveness was not at issue.

And so, the Board affirmed the refusal to register under Sections 1, 2, and 45 of the Lanham Act.

PART II. INTER PARTES CASES

A. United States Court of Appeals for the Federal Circuit

1. Section 2(d) Likelihood of Confusion

Cai v. Diamond Hong, Inc.

Despite Appellant Cai’s procedural complaints, the CAFC affirmed the TTAB’s decision ordering cancellation of a registration for the mark WU DANG TAI CHI GREEN TEA & Design (shown below left) for “green tea; tea; tea bags,” in view of the registered mark TAI CHI & Design (shown below right) for, inter alia, tea. The CAFC ruled that the Board had properly refused to consider evidence contained in the respondent’s main brief and also properly rejected the respondent’s reply brief. The court then concluded that substantial evidence supported the Board’s finding of likelihood of confusion.³⁰⁰



Evidentiary Rulings: The TTAB considered the arguments presented in Mr. Cai’s Main Brief but not “the factual assertions and ‘figures’ displayed and discussed in [Mr. Cai’s] brief, which are not evidence introduced into the trial record.”³⁰¹ The Board also refused to consider Mr. Cai’s reply brief because the Trademark Board Manual of Procedure (“TBMP”) does not provide for, and gives the TTAB broad discretion when deciding whether to consider, such a filing.³⁰²

Although the procedural guidelines in the TBMP do not have the force of law, *see* TBMP Introduction (explaining that “[t]he manual does not modify, amend, or serve as a substitute for any existing statutes, rules, or decisional law and is not binding upon the [TTAB or] its reviewing

³⁰⁰ *Cai v. Diamond Hong, Inc.*, 901 F.3d 1367, 127 U.S.P.Q.2d 1797 (Fed. Cir. 2018).

³⁰¹ *Id.* at 1799.

³⁰² *Id.* at 1799. In *Christensen v. Harris County*, the Supreme Court stated that agency manuals “lack the force of law” but are still “entitled to respect.” (529 U.S. 576, 587 (2000)).

tribunals”), the TBMP is accorded a degree of deference to the extent that it has the “power to persuade.”³⁰³

The CAFC has previously affirmed TTAB determinations with regard to the admission of evidence when they are clearly in line with the language of the TBMP.³⁰⁴ Mr. Cai’s Main Brief at the TTAB contained numerous assertions of fact; such assertions are “not evidence under any of the relevant rules.”³⁰⁵ And so, the court concluded that the TTAB did not abuse its discretion in ruling that Mr. Cai submitted no evidence in the Board proceeding.³⁰⁶

As to his reply brief, the TBMP plainly states that the TTAB is not required to permit “a party in the position of defendant” to file a reply.³⁰⁷ Mr. Cai was the defendant in the cancellation proceeding. The Court concluded that the Board did not abuse its discretion in refusing to consider his reply.

Likelihood of Confusion: The CAFC reviews the TTAB’s factual findings on each *du Pont* factor for substantial evidence and its legal conclusion of likelihood of confusion de novo.³⁰⁸ The court concluded that the Board did not err.

The Board had considered the first three *du Pont* factors, since there was no evidence submitted under the other factors. Substantial evidence supported the Board’s findings.³⁰⁹ The goods are identical in part and the Board correctly presumed that these identical goods move in the same trade channels and are available to the same classes of customers: members of the general public who purchase or consume tea.³¹⁰

³⁰³ *Id.*, citing *Christensen*, 529 U.S. at 587.

³⁰⁴ *Id. See, e.g.*, *Bishop v. Flournoy*, 319 F. App’x 897, 899-900 (Fed. Cir. 2009) (agreeing with the TTAB’s position, based on TBMP guidelines, that it was not required to consider certain evidence); *In re DSS Envtl., Inc.*, 113 F. App’x 902, 907 (Fed. Cir. 2004) (similar); *see also* *Am. Rice, Inc. v. Dunmore Props. S.A.*, 353 F. App’x 428, 432 (Fed. Cir. 2009) (affirming a TTAB determination based on the TBMP concerning denial of a motion for an extension of time to conduct discovery).

³⁰⁵ *Id.*

³⁰⁶ The CAFC reviews evidentiary rulings for abuse of discretion. *Coach Servs., Inc. v. Triumph Learning LLC*, 668 F.3d 1356, 101 U.S.P.Q.2d 1713, 1717 (Fed. Cir. 2012).

³⁰⁷ *Cai*, 127 U.S.P.Q.2d at 1799. *See* TBMP § 801.02(d); *Odom’s Tenn. Pride Sausage, Inc. v. FF Acquisition, L.L.C.*, 600 F.3d 1343, 93 U.S.P.Q.2d 2030, 2032 (Fed. Cir. 2010) (“[the CAFC] give[s] the TTAB significant latitude in applying the TBMP when the language therein is ‘permissive’”).

³⁰⁸ *Id.* at 1800, citing *Stone Lion Capital Partners, L.P. v. Lion Capital LLP*, 746 F.3d 1371, 101 U.S.P.Q.2d 1157, 1160 (Fed. Cir. 2014).

³⁰⁹ *Id.*

³¹⁰ *Id.* at 1801, citing *Viterra*, 101 U.S.P.Q.2d at 1908 (“[I]t is well established that, absent restrictions in the application and registration, [identical] goods and services are presumed to travel in the same channels of trade to the same class of purchasers.” (internal quotation marks and citation omitted)).

As to the marks, when the goods are identical, a lesser degree of similarity is necessary to support a conclusion of likely confusion.³¹¹ When considered in their entireties, the marks at issue are similar because both “invoke a large yin-yang symbol and prominently display the term TAI CHI.”³¹² “The fact that color is not claimed as a feature of Diamond Hong’s mark . . . further highlights the likelihood of confusion because, as the TTAB correctly identified, Diamond Hong’s mark ‘could be presented in a green-and-white color scheme like [Mr. Cai’s] mark.’”³¹³

Concluding that “the TTAB’s findings as to the *DuPont* factors are supported by substantial evidence and the TTAB did not err in finding a likelihood of confusion,”³¹⁴ the CAFC affirmed.

Omaha Steaks International v. Greater Omaha Packing Co.

The CAFC vacated the TTAB’s decision³¹⁵ finding the mark GREATER OMAHA PROVIDING THE HIGHEST QUALITY BEEF & Design (shown below) for “meat, including boxed beef primal cuts” not likely to cause confusion with the registered mark OMAHA STEAKS for meat. The appellate court ruled that the Board’s analysis regarding the fame of the OMAHA STEAKS mark was “legally flawed,” and the Board’s consideration of third-party uses “improperly relied on marks found on dissimilar goods and services not directed to the relevant public.”³¹⁶



Omaha Steaks challenged the Board’s decision in three areas: first, it contended that the Board ignored evidence of the fame of the OMAHA STEAKS marks under the fifth *du Pont* factor; second, it argued that the Board relied on a much broader range of goods lacking any similarity to meat products when evaluating the *sixth* *du Pont* factor (which examines the number and nature of third-party uses of similar marks on “similar goods”); and third, Omaha

³¹¹ *Id.*, citing *Viterra*, 101 U.S.P.Q.2d at 1908. (“[W]here . . . the goods at issue are identical, the degree of similarity necessary to support a conclusion of likely confusion declines.” (internal quotation marks and citation omitted)).

³¹² *Id.*

³¹³ *Id.*

³¹⁴ *Id.*

³¹⁵ *Omaha Steaks Int’l v. Greater Omaha Packing Co.*, Consolidated Opposition No. 91213527 and Cancellation Nos. 92059629 and 92059455 (T.T.A.B. Sept. 30, 2017).

³¹⁶ *Omaha Steaks Int’l v. Greater Omaha Packing Co.*, 908 F.3d 1315, 128 U.S.P.Q.2d 1686 (Fed. Cir. 2018).

Steaks maintained that the Board's analysis of the similarity between the marks was improper because the Board ignored the word "BEEF" in Greater Omaha's slogan "Providing the Highest Quality Beef."³¹⁷

Fame: As to the evidence of fame (i.e., commercial strength) under the fifth *du Pont* factor, the court agreed with Omaha Steaks that the TTAB's discounting of its evidence of fame was "legally flawed."³¹⁸ The Board had concluded that Omaha Steaks' "raw" figures regarding sales and advertising expenditures lacked context and it therefore disregarded them.³¹⁹ The Board interpreted *Bose Corp. v. QSC Audio Products, Inc.*,³²⁰ as requiring evidence of "market share," not just sales and advertising figures. Not so, said the CAFC: "Though *Bose* expressly approves of using market share, it does not require it."³²¹

Omaha Steaks provided considerable contextual evidence of the type of advertisements and promotions it uses to gain sales, including testimony as to how it promoted its products through catalogs, direct mailings, e-mail marketing, customer calls, tradeshow, retail stores, national television, radio, magazine and newspaper campaigns, digital marketing, and social media. The CAFC concluded that the Board's finding of lack of context for Omaha Steaks' "raw" sales and advertising figures lacked substantial evidence.³²²

In light of our holding in *Bose*, the Board took an overly restrictive view of evidence related to Omaha Steaks' sales figures, advertising expenditures, and related evidence of the relevant public's exposure to its branded meat products bearing on the relative fame of the mark. Accordingly, we vacate and remand to allow the Board to conduct a proper analysis of this factor.³²³

The CAFC ruled that the Board did not err in finding that Omaha Steaks' survey evidence was flawed and lacked probative value because the universe surveyed was too narrow.³²⁴ Nor did the Board err in refusing to take judicial notice of the contents of the complaints filed in various litigations identified by Omaha Steaks. "The Board is not required to scour, not just the dockets, but the

³¹⁷ *Id.* at 1689.

³¹⁸ *Id.* at 1692.

³¹⁹ *Id.* at 1690. The CAFC noted that the company spent more than \$45 million in 2011 and more than \$50 million in 2012 and 2013 on domestic advertising of its beef products. During the December holiday season Omaha Steaks processes 100,000 orders per day.

³²⁰ 293 F.3d 1367, 63 U.S.P.Q.2d 1303, 1309 (Fed. Cir. 2002).

³²¹ *Omaha Steaks Int'l*, 128 U.S.P.Q.2d at 1690.

³²² *Id.* at 1691.

³²³ *Id.* at 1692.

³²⁴ *Id.*

multiple pleadings referenced in those dockets to determine the substance of the litigations referenced.”³²⁵

Third-party uses: The sixth *du Pont* factor considers “[t]he number and nature of similar marks in use on similar goods.”³²⁶ Third-party use is “relevant to show that a mark is relatively weak and entitled to only a narrow scope of protection,” because consumers have become accustomed to distinguishing between different marks “on the bases of minute distinctions.”³²⁷

The Board found the involved goods to be legally identical, but it “considered a variety of services and products that include the word ‘Omaha,’ regardless of whether they involve meat.”³²⁸ Although finding that this evidence was “not overwhelming,” the Board deemed the evidence sufficient to support a finding that the term “OMAHA” “may be perceived as an indication of the geographic location of the producer of the goods or the geographic origin of the goods themselves.”³²⁹ The Board then determined that OMAHA is weak as a source indicator and that marks including the word “OMAHA” are entitled to only a narrow scope of protection.

The Board’s analysis was flawed. As we underscored in *Century 21*, the “relevant *du Pont* inquiry is [t]he number and nature of similar marks in use on similar goods.” *Century 21 Real Estate Corp. v. Century Life of Am.*, 970 F.2d 874, 877 (Fed. Cir. 1992) (quoting *Weiss Assocs., Inc. v. HRL Assocs., Inc.*, 902 F.2d 1546, 1548 (Fed. Cir. 1990)).³³⁰

The Board cited to a list of businesses with OMAHA in their names, offering diverse products like popcorn, wine, oriental food, and alcoholic beverages. The CAFC observed that “these goods bear no relationship to meat or meat-based products. Accordingly, such goods are not ‘similar’ to meat products.”³³¹

Greater Omaha argued that these third-party products are “similar” to meat because they are food products. The court was unmoved; it found no evidence that these other products are related to meat.

[Greater Omaha’s] mark on meat products cannot escape a likelihood of confusion with Omaha Steaks’ prior use on meat products in the relevant market for meat purely because other “Omaha” marks are being used by third parties on

³²⁵ *Id.* at 1693.

³²⁶ *Id.*, citing *du Pont*, 177 U.S.P.Q. at 567.

³²⁷ *Id.*, quoting *Palm Bay Imps., Inc. v. Veuve Clicquot Ponsardin Maison Fondée en 1772*, 396 F.3d 1369, 73 U.S.P.Q.2d 1689, 1693 (Fed. Cir. 2005).

³²⁸ *Id.*

³²⁹ *Id.*

³³⁰ *Id.* at 1693-94.

³³¹ *Id.* at 1694.

popcorn, alcoholic beverages, or other food products. Independent of these third-party uses on other goods, there may still be confusion between Omaha Steaks' marks and [Greater Omaha's] new mark for consumers purchasing meat.³³²

Because the Board's analysis under the sixth *du Pont* factor was "fatally flawed," the court vacated its finding and remanded the case with instructions to the Board to "reweigh the limited, relevant evidence of third-party use."³³³

Where's the BEEF? Omaha Steaks' third argument rested on a single sentence in the Board opinion: "Defendant's mark is dominated by the words GREATER OMAHA; they are the first words in the mark, are visually larger than the laudatory slogan, 'PROVIDING THE HIGHEST QUALITY,' and are the words that would be used to call for the goods."³³⁴ The CAFC observed that the Board's omission of the word "BEEF" in Greater Omaha's slogan appeared to be a typographical error, and it noted that on seven other occasions the Board correctly referred to the entire slogan.³³⁵

The CAFC concluded that the Board had "adequately assessed the slogan" and, in fact, had found the slogan to be one of the differences in the overall appearances of the involved marks.³³⁶ However, because the Board's findings regarding the strength of the term "OMAHA" were vacated, the Board must reconsider its finding under the first *du Pont* factor.

2. Section 2(e)(1) Mere Descriptiveness/Genericness

Real Foods Pty., Ltd. v. Frito-Lay North America, Inc.

The CAFC issued a split decision in this appeal from the TTAB's ruling³³⁷ sustaining Frito-Lay's oppositions to registration of CORN THINS for "crispbread slices predominantly of corn, namely popped corn cakes," and RICE THINS for "crispbread slices primarily made of rice, namely rice cakes" [CORN and RICE disclaimed]. The appellate court upheld the Board's findings that the marks are merely descriptive of the goods and lack acquired distinctiveness. However, it vacated the Board's holding that the marks are not

³³² *Id.* at 1695.

³³³ *Id.* The "remaining relevant evidence largely consists of third-party meat products from meat processing or packaging companies, such as B.I.G. Meats Omaha, Omaha Beef Company, and Omaha Meat Processors." *Id.*

³³⁴ *Id.*

³³⁵ *Id.*

³³⁶ *Id.* at 1696.

³³⁷ *Frito-Lay N. Am., Inc., v. Real Foods Pty., Ltd., Opposition Nos. 91212680 and 91213587* (T.T.A.B. 2017).

generic for the goods, remanding the case for reconsideration of the genus selected by the Board for its analysis.³³⁸

Mere Descriptiveness: Substantial evidence supported the Board's finding that the marks are "highly descriptive" of the goods.³³⁹ The terms "corn" and "rice" are descriptive because "they identify 'ingredients,' which are 'qualities or properties' of Real Foods' goods."³⁴⁰ The term "thins" describes physical characteristics of the goods, and the composite terms do not create a commercial impression different from the individual components. They immediately convey information of a quality or characteristic of the products.³⁴¹

Appellant Real Foods urged that the marks are double entendres, but the CAFC agreed with the Board that the marks have no additional suggestive meaning, since the word "thins" has been used with food products that are thin in shape. The existence of several third-party registrations for marks containing the word "thins" was of limited probative value because, as the Board has repeatedly pointed out, each trademark application must be examined on its own merits.³⁴²

Acquired Distinctiveness: Substantial evidence supported the Board's finding that Real Foods had failed to prove that the applied-for marks have acquired distinctiveness. According to the Board, Real Foods "has done little or no advertising," and its sales figures "while not insignificant, are not high."³⁴³ Moreover, the use of the term "thins" is not limited to the applicant. Opposer Frito Lay's survey showed less than 10% recognition of the mark as a source indicator, establishing, according to the Board, the "limited recognition of CORN THINS as a mark."³⁴⁴

Similar survey data has been held to demonstrate that a descriptive mark has not acquired distinctiveness. For example, in *Roselux Chemical Co. v. Parsons Ammonia Co.*, our predecessor court reversed a trademark registration [sic], finding the mark descriptive and not having acquired distinctiveness, where the survey data demonstrated that only "10% of the people who actually know the [ammonia]

³³⁸ Real Foods Pty., Ltd. v. Frito-Lay N. Am., Inc., 906 F.3d 965, 128 U.S.P.Q.2d 1370 (Fed. Cir 2018).

³³⁹ *Id.* at 1374.

³⁴⁰ *Id.* at 1375, quoting *In re Gyulay*, 820 F.2d 1216, 3 U.S.P.Q.2d 1009, 1010 (Fed. Cir. 1987) (internal quotation marks and citation omitted).

³⁴¹ *Id.*

³⁴² *Id.* at 1377. See *Cordua Rests.*, 118 U.S.P.Q.2d at 1635 ("The [US]PTO is required to examine all trademark applications for compliance with each and every eligibility requirement . . . even if the [US]PTO earlier mistakenly registered a similar or identical mark suffering the same defect.").

³⁴³ *Id.*

³⁴⁴ *Id.*

product” called it by the name of the proposed mark. 299 F.2d 855, 862, 49 C.C.P.A. 931, 1962 Dec. Comm’r Pat. 174 (C.C.P.A. 1962).³⁴⁵

Genericness: The Board identified the genus of the goods as “popped corn cakes” for CORN THINS and “rice cakes” for RICE THINS. The CAFC pointed out, however, that “[A] term can be generic for a genus of goods or services if the relevant public understands the term to refer to a *key aspect* of that genus.”³⁴⁶ Furthermore, the question of registrability must be decided on the basis of the identification of the goods set forth in the application, regardless of the actual nature of the applicant’s goods.³⁴⁷

The TTAB improperly narrowed the genus of the goods at issue. The Applications initially identified the goods as “[c]rispbread slices predominantly of corn,” . . . and “crispbread slices primarily made of rice,” . . . During the opposition proceedings, Real Foods moved to amend the goods as “crispbread slices predominantly of corn, *namely popped corn cakes*” and “crispbread slices primarily made of rice, *namely rice cakes*” . . . (emphases added), and the TTAB granted Real Foods’ motion to amend. . . . In its Opinion, the TTAB defined the genus of the goods strictly by reference to the *newly added* portion of the amended language, identifying the genus as “popped corn cakes” for the CORN THINS mark and “rice cakes” for the RICE THINS mark.³⁴⁸

The Board failed to consider that the application’s popped corn cakes and rice cakes are types of crispbread slices, “which, in turn, the record defines as types of crackers.”³⁴⁹ This was error. “[C]orn cakes and rice cakes are the species, not the genus.”³⁵⁰ The Board provided no reasoning for choosing the narrowed identification of goods as the genus.

The CAFC therefore remanded the case to the Board “to reconsider its selected genus and conduct its genericness analysis in light of that genus.”³⁵¹

³⁴⁵ *Id.* at 1378.

³⁴⁶ *Id.* at 1379, quoting *Royal Crown*, 127 U.S.P.Q.2d at 1046.

³⁴⁷ *Cordua Rest.*, 118 U.S.P.Q.2d at 1636. See *Octocom Sys., Inc. v. Hous. Comput. Servs., Inc.*, 918 F.2d 937, 16 U.S.P.Q.2d 1783, 1787 (Fed. Cir. 1990):

The authority is legion that the question of registrability of an applicant’s mark must be decided on the basis of the identification of goods set forth in the application regardless of what the record may reveal as to the particular nature of an applicant’s goods, the particular channels of trade or the class of purchasers to which sales of the goods are directed.

³⁴⁸ *Id.* at 1379.

³⁴⁹ *Id.* at 1380.

³⁵⁰ *Id.*

³⁵¹ *Id.* On remand, the Board found, in a non-precedential ruling, that the terms “CORN THINS” and “RICE THINS” “refer to a subcategory of crackers” and are generic. *Frito-*

3. Section 2(f) Acquired Distinctiveness

Schlafly v. The Saint Louis Brewery, LLC

In this rather quixotic appeal, the CAFC upheld the TTAB's decision³⁵² dismissing two oppositions to registration of the mark SCHLAFLY for beer. The opposers, Dr. Bruce S. Schlafly and Phyllis Schlafly,³⁵³ claimed that SCHLAFLY is primarily merely a surname and therefore barred from registration by Section 2(e)(4),³⁵⁴ but the Board did not rule on the surname issue, instead finding that Applicant St. Louis Brewery ("SLB") had established acquired distinctiveness in the mark.³⁵⁵

The opposers/appellants contended that the TTAB failed to recognize that the mark SCHLAFLY is primarily merely a surname and improperly accepted SLB's proof of acquired distinctiveness despite a lack of survey evidence. The appellants also claimed that their constitutional rights under the First³⁵⁶ and Fifth³⁵⁷ Amendments were violated. The CAFC disagreed on all points.

Acquired Distinctiveness: Trademark Rule 2.41 provides that the following types of evidence may be considered to show acquired distinctiveness: (1) ownership of prior registration(s); (2) five years substantially exclusive and continuous use in commerce; and (3) other evidence (such as proof of duration, extent, and nature of use, advertising expenditures, verified statements from the trade and/or public, etc.).³⁵⁸ SLB submitted all three types of evidence

Lay N. Am., Inc. v. Real Foods Pty. Ltd., Opposition Nos. 91212680 and 91213587 (T.T.A.B. Sept. 24, 2019).

³⁵² Schlafly v. St. Louis Brewery, LLC, Oppositions Nos. 91207224 and 91207225 (T.T.A.B. Aug. 2, 2016).

³⁵³ Thomas Schlafly co-founded the St. Louis Brewery in 1989 and began selling SCHLAFLY beer in 1991. His aunt, Phyllis Schlafly, and her son, Dr. Bruce Schlafly, each filed an opposition based on the same grounds, and the Board consolidated the oppositions *sua sponte*. Andrew Schlafly (another son of Phyllis) served as the attorney for the opposers in the oppositions and in this appeal.

³⁵⁴ Section 2(e)(4) of the Lanham Act, 15 U.S.C. § 1052(e)(4), bars registration of a mark that "is primarily merely a surname."

³⁵⁵ Schlafly v. Saint Louis Brewery, LLC, 909 F.3d 420, 128 U.S.P.Q.2d 1739 (Fed. Cir. 2018).

³⁵⁶ The First Amendment to the United States Constitution states, in pertinent part: "Congress shall make no law . . . abridging the freedom of speech, or of the press . . ." U.S. Const. amend. 1.

³⁵⁷ The Fifth Amendment provides, in pertinent part, that "No person shall be . . . deprived of life, liberty, or property, without due process of law; nor shall private property be taken for public use, without just compensation." U.S. Const. amend. 5.

³⁵⁸ Trademark Rule 2.41(a), 37 C.F.R. § 2.41(a) (2015), states:

For a trademark or service mark—(1) Ownership of prior registration(s). In appropriate cases, ownership of one or more active prior registrations on the Principal Register or under the Trademark Act of 1905 of the same mark may be accepted as prima facie evidence of distinctiveness if the goods or services are sufficiently similar to the goods or services in the application; however, further

and, in all, the Board considered fifteen different forms of evidence in reaching its conclusion, including proof of commercial success of SCHLAFLY branded beer, media coverage, continuous use of the mark for more than twenty-five years, and direct evidence in the form of press notices. The CAFC observed that “[t]he Board and courts have recognized that both direct and circumstantial evidence may show secondary meaning.”³⁵⁹

The appellants argued that the public primarily perceives SCHLAFLY as the surname of Phyllis Schlafly, a well-known activist (now deceased). They urged the CAFC to adopt a new test called the “change in significance” test, whereby a surname cannot be registered without showing a change in significance from a surname to a mark.³⁶⁰ However, the appellants provided no legal support for this contention.

The appellants also argued that the Board refused to determine whether SCHLAFLY is primarily merely a surname, even though Section 2(e)(4) prohibits registration of such a surname. The Board, however, was correct in stating that Section 2(f) of the Lanham Act provides for registration of words that are primarily merely a surname but have acquired “secondary meaning” (i.e., acquired distinctiveness).³⁶¹ “No law or precedent suggests that surnames

evidence may be required. (2) Five years substantially exclusive and continuous use in commerce. In appropriate cases, if a trademark or service mark is said to have become distinctive of the applicant's goods or services by reason of the applicant's substantially exclusive and continuous use of the mark in commerce for the five years before the date on which the claim of distinctiveness is made, a showing by way of verified statements in the application may be accepted as prima facie evidence of distinctiveness; however, further evidence may be required. (3) Other evidence. In appropriate cases, where the applicant claims that a mark has become distinctive in commerce of the applicant's goods or services, the applicant may, in support of registrability, submit with the application, or in response to a request for evidence or to a refusal to register, verified statements, depositions, or other appropriate evidence showing duration, extent, and nature of the use in commerce and advertising expenditures in connection therewith (identifying types of media and attaching typical advertisements), and verified statements, letters or statements from the trade or public, or both, or other appropriate evidence of distinctiveness.

³⁵⁹ *Schlafly*, 128 U.S.P.Q.2d at 1743, citing *Yamaha Int'l Corp. v. Hoshino Gakki Co., Ltd.*, 840 F.2d 1572, 6 U.S.P.Q.2d 1001, 1010 (Fed. Cir. 1988) (“[A]bsence of consumer surveys need not preclude a finding of acquired distinctiveness. . . . To prove distinctiveness under 15 U.S.C. § 1052(f), applicants may submit any appropriate evidence tending to show that the mark distinguishes [applicant's] goods.”) (internal quotation marks omitted).

³⁶⁰ *Id.*

³⁶¹ *Id.* Section 2(f) of the Lanham Act, 15 U.S.C. § 1052(f), provides in pertinent part:

Except as expressly excluded in subsections (a), (b), (c), (d), (e)(3), and (e)(5) of this section, nothing herein shall prevent the registration of a mark used by the applicant which has become distinctive of the applicant's goods in commerce. The Director may accept as prima facie evidence that the mark has become distinctive, as used on or in connection with the applicant's goods in commerce, proof of substantially exclusive and continuous use thereof as a mark by the

cannot be registered as trademarks if they have acquired distinctiveness in trademark use. Because the Board found that the SCHLAFLY mark for beers had acquired secondary meaning, Section 1052(e)(4) did not bar the registration.”³⁶²

Constitutional Claims: The Board gave short shrift to the appellants’ constitutional claims because they failed to explain “how registration improperly impinges on their First Amendment rights.”³⁶³ The Fifth Amendment claim of improper taking of property failed because “trademark registration is not a taking for government use.”³⁶⁴

The appellants also asserted that their Due Process rights under the Fifth Amendment were violated when the Board recognized secondary meaning in the SCHLAFLY mark without proof of a change in public perception of the mark. The CAFC ruled, however, that the trademark opposition procedure “provides appropriate process of law.”³⁶⁵

B. Trademark Trial and Appeal Board

1. Section 2(c) Consent to Register

*M/S R.M. Dhariwal (HUF) 100% EOU v.
Zarda King Ltd. et al.*

In a rare inter partes proceeding involving Section 2(c), the Board dismissed an opposition to registration of the mark MANIKCHAND for “snuff.” The opposer maintained that the mark identified its founder, Rasiklal Manikchand Dhariwal, and that the application was filed without his consent. However, Mr. Dhariwal died during the pendency of this proceeding, and the Board ruled that the opposer no longer could claim any right under Section 2(c).³⁶⁶

15 U.S.C. § 1052(c) (“Section 2(c)”) prohibits registration of a mark that consists of or comprises a name, portrait, or signature identifying a particular living individual except with his or her written consent. This provision applies not only to full names but

applicant in commerce for the five years before the date on which the claim of distinctiveness is made.

³⁶² *Id.* at 1743-44.

³⁶³ *Id.* at 1744.

³⁶⁴ *Id.*

³⁶⁵ *Id.*

³⁶⁶ *M/S R.M. Dhariwal (HUF) 100% EOU v. Zarda King Ltd. et al.*, 2019 U.S.P.Q.2d 149090 (T.T.A.B. 2019). The Board also faced an evidentiary issue regarding the opposer’s testimony declaration, discussed in Part II.B.10.d, below.

also to shortened names and nicknames, as long as the name identifies a particular living individual.³⁶⁷

Each of the opposer's tobacco products bears the statement: "Formulation by Rasiklal Manikchand Dhariwal." The Board therefore found that the opposer was in privity with its founder for purposes of bringing an opposition under Section 2(c).³⁶⁸

When the opposition was filed Mr. Dhariwal was alive, but he died during the pre-trial phase of the proceeding. The opposer argued that his death had no effect on the Section 2(c) issue, but the Board disagreed. "Because a § 2(c) claim is based on public association with the name of a particular living individual, the question of present-day recognition by the public must be considered at the time registration is sought, since an individual's notoriety with the public could fade over time."³⁶⁹

The Board concluded that any right that the opposer may have had under § 2(c) expired upon Mr. Dhariwal's death because he was the "particular living individual" protected by § 2(c).

Whatever the facts were at the time the subject application was filed or when this proceeding commenced, evidence adduced at trial establishes that Mr. Dhairwal [sic] had by then passed away, extinguishing any right to oppose on the ground that the mark in the subject application is the name of a *living* individual. To the extent that Opposer has rights regarding the use or registration of the MANIKCHAND name after Mr. Dhariwal's death, they do not arise under § 2(c).³⁷⁰

2. Section 2(e)(1) Mere Descriptiveness

Robinson v. Hot Grabba Leaf, LLC

Petitioner Michael A. Robinson saw his petition for cancellation go up in smoke when the Board granted the respondent's counterclaim for cancellation of Robinson's pleaded registrations for the mark GRABBA LEAF, in standard character and design form

³⁶⁷ *Id.* at *13, citing *In re Sauer*, 27 U.S.P.Q.2d 1073, 1074-75 (T.T.A.B. 1993), *aff'd*, 26 F.3d 140 (Fed. Cir. 1994).

³⁶⁸ *Id.* at *12. *Cf.* *John W. Carson Foundation v. Toilets.com Inc.*, 94 U.S.P.Q.2d 1942, 1947 (T.T.A.B. 2010) (for purposes of preclusion, privity found between decedent and his foundation (plaintiff); privity also found between sole owner and president and his company (defendant)) (citing *Vitronics Corp. v. Conception, Inc.*, 27 U.S.P.Q.2d 1046, 1049 (D.N.H. 1992) (founder and CEO of corporation in privity with corporation)).

³⁶⁹ *Id.* at *15-16.

³⁷⁰ *Id.* at *17-18. In its main brief, the opposer argued the ground of false association under Section 2(a), a claim that presumably would have survived the death of Mr. Dhariwal. However, this ground had not been pleaded and applicant objected to its consideration. The Board concluded that the Section 2(a) issue was not tried by consent and it therefore refused to consider it. *Id.* at *9.

(shown below), for cigar wraps. Robinson alleged that the respondent's mark, HOT GRABBA NATURAL TOBACCO LEAF for leaf tobacco, would likely cause confusion with his registered marks. The Board, however, found Robinson's marks to be merely descriptive, and so it granted the counterclaim and dismissed his petition for cancellation.³⁷¹



In response to the counterclaim, Robinson argued only that his marks are inherently distinctive and he did not claim acquired distinctiveness. He had disclaimed any rights in the word “LEAF,” and the Board took that disclaimer as an admission that “LEAF” is merely descriptive of cigar wraps.³⁷²

Third-party website evidence submitted by the respondent showed the terms “grabba” and “grabba leaf” used in connection with tobacco products, including cigar wraps. A definition of “grabba” from the Urban Dictionary was also probative: “A Jamaican term used to describe something mixed with marijuana when smoked so as to keep the sent [sic] down and to get rid of the bad aftertaste.”³⁷³

Moreover, statements made by Robinson in the declaration from his application files were also pertinent, since they contradicted his claim of non-descriptiveness:

Paragraph 6: Since my use of the GRABBA LEAF trademarks, the term GRABBA has entered pop culture vernacular, through amongst other things, the use in songs in the Caribbean, namely Vybz Kartel featuring Popcaan—Hot Grabba, released June 2010.

³⁷¹ Robinson v. Hot Grabba Leaf, LLC, 2019 U.S.P.Q.2d 149089 (T.T.A.B. 2019). The respondent's motion to strike Robinson's testimony declaration (because it was not signed during his testimony period) is discussed in Part II.B.10.c, below.

³⁷² *Id.* at *14.

³⁷³ *Id.* at *17.

Paragraph 7: The entry of the term GRABBA into pop culture vernacular postdates my use of the GRABBA LEAF trademarks.³⁷⁴

The Board observed that “[w]hether Petitioner was the first user of the term is irrelevant, since we evaluate the question of whether a term is merely descriptive as of the time of trial.”³⁷⁵

The petitioner further admitted in his trial brief that “[o]nly after Robinson, have second comers and junior users adopted the GRABBA term as part of a trademark, or worse, *to describe* a tobacco cigar wrap product.”³⁷⁶ The Board considered these statements to be admissions that “grabba” is “currently viewed by the relevant public as, at a minimum, immediately conveying information about an ingredient or characteristic of tobacco, or tobacco products, including cigar wraps.”³⁷⁷

[C]onsidering all the evidence of record, we find that the term “GRABBA LEAF,” when viewed in relation to Petitioner’s “cigar wraps,” immediately conveys information about them, namely that they may be used as a leaf to wrap grabba tobacco, or that grabba leaf tobacco is an ingredient in the cigar wraps.³⁷⁸

The Board found that Robinson’s word-plus-design mark, which includes a drawing of a tobacco leaf, engenders the same commercial impression as the word mark GRABBA LEAF and is likewise merely descriptive of cigar wraps.

The Board therefore granted the counterclaim for cancellation of Robinson’s pleaded registrations. Moreover, since Robinson had no rights in the mark GRABBA LEAF, his claim under Section 2(d) also failed, and so the Board denied his petition for cancellation.

3. Section 2(f) Acquired Distinctiveness

Performance Open Wheel Racing, Inc. v. U.S. Auto Club Inc.

Finding Applicant United States Auto Club’s (“USAC”) evidence of acquired distinctiveness inadequate, the Board sustained this opposition to registration of the mark NATIONAL MIDGET SERIES for “entertainment services, namely, arranging and conducting automobile racing events; and sanctioning, supervising, and officiating of automobile races” [SERIES disclaimed] on the

³⁷⁴ *Id.* at *18. Interestingly, the declaration was inadmissible because it was not signed during Robinson’s testimony period, but statements made in the declaration were deemed admissions against interest and were considered by the Board.

³⁷⁵ *Id.* at *19. *See Grote Indus., Inc. v. Truck-Lite Co.*, 126 U.S.P.Q.2d 1197, 1211 (T.T.A.B. 2018) (citing *Neapco Inc. v. Dana Corp.*, 12 U.S.P.Q.2d 1746, 1747 (T.T.A.B. 1989)).

³⁷⁶ *Id.*

³⁷⁷ *Id.* at *20.

³⁷⁸ *Id.*

ground of mere descriptiveness. Applicant USAC asserted a *Morehouse* defense³⁷⁹ based on its ownership of a registration for the mark NATIONAL MIDGET CHAMPIONSHIP for the same services, but the Board pointed out that this “prior registration” defense is not available on the issue of whether a descriptive mark has acquired distinctiveness.³⁸⁰

Because Applicant USAC sought registration under Section 2(f) of the Lanham Act, the applicant “conceded that NATIONAL MIDGET SERIES is merely descriptive.”³⁸¹ The Board found the term to be “highly descriptive,” concluding that the mark “as a whole is even more descriptive of Applicant’s identified services than its individual components standing alone.”³⁸² USAC’s burden to establish acquired distinctiveness was therefore “commensurately high.”³⁸³

USAC relied on evidence of use of the phrase since 1956, its sanctioning of events in nearly every state, recognition by major sports publications, television broadcasts with about 700 active subscribers and 15,000 views per month, more than two million Facebook views, fan support, and strategic partnerships with Oakley, Toyota, and AMSOIL. Not enough, said the Board.

USAC’s long use of the phrase was not dispositive of the issue. Opposer Open Wheel Racing has sanctioned NATIONAL MIDGET SERIES events since 2004, and has co-sanctioned events with Applicant USAC. Third-party witnesses confirmed that Open Wheel Racing has used the phrase for the same services since 2004, weighing against a finding that USAC’s use was substantially exclusive, as required by Section 2(f).

Moreover, USAC’s evidence regarding the number of events it sanctioned was unclear, and the proof of the number of fans who attended the races was ambiguous. Its advertising expenditures were *de minimis*, and there was no evidence as to how it advertised. USAC provided no context for its social media advertising and its evidence of media recognition was unconvincing. Finally, the number of television subscribers was “relatively small,” and there

³⁷⁹ *Morehouse Mfg. Corp. v. J. Strickland Co.*, 407 F.2d 881, 160 U.S.P.Q. 715, 717 (C.C.P.A. 1969). The *Morehouse* defense is based on the proposition that a party cannot be damaged by issuance of a second registration if the other party already owns a registration for the same mark for the same goods or services. In this author’s experience, the *Morehouse* defense is almost never accepted.

³⁸⁰ *Performance Open Wheel Racing, Inc. v. U.S. Auto Club Inc.*, 2019 U.S.P.Q.2d 208901 (T.T.A.B. 2019). The Board dismissed petitioner’s genericness claim, discussed in Part II.B.6, below.

³⁸¹ *Id.* at *19, citing *Royal Crown*, 127 U.S.P.Q.2d at 1044-45. However, in this author’s view, the applicant conceded only that the mark is not *inherently* distinctive, and not that it is descriptive.

³⁸² *Id.* at *20.

³⁸³ *Id.*

was no evidence regarding how many viewers watched the live (non-subscription) broadcasts of the events.³⁸⁴

Weighing all the evidence, the Board found that Applicant USAC failed to meet its burden of proof to establish acquired distinctiveness.

Morehouse Defense: This “prior registration” defense is an equitable defense “analogous to laches or acquiescence,” and it is not available in proceedings “predicated on whether a merely descriptive mark has acquired distinctiveness because of the overriding public interest in precluding the registration of a merely descriptive designation.”³⁸⁵ End of story.

4. Abandonment

TV Azteca, S.A.B. de C.V. v. Martin

Under a recently established USPTO pilot program “to explore procedures for expediting certain cancellation proceedings to further the USPTO’s goal of maintaining the accuracy and integrity of the U.S. Trademark Register,”³⁸⁶ the Board initiated an “expedited cancellation” proceeding against Jeffrey E. Martin’s registration for the mark MYST (in stylized form) for “entertainment services, namely live performances by a musical group.” However, Petitioner TV Azteca failed to establish a prima facie case of abandonment based on its pleaded claim of nonuse during the three-year period immediately preceding the filing of the petition to cancel, and the Board accordingly dismissed the petition.³⁸⁷

Procedure: This new expedited cancellation procedure is initiated by the Board. Under the program, the Board identifies cancellation cases that have not resulted in disposition by default and in which the only claims are abandonment, nonuse, or both. Cases with counterclaims are ineligible. Once a case is identified as a candidate for the expedited cancellation program, the Board participates in the parties’ discovery conference to discuss voluntary stipulation to one or more of the Board’s several Accelerated Case Resolution (“ACR”) options, including pretrial final disposition on the merits or abbreviated trial on the merits.³⁸⁸

³⁸⁴ *Id.* at *28.

³⁸⁵ *Id.* at *30. The Board also noted that the *Morehouse* defense does not apply if the marks are not “essentially the same.” Here, NATIONAL MIDGET SERIES and NATIONAL MIDGET CHAMPIONSHIP are “materially different marks.” *Id.* n. 67.

³⁸⁶ This “Expedited Cancellation Pilot Program” is described on the USPTO website, here: <https://www.uspto.gov/trademarks-application-process/trademark-trial-and-appeal-board/expedited-cancellation-pilot-program>.

³⁸⁷ *TV Azteca, S.A.B. de C.V. v. Martin*, 128 U.S.P.Q.2d 1786 (T.T.A.B. 2018).

³⁸⁸ See TBMP §§ 528.05(a)(2) (2018) and 702.04.

Here, the parties consented to litigate the case as an expedited cancellation proceeding. They agreed to exchange initial disclosures but dispense with formal discovery.³⁸⁹ Both parties filed testimony and documentary evidence along with their respective main briefs, and the petitioner filed a rebuttal brief.³⁹⁰

Abandonment: As the sole ground for cancellation, Petitioner TV Azteca alleged that Respondent Martin abandoned his MYST mark by discontinuing its use “for at least three years [from March 2015 to March 2018] preceding the filing of this Petition to Cancel,” with no intent to resume use.³⁹¹

Under Section 45 of the Lanham Act, 15 U.S.C. § 1127, a mark is deemed abandoned “[w]hen its use has been discontinued with intent not to resume such use. Intent not to resume may be inferred from circumstances. Nonuse for 3 consecutive years shall be prima facie evidence of abandonment.”³⁹²

A registration is presumed valid³⁹³ and therefore the party seeking cancellation bears the burden of proving abandonment by a preponderance of the evidence.³⁹⁴ If the petitioner presents a prima facie case of abandonment, the burden of production, i.e., of going forward, then shifts to the trademark holder to rebut the prima facie showing with evidence of either: (1) use of the mark during the statutory period; or (2) an intent to resume use.³⁹⁵ The burden of persuasion, however, always remains with the petitioner.³⁹⁶

Respondent Martin, appearing pro se, submitted several documents bearing the word “MYST,” but many were undated and none were dated during the March 2015 to March 2018 time period at issue. He also submitted an unsworn and, therefore, nonprobative statement regarding those documents. Thus, Martin

³⁸⁹ This author suggests that the petitioner’s agreement not to take formal discovery meant that it had to have a “smoking gun” already in hand in order to prove abandonment.

³⁹⁰ *TV Azteca*, 128 U.S.P.Q.2d at 1787.

³⁹¹ *Id.* at 1788.

³⁹² *Id.* at 1789.

³⁹³ See *Yazhong Investing Ltd. v. Multi-Media Tech. Ventures, Ltd.*, 120 U.S.P.Q. 1526, 1532 (T.T.A.B. 2018); see also *On-Line Careline Inc. v. Am. Online Inc.*, F.3d 1080, 56 U.S.P.Q.2d 1471, 1476 (Fed. Cir. 2000); *Exec. Coach Builders, Inc. v. SPV Coach Co.*, 123 U.S.P.Q.2d 1175, 1180-81 (T.T.A.B. 2016).

³⁹⁴ Section 7(b) of the Lanham Act, 15 U.S.C. § 1057(b), states:

A certificate of registration of a mark upon the principal register provided by this chapter shall be prima facie evidence of the validity of the registered mark and of the registration of the mark, of the owner’s ownership of the mark, and of the owner’s exclusive right to use the registered mark in commerce on or in connection with the goods or services specified in the certificate, subject to any conditions or limitations stated in the certificate.

³⁹⁵ *TV Azteca*, 128 U.S.P.Q.2d at 1789.

³⁹⁶ *Id.* See *Rivard v. Linville*, 133 F.3d 1446, 45 U.S.P.Q.2d 1374, 1376 (Fed. Cir. 1998); *Cerveceria Centroamericana S.A. v. Cerveceria India Inc.*, 892 F.2d 1021, 13 U.S.P.Q.2d 1307, 1311 (Fed. Cir. 1989).

failed to establish use of the MYST mark during the relevant period, but TV Azteca had the initial burden to show that Martin *did not* use his mark during that period. In short, TV Azteca faced the unenviable task of trying to prove a negative.

TV Azteca focused on one particular document that had a partial date—namely, a flyer promoting a “MYST” concert on “March 25th” [no year specified] at a venue called the Pennant East in Bellmawr, New Jersey—and attempted to prove that the venue Pennant East had closed in 2011 and thus Martin could not have appeared there during the relevant time period.

TV Azteca submitted six newspaper articles and a blog post discussing the closing of Pennant East, but Martin objected to these items as inadmissible hearsay. TV Azteca invoked the “residual hearsay” exception of Fed. R. Evid. 807(a) for statements that have “equivalent circumstantial guarantees of trustworthiness” analogous to those of a public record and are “more probative on the point for which it is offered than any other evidence that the proponent can obtain through reasonable efforts.”³⁹⁷ The Board, noting that the residual hearsay exception is intended to “be used only rarely, in truly exceptional cases,”³⁹⁸ was unmoved: “Even assuming no reasonable effort could have discovered more probative evidence, the articles and blog post do not possess ‘circumstantial guarantees of trustworthiness’ equivalent to official records or witness testimony.”³⁹⁹ The Board therefore sustained the respondent’s objection to the news articles and blog post.

TV Azteca also pointed to several official records in an attempt to show that Pennant East closed its doors in 2011. Again, the Board was unimpressed:

These records do not support Petitioner’s contention that Pennant East closed. Even if Pennant East twice lost its liquor license, that alone does not establish that the premises were shuttered, did not move elsewhere, or did not continue operating as an alcohol-free establishment or in violation of the licensing laws. Furthermore, even if the evidence could suggest that Pennant East closed in 2011, it is at best inconclusive as to whether Respondent discontinued use of his mark from March 2015 to March 2018.⁴⁰⁰

The Board closed the door on Petitioner TV Azteca, ruling that it had failed to establish a *prima facie* case of abandonment because

³⁹⁷ *Id.* at 1790-91.

³⁹⁸ *Id.* at 1791, quoting *Pozen Inc. v. Par Pharm. Inc.*, 696 F.3d 1151, 104 U.S.P.Q.2d 1969, 1976 n.6 (Fed. Cir. 2012) (applying Fifth Circuit law and citing *United States v. Walker*, 410 F.3d 754, 757 (5th Cir. 2005)).

³⁹⁹ *Id.*

⁴⁰⁰ *Id.*

it failed to prove non-use during the claimed three-year period prior to the filing of the petition for cancellation.

We recognize that in attempting to prove a negative, as in proving abandonment through nonuse, “without resort to proper inferences the burdened party could be faced with an insurmountable task.” *Cerveceria Centroamericana*, 13 U.S.P.Q.2d at 1310. But even in expedited proceedings, inferences must be based on proven foundational facts. Here, drawing all reasonable inferences available based on the evidence presented by Petitioner or contained in Respondent’s initial disclosures, we find that Petitioner has failed to establish a prima facie case of Respondent’s non-use.⁴⁰¹

5. Dilution

TiVo Brands, LLC v. Tivoli, LLC

In a rare dilution decision, the Board sustained TiVo’s oppositions to registration of TIVOTAPE and TIVOBAR for electric lighting fixtures and related goods, finding the marks likely to dilute by blurring the famous TIVO mark for computer hardware and software. The Board found that the TIVO mark had become famous before Applicant Tivoli’s first use dates, and remained famous at the time of trial.⁴⁰²

TiVo pioneered the creation and development of the digital video recorder or “DVR” in 1999. Applicant Tivoli entered the lighting business in 1972 and owns registrations for TIVOLI, TIVOLED, TIVOFLEX, and TIVOLITE for lighting fixtures, controllers, and LED lights. It also claimed common law rights in the marks TIVOFLUTE, TIVOFLEX, TIVOCOVE, TIVOCUE, and TIVOGRAZE for lighting goods. Tivoli first used the TIVOTAPE mark on May 30, 2010, and TIVOBAR on September 21, 2015.

To establish a claim for dilution by blurring under Section 43(c) of the Lanham Act, a plaintiff must plead and prove the following:

1. The plaintiff owns a famous mark that is distinctive;
2. The defendant is using a mark in commerce that allegedly dilutes plaintiff’s famous mark;
3. The defendant’s use of its mark began after plaintiffs [sic] mark became famous; and
4. The defendant’s use of its mark is likely to cause dilution by blurring.⁴⁰³

⁴⁰¹ *Id.*

⁴⁰² *TiVo Brands, LLC v. Tivoli, LLC*, 129 U.S.P.Q.2d 1097 (T.T.A.B. 2018).

⁴⁰³ *Id.* at 1103, citing *Nike, Inc. v. Palm Beach Crossfit Inc.*, 116 U.S.P.Q.2d 1025 (T.T.A.B. 2015).

The Board narrowed its focus to the opposer's use and registration of the mark TIVO, both with and without its design element, for its DVR product, since this is the product that allegedly had achieved dilution fame.

In order to prove that a mark is famous, a party "must show that, when the general public encounters the mark 'in almost any context, it associates the term, at least initially, with the mark's owner.'"⁴⁰⁴ In this regard, the Board may consider all relevant factors, including the following listed in Section 43(c)(2)(A):

(i) The duration, extent, and geographic reach of advertising and publicity of the mark, whether advertised or publicized by the owner or third parties.

(ii) The amount, volume, and geographic extent of sales of goods or services offered under the mark.

(iii) The extent of actual recognition of the mark.

(iv) Whether the mark was registered under the Act of March 3, 1881, or the Act of February 20, 1905, or on the principal register.⁴⁰⁵

"Perhaps the most significant of the four elements set forth in the Act to determine fame is the extent of actual public recognition of the mark as a source-indicator for the goods or services in connection with which it is used."⁴⁰⁶ The Board found that third-party recognition of the TIVO mark "tips the balance" in favor of finding the mark to be famous for dilution purposes.⁴⁰⁷ The evidence showed that the TIVO mark was referenced in major news and entertainment outlets, and by politicians and celebrities, since January 2000. The Board therefore found that, by 2010, "the extent of actual recognition of the mark was pervasive and widespread"⁴⁰⁸ and TIVO had become a "household term [with] which almost everyone is familiar."⁴⁰⁹

Tivoli argued that TiVo should be required to prove fame as of 1971, when Tivoli began using its TIVOLI mark, from which its later TIVO-formative marks are derived. The Board noted that the dilution statute, when referring to the defendant's first use of its mark, does not limit the use to the goods in the subject application, but the "involved" mark may not change over time. "[I]n order for the defendant to 'tack' on its earlier use, the mark must be essentially the same at the time it is first used as at the time when

⁴⁰⁴ *Id.*, citing *Coach Servs.*, 101 U.S.P.Q.2d at 1725 (Fed. Cir. 2012) (quoting *Toro Co. v. ToroHead Inc.*, 61 U.S.P.Q.2d 1164, 1180-81 (T.T.A.B. 2001)).

⁴⁰⁵ *Id.* See 15 U.S.C. § 1125(e)(2)(A).

⁴⁰⁶ *Id.* at 1104, citing *Nike Inc. v. Maher*, 100 U.S.P.Q.2d 1018, 1024 (T.T.A.B. 2011).

⁴⁰⁷ *Id.* at 1104.

⁴⁰⁸ *Id.* at 1111.

⁴⁰⁹ *Id.* at 1112, quoting *Toro Co.*, 61 U.S.P.Q.2d at 1181.

it is used in association with the goods or services identified in the subject application or registration.”⁴¹⁰ Here, the marks changed over time, and so tacking was not permitted.

The Board also considered whether a plaintiff alleging dilution must show that its mark is famous at the time of trial, finding this to be an issue of first impression. The Board concluded that the answer is yes.

To find otherwise would allow a mark that has lost its fame to continue to enjoy the widest penumbra of protection available accorded by the extraordinary protection of the dilution statute. This approach also accounts for any significant changes in the marketplace between the date of Applicant’s first use of its mark and trial.⁴¹¹

The Board found that the TIVO mark was famous both as of 2010 and at the time of trial.

Turning to the issue of whether the applied-for marks dilutes the TIVO marks, the Board considered the six non-exclusive factors set forth in Section 43(c)(2)(B)(i)-(vi).⁴¹²

As to the similarity of the marks, the Board applied the same test as in the Section 2(d) context: “the similarity or dissimilarity of the marks in their entireties as to appearance, sound, connotation and commercial impression.”⁴¹³ It found that the first and distinctive term “TIVO” dominates the applicant’s marks because consumers are less likely to focus on the descriptive portions “TAPE” and “BAR.” The similarity between the involved marks is sufficient to “‘trigger consumers to conjure up’ Opposer’s famous mark and associate Applicant’s marks with Opposer’s mark.”⁴¹⁴

The Board found that TIVO is inherently distinctive for TiVo’s goods and services, and that TiVo is the substantially exclusive user of the mark. Tivoli relied on a number of third-party registrations, but none was for the mark TIVO alone, and there was no proof that

⁴¹⁰ *Id.*

⁴¹¹ *Id.* at 1113.

⁴¹² Section 43(c)(2)(B) of the Lanham Act, 15 U.S.C. § 1125(c)(2)(B), provides that:

“[D]ilution by blurring” is association arising from the similarity between a mark or trade name and a famous mark that impairs the distinctiveness of the famous mark. In determining whether a mark or trade name is likely to cause dilution by blurring, the court may consider all relevant factors, including the following: (i) The degree of similarity between the mark or trade name and the famous mark; (ii) The degree of inherent or acquired distinctiveness of the famous mark; (iii) The extent to which the owner of the famous mark is engaging in substantially exclusive use of the mark; (iv) The degree of recognition of the famous mark; (v) Whether the user of the mark or trade name intended to create an association with the famous mark; and (vi) Any actual association between the mark or trade name and the famous mark.

⁴¹³ *Id.* at 1115, quoting *Nike*, 100 U.S.P.Q.2d at 1030.

⁴¹⁴ *Id.* at 1116, citing *Nike*, 100 U.S.P.Q.2d at 1030 (quoting *Nat’l Pork Bd. v. Supreme Lobster and Seafood Co.*, 96 U.S.P.Q.2d 1479, 1497 (T.T.A.B. 2010)).

any of the third-party marks are in use. Tivoli also argued that its own marks show the weakness of the TIVO mark, but the Board was not persuaded because “they are not for TIVO alone and too few in number to show that Opposer’s use is not substantially exclusive.”⁴¹⁵

As to the factor that requires a determination as to the level of fame, the Board observed that “the likelihood of an association between the famous mark and the defendant’s mark [is] proportional to the extent of the mark’s fame.”⁴¹⁶ Opposer TiVo’s evidence of fame mostly concerned the years before 2010, and the Board inferred that the “degree of consumer recognition has somewhat weakened over time.”⁴¹⁷ Nonetheless, it found that TIVO is publicly associated with the opposer’s digital video recorders such that it “is now primarily associated with the owner of the mark even when it is considered outside of the context of the owner’s goods and services.”⁴¹⁸

There was no evidence that Applicant Tivoli intended to create an association with the TIVO mark, no evidence of an actual association between the applied-for marks and the TIVO mark, and no evidence of actual public association between them.

Viewing the entire record, the Board concluded that the applied-for marks TIVOTAPE and TIVOBAR are likely to dilute the distinctive quality of the famous mark TIVO, and so the Board sustained the oppositions.

6. Genericness

Performance Open Wheel Racing, Inc. v. U.S. Auto Club Inc.

The Board sustained this opposition to registration of the mark NATIONAL MIDGET SERIES, finding it merely descriptive of, but not generic for, “entertainment services, namely, arranging and conducting automobile racing events and sanctioning, supervising, and officiating of automobile races” [SERIES disclaimed].⁴¹⁹

As to the genericness issue, the Board found the pertinent genus to be defined by the applicant’s recitation of services, a genus that includes “the subcategory of automobile races for midget racing

⁴¹⁵ *Id.* at 1117.

⁴¹⁶ *Id.*

⁴¹⁷ *Id.*

⁴¹⁸ *Id.*, quoting *Toro Co.*, 61 U.S.P.Q.2d at 1180-81.

⁴¹⁹ *Performance Open Wheel Racing, Inc. v. U.S. Auto Club Inc.*, 2019 U.S.P.Q.2d 208901 (T.T.A.B. 2019). The Board upheld the opposer’s Section 2(e)(1) claim, finding the mark “highly descriptive and lacking in acquired distinctiveness.” That issue is discussed in Part II.B.3, above.

cars.”⁴²⁰ The relevant public comprises automobile racing fans, racetrack owners and promoters, professional drivers, midget car owners and builders, and automobile racing associations.⁴²¹ The question, then, was how relevant consumers perceive the term “National Midget Series” when used in connection with the applicant’s services.

The Board observed that the word “national” has generally been found to be descriptive, but it was not convinced by the evidence that the word is generic for the services.⁴²² Although each of the three constituent words, when combined, retains its descriptive or generic meaning in connection with automobile racing services, “not each of those terms has been shown to be generic for the services and, accordingly, we cannot say that the meaning of the whole is generic based on the dictionary definitions alone.”⁴²³

The parties submitted conflicting testimony as to whether “National Midget Series” is a phrase commonly used by other organizations to describe goods or services similar to those of the applicant. The Board, noting that the determination of genericness is a fact-intensive inquiry, found that the record evidence failed to establish that “National Midget Series” is “used or understood by the relevant purchasing public” to refer to the genus of services at issue.⁴²⁴

In this case, Opposer’s witness testimony names only Opposer as another entity in the industry that uses this phrase, and that use is in conjunction with Applicant. Opposer’s witness testimony as to consumer perception is simply conclusory without basis. This unconvincing testimony is further undermined by Applicant’s witnesses who testify the phrase is not used by others. Finally, the use of NATIONAL MIDGET SERIES introduced by Opposer is inconclusive as it could be perceived as trademark use and not as the name of the genus.⁴²⁵

The Board concluded that Opposer Open Wheel Racing had failed to meet its burden of showing, by a preponderance of the

⁴²⁰ *Id.* at *10. According to Wikipedia, “Midget cars . . . is a class of racing cars. The cars are very small with a very high power-to-weight ratio and typically used four cylinder engines.” *Id.* at *6, n.27.

⁴²¹ *Id.* at *10.

⁴²² *Id.* at *12. See *In re Chamber of Commerce of the U.S.*, 675 F.3d 1297, 102 U.S.P.Q.2d 1217 (Fed. Cir. 2012) (NATIONAL CHAMBER merely descriptive of nationwide online directory services featuring information regarding local and state chambers of commerce and business and regulatory data analysis services for nationally promoting the interests of businesspersons or industry); see also TMEP § 1209.03(o) (2018).

⁴²³ *Id.* at *13.

⁴²⁴ *Id.* at *17.

⁴²⁵ *Id.* at *17-18.

evidence, that the relevant public uses or perceives NATIONAL MIDGET SERIES to be generic for the applicant's services.

7. Lack of Bona Fide Intent

A&H Sportswear Co., Inc. v. Yedor

Applicant William W. Yedor never got to first base in his attempt to register the mark MIRACLE ON 35th STREET⁴²⁶ for printed materials and various clothing items. The Board granted Opposer A&H's motion for summary judgment, finding that Yedor lacked a bona fide intention to use the mark on the identified goods at the time of filing his Section 1(b) application.⁴²⁷

The evidentiary burden to establish a bona fide intent to use is not high, but more is required than "a mere subjective belief."⁴²⁸ The objective evidence must indicate an intention that is "firm" and "demonstrable."⁴²⁹ The absence of documentary evidence supporting an applicant's bona fide intention to use the mark in commerce establishes a prima facie case that the applicant lacks such intention. The applicant may overcome the presumption by presenting facts that adequately explain or outweigh its failure to provide documentary evidence.⁴³⁰

Applicant Yedor asserted that he intended to sell T-shirts, owned the domain name whitesoxshirts.com, had one shirt design, gave friends and family a "prototype T-shirt" in 2005 [eleven years before his filing date], and planned to build a website in the event the Chicago White Sox win the World Series.⁴³¹

Yedor produced only one document during discovery, an image of the 2005 t-shirt. He identified no other products that he planned to sell and no classes of purchasers for his goods. He identified no

⁴²⁶ For more than a century, the White Sox have played at 35th Street and Shields Avenue on Chicago's South Side. Hence, the adaptation of the Christmas movie title, "Miracle on 34th Street," to refer to any rare success of the franchise.

⁴²⁷ *A&H Sportswear Co., Inc. v. Yedor*, 2019 U.S.P.Q.2d 111513 (T.T.A.B. 2019). Section 1(b) of the Lanham Act, 15 U.S.C. § 1051(b), provides that "A person who has a bona fide intention, under circumstances showing the good faith of such person, to use a trademark in commerce may request registration of its trademark"

⁴²⁸ *Id.* at *7.

⁴²⁹ *Id.*, citing *M.Z. Berger & Co. v. Swatch AG*, 787 F.3d 1368, 114 U.S.P.Q.2d 1892, 1897-98 (Fed. Cir. 2015); *Swiss Grill Ltd. v. Wolf Steel Ltd.*, 115 U.S.P.Q.2d 2001, 2008 (T.T.A.B. 2015); *see also* *Bos. Red Sox Baseball Club LP v. Sherman*, 88 U.S.P.Q.2d 1581, 1587 (T.T.A.B. 2008); *Lane Ltd. v. Jackson Int'l Trading Co.*, 33 U.S.P.Q.2d 1351, 1355 (T.T.A.B. 1994).

⁴³⁰ *Id.* at *7-8. *See* *Spirits Int'l., B.V. v. S.S. Taris Zeytin Ve Zeytinyagi Tarim Satis Kooperatifleri Birliđi*, 99 U.S.P.Q.2d 1545, 1549 (T.T.A.B. 2011); *Honda Motor Co. v. Winkelmann*, 90 U.S.P.Q.2d 1660, 1662-64 (T.T.A.B. 2009); *L.C. Licensing Inc. v. Berman*, 86 U.S.P.Q.2d 1883, 1891 (T.T.A.B. 2008); *Commodore Elecs. Ltd. v. CBM Kabushiki Kaisha*, 26 U.S.P.Q.2d 1503, 1507 (T.T.A.B. 1993).

⁴³¹ *Id.* at *8. The White Sox last won the World Series in 2005, 88 years after their prior win in 1917.

documents showing use of, or steps toward using, his mark on any products, or showing advertising, promotions, media, marketing plans, business plans, or packaging materials or expenditures. He did not produce documents identifying any outlets, distributors or resellers through which he intended to offer or offers his goods. Furthermore, Yedor stated that he had no documentation of any business or marketing plan, any prospective purchasers, or any websites to display his products.⁴³²

The Board observed that the lack of documentation from the time of filing is “highly probative” of Yedor’s lack of a bona fide intent to use his purported mark at that time.⁴³³

Although evidence that post-dates the filing date may be probative of an applicant’s intent at the time of filing,⁴³⁴ the only document that Yedor produced was dated eleven years before the filing date of his application. Neither the filing of the application nor Yedor’s ownership of the domain name, whitesoxshirts.com, constituted evidence that he had a bona fide intent to use the mark as of the filing date. Yedor did not provide any evidence demonstrating that he engaged in any activities “even somewhat contemporaneous with the February 26, 2016 filing date.”⁴³⁵

Yedor asserted that he planned to launch his business once the legal issue had been resolved and “once the White Sox fan base has something to cheer about—making marketing efforts worthwhile and successful.”⁴³⁶ The Board, however, observed that Yedor’s “hopes are insufficient to show bona fide intent.”⁴³⁷

The Board concluded that Opposer A&H had established the absence of a genuine dispute of material fact regarding Yedor’s lack of the requisite bona fide intent to use his mark at the time of filing his application, that Yedor failed to rebut this prima facie case with any evidence that bears upon his intent to use, and that A&H was entitled to judgment as a matter of law.

⁴³² *Id.* at *8-9.

⁴³³ *Id.* at *9, citing *Honda Motor Co.*, 90 U.S.P.Q.2d at 1664 (Board granted summary judgment sustaining the opposition where the applicant had no documentary evidence to support his asserted intention to use).

⁴³⁴ *Id. See, e.g., Swatch AG v. M.Z. Berger & Co.*, 108 U.S.P.Q.2d 1463, 1474 (T.T.A.B. 2013), *aff’d*, 114 U.S.P.Q.2d 1892 (Fed. Cir. 2015) (documents created seven months after application date were relevant to intent at time of filing), and *Lane Ltd. v. Jackson Int’l Trading Co.*, 33 U.S.P.Q.2d 1351, 1355 (T.T.A.B. 1994) (correspondence that occurred nine to eleven months after filing date was sufficiently contemporaneous).

⁴³⁵ *Id.* at *12.

⁴³⁶ *Id.*

⁴³⁷ *Id. See Lincoln Nat’l Corp. v. Anderson*, 110 U.S.P.Q.2d 1271, 1277 (T.T.A.B. 2014) (an applicant’s “idealistic hopes” to build a business around a mark at some indefinite time in the future do not suffice to show bona fide intent to use).

8. Standing

Australian Therapeutic Supplies Proprietary Ltd. v. Naked TM, LLC

The Board dismissed this petition for cancellation of a registration for the (oxymoronic?) mark NAKED for “condoms,” finding that Petitioner Australian Therapeutic lacked standing because it had agreed not to use or register the mark NAKED for condoms in the United States, and further had agreed that Respondent Naked TM could use and register the mark.⁴³⁸

The Board had already ruled, on cross-motions for summary judgment, that confusion is both likely and inevitable between Australian’s mark and Naked TM’s marks NAKED and NAKED CONDOM for condoms. It advised the parties “to focus their efforts at trial on the issues of standing (i.e., whether or not Petitioner is contractually estopped from asserting a ‘real interest’ as a basis for damage or maintaining this cancellation action) and priority.”⁴³⁹ The Board noted that the defense of contractual estoppel—unlike Naked TM’s defenses of laches, acquiescence, and equitable estoppel—is not “negated by inevitable confusion.”⁴⁴⁰

Only the defense of equitable estoppel is negated by inevitable confusion . . . [T]he issue of contractual estoppel is effectively a threshold inquiry into whether or not the parties entered into an enforceable agreement such that Petitioner now lacks a “real interest” in seeking cancellation of Respondent’s registration or has “contracted away” its right to seek cancellation.⁴⁴¹

Respondent Naked TM contended that Australian had contracted away its standing—i.e., its “real interest” in the proceeding—when the parties agreed that Australian would use and register NUDE for condoms while Naked TM would use and register NAKED for condoms.

The TTAB observed that, although it is empowered to determine only the right to register a mark, it “may consider the terms of a contract if, and to the extent that, construction of the contract is necessary to a decision on matters within the Board’s

⁴³⁸ *Australian Therapeutic Supplies Pty. Ltd. v. Naked TM, LLC*, 129 U.S.P.Q.2d 1027 (T.T.A.B. 2018).

⁴³⁹ *Id.* at 1028-29. To establish standing in an opposition or cancellation proceeding, a plaintiff must prove that it has “both a ‘real interest’ in the proceedings as well as a ‘reasonable’ basis for its belief of damage.” *Id.* at 1030. See *Empresa Cubana Del Tabaco v. Gen. Cigar Co.*, 753 F.3d 1270, 111 U.S.P.Q.2d 1058, 1062 (Fed. Cir. 2014); *Ritchie v. Simpson*, 170 F.3d 1092, 50 U.S.P.Q.2d 1023, 1025 (Fed. Cir. 1999); *Lipton Indus., Inc. v. Ralston Purina Co.*, 670 F.2d 1024, 213 U.S.P.Q. 185, 189 (T.T.A.B. 1982).

⁴⁴⁰ *Id.* at 1028, n.10.

⁴⁴¹ *Id.*

jurisdiction.”⁴⁴² Moreover, “[u]nder certain circumstances a consent to register a mark may be implied from a consent to use the mark.”⁴⁴³

Here, there was no formal written agreement, but the Board recognizes oral and informal agreements.⁴⁴⁴ It reviewed “the relevant actions and communications between the parties to determine whether the parties had reached an agreement regarding their respective use and registration of the NAKED trademark.”⁴⁴⁵ The communications were by email. The Board found that:

Petitioner’s actions and communications led Respondent to believe that the parties agreed that Petitioner would not use or register the mark NAKED in connection with condoms in the United States and that Respondent could use and register the mark NAKED in the United States. Specifically,

- In the April 4, 2007, email exchange Petitioner wrote [N]o need to put anything on paper. Just makes lawyers a lot of money. We no longer have any Naked condoms in the USA, so it should be clear sailing for you. Good luck with the launch.

Thus, Petitioner expressly stated that it no longer had any NAKED condoms in the United States. But more telling, Petitioner did not inform Respondent that it had any plans to continue selling NAKED condoms in the United States via the Internet from Australia;

- In the March 2011 email exchange regarding the confusion caused by Petitioner’s use of the NAKED trademark on its TWITTER account, when Respondent thanked Petitioner “for discontinuing your sub brand naked,” Petitioner did not correct Respondent and explain that Petitioner believed it retained the right to sell NAKED brand condoms in the United States via the Internet.

⁴⁴² *Id.* at 1031. *See Selva & Sons, Inc. v. Nina Footwear, Inc.*, 705 F.2d 1316, 217 U.S.P.Q. 641, 647 (Fed. Cir. 1983); *M-5 Steel Mfg. Inc. v. O’Hagin’s Inc.*, 61 U.S.P.Q.2d 1086, 1094-95 (T.T.A.B. 2001); *see also Renaissance Rialto Inc. v. Boyd*, 107 U.S.P.Q.2d 1083, 1086 (T.T.A.B. 2013) (interpreting contract to find no transfer of rights such as would allow named opposer to bring opposition).

⁴⁴³ *Id. See, e.g., Richdel, Inc. v. Mathews Co.*, 190 U.S.P.Q. 37, 41-42 (T.T.A.B. 1976); *CBS, Inc. v. Man’s Day Publ’g Co., Inc.*, 205 U.S.P.Q.2d 470, 476 (T.T.A.B. 1980) (dismissing opposition because opposer consented to and encouraged applicant’s use of the mark MAN’S DAY).

⁴⁴⁴ *Id. See, e.g., Nestle Co. Inc. v. Nash-Finch Co.*, 4 U.S.P.Q.2d 1085 (T.T.A.B. 1987) (written license not required); *John Anthony, Inc. v. Fashions by John Anthony, Inc.*, 209 U.S.P.Q. 517 (T.T.A.B. 1980) (oral license between employer and former employee).

⁴⁴⁵ *Id.*

- As of September 3, 2011, Petitioner abandoned application Serial No. 78528237 for the mark NAKED CONDOMS; and
- Throughout all of the communications between Petitioner and Respondent, Petitioner never stated or reminded Respondent that Petitioner was retaining the right to sell NAKED condoms in the United States via Internet sales from Australia.⁴⁴⁶

The Board concluded that the parties had reached an agreement.

The mutuality of intent to contract is satisfied because the parties recognized their trademark issue and they communicated and exchanged offers to resolve it. The consideration for the contract is Petitioner's agreement not to use or register the NAKED trademark for condoms in the United States and Respondent's agreement not to use or register the NUDE trademark for condoms. Finally, the lack of ambiguity in offer and acceptance is evidenced by the facts that Petitioner stopped using the NAKED mark in the United States, Petitioner did not interfere with Respondent's use and registration of the NAKED mark in the USPTO, Petitioner registered the NUDE trademark in the United States, and Respondent did not interfere with Petitioner's use and registration of the NUDE trademark in the USPTO.⁴⁴⁷

The Board found the "only reasonable interpretation of the entirety of the communications" to be that Petitioner Australian agreed not to use the NAKED trademark in connection with condoms in the United States via Internet sales.⁴⁴⁸ It therefore concluded that Petitioner Australian failed to prove that it had standing to cancel the subject registration because it lacked a real interest in the proceeding or a reasonable basis for its belief of damage, "having contracted away its right to use and register NAKED and by extension NAKED CONDOMS."⁴⁴⁹

9. Concurrent Use

Scott Stawski v. John Gregory Lawson

Concluding that Applicant Scott Stawski was not entitled to concurrent use registrations for the marks PROSPER ESTATE and PROSPER RIDGE for wines, the Board dissolved this concurrent use proceeding. Stawski claimed rights to his marks in nine states,

⁴⁴⁶ *Id.* at 1034.

⁴⁴⁷ *Id.*

⁴⁴⁸ *Id.* at 1036.

⁴⁴⁹ *Id.*

as an exception to John Gregory Lawson’s registration for the mark PROSPER for wines, but Stawski failed to show prior, lawful use of his marks, and also failed to prove that confusion is not likely.⁴⁵⁰

To obtain the desired concurrent use registrations for his marks, Applicant Stawski was required to show (1) that he made lawful use of the marks in commerce before February 29, 2012 (the filing date of the application that issued as Lawson’s registration), and (2) that the concurrent use of his two marks with Lawson’s mark is not likely to cause confusion.⁴⁵¹

Stawski had to prove “technical use of his trademarks” in commerce prior to Registrant Lawson’s February 29, 2012, filing date: i.e., use sufficient to support a trademark registration.⁴⁵² Priority was not the issue; the question was whether Stawski could satisfy the jurisdictional requirement for a concurrent registration. “[E]vidence of analogous use, as opposed to technical trademark use, which could be considered when establishing priority for the purposes of likelihood of confusion, will not be considered in this concurrent use proceeding.”⁴⁵³

The Lanham Act’s concurrent use provision expressly requires “lawful use in commerce” prior to the filing date of an excepted user’s application or registration.⁴⁵⁴ “Use in commerce” means “the bona fide use of a mark in the ordinary course of trade, and not made merely to reserve a right in a mark.”⁴⁵⁵ Applicant Stawski failed to establish that his use was “in commerce,” and likewise failed to prove that, if his use was in commerce, it was lawful. Thus, he failed to meet the jurisdictional requirement of Section 2(d).

Use in Commerce: Stawski’s mere selection of his trademarks in 2007 did not constitute use of the marks in commerce,⁴⁵⁶ nor did his 2007 registration of “Prosper Estate Vineyards” as an assumed business name,⁴⁵⁷ or his 2007 registration of PROSPER-formative

⁴⁵⁰ *Stawski v. Lawson*, 129 U.S.P.Q.2d 1036 (T.T.A.B. 2018).

⁴⁵¹ *Id.* at 1038.

⁴⁵² *Id.* at 1039.

⁴⁵³ *Id.*

⁴⁵⁴ 15 U.S.C. § 1052(d).

⁴⁵⁵ 15 U.S.C. § 1127.

⁴⁵⁶ *Stawski*, 129 U.S.P.Q.2d at 1044. *See, e.g.*, *Hydro-Dynamics Inc. v. George Putnam & Co. Inc.*, 811 F.2d 1470, 1 U.S.P.Q.2d 1772, 1774 (Fed. Cir. 1987):

A right of ownership in and to a mark arises from prior use of said mark in connection with a particular product or service and not from prior adoption alone. A mark has no existence apart from any product or service, and hence the mere adoption of a word or symbol does not without more confer upon the adopter thereof the right of ownership.

⁴⁵⁷ *Id.* at 1045. *See In re Leticia Corp.*, 226 U.S.P.Q. 276, 277 (T.T.A.B. 1985) (“trade names qua trade names do not qualify for registration.”).

domain names, or his 2009 registration of domain names that connect to a website.⁴⁵⁸

Stawski knew that his grapevines would not mature for ten years after their planting in 2008, and knew that his vineyard would not become the source of commercially marketable wine for more than a decade. Although he did not have a product ready to market, Stawski attempted “to establish the reputation and brand identity of the vineyard and the Prosper Estate and Prosper Ridge wine labels” by placing the labels on bottled wine purchased from a third party.⁴⁵⁹ However, critical details and corroboration regarding those purchases was lacking, and there was no evidence that Stawski made any sales to customers. The Board noted that, “[w]hile actual sales are not required for statutory use in commerce, . . . in the context of test marketing, whether the goods are sold can help inform whether the activity is in the ordinary course of trade.”⁴⁶⁰ The Board deemed Stawski’s evidence regarding the distribution of samples to be “vague, equivocal, mostly undated.”⁴⁶¹ In short, he failed to prove bona fide use in the ordinary course of trade.

The Board found that Stawski’s placement of labels on wine ordered from the third-party vintner served “merely as a placeholder, until he had a product ready to market.”⁴⁶² His minimal distribution under the private labels “tacitly acknowledges that his ‘activity was preliminary and exploratory, and [he] was not yet ready to introduce the product in the ordinary course of trade.’”⁴⁶³

The Board concluded that Applicant Stawski had failed to carry his burden of proving prior use in commerce.

Lawful Use: Registrant Lawson further contended that Stawski’s purported use of his marks was not lawful because Stawski did not comply with the regulations promulgated by the Alcohol and Tobacco Tax and Trade Bureau (“TTB”) concerning the labeling of wine that is introduced into interstate commerce.⁴⁶⁴ More

⁴⁵⁸ *Id.* See *In re Quantum Foods, Inc.*, 94 U.S.P.Q.2d 1375, 1378-79 (T.T.A.B. 2010):

However, an Internet web page that merely provides information about the goods, but does not provide a means of ordering them, is viewed as promotional material, which is not acceptable to show trademark use on goods. . . . It long has been held that mere advertising is not sufficient to show trademark use.

⁴⁵⁹ *Id.*

⁴⁶⁰ *Id.*, quoting *Tao Licensing, LLC v. Bender Consulting Ltd.*, 125 U.S.P.Q.2d 1043, 1054 (T.T.A.B. 2017) (internal citations omitted).

⁴⁶¹ *Id.* at 1046.

⁴⁶² *Id.*

⁴⁶³ *Id.*, quoting *Tao Licensing*, 125 U.S.P.Q.2d at 1054.

⁴⁶⁴ Regulations are promulgated by the TTB under the authority of the Federal Alcohol Administration Act, 27 U.S.C. § 201 et seq., including regulations relating to the labeling of wine, which apply to those filling various roles in the wine-making and distribution industry. 27 C.F.R. § 4.1. One regulation states that: “No person shall bottle or pack wine, other than wine bottled or packed in U.S. Customs custody, or remove such wine

specifically, Stawski (as he admitted) did not obtain from the TTB the required Certificate of Label Approval (“COLA”) for his wines.

The Board therefore ruled that, because Stawski did not obtain prior COLA approval, he could not prove that his use of the marks was lawful, as required by Section 2(d).

Likelihood of Confusion: For the sake of completeness, the Board went on to consider the issue of likelihood of confusion. Under Section 2(d), a concurrent use registration may issue only when:

[C]onfusion, mistake, or deception is not likely to result from the continued use by more than one person of the same or similar marks under conditions and limitations as to the mode or place of use of the marks or the goods on or in connection with which such marks are used⁴⁶⁵

Applying the relevant *du Pont* factors, the Board found that Stawski’s addition of the nondistinctive geographic elements “RIDGE” and “ESTATE” to the registered mark PROSPER did not diminish the strong similarity between the marks.

Stawski argued that Lawson’s channels of trade are limited because Lawson had few assets and is unlikely to expand his business. The Board found that discussion to be premature.

In a concurrent use proceeding, however, consideration of the parties’ respective wherewithal, business activity, and planned expansion, among other factors, is relevant only in determining the extent of their respective geographic territories. *See, e.g.,* *Boi Na Braza, LLC v. Terra Sul Corp.*, 110 U.S.P.Q.2d 1386, 1394 (T.T.A.B. 2014) (listing factors, and citing *Weiner King, Inc. v. The Weiner King Corp.*, 615 F.2d 512, 204 U.S.P.Q. 820, 830 (C.C.P.A. 1980)). We do not reach those factors unless and until the applicant carries his burden of proving the two conditions precedent: that there was prior lawful use in commerce and that the geographic territorial division he proposes would be likely to avoid consumer confusion.⁴⁶⁶

Since Lawson’s registration is geographically unrestricted, the Board must consider him “as having rights to use his mark in the entire United States, but for that territory where Applicant could show actual use prior to Registrant’s filing date.”⁴⁶⁷

Because the involved goods are identical, the Board must presume that they would be marketed to the same classes of customers—ordinary adult wine drinkers and purchasers—through

from the plant where bottled or packed, unless an approved certificate of label approval, TTB Form 5100.31, is issued by the appropriate TTB officer.” 27. C.F.R. § 4.50(a).

⁴⁶⁵ 15 U.S.C. § 1052(d).

⁴⁶⁶ *Stawski*, 129 U.S.P.Q.2d at 1053.

⁴⁶⁷ *Id.*

the same channels of trade.⁴⁶⁸ Moreover, there are no limitations as to price or quality, and so there is no reason to believe that purchasers would be particularly discriminating or careful in distinguishing the parties' products.

The question, then, was whether a geographical restriction would suffice to prevent confusion. In this regard, the Board considered two ways in which wine may be distributed: directly to consumers, or through distributors to wine retailers. Consumers seeking to purchase directly would encounter the marks of both parties on the Internet and in national publications that review wine. "[O]rdinary wine consumers and purchasers encountering these highly similar marks on identical products could easily infer, mistakenly, that the brands are related or affiliated, even if they originate from different regions."⁴⁶⁹ The Board observed that, even if the parties' wines were marketed in different parts of the country and did not appear on the same store shelves, "that would not suffice to allay the likelihood of confusion."⁴⁷⁰ "Thus, we find that even if there were a geographic division of territories, the parties would still have overlapping classes of customers, whose susceptibility to confusion, engendered by the marked similarity of the parties' marks on identical goods, would not be appreciably reduced."⁴⁷¹

Ruling that Applicant Stawski was not entitled to concurrent registration of his marks, the Board dissolved the concurrent use proceeding.

10. Procedural Issues

a. Pleading Abandonment

Lewis Silkin LLP v. Firebrand LLC

Respondent Firebrand LLC moved to dismiss this petition for cancellation of its registration for the mark FIREBRAND for a "newsletter dealing with brand and product development" and for "business consultation services," asserting that Petitioner Lewis Silkin LLP had failed to state a claim for abandonment under the *Iqbal/Twombly* standard. Petitioner Silkin alleged that "[o]n information and belief, Respondent is not using Respondent's Mark on or in connection with Respondent's Goods and Services with no intent to resume such use."⁴⁷² The Board found these allegations to be legally sufficient, and so it denied the respondent's motion.

⁴⁶⁸ *Id.* at 1053-54, citing *Viterra*, 101 U.S.P.Q.2d at 1908.

⁴⁶⁹ *Id.* at 1055. See *In re Aquitaine Wine USA LLC*, 126 U.S.P.Q.2d 1181, 1194 (T.T.A.B. 2018).

⁴⁷⁰ *Id.*

⁴⁷¹ *Id.* at 1055-56.

⁴⁷² *Lewis Silkin LLP v. Firebrand LLC*, 129 U.S.P.Q.2d 1015, 1016 (T.T.A.B. 2018).

The *Iqbal/Twombly* standard of notice pleading requires that the complaint “state a claim to relief that is plausible on its face.”⁴⁷³ “Threadbare recitals of the elements of a cause of action, supported by mere conclusory statements, do not suffice.”⁴⁷⁴

The CAFC has not applied the *Iqbal/Twombly* standard to an abandonment claim, but the TTAB has on three occasions considered the legal sufficiency of an abandonment claim under that standard. In those cases, the Board did not find that the standard “required more than the traditional pleading of nonuse plus intent not to resume.”⁴⁷⁵

Under Section 45 of the Lanham Act, a mark shall be deemed to be abandoned “[w]hen its use has been discontinued with intent not to resume such use.”⁴⁷⁶ The Board found Respondent Silkin’s allegation of “no intent to resume use” to be equivalent to the statutory language of “intent not to resume use” for an abandonment claim.⁴⁷⁷ In *Johnson & Johnson*, the Board found that a counterclaim “sufficiently pleaded a ground for partial cancellation by alleging abandonment of the mark as to particular goods through nonuse with no intent to resume use.”⁴⁷⁸

The Board concluded that Silkin’s allegations that the respondent was not using the mark and services, and had no intent to resume use, were legally sufficient “in the context of the Board’s narrow jurisdiction limited to trademark registrability.”⁴⁷⁹ The Board rejected the argument that the pleader must include additional allegations demonstrating how it will prove the allegations of nonuse plus intent.

We see no purpose to such detailed pleading requirements for an abandonment claim, besides unnecessarily complicating the pleadings. As noted above, there is no list of activities which always show trademark use, and thus there is no list of activities whose cessation would always show trademark nonuse. Actual intent not to resume use (as

⁴⁷³ *Ashcroft v. Iqbal*, 556 U.S. 662, 678 (2009) (quoting *Bell Atl. Corp. v. Twombly*, 550 U.S. 544, 570 (2007)) (the “*Iqbal/Twombly* standard”).

⁴⁷⁴ *Ashcroft v. Iqbal*, 556 U.S. at 678.

⁴⁷⁵ *Lewis Silkin*, 129 U.S.P.Q.2d at 1017. See *Dragon Bleu (SARL) v. VENM, LLC*, 112 U.S.P.Q.2d 1925, 1931 (T.T.A.B. 2014); *SaddleSprings Inc. v. Mad Croc Brands Inc.*, 104 U.S.P.Q.2d 1948, 1950 (T.T.A.B. 2012); and *Johnson & Johnson v. Obschestvo s Ogranitchennoy*, 104 U.S.P.Q.2d 2037 (T.T.A.B. 2012).

⁴⁷⁶ 15 U.S.C. § 1127(1).

⁴⁷⁷ *Lewis Silkin*, 129 U.S.P.Q.2d at 1018-19. See *Cerveceria Centroamericana S.A. v. Cerveceria India Inc.*, 892 F.2d 1021, 13 U.S.P.Q.2d 1307, 1312 (Fed. Cir. 1989) (“a registrant may rebut a prima facie case either by disproving the underlying fact from which the presumption arises, i.e., two consecutive years of nonuse, or the presumed fact itself, i.e., no intent to resume use.”).

⁴⁷⁸ 104 U.S.P.Q.2d at 2039.

⁴⁷⁹ *Lewis Silkin*, 129 U.S.P.Q.2d at 1020.

opposed to the statutory period of nonuse which gives rise to the presumption of intent not to resume use) does not exist in a vacuum, but also must relate to the use in commerce of the mark. The Board is reluctant to see pleadings devolve into wrangling over whether specific factual allegations offered to demonstrate nonuse and intent not to resume use are sufficient to support the abandonment claim. These matters addressing what activities constitute use in commerce under the Trademark Act are best, and traditionally, left to trial.⁴⁸⁰

The Board noted that there has been an increase in parties arguing that “every pleading must demonstrate that the party undertook a reasonable inquiry or investigation before filing its pleading.”⁴⁸¹ The Board “strongly” disagreed that this is a pleading requirement.⁴⁸²

FRCP 8(a)(2) and (e) state that a pleading must include “a short and plain statement of the claim showing that the pleader is entitled to relief” and must be “construed so as to do justice.” Whether the plaintiff will be able to prove its abandonment claim is “irrelevant to assessment of the legal sufficiency of the complaint.”⁴⁸³

Finding the petition for cancellation to be legally sufficient, the Board denied the respondent’s FRCP 12(b)(6) motion to dismiss.

b. Timeliness Issues Under 2017 Rule Changes

Asustek Computer Inc. v.

Chengdu Westhouse Interactive Entertainment Co.

In the latest of several precedential decisions dealing with timing issues under the January 2017 TTAB rule changes, the Board rejected Opposer Asustek’s request for reconsideration of an order denying as untimely its motion to compel discovery responses. The motion to compel was filed on the day of the deadline for the opposer’s pre-trial disclosures, and not before that day, as required by the applicable rule.⁴⁸⁴

Under Trademark Rule 2.120(f)(1), as amended on January 14, 2017, “[a] motion to compel discovery must be filed before the day of the deadline for pretrial disclosures for the first testimony period as originally set or as reset.”⁴⁸⁵ The deadline for Asustek’s pretrial

⁴⁸⁰ *Id.*

⁴⁸¹ *Id.*

⁴⁸² *Id.*

⁴⁸³ *Id.* at 1020-21, citing *Guess? IP Holder LP v. Knowlux LLC*, 116 U.S.P.Q.2d 2018, 2019 (T.T.A.B. 2015).

⁴⁸⁴ *Asustek Comput. Inc. v. Chengdu Westhouse Interactive Entm’t Co.*, 128 U.S.P.Q.2d 1470 (T.T.A.B. 2018).

⁴⁸⁵ 37 C.F.R. § 2.120(f)(1).

disclosures fell on Monday, September 25, 2017; therefore, under the rule, the last date to file a motion was “before the day of” that date—i.e., by Sunday, September 24.

Asustek filed its motion to compel on Monday, September 25, 2017. It maintained that it made a “reasonable interpretation” that Rule 2.196⁴⁸⁶—which allows parties until the next business day to take action if a fixed deadline falls on a Saturday, Sunday, or Federal holiday—applied to its situation.⁴⁸⁷ The Board, however, pointed out that Rule 2.196 does not apply to Rule 2.120(f)(1), because the latter rule does not fix a particular day by which a motion to compel must be filed, but instead requires that the motion be filed before the day another event (e.g., pretrial disclosures) occurs.⁴⁸⁸

The phrase “before the day of the deadline for pretrial disclosures” in Rule 2.120(f)(1) “means that the motion to compel must be filed sometime prior to the day pretrial disclosures are due.”⁴⁸⁹

The inapplicability of Rule 2.196 remains similar to TTAB practice under the pre-amendment rule. Under former Trademark Rule 2.120(e)(1), a motion to compel had to be filed prior to the commencement of the first testimony period.⁴⁹⁰ “Prior to” meant any time before the opening day of trial, i.e., before the first day of the plaintiff’s testimony period.⁴⁹¹

In short, Trademark Rule 2.120(f)(1) requires that a motion to compel be filed before the day of the deadline for plaintiff to file and serve pretrial disclosures. As Opposer’s motion to compel was filed and served on September 25, 2017, the due date for Opposer’s pretrial disclosures, it was not served

⁴⁸⁶ 37 C.F.R. § 2.196 states:

Whenever periods of time are specified in this part in days, calendar days are intended. When the day, or the last day fixed by statute or by regulation under this part for taking any action or paying any fee in the Office falls on a Saturday, Sunday, or Federal holiday within the District of Columbia, the action may be taken, or the fee paid, on the next succeeding day that is not a Saturday, Sunday, or a Federal holiday.

⁴⁸⁷ *Asustek Comput.*, 128 U.S.P.Q.2d at 1470.

⁴⁸⁸ *Id. Cf. Studi Moline Dissey, S.L. v. BioUrn Inc.*, 123 U.S.P.Q.2d 1268 (T.T.A.B. 2017) (holding that Rule 2.196 does not apply to the requirement that discovery be served early enough so responses will be due no later than close of discovery).

⁴⁸⁹ *Id.* at 1471. See MISCELLANEOUS CHANGES TO TRADEMARK TRIAL AND APPEAL BOARD RULES; CLARIFICATION, 82 Fed. Reg. 33804, 33804 (July 21, 2017) (*Clarification*).

⁴⁹⁰ *Id. Cf. KID-Systeme GmbH v. Türk Hava Yollari Teknik Anonim Sirketi*, 125 U.S.P.Q.2d 1415, 1416 (T.T.A.B. 2018) (pre-amendment rule for filing summary judgment required filing “prior to commencement” of first testimony period).

⁴⁹¹ *Id.*, n.2. See *Blansett Pharmacal Co. v. Carmrick Labs., Inc.*, 25 U.S.P.Q.2d 1473, 1476 (T.T.A.B. 1992).

“before” the date set for pretrial disclosures and is untimely.⁴⁹²

Opposer Asustek argued that the Board should apply the flexible approach for cases that arose during transition to the Board’s new rules, as in the *KID-Systeme* case, where the Board allowed consideration of an otherwise untimely motion for summary judgment filed on the deadline for pretrial disclosures, rather than before that date. The Board pointed out, however, that *KID-Systeme* involved a motion that was filed prior to the Board’s July 21, 2017, *Clarification* of the rule. Here, Asustek’s motion to compel was filed two months after *KID-Systeme* was decided and after the *Clarification* was issued.

To the extent flexibility was warranted in *KID-Systeme* because of any perceived ambiguity in the Rule as originally amended, both the decision in that case and the subsequent *Clarification* resolved that ambiguity, putting Opposer and other Board litigants on notice of the proper application of the Rule. When Opposer filed its motion, the amended Rule had been in place more than eight months, and explicitly required filing before the day of the deadline for pretrial disclosures.⁴⁹³

c. Timeliness of Testimony Declaration Signature

Robinson v. Hot Grabba Leaf, LLC

Petitioner Michael A. Robinson’s petition for cancellation backfired when the Board granted the respondent’s counterclaim for cancellation of Robinson’s registrations for the mark GRABBA LEAF, in standard character and design form, for cigar wraps. Robinson alleged that the respondent’s mark, HOT GRABBA NATURAL TOBACCO LEAF for leaf tobacco, would likely cause confusion with his registered marks. The Board, however, found his marks to be merely descriptive, and so it granted the counterclaim and dismissed Robinson’s petition for cancellation.⁴⁹⁴

During his testimony period, Robinson submitted his own declaration that had been filed in the applications that matured into his two registrations. He asserted that Rule 2.123(a)(1) permits testimony to be submitted in affidavit or declaration form. The respondent argued that these declarations were inadmissible as untimely because Rule 2.121(a)(1) states that “[no] testimony shall be taken or evidence presented except during the times assigned,

⁴⁹² *Id.*

⁴⁹³ *Id.*

⁴⁹⁴ *Robinson v. Hot Grabba Leaf, LLC*, 2019 U.S.P.Q.2d 149089 (T.T.A.B. 2019). The mere descriptiveness issue is discussed in Part II.B.2, above.

unless by stipulation of the parties approved by the Board, or upon motion granted by the Board, or by order of the Board.”⁴⁹⁵

The Board agreed with the respondent: “Absent a stipulation or Board order, a testimony affidavit or declaration must be taken—that is, executed—during the assigned testimony period, as required by Rule 2.121(a).”⁴⁹⁶

The Board pointed out that this problem may be avoided by submitting such a declaration “under a timely taken affidavit or declaration attesting to the continued accuracy of the information residing therein.”⁴⁹⁷ The Board also noted that, had the declaration been considered, it would not have changed the outcome of the case.

d. Declaration Signed Abroad

M/S R.M. Dhariwal (HUF) 100% EOU v. Zarda King Ltd. et al.

In this rare opposition proceeding alleging lack of consent to register under Section 2(c) of the Lanham Act, the Board granted Applicant Global’s motion to strike an unsworn declaration submitted by the opposer that was made under the penalty of perjury but did not refer to United States law.⁴⁹⁸

Trademark Rule 2.123(a)(1)⁴⁹⁹ provides that testimony may be submitted in the form of a sworn affidavit, or a declaration under Trademark Rule 2.20.⁵⁰⁰ The latter rule states that, in lieu of a sworn affidavit, an unsworn declaration may use language referencing 18 U.S.C. § 1001. In either case, a declarant is subject to United States perjury laws if willful or knowing false statements are made.⁵⁰¹

⁴⁹⁵ 37 C.F.R. § 2.121(a)(1).

⁴⁹⁶ *Robinson*, 2019 U.S.P.Q.2d 149089 at *8.

⁴⁹⁷ *Id.* at *11, n. 23.

⁴⁹⁸ *M/S R.M. Dhariwal (HUF) 100% EOU v. Zarda King Ltd. et al.*, 2019 U.S.P.Q.2d 149090 (T.T.A.B. 2019). The Section 2(c) issue is discussed in Part II.B.1, above.

⁴⁹⁹ 37 C.F.R. § 2.123(a)(1), states, in pertinent part: “The testimony of witnesses in inter partes cases may be submitted in the form of an affidavit or a declaration pursuant to § 2.20”

⁵⁰⁰ 37 C.F.R. § 2.20, states: “Instead of an oath, affidavit, or sworn statement, the language of 28 U.S.C. 1746, or the following declaration language, may be used:

The signatory being warned that willful false statements and the like are punishable by fine or imprisonment, or both, under 18 U.S.C. 1001, and that such willful false statements and the like may jeopardize the validity of the application or submission or any registration resulting therefrom, declares that all statements made of his/her own knowledge are true and all statements made on information and belief are believed to be true.”

⁵⁰¹ *Dhariwal*, 2019 U.S.P.Q.2d 49090 at *6. See *In re Dermahose Inc.*, 82 U.S.P.Q.2d 1793, 1797 (T.T.A.B. 2007) (“the common feature of oaths, sworn statements, unsworn declarations under penalty of perjury, and declarations under Rule 2.20 is that the

When the declaration is signed in the United States, the laws of the United States apply automatically.⁵⁰² No specific reference to United States Law is required.⁵⁰³ However, if the declaration is signed outside the country, the declarant must state his or her intention to be bound by United States law.⁵⁰⁴ As observed in *Jack v. Trans World Airlines*:

When a person executes a document outside the United States, a recitation that it is made under penalty of perjury without reference to which country's perjury laws will be applied provides no assurance of truthfulness because the penalty of perjury may be non-existent or trivial in the place where the person signed the document.⁵⁰⁵

Here, the declaration in question, which was executed in Pune, India, did not include the necessary language and reference to 18 U.S.C. § 1001. Nor did it satisfy the requirements of 28 U.S.C. § 1746. That statutory provision, entitled "Unsworn declarations under penalty of perjury," states that an unsworn declaration executed without the United States must be "substantially in the following form":

I declare (or certify, verify, or state) under penalty of perjury under the laws of the United States of America that the foregoing is true and correct. Executed on (date). (Signature).

The challenged declaration did not substantially comply with 28 U.S.C. § 1746 due to the absence of the wording "under the laws of the United States" or its substantial equivalent.

And so, the Board refused to accept the unsworn declaration.

11. Discovery and Motion Practice

a. Counting Interrogatories

One Jeanswear Group Inc. v. YogaGlo, Inc.

The question of how to count interrogatories is faced often by TTAB practitioners but seldom by the Board. Here, the Board provided some helpful guidance on the issue. It granted Applicant YogaGlo's motion to compel responses to its interrogatories, overruling the opposer's objection that the number of

person making the statement is subjecting himself or herself to criminal penalties for making statements that the person knows are not true.").

⁵⁰² *Id.* at *6.

⁵⁰³ *Id.* at *7, n. 12.

⁵⁰⁴ *Id.* at *6.

⁵⁰⁵ 854 F. Supp. 654, 658 n.3 (N.D. Cal. 1994).

interrogatories exceeded Rule 2.120(d)'s limit of 75, including subparts.⁵⁰⁶

Applicant YogaGlo served 17 numbered interrogatories, in response to which Opposer One Jeanswear served a general objection that the number of interrogatories exceeded the limit.⁵⁰⁷ One Jeanswear contended that interrogatories 1–4 each inquired as to the “29 separate products” identified in the pleaded registrations, and each of those four interrogatories contained several subparts.⁵⁰⁸

The Board pointed out that it is not bound by a party's numbering or designation system.⁵⁰⁹ Instead, the Board will look at the substance of each interrogatory to see:

[W]hether it actually asks multiple distinct questions (e.g., sales figures and advertising figures), in which case each question is counted as a separate interrogatory, or whether it asks a single question, or all relevant facts and circumstances concerning a single issue, applicable to all pleaded marks or all asserted goods and services (such as, sales figures for each of a party's marks for multiple years), in which case it is counted as a single interrogatory.⁵¹⁰

The interrogatory count is not driven by the number of goods and services named in the involved applications or registrations.⁵¹¹ “Rather . . . the Board looks to the text of the interrogatories and counts the substance of each question as a separate interrogatory.”⁵¹²

The Board concluded that YogaGlo's interrogatories 1–4 “arguably comprise at most 9 subparts.”⁵¹³ Adding the remaining interrogatories (which, according to One Jeanswear, comprised 30 subparts), the total fell well within the 75-interrogatory limit.

⁵⁰⁶ *One Jeanswear Group Inc. v. YogaGlo, Inc.*, 127 U.S.P.Q.2d 1793 (T.T.A.B. 2018).

⁵⁰⁷ Trademark Rule 2.120(d), 37 C.F.R. § 2.120(d), provides, in pertinent part: “The total number of written interrogatories which a party may serve upon another party pursuant to Rule 33 of the Federal Rules of Civil Procedure, in a proceeding, shall not exceed seventy-five”

⁵⁰⁸ *One Jeanswear*, 127 U.S.P.Q.2d at 1796.

⁵⁰⁹ *Id.* See, e.g., *Kellogg Co. v. Nugget Distrib. Coop. of Am. Inc.*, 16 U.S.P.Q.2d 1468, 1469 (T.T.A.B. 1990). See also TBMP § 405.03(d) and cases cited therein.

⁵¹⁰ *Id.*, citing *Jan Bell Mktg., Inc. v. Centennial Jewelers, Inc.*, 19 U.S.P.Q.2d 1636, 1637 (T.T.A.B. 1990). See also Notice of Final Rulemaking, 54 Fed. Reg. 34886, 34893 (August 22, 1989).

⁵¹¹ *Id.* Thus, the Trademark Rules do not provide for additional interrogatories when more than one mark is pleaded or attacked, whether in a single or a consolidated proceeding, “because the propounding party may simply request that each interrogatory be answered with respect to each involved mark of the responding party, and the interrogatories will be counted the same as if they pertain to only one mark.” *Id.*

⁵¹² *Id.* at 1796-97.

⁵¹³ *Id.* at 1797.

And so, the Board granted the motion to compel and ordered One Jeanswear to serve its responses within thirty days.

b. Motion to Compel Proper Responses

*Hewlett Packard Enterprise Development LP v.
Arroware Industries, Inc.*

In olden days, one could think of a TTAB inter partes proceeding as a lower cost, less complicated alternative to filing a trademark infringement action, but not anymore. In this precedential order, the Board raked Respondent Arroware over the coals for failing to properly and fully respond to Petitioner Hewlett-Packard’s (“HP”) discovery demands. In line with its seemingly open-door policy on discovery, the Board tossed out many of Arroware’s objections to HP’s interrogatories and document requests and required that Arroware provide a (typically useless) attorney-client privilege log.⁵¹⁴

HP sought cancellation of a registration for the mark MY APOLLO for peer-to-peer software for sharing data and files, claiming abandonment. Dissatisfied with Arroware’s discovery responses, HP moved to compel.

Respondent Arroware objected to the number of interrogatories and document requests as excessive (i.e., more than seventy-five, including subparts). However, rather than serving a general objection under Rule 2.120(d),⁵¹⁵ Arroware made the mistake of serving objections and responses. It then asserted that it should not be required to supplement its responses because it “responded to a proper number.”⁵¹⁶ The Board, however, ruled that Arroware had waived its right to object on this numerical ground.

HP also argued that Arroware’s objections were mere “boilerplate” and did not explain how HP’s discovery requests were defective.⁵¹⁷ The Board observed that an objecting party “may not rely on conclusory statements” such as “overly broad, unduly burdensome, vague or ambiguous, or not proportional to the need of the case.”⁵¹⁸ The party must “detail with specificity the reasons for

⁵¹⁴ Hewlett Packard Enter. Dev. LP v. Arroware Indus., Inc., 2019 U.S.P.Q.2d 158663 (T.T.A.B. 2019).

⁵¹⁵ Trademark Rule 2.120(d), 37 C.F.R. § 2.120(d) provides, in pertinent part:

If a party upon which interrogatories have been served believes that the number of interrogatories exceeds the limitation specified in this paragraph (d), and is not willing to waive this basis for objection, the party shall, within the time for (and instead of) serving answers and specific objections to the interrogatories, serve a general objection on the ground of their excessive number.

⁵¹⁶ Hewlett Packard, 2019 U.S.P.Q.2d 158663 at *5.

⁵¹⁷ *Id.* at *7.

⁵¹⁸ *Id.* at *8.

its objections.”⁵¹⁹ Also, a responding party must state “clearly and affirmatively whether it has searched for and identified, but withheld, any documents responsive to any document request based on the objections it lodged in response to any of [the other party’s] document requests.”⁵²⁰ The Board therefore overruled Arroware’s objections.

Arroware managed to win one battle: the Board, noting that neither Fed. R. Civ. P. 36 nor the Board’s rules require a party to explain the basis for an admission or denial, deemed “impermissible” HP’s use of a “blanket interrogatory or document request” that seeks documents or information forming the basis of Arroware’s responses to requests for admission.⁵²¹ However, somewhat paradoxically, the Board okayed without explanation a blanket document request calling for all documents pertaining to Arroware’s interrogatory responses.⁵²²

Next, the Board considered Arroware’s invocation of Fed. R. Civ. P. 33(d)⁵²³ in relying on its business records in response to some of HP’s interrogatories, rather than providing narrative responses. The Board concluded that Arroware had failed to meet the applicable requirements for invoking this rule. Arroware (1) failed to specify why providing written responses would impose a significant burden and (2) failed to specify in sufficient detail where the answers to the interrogatories could be ascertained. The fact that HP’s document requests called for the same documents was deemed irrelevant. And so, the Board ordered Arroware to provide

⁵¹⁹ *Id.* See *Medtronic, Inc. v. Pacesetter Sys., Inc.*, 222 U.S.P.Q. 80, 83 (T.T.A.B. 1984) (“[I]t is incumbent upon a party who has been served with interrogatories to respond by articulating his objections (with particularity) to those interrogatories which he believes to be objectionable, and by providing information sought in those interrogatories which he believes to be proper.”); see also Fed. R. Civ. P. 33(b)(4) (“The grounds for objecting to an interrogatory must be stated with specificity.”) and Fed. R. Civ. P. 34(b)(2)(B) (“For each item or category, the response must . . . state with specificity the grounds for objecting to the request, including the reasons.”).

⁵²⁰ *Id.* at *8-9.

⁵²¹ *Id.* at *14.

⁵²² Although it is not crystal clear, it appears that an interrogatory or document request seeking the basis for a single admission or denial may be allowed; i.e., only the “blanket” version is disallowed.

⁵²³ Fed. R. Civ. P. 33(d), Option to Produce Business Records, states:

If the answer to an interrogatory may be determined by examining, auditing, compiling, abstracting, or summarizing a party’s business records (including electronically stored information), and if the burden of deriving or ascertaining the answer will be substantially the same for either party, the responding party may answer by:

- (1) specifying the records that must be reviewed, in sufficient detail to enable the interrogating party to locate and identify them as readily as the responding party could; and
- (2) giving the interrogating party a reasonable opportunity to examine and audit the records and to make copies, compilations, abstracts, or summaries.

“sworn, complete, and narrative responses” to these interrogatories.⁵²⁴

Finally, HP demanded that Arroware provide supplemental responses to its document requests that meet the “full scope of the requests.”⁵²⁵ Arroware’s responses stated that it would produce documents located after a reasonable search. Not good enough, said the Board. “[A] party must state whether or not it has responsive documents in its possession, custody or control and, if it does, state that the documents will be produced by a specified date or they are being withheld, based on a claim of privilege or a specified objection.”⁵²⁶

The Board ordered Arroware to “fully complete its search and production” and to fully meet the scope of the document requests.⁵²⁷ It further ordered Arroware to provide a privilege log. Arroware was not required, however, to identify all U.S. customers for the preceding three years, as HP demanded. Instead, the Board ordered Arroware to identify two newly registered U.S. users per year.⁵²⁸

The Board then set various deadlines for compliance with its order, and reset the remaining dates for discovery, briefing, and trial.

c. Designations Under the Standard Protective Order

U.S. Polo Ass’n v. David McLane Enterprises, Inc.

The Board seldom rules on protective order issues, at least in precedential decisions, but here it considered Petitioner United States Polo Association’s (“USPA”) motion challenging Respondent McLane Enterprises’ confidentiality designations as applied to certain documents and interrogatory responses pursuant to the Board’s Standard Protective Order. The Board granted petitioner’s

⁵²⁴ *Hewlett Packard*, 2019 U.S.P.Q.2d 158663 at *18.

⁵²⁵ *Id.* at *19.

⁵²⁶ *Id.* at *20. See Fed. R. Civ. P. 34(b)(2)(B)-(C):

(B) *Responding to Each Item.* For each item or category, the response must either state that inspection and related activities will be permitted as requested or state with specificity the grounds for objecting to the request, including the reasons. The responding party may state that it will produce copies of documents or of electronically stored information instead of permitting inspection. The production must then be completed no later than the time for inspection specified in the request or another reasonable time specified in the response.

(C) *Objections.* An objection must state whether any responsive materials are being withheld on the basis of that objection. An objection to part of a request must specify the part and permit inspection of the rest.

⁵²⁷ *Id.* at *21.

⁵²⁸ *Id.* at *22. One might ask how identifying customers is a proper response to a request for documents.

motion in large part, requiring re-designation of the responses and some of the documents.⁵²⁹

The Board's Standard Protective Order ("SPO")⁵³⁰ provides for two tiers of protected information: (1) Confidential and (2) Confidential—For Attorneys' Eyes Only (trade secret/commercially sensitive) (hereafter "AEO"). The Board cited TBMP Section 412.01 for an explanation of the applicability of those two terms.⁵³¹ The SPO (at paragraph 1) itself describes generally the types of information that may qualify as AEO. Of course, the designations dictate the level of protection accorded: i.e., who may have access to the information and materials. Essentially, parties, including inside counsel, have access to "Confidential" information but not AEO information. In either case, the information is shielded from public view by the Board.

Respondent McLane bore the burden of demonstrating the appropriateness of its confidentiality designations.⁵³² Because the parties were unable to agree on a modification of the SPO (the respondent wanted to restrict access to "Confidential" information to a single in-house attorney), the Board was required to decide which of the two "default designations" applied to the documents and information in dispute.⁵³³

Interrogatory responses: The Board reviewed three of Respondent McLane's interrogatory responses, which three responses concerned the identification of agreements, gross revenue figures under the mark at issue, and the identity of persons who communicated with McLane regarding use of the mark. McLane had designated its responses as AEO, asserting that Petitioner USPA, a direct competitor, would gain an advantage in future business deals if armed with this information.

The Board, however, observed that the SPO states that information protected under the order may be used only in connection with the Board proceeding, and each party is obligated

⁵²⁹ U.S. Polo Ass'n v. David McLane Enter., Inc., 2019 U.S.P.Q.2d 108442 (T.T.A.B. 2019).

⁵³⁰ The Board's Standard Protective Order is available at the Board's homepage, www.uspto.gov/ttab. It is automatically imposed in all inter partes proceedings. Trademark Rule 2.116(g), 37 C.F.R. § 2.116(g).

⁵³¹ According to TBMP § 412.01(a), the designations "Confidential" or "AEO"

should be limited to information that the producing party or their counsel has determined, in good faith, contains, reflects, or reveals non-public, confidential, proprietary or commercial information that is not readily ascertainable through proper means by the public or the receiving party, to the extent that information either is the type of information that the party normally attempts to protect from disclosure or is subject to privacy protection under federal, state or local law.

The "AEO" designation should be limited to information that "can be used in the operation of a business or other enterprise and that is sufficiently valuable and secret to afford an actual or potential economic advantage over others." *Id.*

⁵³² See Standard Protective Order, para. 14; TBMP § 412.01(b).

⁵³³ *U.S. Polo Ass'n*, 2019 U.S.P.Q.2d at *7-8.

to maintain the confidentiality of the information and must exercise reasonable care in that regard.⁵³⁴ McLane failed to show that disclosure of the information to Petitioner USPA would cause any injury, “let alone a clearly defined serious injury,” to McLane’s business.⁵³⁵ Nor did McLane produce “any evidence” supporting its fear that USPA would violate the protective order by misusing the information provided.⁵³⁶

The Board did allow the “Confidential” designation for these responses, since revenues are “routinely” treated as confidential in Board proceedings and since individual third parties named in the responses presumably expected their identities to remain private.⁵³⁷

Document Production: The documents at issue, designated as AEO by Respondent McLane, fell into the following six categories:

- (1) Agreements with ESPN. These documents were more than ten years old, and therefore “stale.”⁵³⁸ The Board allowed them to be labeled “Confidential.” Documents reflecting negotiations qualified as AEO.
- (2) Financing and operating agreements. Although more than ten years old, these documents disclosed the shares of each of the respondent’s members and therefore are appropriately designated as AEO.
- (3) Sponsorship opportunities. All except one of these documents were appropriately designated as AEO, since they disclose the respondent’s marketing strategies. A single document, indicating what Respondent McLane would charge sponsors in 2008, must be redesignated as “Confidential.”
- (4) Daily planner entries and notes. The respondent failed to address these documents, but the Board allowed them to be designated as “Confidential,” since they include third-party personal information.
- (5) The respondent’s plans in 2017. Again, the respondent failed to address these documents. Two appeared to be publicly available announcements meriting no protection under the SPO. The remaining document included email correspondence and proposed business terms and merited the “Confidential” designation.
- (6) Invoices. Respondent McLane again failed to address these documents. The invoices related to charges for hosting and domain registration services and, because

⁵³⁴ *Id.* at *9.

⁵³⁵ *Id.* at *10.

⁵³⁶ *Id.* at *9.

⁵³⁷ *Id.* at *12-13.

⁵³⁸ *Id.* at *15.

they contain information regarding the cost of maintaining the respondent's website, they may be designated as "Confidential."

The Board ordered proceedings to resume in accordance with a new scheduling order.

d. Extending the Discovery Period

Trans-High Corp. v. JFC Tobacco Corp.

The Board granted Applicant JFC Tobacco's motion to extend discovery, filed on the last day of the discovery period, to allow it to receive responses to its late-filed written discovery requests and to respond to Opposer Trans-High's discovery demands. Trans-High argued that, since JFC missed the written discovery deadline, it must show "excusable neglect" in order to justify re-opening discovery, but the Board ruled that the lesser, "good cause" standard applied.⁵³⁹

Discovery in this proceeding was set to close on January 22, 2018. Trademark Rule 2.120(a)(3) requires that written discovery requests be served early enough in the discovery period so that responses will be due no later than the close of discovery.⁵⁴⁰ Therefore, the deadline for serving written discovery requests in this case was December 23, 2017.⁵⁴¹

Applicant JFC served written discovery on January 10, 2018, and Trans-High promptly pointed out that this discovery was untimely. JFC sought Trans-High's consent for an extension of time for written discovery and for the close of discovery, but Trans-High did not provide a definitive response. And so, on January 22, JFC filed a motion to extend the close of discovery by thirty days.

JFC explained that it is located in Puerto Rico and encountered some delays during the proceeding due to Hurricane Maria, which devastated the region in September 2017, making it difficult for counsel to reach JFC. JFC pointed out that it had not requested any other extensions of time and argued that it would be prejudiced if it did not receive responses to its discovery requests.

⁵³⁹ *Trans-High Corp. v. JFC Tobacco Corp.*, 127 U.S.P.Q.2d 1175 (T.T.A.B. 2018).

⁵⁴⁰ Trademark Rule 2.120(a)(3), 37 C.F.R. § 2.120(a)(3) provides, in pertinent part: "Interrogatories, requests for production of documents and things, and requests for admission must be served early enough in the discovery period, as originally set or as may have been reset by the Board, so that responses will be due no later than the close of discovery."

⁵⁴¹ Responses to written discovery served on December 23, 2017, would be due thirty days later—i.e., on or before January 22, 2018. Service of discovery requests must be made by email unless otherwise stipulated. See Trademark Rule 2.119(b), 37 C.F.R. § 2.119(b). Under Fed. R. Civ. P. 33(b)(2), 34(b)(2)(A), and 36(a)(3), responses to interrogatories, production requests, and admission requests, respectively, are due thirty days after service.

Trans-High contended that JFC's motion was "in fact"⁵⁴² a motion to reopen its time to respond to written discovery and therefore the Fed. R. Civ. P. 6(b)(1)(B) standard of excusable neglect applied.⁵⁴³ It maintained that JFC failed to meet that standard, or even the lower "good cause" standard of Fed. R. Civ. P. 6(b)(1)(B) that applies to request for extensions of time filed *before* the expiration of the relevant deadline.

The Board observed that, under Trademark Rule 2.120(a)(2)(iv),⁵⁴⁴ it may grant limited extensions of the discovery period. Under Fed. R. Civ. P. 6(b)(1)(A), the appropriate standard for allowing an extension of a specific time period prior to its expiration is "good cause." So, in that regard, JFC's request was timely.

The Board was not persuaded by Trans-High's argument that the higher "excusable neglect" standard applied. Under the amended Trademark Rule 2.120(a)(3), effective January 14, 2017, "discovery must be served early enough in the discovery period that responses will be provided and all discovery will be complete by the close of discovery."⁵⁴⁵ The Notice of Final Rulemaking stated that the amendment to Rule 2.120(a)(3) with regarding to the timeliness of written discovery "has no impact on current Board practice concerning the ability of parties to seek extensions of the discovery period."⁵⁴⁶

While the Board encourages early service of discovery instead of reliance upon motions to extend the discovery period, a party wishing to serve discovery requests at a point in the discovery period when the last day for responding to the requests would fall after the close of discovery may seek an extension of the discovery period when appropriate and if it can establish *good cause* for the extension. *Estudi Moline*

⁵⁴² *Trans-High Corp.*, 127 U.S.P.Q.2d at 1176.

⁵⁴³ Fed. R. Civ. P. 6(b)(1), made applicable to Board proceedings by Trademark Rule 2.116(a), 37 C.F.R. § 2.116(a), states:

In General. When an act may or must be done within a specified time, the court may, for good cause, extend the time:

(A) with or without motion or notice if the court acts, or if a request is made, before the original time or its extension expires; or

(B) on motion made after the time has expired if the party failed to act because of excusable neglect.

⁵⁴⁴ Trademark Rule 2.120(a)(2)(iv), 37 C.F.R. § 2.120(a)(2)(iv), provides, in pertinent part: "Limited extensions of the discovery period may be granted upon stipulation of the parties approved by the Board, or upon motion granted by the Board, or by order of the Board."

⁵⁴⁵ Miscellaneous Changes to Trademark Trial and Appeal Board Rules, 81 Fed. Reg. 69,950, 69,951 (October 7, 2016) (Notice of Final Rulemaking).

⁵⁴⁶ *Trans-High Corp.*, 127 U.S.P.Q.2d at 1176.

Dissey, S.L. v. BioUrn Inc., 123 U.S.P.Q.2d 1268, 1271 n.6 (T.T.A.B. 2017) (emphasis added).⁵⁴⁷

In sum, “where the close of discovery has not yet passed, the time for serving requests is effectively reset under the good cause standard and the excusable neglect standard is inapplicable.”⁵⁴⁸

The Board found no evidence of bad faith on JFC’s part. Due to the impact of the hurricane and the difficulty for JFC’s counsel to reach JFC over the holiday period in order to respond to Trans-High’s discovery requests, the Board concluded that JFC had demonstrated the requisite good cause for extending both the discovery period and the time for responding to Trans-High’s discovery demands. It also deemed timely JFC’s written discovery demands.

e. Re-opening the Testimony Period

Coffee Studio LLC v. Reign LLC

In this brew-ha-ha over the mark COFFEE STUDIO, Respondent Reign LLC moved for dismissal after Petitioner Coffee Studio failed to submit any evidence or testimony during its testimony period. Coffee Studio then moved (1) to strike Reign’s dismissal motion due to improper service and (2) to re-open its testimony period on the ground that its evidentiary failure was excusable. The Board granted both of Coffee Studio’s motions.⁵⁴⁹

Improper Service: Reign did not serve its motion for dismissal directly on Coffee Studio, but instead relied on the email notice automatically generated by ESTTA (the Board’s electronic filing system) that was sent to Coffee Studio’s counsel, with a link to the motion as it appears in TTABVUE. Reign argued that Coffee Studio thus received actual notice of the motion via the Board’s email, as evidenced by Coffee Studio’s filing a response to the motion.

The Board pointed out that Rule 2.119(a)⁵⁵⁰ requires that every submission filed in an inter partes proceeding, except for the

⁵⁴⁷ *Id.* at 1176-77.

⁵⁴⁸ *Id.* at 1177. The key factor under the excusable neglect standard is whether the delay was within the control of the movant. *See Pumpkin, Ltd. v. Seed Corps*, 43 U.S.P.Q.2d 1582, 1586 n.7 (T.T.A.B. 1997) and cases cited therein. *See also Luster Prods., Inc. v. Van Zandt*, 104 U.S.P.Q.2d 1877, 1878 (T.T.A.B 2012). JFC may have been able to meet that higher standard as well.

⁵⁴⁹ *Coffee Studio LLC v. Reign LLC*, 129 U.S.P.Q.2d 1480 (T.T.A.B. 2019).

⁵⁵⁰ Trademark Rule 2.119(a), 37 C.F.R. § 2.119(a), states:

Except for the notice of opposition or the petition to cancel, every submission filed in the Office in inter partes cases, including notices of appeal to the courts, must be served upon the other party or parties. Proof of such service must be made before the submission will be considered by the Office. A statement signed by the attorney or other authorized representative, attached to or appearing on the original submission when filed, clearly stating the date and manner in which service was made will be accepted as prima facie proof of service.

petition to cancel or a notice of opposition, must be served upon the other party together with a certificate of service. In other words, actual service is required and it must be effected via email, absent an agreement otherwise.⁵⁵¹ Respondent Reign did not comply with the rules, and so the Board granted Coffee Studio's motion to strike.⁵⁵²

Excusable Neglect: Because Petitioner Coffee Studio sought to re-open a time period that had passed, it was required to show "excusable neglect" under Fed. R. Civ. P. 6(b)(1)(B).⁵⁵³ The Supreme Court clarified the meaning and scope of "excusable neglect" in *Pioneer Investment Services Co. v. Brunswick Assocs. Ltd. Partnership*.⁵⁵⁴

[The determination is] at bottom an equitable one, taking account of all relevant circumstances surrounding the party's omission. These include . . . [1] the danger of prejudice to the [non-moving party], [2] the length of the delay and its potential impact on judicial proceedings, [3] the reason for the delay, including whether it was within the reasonable control of the movant, and [4] whether the movant acted in good faith.⁵⁵⁵

The third *Pioneer* factor—the reason for the delay and whether it was within the reasonable control of the movant—is generally considered the most important factor.⁵⁵⁶

As to the first *Pioneer* factor, there was no evidence of prejudice to Respondent Reign, such as the unavailability of witnesses. As to the fourth factor, there was no evidence of bad faith on the part of Coffee Studio.

With regard to the second factor—the length of the delay and its potential impact—the Board must consider "the total length of the delay, including the time for the Board to consider the pending motions."⁵⁵⁷ It found the delay caused by Coffee Studio's failure to offer testimony or evidence during its testimony period, and the

⁵⁵¹ See Trademark Rule 2.119(b), 37 C.F.R. § 2.119(b), which provides in pertinent part: "Service of submissions filed with the Board and any other papers served on a party not required to be filed with the Board, . . . must be made by email, unless otherwise stipulated"

⁵⁵² The Board noted that even if it accepted Reign's motion under its inherent authority, it would have denied the motion in light of petitioner's showing of excusable neglect.

⁵⁵³ Rule 6(b)(1)(B) states that the court "may, for good cause, extend the time . . . on motion made after the time has expired if the party failed to act because of excusable neglect."

⁵⁵⁴ 507 U.S. 380 (1993).

⁵⁵⁵ *Id.* at 395.

⁵⁵⁶ See *Pumpkin*, 43 U.S.P.Q.2d at 1587 n.7, and cases cited therein. See also *Luster Prods., Inc. v. Van Zandt*, 104 U.S.P.Q.2d 1877, 1878 (T.T.A.B. 2012).

⁵⁵⁷ *Coffee Studio*, 129 U.S.P.Q.2d at 1483. See *Pumpkin*, 43 U.S.P.Q.2d at 1588 (finding calculation of length of delay must include delay arising from time required for briefing and deciding motion to reopen).

parties' motions arising therefrom, to be "minimal."⁵⁵⁸ It noted that Coffee Studio submitted its proposed testimonial affidavits and notices of reliance when it moved to reopen its testimony period. "This factor weighs in Petitioner's favor as it is a relatively short period of time and Petitioner attempted to mitigate any delay."⁵⁵⁹

As to the critical third factor, counsel for Coffee Studio asserted that "she was hospitalized with a serious medical condition on April 2, 2018, was intermittently hospitalized requiring medical leave since then, and that in her absence only an inexperienced first-year associate was available to take over her duties in this case."⁵⁶⁰ Respondent Reign questioned why a medical condition in April had any effect on a June date for filing trial evidence, and why the associate did not seek suspension or an extension of time based on the medical emergency. The Board sided with Petitioner Coffee Studio, but provided little explanation: "We find, taking into account the totality of the circumstances of this specific case discussed in Petitioner's motion to reopen, that Petitioner's failure to take appropriate action prior to the close of its testimony period was not within Petitioner's reasonable control."⁵⁶¹

The Board observed that it expects that Coffee Studio's counsel "has made preparations for improved staff coverage in the event illness intrudes again, and does not expect any delay to remaining trial periods or briefing."⁵⁶²

Considering and balancing the four *Pioneer* factors, the Board found that Coffee Studio's failure to act in a timely fashion was the result of excusable neglect, and so the motion to reopen was granted.

***f. Cross-examination of Domestic Testimonial
Declarant or Affiant***

Andrusiek v. Cosmic Crusaders LLC

In this cancellation proceeding involving a registration for the mark CAPTAIN CANNABIS for comic books, the Board faced the question of whether a witness located in the United States, whose testimony was submitted by affidavit or declaration under

⁵⁵⁸ The delay amounted to about eight and one-half months, seven of which occurred after the motion papers were filed.

⁵⁵⁹ *Coffee Studio*, 129 U.S.P.Q.2d at 1483.

⁵⁶⁰ *Id.*

⁵⁶¹ *Id.*

⁵⁶² *Id.*

Rule 2.123(a)(1),⁵⁶³ may be cross-examined by written questions. No, said the Board, only by oral cross-examination.⁵⁶⁴

Petitioner Laverne J. Andrusiek moved for leave to take the cross-examination of two witnesses, both located in the United States, on written questions. She pointed to the expense and inconvenience of oral depositions because the witnesses were in Tampa, Florida, while she is located in Washington state.

In opposition to the motion, Respondent Cosmic Crusaders relied on Trademark Rules 2.123, and 2.124, neither of which provides for cross-examination by written questions. The Trademark Rules allow a party to “take” direct testimony by submitting an affidavit or declaration or by oral examination under Rule 2.123, or by written questions under Rule 2.124.⁵⁶⁵ As for cross-examination, the proper procedure differs depending on the location of the witness.

Where, as here, testimony is presented by affidavit or declaration, Trademark Rules 2.123(a)(1) and (a)(2) make clear that the methods of cross-examination permitted depend on where the witness is located. “[I]f such witness is within the jurisdiction of the United States,” any adverse party may “take . . . oral cross-examination of that witness . . .” . . . “[I]f such witness is outside the jurisdiction of the United States,” any adverse party may “conduct cross-examination by written questions as provided in § 2.124”⁵⁶⁶

The Board concluded that Trademark Rule 2.123(a)(1) “permits an affiant or declarant witness located in the United States to be cross-examined only by oral examination.”⁵⁶⁷

Addressing Andrusiek’s concern about expense, the Board noted that the Rules do not require that oral cross-examination be conducted in person. It may be conducted by telephone or other remote means either through stipulation or on motion for good cause.⁵⁶⁸ “[N]othing in the language of Rule 30 requires a showing of necessity, financial inability or other hardship to obtain an order to proceed via telephone, . . . leave to take telephonic depositions [is]

⁵⁶³ Trademark Rule 2.123(a)(1), 37 C.F.R. § 2.123(a)(1), provides in pertinent part: “The testimony of witnesses in inter partes cases may be submitted in the form of an affidavit or declaration pursuant to § 2.20 and in conformance with the Federal Rules of Evidence”

⁵⁶⁴ *Andrusiek v. Cosmic Crusaders LLC*, 2019 U.S.P.Q.2d 222984 (T.T.A.B. 2019).

⁵⁶⁵ If the witness is located abroad, the testimony may be taken either by affidavit or declaration or by written questions, unless the parties stipulate to oral examination or the Board grants a motion for good cause. *See* Trademark Rule 2.123(b).

⁵⁶⁶ *Andrusiek*, 2019 U.S.P.Q.2d 222984 at *4, quoting Trademark Rule 2.123(a)(1).

⁵⁶⁷ *Id.* at *5.

⁵⁶⁸ *See* Fed. R. Civ. P. 30(b)(4).

liberally granted in appropriate cases.”⁵⁶⁹ The Board construed Petitioner Andrusiek’s motion as an alternative request for leave to take oral cross-examination by telephone or other remote means. “Since it is Respondent who has insisted on oral cross-examination, the Board sees neither harm nor prejudice to Respondent in permitting Petitioner to conduct such cross-examination by remote means should Petitioner elect to do so.”⁵⁷⁰

Finally, the Board pointed out that Respondent Cosmic Crusaders will bear the expense of producing the witness, but Andrusiek must schedule and bear the expense of the court reporter.⁵⁷¹ Redirect or re-cross must be taken at the same time as the cross-examination.

***g. Cross-examination of a Foreign Testimony
Declarant or Affiant***

Empresa Cubana Del Tabaco v. General Cigar Co., Inc.

In this long-smoldering cancellation proceeding aimed at a registration for the mark COHIBA for cigars, the Board considered “the means available to cross-examine a declarant or affiant testimonial witness outside the jurisdiction of the United States.”⁵⁷² Respondent General Cigar filed a motion seeking (1) to take the oral cross-examination testimony of the petitioner’s two foreign (Cuban) trial witnesses or, alternatively, (2) to take their testimony during its (General Cigar’s) testimony period. The Board denied both motions.

Oral Cross-Examination of Foreign Witness: General Cigar acknowledged that cross-examination testimony of a witness outside the jurisdiction of the United States is to be taken by deposition on written questions.⁵⁷³ However, it pointed to Rule 2.123(a)(2),⁵⁷⁴ which provides that testimony may be taken orally upon Board order based on good cause, and it argued that the Board

⁵⁶⁹ *Hewlett-Packard Co. v. Healthcare Pers. Inc.*, 21 U.S.P.Q.2d 1552, 1553 (T.T.A.B. 1991).

⁵⁷⁰ *Andrusiek*, 2019 U.S.P.Q.2d 222984 at *6.

⁵⁷¹ *Id.* at *6-7. *See Barclays Capital Inc. v. Tiger Lily Ventures Ltd.*, 124 U.S.P.Q.2d 1160, 1166-67 (T.T.A.B. 2017); *Miscellaneous Changes to Trademark Trial and Appeal Board Rules*, 81 Fed. Reg. 69950, 69964 (Oct. 7, 2016) (Notice of Final Rulemaking).

⁵⁷² *Empresa Cubana Del Tabaco v. Gen. Cigar Co., Inc.*, 2019 U.S.P.Q.2d 227680 (T.T.A.B. 2019).

⁵⁷³ *See Trademark Rule 2.132(a)(1)*, 37 C.F.R. § 2.132(a)(1).

⁵⁷⁴ *Trademark Rule 2.123(a)(2)*, 37 C.F.R. § 2.123(a)(2), provides in pertinent part:

Testimony taken in a foreign country shall be taken: by deposition upon written questions as provided by § 2.124, unless the Board, upon motion for good cause, orders that the deposition be taken by oral examination, or the parties so stipulate; or by affidavit or declaration, subject to the right of any adverse party to elect to take and bear the expense of cross-examination by written questions of that witness.

can also order oral cross-examination of a foreign witness if good cause is shown.

The Board pointed out that Rule 2.123(a)(2) allows the offering party to choose the means of taking testimony in a foreign country: (1) by deposition upon written questions as provided by Trademark Rule 2.124; or (2) by affidavit or declaration, subject to the right of any adverse party to elect to take and bear the expense of cross-examination by written questions of that witness. Rule 2.123(a)(1) is to the same effect. Moreover, the “plain wording” of Rules 2.123(a)(1) and (a)(2) is reflected in Rule 2.123(e)(1), which provides for cross-examination by written question under Rule 2.124.⁵⁷⁵

These provisions are clear and unambiguous in their meaning and intent and there is no basis or cause to read into the rules a method for taking cross-examination of an affiant or declarant in a foreign country beyond that explicitly provided for in the Board’s rules. *Cf.* BBA Nonwovens Simpsonville, Inc. v. Superior Nonwovens, LLC, 303 F.3d 1332, 64 U.S.P.Q.2d 1257, 1262 (Fed. Cir. 2002) (“If a statute’s language is plain and unambiguous, and conveys a clear and definite meaning, there is no occasion for employing rules of statutory interpretation”) quoting *Ray Bell Constr. Co. v. Sch. Dist. of Greenville Cnty.*, 331 S.C. 19, 501 S.E.2d 725, 729 (1998).⁵⁷⁶

And so, the Board refused to order oral cross-examination of the Cuban witnesses.

Direct Oral Testimony of Petitioner’s Witnesses: As an alternative, General Cigar requested leave to take the oral direct testimony of the two Cuban witnesses during its own trial period, “with the direct examination to encompass cross-examination of the facts set forth in the Cuban Witness Declarations.”⁵⁷⁷ However, because General Cigar’s trial period had not yet begun, the Board denied the motion as premature.

In addition, the Board pointed out that, although the rules allow oral direct testimony of a foreign trial witness, upon motion for good cause, “there is no certain procedure for obtaining the trial testimony deposition of a nonparty who resides in a foreign country and is not willing to appear voluntarily, whether the deposition sought is intended to be taken orally or upon written questions.”⁵⁷⁸

⁵⁷⁵ Trademark Rule 2.123(e)(1), 37 C.F.R. § 2.123(e)(1), provides in pertinent part: “When testimony is proffered by affidavit or declaration, every adverse party will have the right to elect oral cross-examination of any witness within the jurisdiction of the United States. For examination of witnesses outside the jurisdiction of the United States, see § 2.124.”

⁵⁷⁶ *Empresa Cubana Del Tabaco*, 2019 U.S.P.Q.2d 227680 at *4-5.

⁵⁷⁷ *Id.* at *5.

⁵⁷⁸ *Id.* at *6, citing *Galaxy Metal Gear, Inc. v. Direct Access Tech., Inc.* 91 U.S.P.Q.2d 1859, 1862 (T.T.A.B. 2009).

Finally, the Board noted two hurdles that General Cigar may face even if it did obtain leave to take oral testimony in a foreign jurisdiction: it should determine whether the foreign country permits such a deposition, and under what procedure.⁵⁷⁹ Moreover, the deposition may not be taken on notice alone, and if the Cuban declarants are not willing to appear voluntarily, General Cigar must take steps to compel their attendance.⁵⁸⁰

h. Sanctions for Misconduct

SFM, LLC v. Corcamore, LLC

Apparently fed up with four years of misconduct by Respondent Corcamore, LLC, the Board granted Petitioner SFM's motion for judgment under Trademark Rule 2.120(h)(1)⁵⁸¹ and pursuant to the Board's inherent authority to sanction,⁵⁸² as a result of Corcamore's numerous discovery violations and repeated flouting of Board orders, rules, and procedures.⁵⁸³

SFM, LLC petitioned for cancellation of Corcamore's registration for the mark SPROUT for vending machine services, alleging priority and likelihood of confusion with its marks SPROUTS and SPROUTS FARMERS MARKET for retail grocery store services.

In 2015, after determining that Corcamore had filed an "inordinate number of motions (all of which have been denied) at a

⁵⁷⁹ *Id.* at n.12. TBMP § 404.04 states:

A party which wishes to take a deposition in a foreign country should first consult with local counsel in the foreign country, and/or with the Office of Legal Affairs, Department of State, in order to determine whether the taking of the deposition will be permitted by the foreign country, and, if so, what procedure must be followed.

⁵⁸⁰ *Id.* at n.12, citing TBMP § 703.01(f)(3), which states:

There is no certain procedure for obtaining, in a Board inter partes proceeding, the trial testimony deposition of a witness who resides in a foreign country, is an adverse party or a non-party (or an official or employee of an adverse party or non-party), and is not willing to appear voluntarily to testify. However, the deposing party may be able to obtain the testimony deposition of such a witness through the letter rogatory procedure or The Hague Convention letter of request procedure.

⁵⁸¹ Trademark Rule 2.120(h)(1), 37 C.F.R. § 2.120(h)(1) provides in pertinent part:

If a party fails to participate in the required discovery conference, or if a party fails to comply with an order of the Trademark Trial and Appeal Board relating to disclosure or discovery, including a protective order, the Board may make any appropriate order, including those provided in Rule 37(b)(2) of the Federal Rules of Civil Procedure, except that the Board will not hold any person in contempt or award expenses to any party.

⁵⁸² See *MHW Ltd. v. Simex, Aussenhandelsgesellschaft Savelsberg KG*, 59 U.S.P.Q.2d 1477, 1478 (T.T.A.B. 2000); *Carrini Inc. v. Carla Carini S.R.L.*, 57 U.S.P.Q.2d 1067, 1071 (T.T.A.B. 2000).

⁵⁸³ *SFM, LLC v. Corcamore, LLC*, 129 U.S.P.Q.2d 1072 (T.T.A.B. 2018).

very early stage in this proceeding,”⁵⁸⁴ the Board prohibited Corcamore from filing any additional unconsented motions without first obtaining Board permission. Nonetheless, Corcamore continued to file unnecessary or procedurally improper motions, causing the Board to issue another prohibition on unconsented motions without first obtaining its permission. The Board ordered that Corcamore, before filing another motion, must contact the Board’s interlocutory attorney to conduct a case conference with counsel for Petitioner SFM also present. Corcamore failed to comply with that order.

In the discovery arena, Corcamore filed an “eleventh-hour” motion for a protective order, seeking to defer the deposition of its Fed. R. Civ. P. 30(b)(6) witness until the Board had ruled on Corcamore’s untimely motion to compel.⁵⁸⁵ The Board denied the motion. The Board then granted Petitioner SFM’s motion to compel supplemental responses to certain document requests and interrogatories.

Corcamore refused to provide its Rule 30(b)(6) witness for deposition, failed to timely and fully provide supplemental discovery responses, and failed to include a “Bates number” on the documents it did produce, despite the Board’s order that it do so.

Respondent has refused to cooperate in the discovery process for over sixteen months. Respondent’s discovery violations are repeated, egregious and demonstrate Respondent’s intent to thwart Petitioner’s discovery of information and documents the Board has already determined are discoverable. There is no reason to assume that, given additional opportunities, Respondent will fulfill its obligations under the Federal and Trademark Rules and the Board’s orders. Accordingly, Petitioner’s motion for discovery sanctions in the form of judgment is granted under Trademark Rule 2.120(h).⁵⁸⁶

In addition, Corcamore violated two Board orders in numerous ways, as noted below. The Board concluded that Corcamore’s conduct, taken as a whole, warranted sanction in the form of judgment pursuant to the Board’s inherent authority to enter sanctions. “In assessing sanctions under our inherent authority, we consider: (1) bad faith conduct; (2) willful disobedience of Board orders; (3) length of delay or clear pattern of delay; (4) due warning that sanctions may be entered; (5) reasons for noncompliance; and (6) effectiveness of lesser or alternative sanctions.”⁵⁸⁷

⁵⁸⁴ *Id.* at 1073.

⁵⁸⁵ *Id.* at 1074.

⁵⁸⁶ *Id.* at 1078.

⁵⁸⁷ *Id.* See *Carrini*, 57 U.S.P.Q.2d at 1071-72.

Respondent's conduct has been particularly egregious. Respondent made good on its promise to impose a "procedural Rubicon" in this proceeding with Respondent's campaign of filing frivolous motions, by, inter alia, refusing to meet and confer with counsel for Petitioner regarding Respondent's discovery responses, hanging up on counsel for Petitioner during a meet and confer telephone conference on two separate occasions, outright refusing to "read or open" emails from Petitioner's counsel of record for years, and refusing to work with counsel for Petitioner to reschedule depositions of its Fed. R. Civ. P. 30(b)(6) and 30(b)(1) witnesses. In violation of Patent and Trademark Office Rule 11.402(a), counsel for Respondent also communicated directly with Petitioner about this case, without authorization to do so, knowing that Petitioner was represented by counsel.⁵⁸⁸

The Board found it "obvious from a review of the record that the respondent has been engaging for years in delaying tactics, including the willful disregard of Board orders, taxing Board resources and frustrating Petitioner's prosecution of this case."⁵⁸⁹

⁵⁸⁸ *Id.*

⁵⁸⁹ *Id.* at 1079.

**PART III. LITIGATION IN THE FEDERAL COURTS AND
STATE COURTS OF GENERAL JURISDICTION**

By Theodore H. Davis Jr.

A. Infringement, Unfair Competition, and Related Torts

1. Establishing Liability

a. Violations of Trademark and Service Mark Rights

i. Defining Claimed Marks

Under Section 45 of the Act, a trademark conceivably can consist of “any word, name, symbol, or device, or any combination thereof”; the same statute contains a substantively identical definition of “service mark.”⁵⁹⁰ These definitions are deliberately broad, and they led two plaintiffs to seek protection for what they described as “large-scale, immersive, light-based installations, and exhibitions.”⁵⁹¹ The plaintiffs offered the following representative examples of their installations and exhibitions in an appellate brief to the Eighth Circuit after a district court dismissed their claim to trade dress protection at the pleadings stage:⁵⁹²



In affirming, the appellate court held that:

[The plaintiffs’] installation [allegedly copied by the defendants] is not a “mark” that the Lanham Act [might] protect. Rather, the installation is the product itself. Because the light installation is a product, not a mark, and because copyright, not trademark, protects artistic and creative ideas

⁵⁹⁰ 15 U.S.C. § 1127 (2018).

⁵⁹¹ See *Munro v. Lucy Activewear, Inc.*, 899 F.3d 585, 588 (8th Cir. 2018), *cert. denied*, 139 S. Ct. 941 (2019).

⁵⁹² Brief of Plaintiffs-Appellants at 3, *Munro v. Lucy Activewear, Inc.*, 899 F.3d 585 (8th Cir. 2018) (No. 16-4483).

and concepts, [the plaintiffs'] claim does not properly fall under the Lanham Act.⁵⁹³

Another motion to dismiss similarly succeeded in a lawsuit brought by the creators of decorative wood products, which they alleged constituted protectable trade dress.⁵⁹⁴ The “hundreds” of designs to which the plaintiffs claimed protection included the following representative examples:⁵⁹⁵



Not surprisingly, the court concluded as a threshold matter that “Plaintiffs’ products, when taken as a whole, present no consistent look,”⁵⁹⁶ and that ultimately proved fatal to the sufficiency of their complaint:

Plaintiffs seek to protect the trade dress covering a line of products that share little in common. Plaintiffs’ broadly claimed trade dress includes “the design” of the products. But as a whole, the products differ vastly—they are made of different materials, are different shapes, serve different purposes, and have different designs. . . . For the Court to grant such broad protection would be simply improper.⁵⁹⁷

The court therefore granted the defendants’ motion to dismiss the plaintiffs’ complaint (albeit with leave to amend), further observing that “the claim for protection of trade dress of ‘the design,’ of such a

⁵⁹³ *Munro*, 899 F.3d at 590 (citation omitted).

In contrast, the same opinion confirmed that the verbal titles of the plaintiffs’ works *could* achieve status as marks for the plaintiffs’ installations. In dismissing the entirety of the plaintiffs’ complaint and refusing them leave to replead, the district court improbably concluded that, as the Eighth Circuit put it, “the names merely identified [the lead plaintiff] as the artist or source of the creative idea.” *Id.* at 592. The appellate court reached the contrary conclusion, namely, that:

[T]he names . . . are serving a source-identifying function for the installations, distinguishing them as unique products made by [the plaintiffs]. Because [the plaintiff] produces these installations, he is the “origin of goods” or “source” that the names identify, which entitles him to bring an action under the Lanham Act.

Id.

⁵⁹⁴ See *Crafty Prods., Inc. v. Michaels Cos.*, 389 F. Supp. 3d 876, 881 (S.D. Cal. 2019).

⁵⁹⁵ *Id.* at 881 & n.4; *id.* at 882 n.6.

⁵⁹⁶ *Id.* at 882.

⁵⁹⁷ *Id.* at 882-83 (citation omitted).

wide variety of products does not give a competitor sufficient notice of what is to be protected.”⁵⁹⁸

In a less extensive opinion, a different court held that the plaintiff before it failed to define with sufficient clarity the trade dress in which the plaintiff asserted rights.⁵⁹⁹ The plaintiff’s amended complaint referenced “the ornamental appearance of carbon fiber style graphics applied in an arbitrary fashion to a portion of [the automotive accessories offered by the plaintiff],”⁶⁰⁰ but the court faulted that formulation on multiple levels. To begin with, it accused the plaintiff of “merely identif[y]ing] one (1) feature utilized on one (1) of its products, *i.e.*, [an air horn], in order to ‘essentially corner the market’ on the idea of using ‘carbon fiber style graphics’ on automotive accessories.”⁶⁰¹ “Federal trademark law does not protect such an idea, concept or ‘generalized type of appearance,’”⁶⁰² the court concluded; consequently, “the amended complaint fails to state a plausible claim for trademark or trade dress infringement under Section 43(a)(1)(A) of the Lanham Act.”⁶⁰³

In contrast, other opinions rejected defendants’ claims that plaintiffs had failed to define their marks with the required degree of specificity.⁶⁰⁴ For example, a Massachusetts federal district court dismissed the argument that a plaintiff claiming trade dress protection in the appearance of its website had failed to define the protectable elements of the site with specificity.⁶⁰⁵ Weighing a defense motion for summary judgment, the court noted references in the plaintiff’s complaint to the following elements of the site: (1) “an orange and light blue color schematic” with “[t]he trim of the website and the ‘buttons’ . . . in orange and . . . a light blue strip in the center of the website”; (2) an announcement reading “[t]ranslate your website” appearing “[i]n the left-hand side of the light blue strip”; (3) links labeled “HOW IT WORKS” and “PRICING” on the site’s upper right-hand corner; and (4) “a promotional video that customers could watch directly on the website by clicking a ‘play’ button” using “a white, lower-case letter, sans-serif font to display the [plaintiff’s word] mark, along with a speech bubble adjacent to

⁵⁹⁸ *Id.* at 833.

⁵⁹⁹ *See* Wolo Mfg. Corp. v. ABC Corp., 349 F. Supp. 3d 176 (E.D.N.Y. 2018).

⁶⁰⁰ *Id.* at 203-05.

⁶⁰¹ *Id.* at 205 (quoting R.F.M.A.S., Inc. v. Mimi So, 619 F. Supp. 2d 39, 77 (S.D.N.Y. 2009)).

⁶⁰² *Id.* (quoting Yurman Design, Inc. v. PAJ, Inc., 262 F.3d 101, 115 (2d Cir. 2001)).

⁶⁰³ *Id.* (citing 15 U.S.C. § 43(a)(1)(A) (2018)).

⁶⁰⁴ *See, e.g.*, Kodiak Cakes LLC v. Cont’l Mills, Inc., 358 F. Supp. 3d 1219, 1225 (D. Utah 2019) (holding, in order granting preliminary injunction motion and without extended analysis, that plaintiff had sufficiently articulated trade dress comprising two protein pancake mix packages).

⁶⁰⁵ *See* Smartling, Inc. v. Skawa Innovation Ltd., 358 F. Supp. 3d 124 (D. Mass. 2019).

the [mark].”⁶⁰⁶ Those details in the operative pleading, the court held, merited a denial of the defendants’ motion.⁶⁰⁷

Likewise, a manufacturer of a ballet flat shoe survived a motion to dismiss for failure to define its claimed product configuration trade dress in sufficient detail to alert the defendants to the nature of its claims.⁶⁰⁸ The plaintiff’s complaint was not exactly verbose in describing the shoe in question; instead, that description was apparently limited to recitations that “[the shoe] has a distinctive shape and design such that it is recognized by consumers of footwear”⁶⁰⁹ and that “[t]he signature round toe with a distinctive pointed vamp, seamless 3D knitted upper, slim profile and sleek outsole of [the shoe] the trade dress”⁶¹⁰ Nevertheless, the complaint also included “several side-by-side graphical comparisons” of the parties’ goods,⁶¹¹ which, combined with the verbal descriptions of the plaintiff’s shoe, allowed it to escape dismissal.

The incorporation of graphics into a complaint also proved a good strategy for a plaintiff claiming trade dress rights in the “ornamental design of [a roller shade] jamb bracket, center bracket, and end bracket.”⁶¹² Seeking the complaint’s dismissal, the defendants argued that the plaintiff had failed to define the elements of its claimed trade dress with the required precision, but the court disagreed. It first noted that “the Complaint describes the shape and composition of Plaintiff’s trade dress, as well as its overall look.”⁶¹³ Of equal importance, it found, “[t]he Complaint goes on to describe each individual element in detail, with photographs for illustration.”⁶¹⁴ The plaintiff therefore had adequately described the elements of its claimed trade dress to survive a motion to dismiss.⁶¹⁵

⁶⁰⁶ *Id.* at 147.

⁶⁰⁷ *Id.*

⁶⁰⁸ *See* *Rothy’s, Inc. v. JKM Techs., LLC*, 360 F. Supp. 3d 373 (W.D. Va. 2018).

⁶⁰⁹ *Id.* at 381.

⁶¹⁰ *Id.*

⁶¹¹ *Id.*

⁶¹² *GeigTech E. Bay LLC v. Lutron Elecs. Co.*, 352 F. Supp. 3d 265, 273 (S.D.N.Y. 2018).

⁶¹³ *Id.* at 277.

⁶¹⁴ *Id.*

⁶¹⁵ *Id.* at 278.

ii. Establishing Protectable Rights
(A) The Effect of Registrations on the
Mark-Validity Inquiry
(1) Federal Registrations

If a claimed mark is not registered on the Principal Register, its owner bears the burden of proving the mark's validity.⁶¹⁶ In contrast, even if the owner of a registration on the Principal Register has not yet filed a declaration of incontestability under Section 15,⁶¹⁷ Sections 7(b) and 33(a) of the Act both recognize the registration as "prima facie evidence" of the validity of the registered mark.⁶¹⁸ In the context of inter partes litigation, the Federal Circuit has long applied the majority rule that prima facie evidence of validity effects a shift in the burden of proof to the challenger of a registered mark's validity.⁶¹⁹ Improbably, however, that court did not until last year have the opportunity to address the issue in an infringement action originally brought before the International Trade Commission, which required the court to apply its own law, rather than that of a regional circuit.⁶²⁰ The court resolved the issue in the registrant's favor, seeing "no reason why the effect of the presumption should be any different in the infringement context," which was a "result . . . strongly supported by the legislative history of the Lanham Act as thoroughly documented by [an academic article]."⁶²¹ Significantly, though, it qualified that holding with its conclusion that "[the plaintiff's] registration confers a presumption of secondary meaning beginning only as of the date of registration and confers no presumption of secondary meaning before the date of registration."⁶²²

The Eighth Circuit concurred in part with the Federal Circuit's approach to the prima facie evidence of validity represented by a

⁶¹⁶ See, e.g., *Bodum USA, Inc. v. A Top New Casting Inc.*, 927 F.3d 486, 492 (7th Cir. 2019) ("Where, as here, the claimed trade dress is unregistered, it is the burden of the party asserting protection to prove that the trade dress is not functional.").

⁶¹⁷ 15 U.S.C. § 1065 (2018)

⁶¹⁸ *Id.* §§ 1057(b), 1115(a).

⁶¹⁹ See, e.g., *Cold War Museum, Inc. v. Cold War Air Museum, Inc.*, 586 F.3d 1352, 1356 (Fed. Cir. 2009) ("Due to this presumption of validity, the burden of persuasion in a cancellation proceeding rests on the party seeking to cancel the registration.").

⁶²⁰ See *Converse, Inc. v. Int'l Trade Comm'n*, 909 F.3d 1110 (Fed. Cir. 2018).

⁶²¹ *Id.* at 1117 (citing Charles L. Cook & Theodore H. Davis Jr., *Litigating the Meaning of "Prima Facie Evidence" Under the Lanham Act: The Fog and Art of War*, 103 TMR 437, 459-86 (2013)).

⁶²² *Id.* at 1118. "Thus," the court further explained, "with respect to infringement by those respondents whose first uses came before the registration (including all of the intervenors), [the plaintiff] must establish without the benefit of the presumption that its mark had acquired secondary meaning before the first infringing use by each respondent." *Id.*

registration under Sections 7(b) and 33(a).⁶²³ Addressing a claim that several marks covered by “still contestable” registrations were invalid, the former court agreed with the latter court by noting that “the defendants had the burden to prove it.”⁶²⁴ Like the Federal Circuit, the Eighth Circuit then qualified that proposition by holding that “[a] registrant is not entitled to the presumption . . . if he alleges that the purported infringer started to infringe a mark registered under Section 2(f) before the mark’s date of registration.”⁶²⁵ With respect to other registrations owned by the plaintiff that had not issued under Section 2(f), however, the Eighth Circuit concluded that “[the plaintiff] is entitled to a presumption that the mark is valid even if the alleged infringement began before the mark’s date of registration.”⁶²⁶

The Federal Circuit and the Eighth Circuit were not alone in applying what the former court properly characterized as the majority rule on the burden-of-proof-shifting effect of *prima facie* evidence of mark validity.⁶²⁷ The Sixth Circuit did so, holding that “[o]nce registered, a mark becomes presumptively valid, placing the burden of proof and production on anyone challenging the mark.”⁶²⁸ Likewise, a Washington federal district court noted the rule reflected in most (but not all) Ninth Circuit opinions, namely, that “registration provides . . . a ‘presumption of validity’ and shifts the burden to the defendant to prove otherwise.”⁶²⁹ The latter court, however, declined to excuse the owner of a federal registration covering a composite mark from proving the validity of the verbal component of the mark independent of its design component.⁶³⁰

Other courts applied the minority rule by holding that “[t]he effect of a successful registration of a trademark is to shift [only] the burden of production . . . to the party seeking to prove that the mark is [invalid].”⁶³¹ Chief among them was the Seventh Circuit, which in

⁶²³ See *Sturgis Motorcycle Rally, Inc. v. Rushmore Photo & Gifts, Inc.*, 908 F.3d 313 (8th Cir. 2018).

⁶²⁴ *Id.* at 336-37.

⁶²⁵ *Id.* at 323 (citing 15 U.S.C. § 1052(f) (2018)).

⁶²⁶ *Id.* at 336.

⁶²⁷ See, e.g., *Can’t Live Without It, LLC v. ETS Express, Inc.*, 373 F. Supp. 3d 434, 442 (S.D.N.Y. 2018) (“[B]ecause [the plaintiff] registered its trade dress with the Patent and Trademark Office in January 2017, [the defendant] bore the burden of proving that it had no secondary meaning after that time. However, [the plaintiff] still had the burden of proving that its bottle had acquired secondary meaning before the [defendant’s allegedly infringing trade dress] entered the market in the summer of 2014.” (citations omitted)); see also *ZP No. 314, LLC v. ILM Capital, LLC*, 335 F. Supp. 3d 1242, 1256 (S.D. Ala. 2018).

⁶²⁸ *Ausable River Trading Post, LLC v. Dovetail Sols., Inc.*, 902 F.3d 567, 570 (6th Cir. 2018).

⁶²⁹ *Comphy Co. v. Amazon.com, Inc.*, 371 F. Supp. 3d 914, 922 (W.D. Wash. 2019).

⁶³⁰ *Id.* at 923.

⁶³¹ *Express Homebuyers USA, LLC v. WBH Mktg., Inc.*, 343 F. Supp. 3d 562, 567 (E.D. Va. 2018), *appeal docketed*, No. 18-2353 (4th Cir. Nov. 13, 2018); see also *Express*

recent years has departed from its earlier applications of the majority rule⁶³² in favor of viewing prima facie evidence in the same manner as a presumption under Rule 301 of the Federal Rules of Evidence, or, in other words, as having merely a burden-of-production-shifting effect.⁶³³ The court noted that some commentators, including the authors of the article found persuasive by the Federal Circuit, had criticized its approach as “out of step with the ‘majority rule,’ which imposes on the defendant both the burden of production (which we have recognized) and the burden of persuasion (which we generally have not).”⁶³⁴ Nevertheless, it noted, “[n]either party asks us to reconsider our standard, and we see no reason to do so in this case.”⁶³⁵

(2) State Registrations

The significance of state registrations to the mark-validity inquiry played a role in few reported opinions. One exception to that general trend came from a Colorado federal district court entertaining a clash between two claimants to a mark not covered by a federal registration owned by either side.⁶³⁶ The plaintiff submitted a state registration of its version of the disputed mark in support of a preliminary injunction, but the court dismissed that proffer by holding in a footnote that “state trademark registration has no effect on the parties’ Lanham Act claims”;⁶³⁷ moreover, the registration played no apparent role in the court’s disposition of the plaintiff’s claims under Colorado state law.

Homebuyers USA, LLC v. WBH Mktg. Inc., 323 F. Supp. 3d 784, 790 (E.D. Va. 2018) (“If the party challenging the registration presents sufficient evidence that the marks are generic, then the presumption of validity of the trademark is rebutted.”), *reconsideration denied*, No. 1:17-CV-736, 2018 WL 6616675 (E.D. Va. Aug. 29, 2018), *appeal docketed*, No. 18-2149 (4th Cir. Oct. 2, 2018).

⁶³² See, e.g., Publ’ns Int’l, Ltd. v. Landoll, Inc., 164 F.3d 337, 339-40 (7th Cir. 1998) (“[R]egistration creates a presumption of validity, implying that the defendant has the laboring oar on all issues relating to validity”); Thomas & Betts Corp. v. Panduit Corp., 138 F.3d 277, 301 (7th Cir. 1998) (“[T]he presumption of validity can be rebutted. For this to occur, [the counterclaim defendant] must meet its burden by providing proof of genericness.”), *overruled in part on other grounds*, Traffix Devices, Inc. v. Mktg. Displays, Inc., 532 U.S. 23 (2001).

⁶³³ See Uncommon, LLC v. Spigen, Inc., 926 F.3d 409 (7th Cir. 2019).

⁶³⁴ *Id.* at 421 n.5 (citing Charles L. Cook & Theodore H. Davis Jr., *Litigating the Meaning of “Prima Facie Evidence” Under the Lanham Act: The Fog and Art of War*, 103 TMR 437, 459-86 (2013)).

⁶³⁵ *Id.*

⁶³⁶ See Dalkita, Inc. v. Distilling Craft, LLC, 356 F. Supp. 3d 1125 (D. Colo. 2018).

⁶³⁷ *Id.* at 1137 n.8.

(B) Ownership

The leading ownership dispute addressed by a reported opinion arose in a battle between the city of New Orleans and one of its agencies (the two counterclaim plaintiffs), on the one hand, and a commercial tenant of the agency and its affiliates (the counterclaim defendants), on the other.⁶³⁸ The disputed mark was ST. ROCH MARKET, which the parties agreed had appeared on signage at a market since the late 1880s; a food hall in the market was the subject of the counterclaim defendants' lease with the agency. Based on the contractual relationship between the parties, the court observed that “[t]he critical question in this case is whether the landlord (as owner of the food hall) has seniority over the tenant (as operator of the food hall).”⁶³⁹ Surveying the doctrinal landscape on that issue, it held that “if the tenant creates the mark and owns the business with which the mark is associated, the tenant owns the mark. But the rule is otherwise where the business has become inseparably identified with a particular building.”⁶⁴⁰ Noting that “[a] number of courts have held that the name of a public building used in commerce belongs to the owner of that building,”⁶⁴¹ the court resolved the issue in favor of the counterclaim plaintiffs. As it explained based on the preliminary injunction record assembled by those parties, “[t]he [counterclaim plaintiffs’] use of the mark has not been transitory and it achieved secondary meaning well before [counterclaim] defendants acquired the lease in 2014. The [counterclaim plaintiffs] also designed and built the market, chose its lessees, and made significant investments to restore it after Hurricane Katrina.”⁶⁴² Although the counterclaim plaintiffs had themselves never “actually operated a market—or any other type of food service—in the building”⁶⁴³ and although the terms of the lease between the parties left much to be desired from a trademark perspective, those circumstances did not merit a different result.⁶⁴⁴

(C) The Common-Law Requirements for Mark Validity

(1) Use in Commerce

Prior use is a prerequisite for common-law trademark rights. Indeed, the Supreme Court opined over a century ago in a common-

⁶³⁸ See *Helpful Hound, L.L.C. v. New Orleans Bldg. Corp.*, 331 F. Supp. 3d 581 (E.D. La. 2018).

⁶³⁹ *Id.* at 597.

⁶⁴⁰ *Id.* (citation omitted)

⁶⁴¹ *Id.*

⁶⁴² *Id.* at 598.

⁶⁴³ *Id.*

⁶⁴⁴ *Id.* at 599.

law action that “as between conflicting claimants to the right to use the same mark, priority of appropriation determines the question.”⁶⁴⁵ Moreover, use in commerce is for all practical purposes required for enforcement actions under the Lanham Act: “Demonstrating use in commerce is a threshold burden because no activity is actionable under the Lanham Act absent the use of a trademark.”⁶⁴⁶

***(a) The Nature and Quality of Use in Commerce
Necessary to Establish Protectable Rights***

Prior use of a distinctive and nonfunctional mark in connection with particular goods or services will create protectable rights under federal law vis-à-vis a junior user, but will it do so with respect to all channels of distribution for those goods or services? The Second Circuit addressed that question in an appeal from a district court opinion that answered it in the negative.⁶⁴⁷ The counterclaim plaintiff in the dispute leading to the appeal was a commercial brewery that began using the ROGUE mark on clothing, including T-shirts, hats, sweatshirts, aprons, and similar apparel in 1989. Although the counterclaim plaintiff originally sold its goods in its proprietary pubs, brewery, bed-and-breakfasts, and hop farm, it had expanded to mail-order sales and those at beer festivals throughout the country by the mid-1990s. Those uses of its mark occurred prior to the counterclaim plaintiff’s use of its version of the ROGUE mark for leather coats and jackets, which began in 2000. Although the parties coexisted uneasily for a number of years, open hostilities broke out when they found themselves selling their respective ROGUE-branded goods in department stores and stores that sold only clothing.

On the parties’ cross-motions for summary judgment, the district court held the counterclaim defendant enjoyed prior rights to the disputed mark in department stores and clothing-only stores because its circa-2009 entry into those channels of distribution predated the counterclaim plaintiff’s circa-2011 entry. That holding did not survive scrutiny on appeal, however, for the Second Circuit rejected the district court’s assumption that “[a mark] owner’s rights are limited to the types of stores in which the owner has previously exploited the mark.”⁶⁴⁸ As it explained:

⁶⁴⁵ United Drug Co. v. Theodore Rectanus Co., 248 U.S. 90, 100 (1918).

⁶⁴⁶ Gym Door Repairs, Inc. v. Young Equip. Sales, Inc., 331 F. Supp. 3d 221, 250 (S.D.N.Y.) (quoting Gelocity UK Ltd. v. Jell-E-Bath, Inc., No. 10cv5677, 2013 WL 3315398, at *3 (E.D.N.Y. July 1, 2013)), *reconsideration denied*, No. 15-CV-4244 (JGK), 2018 WL 5650004 (S.D.N.Y. Oct. 30, 2018).

⁶⁴⁷ See Excelled Sheepskin & Leather Coat Corp. v. Or. Brewing Co., 897 F.3d 413 (2d Cir. 2018).

⁶⁴⁸ *Id.* at 418.

The law does not limit the owner's trademark rights to the types of stores in which it has sold, leaving the mark up for grabs in any other type of store. The fact that, prior to 2011, [the counterclaim plaintiff] did not sell in department stores and clothing-only stores does not mean that a new user was free to usurp [the counterclaim plaintiff's] priority in such stores. To be sure, the senior user of a mark does not preserve its priority as to expansion into other unrelated goods or services. But expanding into new product lines in which someone else has priority is different from beginning to sell the goods on which one has nationwide priority in a new category of stores (where a junior user is making infringing sales under the senior user's mark).⁶⁴⁹

The counterclaim plaintiff, and not the counterclaim defendant, therefore was entitled to judgment as a matter of law where the issue of priority was concerned.

An additional federal appellate opinion addressing the issue of use in commerce came in an Eleventh Circuit opinion.⁶⁵⁰ The counterclaim plaintiff in the action was a Brazil-based operator of an online retail store that successfully had challenged as cybersquatting the registration by an Internet domain name acquisition company of a domain name incorporating the counterclaim plaintiff's mark. On appeal, the counterclaim defendant urged the court to find as a matter of law that the counterclaim plaintiff had failed to prove it had used its mark in commerce before the counterclaim defendant's registration of the disputed domain name. Citing to the Supreme Court's test for evaluating the propriety of an extraterritorial application of the Act in *Steele v. Bulova Watch Co.*,⁶⁵¹ the counterclaim defendant urged the court to require a showing that the counterclaim plaintiff's prior use of its mark had had "substantial effects" within the United States.⁶⁵²

Not surprisingly, the court declined to reach such a holding, concluding instead that the counterclaim defendant had confused the separate and independent concepts of priority of rights with federal subject-matter jurisdiction.⁶⁵³ Addressing the former concept, it held, "evidence showing, first, adoption, and, second, use in a way sufficiently public to identify or distinguish the marked goods in an appropriate segment of the public mind as those of the adopter of the mark, is competent to establish ownership, even

⁶⁴⁹ *Id.* (citations omitted).

⁶⁵⁰ See *Direct Niche, LLC v. Via Varejo S/A*, 898 F.3d 1144 (11th Cir. 2018).

⁶⁵¹ 344 U.S. 280 (1952).

⁶⁵² *Direct Niche*, 898 F.3d at 1149.

⁶⁵³ *Id.* at 1150 ("[A]lthough both the jurisdictional and the ownership tests require analysis of a trademark's 'use in commerce,' the tests are nonetheless distinct.").

without evidence of actual sales.”⁶⁵⁴ Then, reviewing the trial record, it affirmed the district court’s factual finding of prior use based on the counterclaim plaintiff’s entry into contracts with United States companies to advertise those companies’ goods on the counterclaim plaintiff’s website, as well as testimony by the counterclaim plaintiff’s marketing director of millions of visits to that site by IP addresses located in the United States.⁶⁵⁵ As it concluded, “[t]he district court’s conclusion that this evidence demonstrates sufficient public use in commerce to establish ownership of the mark is not clearly erroneous.”⁶⁵⁶

Another opinion, one from a California federal district court, addressed the extent to which the name of a fictional product in a creative work can serve as a valid mark.⁶⁵⁷ The disputed mark at issue was SABACC for a card game prominently featured in the *Star Wars* franchise of motion pictures and other works. Although the plaintiffs—Lucasfilm Ltd. and an affiliate—sufficiently averred the existence of a licensing program as to defeat the defendants’ motion to dismiss the plaintiffs’ complaint, the court found an additional basis for the plaintiffs’ priority of rights. That basis was the proposition that “fictional elements of expressive works can function as trademarks when those elements symbolize the plaintiff or its product to the consuming public.”⁶⁵⁸ The court held that symbolism apparent in the allegations of the complaint:

Here, [the plaintiffs] allege[] that Sabacc is a fictional element of the *Star Wars* universe, and that the game is associated with an important episode in the franchise’s storyline—Han Solo’s acquisition of his famous *Millennium Falcon*. The game has appeared in *Star Wars* novels, games, television episodes, and a visual dictionary. As a consequence, the word “Sabacc” signifies Lucasfilm and the *Star Wars* franchise in the minds of the consuming public. At the pleading stage, [the plaintiffs] [have] made a sufficient showing to survive a motion to dismiss.⁶⁵⁹

Other courts viewed claims of priority far more skeptically. In a hard-line application of the use-in-commerce prerequisite for protectable rights, a Colorado federal district court took a hard line toward a group of defendants seeking to establish priority of rights to a mark used in connection with a podcast and a website aimed at

⁶⁵⁴ *Id.* (alteration omitted) (quoting *Planetary Motion, Inc. v. Techsplosion, Inc.*, 261 F.3d 1188, 1195 (11th Cir. 2001)).

⁶⁵⁵ *Id.* at 1150-51.

⁶⁵⁶ *Id.* at 1151.

⁶⁵⁷ *See Lucasfilm Ltd. v. Ren Ventures Ltd.*, 126 U.S.P.Q.2d 1515 (N.D. Cal. 2018).

⁶⁵⁸ *Id.* at 1518.

⁶⁵⁹ *Id.* at 1599.

distillers.⁶⁶⁰ According to the defendants, they had: (1) conceived of and created the mark; (2) designed a logo presentation of it; (3) purchased a domain name incorporating it; (4) created a website accessible at the domain name; (5) solicited prospective viewers of the podcast via the website; and (6) “told ‘a couple hundred’ people” at an industry conference about the website.⁶⁶¹ The court acknowledged case law holding that trademark rights could vest prior to actual sales, but it found on the plaintiff’s motion for a preliminary injunction that the defendants’ showing fell short of the mark. As it concluded from the record, “[t]he only evidence presented regarding the number of visitors to the site during that time period was . . . testimony [by the principal of the lead defendant] that a handful of family and friends and one ‘random guy’ signed up to received [sic] the podcast. This evidence does not support an inference that defendants’ pre-sales use of the mark had a ‘substantial impact’ on the consuming public.”⁶⁶²

Another opinion emanating from the same district also declined to recognize a claim of priority grounded in something resembling a zone-of-natural-expansion argument.⁶⁶³ Prior to entering the retail banking business in the state of Colorado, a financial institution operated by defendants under the CENTRAL BANK mark began servicing flexible spending accounts for Colorado state employees. It also acted as contractor for the Colorado Department of Natural Resources to process payments for hunting and fishing licenses, although it no longer provided that service by 2008, two years before the plaintiff’s first use of its CENTRAL BANK & TRUST mark. On these facts, the court was disinclined to allow the defendants to claim prior rights for retail banking services:

Even if the hunting and fishing license service had not ended in 2008 (before Central Bank & Trust opened), neither that service nor the FSA service exposed Colorado consumers to “Central Bank” as a brand in any appreciable way. For those receiving FSA reimbursement checks, for example, it is unclear how many noticed or even thought about the notion that Central Bank of Jefferson City, Missouri, had issued the check. . . . And only employees at hunting and fishing license vendors would have had any reason to see that a bank named “Central Bank” was on the other side of the transaction.⁶⁶⁴

⁶⁶⁰ See *Dalkita, Inc. v. Distilling Craft, LLC*, 356 F. Supp. 3d 1125 (D. Colo. 2018).

⁶⁶¹ *Id.* at 1376.

⁶⁶² *Id.* at 1138 (quoting *T.A.B. Sys. v. Pactel Teletrac*, 77 F.3d 1372, 1376 (Fed. Cir. 1996)).

⁶⁶³ See *Cent. Bancorp, Inc. v. Cent. Bancompany, Inc.*, 385 F. Supp. 3d 1122 (D. Colo. 2019).

⁶⁶⁴ *Id.* at 1139.

Thus, beyond the absence of Tenth Circuit authority holding that “the related goods doctrine can establish priority of use” as legal proposition,⁶⁶⁵ the defendants’ argument lacked factual support.

Of course, some opinions addressed claims of priority in the context of unsuccessful motions for summary judgment. One such motion was pursued by a defendant seeking to establish its priority of rights to the MAVEN GIG mark for an agnostic platform through which drivers could drive for any ride share or delivery business.⁶⁶⁶ Drivers enrolling in a pilot program for the platform were exposed to the mark only once before signing up:⁶⁶⁷

I agree to Maven Gig's [Lease Agreement](#) and [Privacy Statement](#)

Save and Continue

Although the mark appeared in a post-enrollment confirmation e-mail, it did so in running text, rather than in an attention-getting presentation. By the time the plaintiff publicly used its GIG mark for closely similar services, 284 customers had availed themselves of the defendant’s pilot program.

The court denied the defendant’s motion for summary judgment in terms making clear it would have reached the same conclusion had it been deciding the issue at trial. To begin with, it found, “the limited mention of MAVEN GIG at the end of the first screen of the Enrollment Website does not constitute sufficient use ‘in conjunction with’ the actual sale of the service.”⁶⁶⁸ Worse still, the MAVEN mark appeared on a standalone basis in numerous portions of the defendant’s various agreements with drivers, of which the court remarked that “[t]he prominent use of the Maven mark instead of the MAVEN GIG mark during the enrollment process may diminish ‘the public’s ability to associate a single mark’ with the service ‘as it is unclear which mark to attach to the [service].”⁶⁶⁹ The court next found that “[b]esides the statement next to the check box, the only thing that comes close to mentioning the MAVEN GIG mark during the enrollment process were the hyperlinks in the emails to the Uber drivers, including www.mavendrive.com/gig/#!enroll and www.mavendrive.com/gig/#!/emailConfirm/”; those uses failed to get

⁶⁶⁵ *Id.* at 1138.

⁶⁶⁶ *See Am. Auto. Ass’n of N. Cal., Nevada & Utah v. Gen. Motors LLC*, 367 F. Supp. 3d 1072 (N.D. Cal. 2019).

⁶⁶⁷ *Id.* at 1082.

⁶⁶⁸ *Id.* at 1092.

⁶⁶⁹ *Id.* at 1093 (second alteration in original) (quoting *Nexsan Techs., Inc. v. EMC Corp.*, 260 F. Supp. 3d 68, 77 (D. Mass. 2017)).

the job because “using a hyperlink or a domain name in e-mail communications is not sufficient to establish priority.”⁶⁷⁰ Finally, it rejected the defendants’ reliance on the post-enrollment confirmation e-mails sent to participants in the pilot program, holding, “the emails themselves are private one-on-one communications with individuals, not public use of the mark. As such, the reservation confirmation and reservation update emails do not support a finding of use.”⁶⁷¹

Likewise, addressing a priority dispute between directly competitive businesses using identical marks, a Washington federal district court declined to resolve the issue of priority on a defense motion for summary judgment.⁶⁷² The gravamen of that motion was the plaintiff’s apparent inability to produce convincing documentary evidence backing up its claim of prior use. In lieu of that documentation, the plaintiff proffered seven declarations describing its use of the disputed mark. Although the defendant objected to two of the declarations because the plaintiff had failed to disclose the witnesses giving them, that left five others executed by officers and employees of the plaintiff, all of whom worked for the plaintiff prior to the defendant’s claimed date of first use. Especially because the defendant did not dispute the proposition that verbal use of a claimed mark can qualify as a use in commerce for priority purposes, the absence of documentary evidence supporting the plaintiff’s claim of priority did not entitle the defendant to summary judgment; moreover, this was true although “the declarations are not particularly detailed and contain similar or identical language”⁶⁷³

(b) Use Through Licensees

The claimant to a mark need not itself use the mark in commerce to acquire protectable rights; rather, as reflected in Section 5 of the Act,⁶⁷⁴ properly licensed uses can do the job; thus, “the goodwill arising from a licensed brand belongs to the licensor, not the licensee.”⁶⁷⁵ Nevertheless, a Fifth Circuit opinion concluded (dubiously) that all not properly worded licenses will do the trick.⁶⁷⁶ Although the plaintiffs had licensed the defendants to use the marks

⁶⁷⁰ *Id.* at 1094.

⁶⁷¹ *Id.* at 1095.

⁶⁷² *See* *Clean Crawl, Inc. v. Crawl Space Cleaning Pros, Inc.*, 364 F. Supp. 3d 1194 (W.D. Wash. 2019).

⁶⁷³ *Id.* at 1213.

⁶⁷⁴ 15 U.S.C. § 1065 (2018).

⁶⁷⁵ *Izabella HMC-MF, LLC v. Radisson Hotels Int’l, Inc.*, 378 F. Supp. 3d 775, 779 (D. Minn. 2019) (denying preliminary injunction against termination of plaintiff as defendant’s franchisee).

⁶⁷⁶ *See* *Uptown Grill, L.L.C. v. Camellia Grill Holdings, Inc.*, 920 F.3d 243 (5th Cir. 2019).

and trade dress at the heart of the parties' dispute, that license followed a transaction in which the plaintiffs had assigned their rights to the marks and trade dress to the defendants. Under ordinary circumstances, the merger doctrine would have extinguished any preexisting rights to the marks and trade dress enjoyed by the defendants.⁶⁷⁷ But, whether because the plaintiffs failed to raise the point or otherwise, the court gave the earlier, and not the later, agreement between the parties greater weight, which meant, in its view, the plaintiffs did not have rights to license when they purported to do so.⁶⁷⁸

In contrast, a panel of the Court of Appeals of Washington displayed a better understanding of the acquisition of use-based rights through licensees.⁶⁷⁹ The plaintiff in the action before that court was a California-based cannabis concentrate business that alleged infringement of its mark by the Washington-based defendant. Although the plaintiff did not have a Washington presence, it did have a licensee, and the court concluded the licensee's use of the plaintiff's mark inured to the benefit of the plaintiff in Washington. Addressing the question of the plaintiff's rights in the state, it held that "[i]t is an established principle of the common law of trademark that indirect use of a protected mark by a licensee inures to the benefit of the owner of the mark when the owner has sufficient control over the quality of the goods or services provided to customers under the licensed mark."⁶⁸⁰

So far, so good, as far as doctrinal licensing principles were concerned. But the absence of the plaintiff itself from Washington was due to a prohibition on out-of-state companies receiving the state license necessary to operate there, which led the defendant to argue that any licensed use of the plaintiff's mark within the state was necessarily unlawful. It based that argument on provisions of the license granting the plaintiff control over the nature and quality of the goods sold by the plaintiff's licensee, which allegedly rendered the plaintiff a "true party [in] interest" for purposes of state law.⁶⁸¹ The court was unconvinced, holding instead that "[the plaintiff's] alleged licensing agreement with [its licensee] does not necessarily

⁶⁷⁷ *See Dress for Success Worldwide v. Dress 4 Success*, 589 F. Supp. 2d 351, 359 (S.D.N.Y. 2008) ("Under the merger rule, 'A licensee's prior claims of any independent rights to a trademark are lost, or merged into the license, when he accepts his position as licensee, thereby acknowledging the licensor owns the marks and that his rights are derived from the licensor and enure to the benefit of the licensor.'" (quoting *Bunn-O-Matic Corp. v. Bunn Coffee Serv., Inc.*, 88 F. Supp. 2d 914, 923 (C.D. Ill. 2000)).

⁶⁷⁸ *Uptown Grill*, 920 F.3d at 250.

⁶⁷⁹ *See Headspace Int'l LLC v. Podworks Corp.*, 428 P.3d 1260 (Wash. Ct. App. 2018), *review denied*, 435 P.3d 269 (2019).

⁶⁸⁰ *Id.* at 1264-65.

⁶⁸¹ *Id.* at 1268-69.

require that [the plaintiff] participate in [the licensee's] processing of marijuana products.”⁶⁸² Rather:

[The plaintiff's] alleged licensing agreement arranged for [the plaintiff] to provide [its licensee] with the formula or recipe for processing cannabis concentrates and the right to place [the plaintiff's] mark on those concentrates [the licensee] processed using said formula or recipe. The agreement as alleged did not require [the plaintiff] to actually participate in the processing or sale of those products.⁶⁸³

A more conventional licensing program led to the denial of a motion to dismiss a complaint for infringement and unfair competition filed by two Lucasfilm entities.⁶⁸⁴ The mark at issue was SABACC, which originally referred to a fictional card game featured in various STAR WARS-branded films and other creative works. In response to the plaintiffs' challenge to its registration and use of the same mark for a real-life card game, the defendants argued, as the court put it, that “the name of a fictional good or service in an expressive work does not function as a mark for that fictional good or service.”⁶⁸⁵ In holding that the plaintiffs had adequately stated trademark-based claims, the court held:

[The plaintiffs] do[] not claim ownership of the “Sabacc” mark as a source identifier for a fictional card game product. Rather, “Sabacc” functions as a mark for [the plaintiffs] and the *Star Wars* franchise, which are real entities that exist in commerce. *Star Wars* has extensive licensing and merchandising arms that make use of the franchise's fanciful elements in order to sell entertainment products, including Sabacc card game products. The crux of [the plaintiffs'] claims is that defendants use the “Sabacc” mark with the intention that consumers associate their unlicensed product with the *Star Wars* franchise and its licensed products.⁶⁸⁶

The plaintiffs' licensing program therefore sufficed to establish prior rights to the disputed mark.

(c) Use-Based Geographic Rights

One of the most important benefits of a federal registration on the Principal Register is the nationwide constructive priority

⁶⁸² *Id.* at 1266.

⁶⁸³ *Id.*

⁶⁸⁴ *See* Lucasfilm Ltd. v. Ren Ventures Ltd., 126 U.S.P.Q.2d 1515 (N.D. Cal. 2018).

⁶⁸⁵ *Id.* at 1518.

⁶⁸⁶ *Id.*

attaching to the registration under Section 7(c) of the Act.⁶⁸⁷ Nevertheless, under the *Dawn Donut* doctrine,⁶⁸⁸ a federal registrant is entitled to enjoin a remote junior user of the mark only if there is a likelihood of the registrant's entry into the disputed territory. In other words, the registrant has a nationwide *right*, but the injunctive *remedy* does not ripen until the registrant has taken concrete plans to enter that territory.

A Texas federal district court squarely addressed the continued viability of *Dawn Donut* in the Internet age.⁶⁸⁹ The plaintiff advanced two arguments in an attempt to secure injunctive relief against the defendants' geographically remote use of what otherwise might be an infringing mark, namely, that "the Fifth Circuit has not recently applied the doctrine and the growth of ecommerce [has] made geographic boundaries near-irrelevant in business."⁶⁹⁰ Referencing the seat of the Fifth Circuit, the court disposed of the first argument by holding that "[r]eversing the adoption of *Dawn Donut* must be addressed in New Orleans."⁶⁹¹ Although expressing some sympathy for the plaintiff's second argument, the court rejected it as well because:

[A]t the time of *Dawn Donut*, geographical economic boundaries were already a dissolving relic. The internet certainly seems revolutionary—and the Court will not destroy its credibility by claiming otherwise—but in commerce mail-order businesses like Sears, Roebuck & Co. were well-established by the 1950s. They gave consumers the ability to buy goods from across the country without regard to geographic boundaries. It was an internet before the internet. Thus, the Second and Fifth Circuits accepted *Dawn Donut's* reasoning despite the known irrelevance of geographic borders in commerce. In fact, by the time of the Fifth Circuit's last citation to *Dawn Donut* in 1997, the internet, eBay, and Amazon existed. The Court cannot conclude the Fifth Circuit's acceptance of *Dawn Donut* was unknowing of modern electronic commerce.⁶⁹²

The court therefore confirmed *Dawn Donut's* applicability as an affirmative defense—a characterization at odds with the usual placement of the burden of proof on the plaintiff to demonstrate

⁶⁸⁷ 15 U.S.C. § 1057(c) (2018).

⁶⁸⁸ See *Dawn Donut Co. v. Hart's Food Stores, Inc.*, 267 F.2d 358, 362 (2d Cir. 1959).

⁶⁸⁹ See *Cross Trailers, Inc. v. Cross Trailer Mfg. & Sales, LLC*, 363 F. Supp. 3d 774 (W.D. Tex. 2018).

⁶⁹⁰ *Id.* at 782.

⁶⁹¹ *Id.*

⁶⁹² *Id.* (footnote omitted) (citations omitted) (citing *Exxon Corp. v. Oxxford Clothes, Inc.*, 109 F.3d 1070, 1078 (5th Cir. 1997)).

overlapping geographic markets.⁶⁹³ It then found that evidence and testimony of three things created a factual dispute precluding a grant of the defendants' motion for summary judgment under *Dawn Donut*: (1) the "overlapping national dealership bases of the parties";⁶⁹⁴ (2) a geographic overlap in the parties' end users;⁶⁹⁵ and (3) the parties' national advertising presence.⁶⁹⁶

If neither the senior user nor the junior user to a trademark dispute owns a federal registration on the Principal Register, the *Dawn Donut* doctrine obviously does not apply, and the metes and bounds of the parties' geographic rights are governed by the complementary *Tea Rose-Rectanus* doctrine. Under it, an absolute senior user's rights ordinarily will be limited to the geographic areas in which it does business, or, possibly, its zone of natural expansion.⁶⁹⁷ As set forth by the Supreme Court, that general rule is subject to a significant exception in cases in which "the second adopter has selected the mark with some design inimical to the interests of the first user, such as to take the benefit of the reputation of his goods, to forestall the extension of his trade, or the like."⁶⁹⁸ Nevertheless, since the Court articulated it in 1916, that exception has raised a question the Court has not attempted to resolve since then. That question is whether, if the exception applies, an absolute senior user is entitled to immediate injunctive relief against a remote junior user or, alternatively, only when the parties share overlapping geographic markets.

One court finding that the exception applied opted for the first of these two approaches.⁶⁹⁹ The preliminary injunction record established that the counterclaim plaintiffs enjoyed priority of rights to their unregistered ST. ROCH MARKET mark for a market and food hall in a New Orleans neighborhood. In addition to using that mark in New Orleans, the counterclaim defendants planned to do so as well in Miami, Chicago, and St. Louis, and they argued that the plaintiff's right to injunctive relief did not extend to those cities. As the court found, however, "the evidence suggests that defendants

⁶⁹³ See 3 J. Thomas McCarthy, McCarthy on Trademarks and Unfair Competition § 26:34 ("Likelihood of entry' should be equated with a 'probability of entry' . . . [T]he federal registrant should, in the absence of proof of mark reputation in the disputed area, show some concrete, impending plans for entry. For example, it may prove that it has leased premises and is ready, willing and able to commence sales under the registered mark as soon as the court enjoins the junior user, or it may prove that it has licensed the use of the mark for the disputed territory." (footnotes omitted)).

⁶⁹⁴ *Cross Trailers*, 363 F. Supp. 3d at 788.

⁶⁹⁵ *Id.* at 790.

⁶⁹⁶ *Id.* at 790-91.

⁶⁹⁷ See generally *United Drug Co. v. Theodore Rectanus Co.*, 248 U.S. 90 (1918); *Hanover Star Milling Co. v. Metcalf*, 240 U.S. 403 (1916).

⁶⁹⁸ *Hanover Star*, 240 U.S. at 415.

⁶⁹⁹ See *Helpful Hound, L.L.C. v. New Orleans Bldg. Corp.*, 331 F. Supp. 3d 581 (E.D. La. 2018).

intend to capitalize on the goodwill and reputation developed by plaintiffs.”⁷⁰⁰ In particular, the website for the counterclaim defendants’ Miami location was replete with references to New Orleans and the counterclaim plaintiffs’ business there.⁷⁰¹ Because the counterclaim defendant therefore sought to use the disputed mark in bad faith, “[the counterclaim plaintiffs] trademark rights are not limited geographically,”⁷⁰² and preliminary injunctive relief therefore was appropriate even outside of New Orleans.⁷⁰³

Outside the context of the *Dawn Donut* doctrine, a Colorado federal district court addressed the question of whether the relocation of a Missouri-based retail bank’s customers from Missouri to Colorado could give the bank priority of rights in Colorado.⁷⁰⁴ At least on the preliminary injunction record before that court, the answer was no:

Although Defendants have remotely served banking customers in Colorado since the 1950s, Defendants presented only ambiguous evidence of the extent of their penetration into Colorado, and particularly the penetration and recognition of their mark in [the county in which the parties’ services overlapped].

In addition, from what the evidence *does* reveal, most of Defendants’ general banking customers in Colorado came to Colorado from Missouri and maintained their banking relationship with Defendants, or specifically sought out Defendants because of the rights accompanying Defendants’ Missouri sponsorships. Defendants have provided no authority for the proposition that consumers who view a bank specifically as a Missouri brand—and affiliate with it because of its Missouri connections—can establish that brand’s senior rights in another state.⁷⁰⁵

⁷⁰⁰ *Id.* at 599.

⁷⁰¹ For example, the website announced that “St. Roch Market is a contemporary, multi-vendor food hall brand, hailing from New Orleans” and “[t]his popular New Orleans food hall has made its way down to Miami.” *Id.*

⁷⁰² *Id.* at 600.

⁷⁰³ Because the counterclaim plaintiffs did not request a preliminary injunction against the counterclaim defendants’ use of the mark in Miami, the relief entered did not extend to that city. *Id.* at 591, 605.

⁷⁰⁴ See *Cent. Bancorp, Inc. v. Cent. Bancompany, Inc.*, 385 F. Supp. 3d 1122 (D. Colo. 2019).

⁷⁰⁵ *Id.* at 1139.

(2) Distinctiveness

(a) Determining the Inherent Distinctiveness of Verbal and Two-Dimensional Design Marks

(i) Generic Designations

Both the Federal Circuit and the Ninth Circuit have long held that the combination of a generic term and a generic top-level domain is itself generic and therefore unprotectable as a mark, regardless of any evidence of secondary meaning adduced by the claimed mark's owner.⁷⁰⁶ In *Booking.com B.V. v. United States Patent & Trademark Office*,⁷⁰⁷ however, the Fourth Circuit adopted a different take on the issue by affirming a factual finding that the BOOKING.COM mark for hotel booking services was descriptive and therefore protectable upon a showing of secondary meaning. That outcome did not extend to all uses of the claimed mark, and it also depended heavily on the appellate court's deferential attitude toward the district court's reliance on the factual evidence introduced by the claimant at trial, which included the favorable results of a *Teflon* survey and the absence of third-party generic uses of the claimed mark.⁷⁰⁸ Despite the fact-specific nature of the outcome, the Supreme Court granted the USPTO's petition for a writ of certiorari, which posed a single question presented: "Whether the addition by an online business of a generic top-level domain ('.com') to an otherwise generic term can create a protectable trademark."⁷⁰⁹ The Court's answer to this question could have significant effects beyond the protectability of domain names as marks and extend to genericness doctrine generally.

In contrast, a finding of genericness for a similar claimed service mark—which predated the Fourth Circuit's opinion in *Booking.com*—came at the hands of Virginia federal district court.⁷¹⁰ The counterclaim plaintiff began the action with registrations of "webuyhouses.com" and "we buy houses," which it used in connection with the provision of referrals in the field of real estate procurement, the provision of online information in the field of real estate procurement, and various printed materials bearing on real estate topics. Although holding that the counterclaim

⁷⁰⁶ See, e.g., *Advertise.com, Inc. v. AOL Advertising, Inc.*, 616 F.3d 974, 982 (9th Cir. 2010); *In re Hotels.com, L.P.*, 573 F.3d 1300, 1304-06 (Fed. Cir. 2009).

⁷⁰⁷ 915 F.3d 171 (4th Cir.), *as amended* (Feb. 27, 2019), *cert. granted*, No. 19-46, 2019 WL 5850636 (U.S. Nov. 11, 2019).

⁷⁰⁸ *Id.* at 182-84.

⁷⁰⁹ Petition for Writ of Certiorari, at i, *United States Patent & Trademark Office v. Booking.com B.V.*, No. 19-46 (U.S. July 15, 2019).

⁷¹⁰ See *Express Homebuyers USA, LLC v. WBH Mktg. Inc.*, 323 F. Supp. 3d 784 (E.D. Va.), *reconsideration denied*, No. 1:17-CV-736, 2018 WL 6616675 (E.D. Va. Aug. 29, 2018), *appeal docketed*, No. 18-2149 (4th Cir. Oct. 2, 2018).

plaintiff's registrations imposed upon the counterclaim defendant the burden of proving the invalidity of the counterclaim plaintiff's claimed marks, the court rejected the proposition that the registrations of those marks necessarily created a factual dispute on the issue. Moreover, it credited the counterclaim defendant's showing of genericness, which included "compelling evidence" in the form of "use of the [m]arks on other websites and in newspapers by third parties to describe the services offered and not the source of the services,"⁷¹¹ "undisputed evidence show[ing] that the previous owners of the [m]arks used 'we buy houses' as a generic description of the services they offered, not to identify the source of the services,"⁷¹² and, finally, widespread generic use by competitors.⁷¹³ "In sum," the court found as a matter of law, "this undisputed record evidence more than rebuts the presumption stemming from the PTO's determination that the [m]arks are not generic."⁷¹⁴

Likewise, a rare example of an opinion from a state appellate panel reaching a conclusion also apparently at odds with the Fourth Circuit's treatment of the issue came from the Appeals Court of Massachusetts.⁷¹⁵ The claimed mark at issue was "OrderMyOil.com," which the plaintiff used in connection with the delivery of home heating oil. The defendant successfully pursued the dismissal of the plaintiff's complaint for failure to state a claim, and its success continued on appeal. Conceding the genericness of "OrderOil," the plaintiff argued that the incorporation of "My" into its claimed mark rendered the resulting combination descriptive. The court was unmoved, and it concluded without extended analysis that the trial court properly had granted the defendant's motion to dismiss: "the name OrderMyOil.com 'identifies a key aspect of [the plaintiff's] services, i.e., the [service provided on the website]' and therefore it 'is generic for the services themselves.'"⁷¹⁶

Findings of genericness were not limited to marks in the form of domain names. For example, an Alabama federal district court sided with the defendants in a case turning in part on the validity of the plaintiff's claimed "BAK-12" mark for mobile aircraft arresting systems.⁷¹⁷ Two bases for that conclusion were the defendants' showings that the United States Air Force had originally coined the

⁷¹¹ *Id.* at 791.

⁷¹² *Id.* at 792.

⁷¹³ *Id.* at 793. The court observed of this consideration that "the mark owner's own use of a trademarked phrase to refer to the nature or class of services to which the mark applies is strong evidence that the [m]arks are generic." *Id.*

⁷¹⁴ *Id.*

⁷¹⁵ See *United Oil Heat, Inc. v. M.J. Meehan Excavating, Inc.*, 129 N.E.3d 856 (Mass. Ct. App. 2019).

⁷¹⁶ *Id.* at 858 (alterations in original) (quoting *In re Tires, Tires, Tires, Inc.*, 94 U.S.P.Q.2d 1153, 1157 (T.T.A.B. 2009)).

⁷¹⁷ See *Engineered Arresting Sys. Corp. v. Atech, Inc.*, 356 F. Supp. 3d 1323 (N.D. Ala. 2018).

term and had used it generically. Another was the court's acceptance of the defendants' argument that "[the plaintiff] itself has used BAK-12 generically and differently than other (uncontested) marks."⁷¹⁸ The court therefore granted the defendants' motion for summary judgment while observing that "[a]lthough [the plaintiff] was the only manufacturer of the BAK-12 for decades and evidence demonstrates that USAF and PAF thought as such, the term 'BAK-12' is a generic USAF designation for the BAK-12 aircraft arresting system and is therefore incapable of trademark protection."⁷¹⁹

As always, some courts addressed genericness-based challenges to marks by rejecting them, even if the resulting opinions failed to indicate where else on the spectrum of distinctiveness the marks in question might properly fall.⁷²⁰ One was the Eighth Circuit, which entertained an appeal from a jury finding that the registered STURGIS BIKE WEEK mark for a variety of promotional goods associated with a large annual motorcycle rally in Sturgis, South Dakota, protectable.⁷²¹ The court's analysis began by noting the onerous standard of review faced by the defendants, namely, that "the defendants had the burden to prove [genericness], and the jury was generally entitled to reject their proof."⁷²² This did not necessarily mean that the plaintiff's federal registrations would have carried the day under all circumstances, for "the evidence of a mark's genericness could be so overpowering that no reasonable jury could refuse to accept it."⁷²³ Nevertheless, the defendants' showing was fatally defective because it failed to take into account the nature of the goods at issue. As the court explained, "[i]f 'Sturgis Bike Week' is simply yet another common name for the rally, then the use of those words on a shirt might describe what the shirt is referring to

⁷¹⁸ *Id.* at 1338.

⁷¹⁹ *Id.* at 1342.

⁷²⁰ *See, e.g.,* A.V.E.L.A., Inc. v. Estate of Marilyn Monroe, LLC, 364 F. Supp. 3d 291, 313 (S.D.N.Y. 2019) (granting counterclaim plaintiffs' motion for summary judgment with cursory explanation that counterclaim defendants had identified "no evidence to demonstrate that consumers consider Marilyn Monroe's signature or likeness to be a generic mark that refers to a class of products[, namely, t-shirts]"); SafeRack, LLC v. Bullard Co., 350 F. Supp. 3d 438, 447, 454 (D.S.C. 2018) (rejecting defendant's claim that plaintiff's registered orange color was generic for "safe access and loading units" in cursory discussion of issue but noting that "[the plaintiff] has . . . submitted undisputed testimony from consumers that its use of orange to the purchasing public indicates the company rather than the class of product"), *report and recommendation adopted*, No. 2:17-cv-1613-RMG, 2019 WL 460699 (D.S.C. Feb. 5, 2019); Denali Real Estate, LLC v. Denali Custom Builders, Inc., 926 N.W.2d 610, 625 (Neb. 2019) (affirming, without extended discussion, trial court's finding that plaintiff's DENALI CONSTRUCTION and DENALI HOMES trade names were not generic for residential construction services).

⁷²¹ *See* Sturgis Motorcycle Rally, Inc. v. Rushmore Photo & Gifts, Inc., 908 F.3d 313 (8th Cir. 2018), *on remand*, 129 U.S.P.Q.2d 1392 (D.S.D. 2019).

⁷²² *Id.* at 335-36.

⁷²³ *Id.* at 337.

or commemorating, but it would not turn the words into the name of ‘the genus of which the [shirt] is a species.’”⁷²⁴

An Illinois federal district court went further still in holding that no reasonable jury could find the mark before it was generic.⁷²⁵ That mark was UGG for sheepskin boots, and the challenge to its validity was grounded primarily in its allegedly generic status in Australia. The defendants accused of infringing the mark introduced testimony from “[f]our Australian boot-suppliers . . . about their experiences selling sheepskin boots to U.S. customers,” especially through surf stores, and their belief the mark was generic.⁷²⁶ The suppliers’ testimony was consistent with that of an owner of two Jacksonville, Florida-based surf stores, who had, approximately a decade before the date of first use of the mark by the plaintiff’s predecessor, imported and sold the goods in question while under the impression that UGG was generic.⁷²⁷ Beyond these showings, the defendants adduced “a few” advertisements using the mark generically and an expert report from an Australian intellectual property law professor “regarding the legal status of ugg in Australia.”⁷²⁸

The court declined to allow perceptions of Australian consumers to create a factual dispute concerning the mark’s distinctiveness in the United States. It held:

Although evidence of how Australians used the word ugg could be relevant to consumer perceptions in the U.S., generic usage in Australia is not enough on its own to infer generic meaning in the United States. First, the doctrine is not a perfect fit for English to English, and is generally used to analyze non-English terms used in the American marketplace. Second, as applied here, the doctrine is simply an expression of the prohibition on allowing a trademark to monopolize a generic term. [The defendants have] evidence that ugg is generic in Australia, but there is no evidence that Americans familiar with Australian usage (or Australian visitors to the United States) would be misled into thinking that there is only one brand of ugg-style sheepskin boots available in this country. [The defendants] needed to come

⁷²⁴ *Id.* (alteration in original) (quoting *ZW USA, Inc. v. PWD Sys., LLC*, 889 F.3d 441, 448 (8th Cir. 2018)).

⁷²⁵ *See Deckers Outdoor Corp. v. Australian Leather Pty. Ltd.*, 340 F. Supp. 3d 706 (N.D. Ill. 2018).

⁷²⁶ *Id.* at 712.

⁷²⁷ *Id.* at 713.

⁷²⁸ *Id.* at 716.

The defendants additionally filed “a declaration and exhibits submitted during an Australian Trade Marks Office proceeding,” which purported to include “Australian telephone books, advertisements, and dictionaries using the term ugg,” but the court declined to consider those materials as unauthenticated hearsay. *Id.* at 715.

forward with some evidence that would allow a jury to conclude that the term *ugg* has a generic meaning to buyers in the United States; [their] Australian and surf-shop evidence does not suffice.⁷²⁹

Beyond dismissing the defendants' evidence, the court credited various showings by the plaintiff that its mark was valid. Those included the results of surveys employing undisclosed methodologies that putatively documented recognition of the mark as a brand among 58 percent of respondents in 2004, among 89 percent of respondents in 2001, and among 98 percent of respondents in 2017.⁷³⁰ They also included expert reports from a linguistics professor who "searched dictionaries and databases—including the Corpus of Contemporary American English, Google Books, Lexis-Nexis Academic, and the Newspaper Archive—for two relevant time periods (1970–80 and 2009–15) for uses of the word *ugg*” but failed to turn up any generic ones⁷³¹ and from a footwear historian who opined that “neither the word *ugg*, nor any variation of that spelling, was used ‘as a generic term by the general consuming public or the footwear trade in the U.S.’”⁷³² Finally, the court found, “[t]he *Complete Footwear Dictionary*, which identifies 110 types of boots and has been described as the “most widely used and authoritative general book on the subject of footwear,” does not mention *uggs*.”⁷³³ Under these circumstances, “[e]ven assuming the term is generic in Australia, no reasonable jury could conclude that it is generic in the United States.”⁷³⁴

Another failed claim of genericness, at least for purposes of a defense motion for summary judgment, came in a dispute between two providers of cleaning services for attics and crawl spaces.⁷³⁵ The disputed mark was CLEAN CRAWLS, five iterations of which the plaintiff had registered on the Principal Register with disclaimers of “clean.” The defendant’s showing of genericness relied heavily on dictionary definitions of “clean” and “crawl space,” as well as evidence of generic uses of the latter words in popular media. The court was unconvinced, holding that “consideration of the words only as separate entities violates the anti-dissection rule.”⁷³⁶ Moreover:

⁷²⁹ *Id.* at 715-16 (citations omitted).

⁷³⁰ *Id.* at 714.

⁷³¹ *Id.*

⁷³² *Id.*

⁷³³ *Id.* at 715.

⁷³⁴ *Id.* at 716.

⁷³⁵ *See Clean Crawl, Inc. v. Crawl Space Cleaning Pros, Inc.*, 364 F. Supp. 3d 1194 (W.D. Wash. 2019).

⁷³⁶ *Id.* at 1206.

While the term “crawl space” may well be widely understood by the public, and ‘crawl space cleaning’ could arguably be “identified with all such goods or services, regardless of their suppliers,” making it “generic and so not a valid mark,” the Court finds that a reasonable juror could conclude some element of imagination is needed to understand the CLEAN CRAWLS mark.⁷³⁷

Finally, the court rejected the defendant’s argument that use of the words “clean crawls” was competitively necessary in the parties’ industry, citing both the disclaimer in the plaintiff’s registrations and the existence of four third-party competitors that advertised their services in a manner less confusing than the defendant. There thus was a material dispute over whether the plaintiff’s mark was generic or, alternatively, suggestive.⁷³⁸

(ii) Descriptive Marks

“A descriptive mark conveys information about the associated product or service,”⁷³⁹ and a number of marks qualified as descriptive over the past year without extended analyses.⁷⁴⁰ For example, in an application of this definition, the Fifth Circuit determined as a matter of law on appeal that the READ A MILLION WORDS mark was merely descriptive of a literacy program and associated promotional goods. According to the court, “[the mark] states the goal of [the plaintiff’s] campaign in plain English; no imagination is needed to understand what the mark is meant to convey.”⁷⁴¹

The Seventh Circuit also reached a determination of descriptiveness as a matter of law, albeit in a case in which it affirmed the same conclusion by the district court below.⁷⁴² The mark at issue was CAPSULE, which the plaintiff had registered for cellphone cases. Seeking to bolster the conceptual strength of its mark for purposes of the likelihood-of-confusion inquiry, the plaintiff advanced a claim of inherent distinctiveness. Acknowledging that distinctiveness was a question of fact, the appellate court nevertheless affirmed the district court’s resolution of it on the defendant’s motion for summary judgment. It did so

⁷³⁷ *Id.* (citations omitted).

⁷³⁸ *Id.* at 1207.

⁷³⁹ *Springboards to Educ., Inc. v. Hous. Indep. Sch. Dist.*, 912 F.3d 805, 814 (5th Cir. 2019), *as revised* (Jan. 29, 2019), *and as revised* (Feb. 14, 2019).

⁷⁴⁰ *See, e.g., Safeway Transit LLC v. Disc. Party Bus, Inc.*, 334 F. Supp. 3d 995, 1004 n.6 (D. Minn. 2018) (referencing parties’ agreement that RENT MY PARTY BUS and 952 LIMO BUS marks were descriptive of party bus services), *appeal docketed*, No. 18-2990 (8th Cir. Sept. 17, 2018).

⁷⁴¹ *Springboards to Educ.*, 912 F.3d at 814.

⁷⁴² *See Uncommon, LLC v. Spigen, Inc.*, 926 F.3d 409 (7th Cir. 2019).

based on undisputed evidence and testimony of at least ten third-party users of the same mark for goods competitive with those of the plaintiff; although the plaintiff sought to explain away that usage as “its competitors’ freeloading on [the plaintiff’s] good reputation with consumers,” the court concluded that “[t]here is no evidence of that good reputation, let alone evidence of copying”⁷⁴³ Two additional considerations cited by the court as establishing the mark’s descriptiveness were the lack of imagination needed to determine the nature of the goods sold under the mark⁷⁴⁴ and dictionary definitions favorable to the defendant’s position.⁷⁴⁵ The plaintiff’s showings that the USPTO had allowed registrations of some (but by no means all) “capsule” marks without requiring disclaimers of the word and that only 14 percent of respondents to a survey had associated the word with cellphone-related goods failed to create a factual dispute on the issue.⁷⁴⁶

Not surprisingly, a New York federal district court hearing a preliminary injunction motion by the Museum of Modern Art aimed at protecting that institution’s MoMA mark also reached a finding of descriptiveness, at least with respect to the Museum’s flagship services.⁷⁴⁷ With respect to them, the court found that “[t]he Museum’s mark is descriptive because the acronym ‘MoMA’ stands for ‘Museum of Modern Art.’ The mark plainly communicates that MoMA is a museum that displays modern art.”⁷⁴⁸ As a consequence, the Museum could protect the mark only upon a showing of acquired distinctiveness.

Likewise, and also on a motion for a preliminary injunction, a different court found the COMPHY, COMPHY COMPANY, and COMPHY CO. marks merely descriptive for linen and bedding provided to luxury spas.⁷⁴⁹ To reach that conclusion, the court applied the so-called “imagination test,” which, it explained, “does not ask what information about the product *could* be derived from a mark, but rather whether a mental leap is *required* to understand the mark’s relationship to the product.”⁷⁵⁰ Although observing that “[d]etermining whether a mark is descriptive or suggestive is

⁷⁴³ *Id.* at 422.

⁷⁴⁴ *Id.*

⁷⁴⁵ On this issue, the court faulted the district court for relying too heavily on the defendant’s proffered definitions, but it also held that “there is no prohibition on using dictionaries as a piece of the puzzle.” *Id.* at 423.

⁷⁴⁶ *Id.*

⁷⁴⁷ *See* Museum of Modern Art v. MOMACHA IP LLC, 339 F. Supp. 3d 361 (S.D.N.Y. 2018).

⁷⁴⁸ *Id.* at 374.

⁷⁴⁹ *See* Comphy Co. v. Amazon.com, Inc., 371 F. Supp. 3d 914 (W.D. Wash. 2019).

⁷⁵⁰ *Id.* at 924 (quoting Zobmondo Entm’t, LLC v. Falls Media, LLC, 602 F.3d 1108, 1116 (9th Cir. 2010)).

difficult and is not an exact science,⁷⁵¹ it ultimately found that “Plaintiff’s COMPHY mark appears more descriptive than suggestive. As it relates to sheets and bedding, COMPHY is descriptive. It describes a quality of the product—that the bedding is comfortable.”⁷⁵²

Marks with strong geographic connotations typically also fall within the descriptiveness category. Thus, for example, one Alabama-based plaintiff seeking to protect its claimed ONE TEN and ONE TEN STUDENT LIVING marks for an off-campus student housing facility was unable to do so in the absence of a showing of acquired distinctiveness.⁷⁵³ As the court explained, “[the plaintiff’s] One Ten Student Living facility is located at 110 Long Street, Mobile, Alabama, 36608.”⁷⁵⁴ This meant the mark was geographically descriptive and therefore not inherently distinctive.

A Louisiana federal district court applied a variation on this general rule.⁷⁵⁵ The mark in question was ST. ROCH MARKET for a public marketplace and food hall located on St. Roch Avenue in New Orleans. The court had no difficulty finding that:

[U]se of the mark in New Orleans is geographically descriptive. St. Roch is the name of the avenue on which the market is located, and is one name for the neighborhood in which it is situated. The geographic element of the mark is clearly connected to the services provided by St. Roch Market in New Orleans. Thus, the mark identifies the place where the services are provided. This association between place and services makes St. Roch Market geographically descriptive for consumers in the New Orleans area.⁷⁵⁶

At the same time, however, it also found that “[p]otential consumers in Chicago, Nashville, and other cities far afield likely would not make the same association. St. Roch—unlike, say, the French Quarter—is not a place name that is generally recognizable by the American public.”⁷⁵⁷ “Thus,” the court concluded, “the use of the mark outside the New Orleans area is inherently distinctive rather than geographically descriptive.”⁷⁵⁸

Finally, a New York federal district court confirmed and applied the traditional rule that surnames are properly treated as

⁷⁵¹ *Id.* at 923.

⁷⁵² *Id.* at 924.

⁷⁵³ *See* ZP No. 314, LLC v. ILM Capital, LLC, 335 F. Supp. 3d 1242 (S.D. Ala. 2018).

⁷⁵⁴ *Id.* at 1255.

⁷⁵⁵ *See* Helpful Hound, L.L.C. v. New Orleans Bldg. Corp., 331 F. Supp. 3d 581 (E.D. La. 2018).

⁷⁵⁶ *Id.* at 593.

⁷⁵⁷ *Id.* at 595-94.

⁷⁵⁸ *Id.* at 594.

descriptive marks.⁷⁵⁹ It did so in a case brought by a law firm operating under the MCALLISTER OLIVARIUS service mark, which the defendant argued in a motion to dismiss was unprotectable. In denying the motion, the court held that “[m]arks that are ‘primarily merely surnames’ constitute a specific subcategory of descriptive marks, in that they describe the fact that the named individual is affiliated with the firm. Therefore, ‘McAllister Olivarius,’ as a descriptive mark, is protectable . . . if it has acquired secondary meaning.”⁷⁶⁰

(iii) Suggestive Marks

“A suggestive mark ‘suggests, but does not describe, an attribute of the good; it requires the consumer to exercise his imagination to apply the trademark to the good,’”⁷⁶¹ and applications of this and substantively identical standards led to findings of suggestive marks in several cases.⁷⁶² For example, the Fifth Circuit reached such a finding in a case in which the plaintiff, an education-services company specializing in promoting literacy among low-income and English-as-a-second-language students, used the MILLION DOLLAR READER, MILLIONAIRE READER, and MILLIONAIRE’S READING CLUB marks in connection with its services.⁷⁶³ As the court explained of the marks’ inherent distinctiveness, “[i]t requires some imagination to equate the traditional concept of a millionaire with a student who has read a million words. But the terms used in the marks are nevertheless related to [the plaintiff’s] products: items given to students who read one million words in a monetary-themed literacy program.”⁷⁶⁴

The Sixth Circuit also classified a mark as suggestive, albeit in an opinion in which the court also flirted with a finding that the mark was fanciful.⁷⁶⁵ Addressing the claimed PERCHVILLE mark for an annual festival, “replete with a polar bear swim and a fishing contest,”⁷⁶⁶ as well as licensed apparel associated with the festival,

⁷⁵⁹ See *McAllister Olivarius v. Mermel*, 298 F. Supp. 3d 661 (S.D.N.Y. 2018).

⁷⁶⁰ *Id.* at 670.

⁷⁶¹ *Springboards to Educ., Inc. v. Hous. Indep. Sch. Dist.*, 912 F.3d 805, 814 (5th Cir. 2019) (quoting *Xtreme Lashes, LLC v. Xtended Beauty, Inc.*, 576 F.3d 221, 227 (5th Cir. 2009)), *as revised* (Jan. 29, 2019), *and as revised* (Feb. 14, 2019).

⁷⁶² See, e.g., *Kohler Co. v. Bold Int’l FZCO*, 127 U.S.P.Q.2d 1459, 1469 (E.D.N.Y. 2018) (finding, in context of unopposed motion for default judgment, that plaintiff’s THE BOLD LOOK OF KOHLER, BOLD.POWER., BOLD.PERFORMANCE., BOLD.CONSERVATION., BOLD.STYLE., BOLD.DURABILITY., BOLD.EXPERIENCE., and LIVE BOLD marks suggestive of kitchen and bath fixtures), *report and recommendation adopted in relevant part*, No. 17-cv-4233 (LDH) (RLM), 2018 WL 4804655 (E.D.N.Y. Oct. 4, 2018).

⁷⁶³ *Springboards to Educ.*, 912 F.3d at 810.

⁷⁶⁴ *Id.* at 815.

⁷⁶⁵ See *Ausable River Trading Post, LLC v. Dovetail Sols., Inc.*, 902 F.3d 567 (6th Cir. 2018).

⁷⁶⁶ *Id.* at 569.

the court initially observed, “Perchville’ bears a classic feature of a fanciful mark. Someone made up the name ‘for the sole purpose of serving as a trademark.’”⁷⁶⁷ Nevertheless, it then backtracked to a more defensible conclusion: “Unlike a typical fanciful word, Perchville is not nonsense and so also qualifies as a suggestive mark. The name ‘Perchville’ consists of a mash-up of two otherwise real expressions: the fish ‘perch’ plus the suffix ‘-ville,’ used to signify ‘the names of fictitious places or concepts denoting a particular quality.’”⁷⁶⁸

An Eleventh Circuit opinion similarly tackled a mark potentially falling into two categories on the spectrum of distinctiveness but resolved the issue with greater success.⁷⁶⁹ The mark in question was GORILLA PLAYSETS for children’s outdoor playground equipment, which the district court had improbably found “descriptive or suggestive.”⁷⁷⁰ On the defendant’s appeal from a finding of liability, the court placed the mark squarely into the latter category: “The products [the plaintiff] sells under the mark are, of course, not designed for or used by gorillas. At a minimum, the connection between the mark and the product requires some imagination.”⁷⁷¹ The mark therefore was inherently distinctive.

A Nevada federal district court reached a finding of mark suggestiveness in the context of a preliminary injunction motion.⁷⁷² That motion was brought by the owner of several casinos and hotels, two of which operated under the SANDS and JINSHA marks. As the court summarized the plaintiff’s argument regarding the marks’ distinctiveness, “Plaintiff contend[s] [the marks] are arbitrary because “there is no intrinsic connection to its hotel or casino services.”⁷⁷³ The court agreed, finding that “the ‘SANDS’ and ‘JINSHA’ marks are strong as they do not appear to describe . . . Plaintiff’s underlying hotel and casino services.”⁷⁷⁴

Finally, a somewhat shakier finding of suggestiveness came in a dispute between providers of competing retail banking services.⁷⁷⁵ The plaintiff’s mark was CENTRAL BANK & TRUST, which the defendants not surprisingly attacked as descriptive. The court declined to credit that attack, instead finding it “highly unlikely that

⁷⁶⁷ *Id.* at 571 (quoting J. Thomas McCarthy, *McCarthy on Trademarks and Unfair Competition* § 11:5 (5th ed. 2018)).

⁷⁶⁸ *Id.* (quoting *New Fowler’s Modern English Usage* 826 (R.W. Burchfield ed., 3d rev. ed. 1998)).

⁷⁶⁹ *See PlayNation Play Sys., Inc. v. Vex Corp.*, 924 F.3d 1159 (11th Cir. 2019).

⁷⁷⁰ *Id.* at 1165.

⁷⁷¹ *Id.* at 1165-66.

⁷⁷² *See Las Vegas Sands Corp. v. Fan Yu Ming*, 360 F. Supp. 3d 1072 (D. Nev. 2019).

⁷⁷³ *Id.* at 1077.

⁷⁷⁴ *Id.*

⁷⁷⁵ *See Cent. Bancorp, Inc. v. Cent. Banccompany, Inc.*, 385 F. Supp. 3d 1122 (D. Colo. 2019).

a normal banking consumer would see the title “Central Bank & Trust” and think of something like the Federal Reserve. Rather, “Central” potentially connotes several things about, for example, geography, convenience, and perhaps even importance and stability. It is thus more suggestive than descriptive.”⁷⁷⁶

(iv) Arbitrary Marks

“Arbitrary . . . marks have no relation to the product or service” associated with them.⁷⁷⁷ Although that definition is easy enough to state, actual findings of arbitrariness were, as usual, few and far between. One, however, was reached by a New York federal district court, which concluded that the HYP mark—intended as a derivation of “hypnotic” and varyingly pronounced “hip” or “hype”—was inherently distinctive for socks and athletic bras; that conclusion was qualified by the court’s finding in the alternative that the mark might well be fanciful instead.⁷⁷⁸ And another court in the same district concluded that, although the Museum of Modern Art’s MoMA mark was descriptive when used for museum services, that did not mean it could not qualify as inherently distinctive in other contexts: As the court found, “[t]he Museum’s mark is . . . arbitrary in connection with the Museum’s sale of food and beverages, as the acronym ‘MoMA’ does not communicate any information about the Museum’s cafés or restaurants.”⁷⁷⁹ Finally, a Florida federal district court found on a preliminary injunction motion that the SANDBAR BAR & GRILL mark was arbitrary for a sports bar and restaurant, even if the generic nature of the mark’s last two words prevented them from falling into that category on a standalone basis.⁷⁸⁰

(v) Coined or Fanciful Marks

If findings of arbitrariness were rare, findings that marks were coined or fanciful were even more so. Indeed, only one reported opinion clearly reached such a finding in an action to protect the SABACC mark for a card game.⁷⁸¹ Even that example, however, transpired in the context of the court’s denial of a motion to dismiss

⁷⁷⁶ *Id.* at 1138.

⁷⁷⁷ *Springboards to Educ., Inc. v. Hous. Indep. Sch. Dist.*, 912 F.3d 805, 814 (5th Cir. 2019), *as revised* (Jan. 29, 2019), *and as revised* (Feb. 14, 2019).

⁷⁷⁸ *See Hypnotic Hats, Ltd. v. Wintermantel Enters.*, 335 F. Supp. 3d 566, 585 (S.D.N.Y. 2018).

⁷⁷⁹ *Museum of Modern Art v. MOMACHA IP LLC*, 339 F. Supp. 3d 361, 374 (S.D.N.Y. 2018).

⁷⁸⁰ *See Canes Bar & Grill of S. Fla., Inc. v. Sandbar Bay, LLC*, 343 F. Supp. 3d 1236, 1243 (S.D. Fla. 2018).

⁷⁸¹ *See Lucasfilm Ltd. v. Ren Ventures Ltd.*, 126 U.S.P.Q.2d 1515, 1516 (N.D. Cal. 2018).

the plaintiffs' complaint for failure to state a claim, rather than an actual finding based on a well-developed record.

(b) Determining the Inherent Distinctiveness of Trade Dress and Nontraditional Marks

The most comprehensive examination of the potential inherent distinctiveness of packaging trade dress arose from a dispute between competitors in the market for protein pancake mixes in which the plaintiff sought to protect the appearances of the following boxes:⁷⁸²



Consistent with Tenth Circuit authority on the issue,⁷⁸³ the Utah federal district court hearing the case initially invoked the test for inherent distinctiveness originally set out in *Seabrook Foods, Inc. v. Bar-Well Foods Ltd.*,⁷⁸⁴ which takes into account whether the trade dress at issue is: (1) “a common basic shape or design”;⁷⁸⁵ (2) “unique or unusual in a particular field”;⁷⁸⁶ and (3) “a mere refinement of a commonly-adopted and well-known form of ornamentation for a particular class of goods viewed by the public as a dress or ornamentation for the goods.”⁷⁸⁷

⁷⁸² Kodiak Cakes LLC v. Cont'l Mills, Inc., 358 F. Supp. 3d 1219, 1225 (D. Utah 2019).

⁷⁸³ See *Forney Indus. v. Daco of Mo., Inc.*, 835 F.3d 1238, 1245 n.2 (10th Cir. 2016).

⁷⁸⁴ 568 F.2d 1342 (C.C.P.A. 1977).

⁷⁸⁵ *Id.* at 1344.

⁷⁸⁶ *Id.*

⁷⁸⁷ *Id.*

Its ultimate finding of inherent distinctiveness, however, rested on a different analysis, one more commonly used for verbal marks. Although the defendants sought to demonstrate the packages' *lack* of inherent distinctiveness by proffering third-party packages also featuring "a kraft-type box and/or a dark border offset by a light or tan background,"⁷⁸⁸ the court dismissed that showing because "viewed in its entirety, Plaintiff's trade dress is visually distinct from each of its competitors."⁷⁸⁹ It then concluded that "'the tone and layout of the colors, the style and size of the lettering, and, . . . the overall appearance of the [package's] labeling' were 'selected from an almost limitless supply of patterns, colors and designs' and are accordingly 'undeniably arbitrary.'"⁷⁹⁰

The inherent distinctiveness of packaging came into play in another case as well.⁷⁹¹ When a lollipop manufacturer sought to protect the appearance of the following packaging in which it sold its goods, it faced a threshold inquiry into whether its claimed trade dress was inherently distinctive:⁷⁹²



Despite the Supreme Court's favorable references to packages as potentially inherently distinctive brand signals in *Wal-Mart Stores, Inc. v. Samara Bros.*,⁷⁹³ the court took its guidance from *Qualitex*

⁷⁸⁸ *Kodiak Cakes*, 358 F. Supp. 3d at 1229.

⁷⁸⁹ *Id.*

⁷⁹⁰ *Id.* (alterations in original) (quoting *Paddington Corp. v. Attiki Imps. & Distribs., Inc.*, 996 F.2d 577, 584 (2d Cir. 1993)).

⁷⁹¹ See *Spangler Candy Co. v. Tootsie Roll Indus.*, 372 F. Supp. 3d 588 (N.D. Ohio), *appeal dismissed*, No. 19-3227, 2019 WL 2564576 (6th Cir. May 10, 2019).

⁷⁹² *Id.* at 594.

⁷⁹³ 529 U.S. 205 (2000). In that case, the Court observed:

[T]he very purpose of attaching a particular word to a product, or encasing it in a distinctive packaging, is most often to identify the source of the product. Although the words and packaging can serve subsidiary functions . . . , their

Co. v. Jacobson Products Co.,⁷⁹⁴ in which the Court suggested that individual colors can never be inherently distinctive.⁷⁹⁵ From that starting point, it concluded:

[T]he elements cited [by the plaintiff as comprising its trade dress] are not distinctive to [its] packaging. Many candies on the market are packaged in a red bag with white brand lettering, a display window, and a violator indicating the product count that is sometimes yellow, blue, or oval-shaped. As such, the . . . trade dress is not inherently distinctive.⁷⁹⁶

(c) *Acquired Distinctiveness*

(i) **Opinions Finding Acquired Distinctiveness**

Section 2(f) of the Act provides that, in the registration context, “[t]he Director may accept as prima facie evidence that the mark has become distinctive . . . proof of substantially exclusive and continuous use thereof as a mark by the applicant in commerce for the five years before the date on which the claim of distinctiveness is made.”⁷⁹⁷ On its face, Section 2(f) has no applicability to determinations of acquired distinctiveness in actions to protect marks lacking inherent distinctiveness, but that has proven no obstacle to some plaintiffs invoking the statute. An example of that phenomenon came in a case in which the plaintiffs demonstrated to the court’s satisfaction that they had enjoyed the substantially exclusive use of two of their claimed unregistered marks for seven years before trial and the substantially exclusive use of another for six years.⁷⁹⁸ The court noted of the plaintiffs’ showing that “such use is . . . ‘a strong factor in favor of secondary meaning’ underlying an infringement determination.”⁷⁹⁹ That was not the extent of the plaintiffs’ evidentiary proffer on the subject, however; instead, the court found convincing the plaintiffs’ investment of “thousands of

predominant function remains source identification. Consumers are therefore predisposed to regard those symbols as indication of the producer, which is why such symbols “almost automatically tell a customer that they refer to a brand,” and “immediately . . . signal a brand or a product ‘source.’”

Id. at 205, 212-13 (2000) (citations omitted) (quoting *Qualitex Co. v. Jacobson Prods. Co.*, 514 U.S. 159, 163, 115 S. Ct. 1300, 1303 (1995)).

⁷⁹⁴ 514 U.S. 159 (1995).

⁷⁹⁵ *Id.* at 162-63; *see also* *Wal-Mart Stores, Inc. v. Samara Bros.*, 529 U.S. 205, 211-12 (2000) (“Indeed, with respect to at least one category of mark—colors—we have held [in *Qualitex*] that no mark can ever be inherently distinctive. . . . We held that a color could be protected as a trademark, but only upon a showing of secondary meaning.”).

⁷⁹⁶ *Spangler Candy Co.*, 372 F. Supp. 3d at 601 (citation omitted) (footnote omitted).

⁷⁹⁷ 15 U.S.C. § 1052(f) (2018).

⁷⁹⁸ *See* *Safeway Transit LLC v. Disc. Party Bus, Inc.*, 334 F. Supp. 3d 995, 1005 (D. Minn. 2018), *appeal docketed*, No. 18-2990 (8th Cir. Sept. 17, 2018).

⁷⁹⁹ *Id.* (quoting *Stuart Hall Co. v. Ampad Corp.*, 51 F.3d 780, 789 (8th Cir. 1995)).

dollars” in promoting the marks through “thousands of printed fliers [sic]” and “Google, Facebook, third-party . . . websites, and print media,” the incorporation of the marks into domain names registered by the plaintiffs, and the marks’ display on a fleet of buses operated by the plaintiffs.⁸⁰⁰ Of perhaps equal importance, the court also credited “uncontroverted testimony about growing consumer engagement on Facebook and Twitter” with the plaintiffs’ business.⁸⁰¹ Although the court declined to accord weight to the plaintiffs’ allegations of intentional copying—in significant part because the plaintiffs had themselves copied the marks from the defendants, who were the marks’ original owners—the plaintiffs’ circumstantial evidence established the existence of acquired distinctiveness even in the absence of direct evidence.⁸⁰²

A Louisiana federal district court similarly reached a finding of acquired distinctiveness for the geographically descriptive ST. ROCH MARKET mark for a marketplace and food hall located in the St. Roch neighborhood of New Orleans after weighing the factors in the Fifth Circuit’s test for secondary meaning, namely:

- (1) length and manner of use of the mark or trade dress,
- (2) volume of sales, (3) amount and manner of advertising,
- (4) nature of use of the mark or trade dress in newspapers and magazines, (5) consumer-survey evidence, (6) direct consumer testimony, and (7) the defendant’s intent in copying the mark.⁸⁰³

The parties agreed the mark had been used “since the late 1800s” (under, the court found in another part of its opinion, the counterclaim plaintiffs’ authority).⁸⁰⁴ Aside from that consideration, the court found probative the counterclaim defendants’ express association of their use of the mark in Florida with the original New Orleans market.⁸⁰⁵ Largely on the basis of these showings, the court

⁸⁰⁰ *Id.* at 1005.

⁸⁰¹ *Id.*

⁸⁰² *Id.* at 1005-06.

⁸⁰³ *Helpful Hound, L.L.C. v. New Orleans Bldg. Corp.*, 331 F. Supp. 3d 581, 594 (E.D. La. 2018) (quoting *Viacom Int’l v. IJR Capital Invs., L.L.C.*, 891 F.3d 178, 190 (5th Cir. 2018)).

⁸⁰⁴ *Id.*

⁸⁰⁵ On this issue, the court noted from the preliminary injunction record that:

[A] screenshot of defendants’ website for its Miami location states that “St. Roch Market is a contemporary, multi-vendor food hall brand, hailing from New Orleans,” and that “[t]his popular New Orleans food hall has made its way down to Miami.” Another screenshot from the website gives a brief history of St. Roch Market in New Orleans. These deliberate associations suggest that defendants themselves believe the mark has “secondary meaning that could influence consumers, which further supports the conclusion that there is secondary meaning here.”

found on the counterclaim plaintiffs' preliminary injunction motion that "it is . . . substantially likely that [the counterclaim plaintiffs] will be able to establish secondary meaning of the mark in the New Orleans area."⁸⁰⁶

An application of the Sixth Circuit's factors for evaluating claims of acquired distinctiveness led an Ohio federal district court hearing a preliminary injunction motion to find that the non-inherently distinctive appearance of a lollipop bag qualified for protection against alleged copying by a competitor.⁸⁰⁷ Those factors were: "(1) direct consumer testimony, (2) consumer surveys, (3) exclusivity, length, and manner of use, (4) amount and manner of advertising, (5) amount of sales and number of customers, (6) established place in the market, and (7) proof of intentional copying."⁸⁰⁸ The plaintiff lacked direct evidence under the first two factors, and it similarly failed to submit circumstantial evidence in the form of "look-for" advertising,⁸⁰⁹ but the court found more convincing the plaintiff's use of its packaging for six years (and its use of elements of that packaging for twenty-three years) prior to the introduction of the defendant's packaging⁸¹⁰ and, most importantly, the defendant's intentional copying of the plaintiff's design.⁸¹¹

A motion for preliminary injunctive relief similarly led to a finding that the MoMA mark—an acronym for "Museum of Modern Art"—had acquired distinctiveness for its owner's museum services.⁸¹² The court began its analysis by observing that "[i]n determining whether a mark has acquired secondary meaning, courts have examined 'advertising expenditures, consumer studies linking the name to a source, unsolicited media coverage of the product, attempts to plagiarize the mark, and length and exclusivity of the mark's use.'"⁸¹³ It then found that the plaintiff's mark passed that test with flying colors. The plaintiff's use of the mark "for nearly 50 years" played a role in that finding, as did its long-standing ownership of registrations covering it.⁸¹⁴ In addition, "[t]he Museum

Id. at 595 (alteration in original) (footnotes omitted) (quoting *Bd. of Supervisors for La. State Univ. Agric. & Mech. Coll. v. Smack Apparel Co.*, 550 F.3d 465, 477 (5th Cir. 2008)).

⁸⁰⁶ *Id.*

⁸⁰⁷ See *Spangler Candy Co. v. Tootsie Roll Indus.*, 372 F. Supp. 3d 588 (N.D. Ohio), *appeal dismissed*, No. 19-3227, 2019 WL 2564576 (6th Cir. May 10, 2019).

⁸⁰⁸ *Id.* at 601 (quoting *Gen. Motors Corp. v. Lanard Toys, Inc.*, 468 F.3d 405, 418 (6th Cir. 2006)).

⁸⁰⁹ *Id.* at 602.

⁸¹⁰ *Id.* at 602 n.10.

⁸¹¹ *Id.* at 602-03.

⁸¹² See *Museum of Modern Art v. MOMACHA IP LLC*, 339 F. Supp. 3d 361 (S.D.N.Y. 2018).

⁸¹³ *Id.* at 374 (quoting *Thompson Medical Co. v. Pfizer Inc.*, 753 F.2d 208, 216 (2d Cir. 1985)).

⁸¹⁴ *Id.*

advertises and promotes its services under its mark in a variety of print and digital publications, such as The New York Times, The Wall Street Journal, The New Yorker, Art in America, Variety, Hollywood Reporter, WNET, New York Magazine, Vice, and Gothamist, [and] [t]he Museum has also received significant media coverage.”⁸¹⁵ Finally, the court found, “[the defendants’] use of a font and style highly similar to those of the Museum’s mark . . . constitutes an attempt to copy the Museum’s mark.”⁸¹⁶ Although the defendants introduced evidence of third-party uses of allegedly similar marks in connection with the sale of shoes and wine, that evidence did not weaken the plaintiff’s case because “shoes and wine are so remote from the products offered by the Museum and [the defendants] that there is little need for the Museum to attack those uses in order to protect the value of its distinctive mark”⁸¹⁷

(ii) Opinions Declining to Find Acquired Distinctiveness

The most extensive discussion of the concept of acquired distinctiveness over the past year came in an Eighth Circuit opinion that overturned a jury’s findings of validity for several registered and unregistered geographically descriptive marks based on the word “Sturgis,” a reference to Sturgis, South Dakota, the home of the world’s largest annual motorcycle rally.⁸¹⁸ The plaintiff was the successor in interest to Sturgis Area Chamber of Commerce, which chose to rely at trial on circumstantial evidence of the validity of its claimed marks, rather than direct evidence such as survey evidence or testimony from consumers. According to the court, the plaintiff’s showing rested on “two basic arguments” about the trademark status of “Sturgis”:

First, the mark identifies it as a distinct source of rally-related goods and services because it and the Chamber, its predecessor-in-interest, have been the mark’s continuous and substantially exclusive users in relation to the rally since July 1, 1987; and second, consumers associate the mark with the rally, and the rally is a service that [the Chamber] provides (or alternatively is a service the service-mark rights to which it has acquired) because the Chamber has “hosted” the rally since the 1940s and is today the rally’s “sole organizer, promoter and sponsor.”⁸¹⁹

⁸¹⁵ *Id.* at 374-75.

⁸¹⁶ *Id.* at 375.

⁸¹⁷ *Id.*

⁸¹⁸ See *Sturgis Motorcycle Rally, Inc. v. Rushmore Photo & Gifts, Inc.*, 908 F.3d 313 (8th Cir. 2018), *on remand*, 129 U.S.P.Q.2d 1392 (D.S.D. 2019).

⁸¹⁹ *Id.* at 324.

The court found the plaintiff's showing under either theory fatally defective, and, without apparent deference to the jury's view of the trial record, found as a matter of law on appeal that the marks at issue lacked distinctiveness. The court first targeted the documentary evidence of the pre-licensing-program use of "Sturgis" on a standalone basis by the plaintiff and its predecessor, of which the court remarked, "[the plaintiff] does not even attempt to explain how these seemingly descriptive uses of the word were actually uses of it as a mark, and we cannot see how that interpretation could be reasonable."⁸²⁰ It was equally unimpressed by the word's use of a component of other marks claimed by the plaintiff because they were equally descriptive.⁸²¹ The existence of a licensing program for the claimed mark did not assist the plaintiff's case, both because the third parties participating in it might have done so only because the profits went to support the city of Sturgis⁸²² and because of the large number—"perhaps hundreds"—of third-party users of "Sturgis" marks that did not so participate.⁸²³ That the plaintiff and its predecessor claimed to be the sole promoters of the rally, a claim the court deemed unsupported by the record,⁸²⁴ did not mandate a contrary result.

Other claims of acquired distinctiveness were so deficient that their proponents both lost on summary judgment and failed to secure relief on appeal.⁸²⁵ For example, in explaining the deficiencies in one unsuccessful plaintiff's case, the Seventh Circuit

⁸²⁰ *Id.* at 325.

⁸²¹ As the court explained, "[w]hen the word 'Sturgis' is simply being used as part of another mark that itself seeks to communicate an association with 'Sturgis' the rally and city, the word is clearly not being used as its own distinct mark." *Id.*

⁸²² *Id.* at 326.

⁸²³ *Id.* at 327.

⁸²⁴ On this issue, the court concluded that:

Even if we assumed that in the mid-1980s the Chamber became a clearinghouse of promotional information and materials about the rally, the jury . . . had no basis to find that it was the only entity promoting the rally. Even if it had been the only one, the record can only be read as indicating that the Chamber was simply promoting an event that others—many others—were putting on. The record does not suggest that the Chamber or [the plaintiff] ever displaced those other people and groups. The witnesses, when asked, uniformly denied that any single entity owns or produces the rally; their testimony univocally indicated that . . . the rally has always been made up of the different events that different groups put on. Coordinating with the City on when streets should be blocked off to traffic and how the City could best accommodate (and pay for) the sudden influx of rallygoers into the area does not, moreover, convert the Chamber into the organizer and sponsor of the rally.

Id. at 331.

⁸²⁵ *See, e.g.,* *Comite Fiestas De La Calle San Sebastian, Inc. v. Soto*, 925 F.3d 528, 534 (1st Cir. 2019) (holding, in cursory treatment of issue, that of the affidavit testimony proffered by plaintiff in response to defendants' motion for summary judgment "none even hints that the public associates [the claimed mark] with a single commercial source").

noted the “many ways to prove a secondary meaning or lack thereof: amount of advertising, sales volume, length and manner of use, or consumer testimony, for example.”⁸²⁶ Having relied almost exclusively on the prima facie evidence of validity attaching to a registration covering its mark, the plaintiff was not in a position to contest the defendant’s proffer of survey evidence purporting to show that: (1) only 6 percent of respondents were familiar with the plaintiff’s mark *as a mark*; (2) only 14 percent “could connect the mark to [the plaintiff’s goods]”; and (3) “barely any (less than one percent)” associated the claimed mark with the plaintiff.⁸²⁷ Summary judgment in the defendant’s favor therefore stood on appeal, even though “[w]e can . . . assume that the manner and length of use inures in [the plaintiff’s] favor.”⁸²⁸

At the trial court level, one plaintiff’s claim of acquired distinctiveness for the configuration of an air horn failed to survive a defense motion to dismiss.⁸²⁹ As a point of reference, the New York federal district court hearing the case noted that, under Second Circuit authority, “[f]actors that are relevant in determining secondary meaning include (1) advertising expenditures, (2) consumer studies linking the mark to a source, (3) unsolicited media coverage of the product, (4) sales success, (5) attempts to plagiarize the mark, and [] (6) length and exclusivity of the mark’s use.”⁸³⁰ Under those factors, the court concluded, “[t]he complaint is devoid of any factual allegations from which a finding of secondary meaning may reasonably be inferred.”⁸³¹ In particular, “Plaintiff pleads no factual allegations in support of any of [the relevant] factors Plaintiff’s conclusory allegations are insufficient to state a plausible claim for relief.”⁸³² The court therefore disposed of the plaintiff’s claims without the need for discovery.

Finally, more than one opinion drove home the point that, to qualify as protectable against alleged misconduct by a defendant, a descriptive mark must acquire distinctiveness prior to the inception of that misconduct.⁸³³ For example, the summary judgment record before an Alabama federal district court established that the plaintiff had secured registrations of its geographically descriptive

⁸²⁶ *Uncommon, LLC v. Spigen, Inc.*, 926 F.3d 409, 424 (7th Cir. 2019).

⁸²⁷ *Id.*

⁸²⁸ *Id.* at 425.

⁸²⁹ *See Wolo Mfg. Corp. v. ABC Corp.*, 349 F. Supp. 3d 176 (E.D.N.Y. 2018).

⁸³⁰ *Id.* at 206 (alterations in original) (quoting *Christian Louboutin S.A. v. Yves Saint Laurent Am. Holdings, Inc.*, 696 F.3d 206, 226 (2d Cir. 2012)).

⁸³¹ *Id.*

⁸³² *Id.*

⁸³³ *See, e.g., Can’t Live Without It, LLC v. ETS Express, Inc.*, 373 F. Supp. 3d 434, 442-43 (S.D.N.Y. 2018) (declining to order new trial on issue of acquired distinctiveness in significant part because much of plaintiff’s evidence postdated defendant’s introduction of allegedly infringing trade dress).

marks on July 25, 2017, and October 17, 2017, but also that the defendants had registered domain names based on those marks and engaged in other challenged activities before the registration dates.⁸³⁴ Weighing the plaintiff's claim of priority, the court applied the Eleventh Circuit's test for acquired distinctiveness, which mandated consideration of: (1) the length and manner of the marks' use; (2) the nature and extent of the plaintiff's advertising; (3) the plaintiff's efforts to promote a conscious connection in the plaintiff's mind between the mark and the plaintiff; and (4) the extent to which the public actually associated the mark with the plaintiff's services.⁸³⁵ The plaintiff's showing fared poorly under an application of each factor: (1) the plaintiff had used its claimed marks for only "some six to seven months" before the defendants' actions began;⁸³⁶ (2) the plaintiff's promotion of the marks had been "meager" in nature;⁸³⁷ (3) there was "little evidence" of any attempts by the plaintiff to cultivate acquired distinctiveness in the mark;⁸³⁸ and (4) the plaintiff had failed to adduce favorable survey evidence on the issue.⁸³⁹ "Thus," the court concluded, "[the plaintiff] has not met its heavy burden of establishing that the marks had acquired secondary meaning by [the dates of the defendants' actions]."⁸⁴⁰

(iii) Opinions Deferring Resolution of the Acquired-Distinctiveness Inquiry

Attacks on the sufficiency of plaintiffs' averments of acquired distinctiveness at the pleadings stage of actions fail more often than they succeed,⁸⁴¹ and an opinion from a Virginia federal district court did nothing to buck that pattern.⁸⁴² In denying a motion to dismiss for failure to state a claim, that court invoked Fourth Circuit authority to hold:

[F]actors . . . relevant to, though not dispositive of, the "secondary meaning" inquiry [include]: (1) advertising expenditures; (2) consumer studies linking the mark to a source; (3) sales success; (4) unsolicited media coverage of the

⁸³⁴ See ZP No. 314, LLC v. ILM Capital, LLC, 335 F. Supp. 3d 1242 (S.D. Ala. 2018).

⁸³⁵ *Id.* at 1257 n.11.

⁸³⁶ *Id.* at 1257.

⁸³⁷ *Id.* at 1258.

⁸³⁸ *Id.* at 1259.

⁸³⁹ *Id.*

⁸⁴⁰ *Id.*

⁸⁴¹ See, e.g., GeigTech E. Bay LLC v. Lutron Elecs. Co., 352 F. Supp. 3d 265, 282 (S.D.N.Y. 2018) (denying motion to dismiss because "Defendant's arguments regarding the qualitative nature of Plaintiff's advertising, its lack of consumer surveys, and questions regarding prior attempts to plagiarize are all evidentiary in nature and properly reviewed on motion for summary judgment").

⁸⁴² See Rothy's, Inc. v. JKM Techs., LLC, 360 F. Supp. 3d 373 (W.D. Va. 2018).

product; (5) attempts to plagiarize the mark; and (6) the length and exclusivity of the mark's use.⁸⁴³

Although acknowledging that “[p]roof of secondary meaning entails vigorous evidentiary requirements,”⁸⁴⁴ the court also held that “secondary meaning [is] factual in nature and typically ill-suited for a motion to dismiss.”⁸⁴⁵ Turning to the complaint, the court credited its averments of \$40 million in sales of the product design claimed by the plaintiff as trade dress, the design's receipt of “significant media attention from a variety of national and global media sources,” and intentional copying by the defendants.⁸⁴⁶ The defendants responded by emphasizing that the design had been on the market for less than three years, but the court held that “[w]hile it is true that length of time is one factor a court should consider when determining secondary meaning, it is neither exclusive nor dispositive.”⁸⁴⁷ It therefore denied the defendants' motion, although inviting them to revisit the subject in a motion for summary judgment.⁸⁴⁸

The same outcome transpired in an action brought by a law firm to vindicate the rights to a service mark consisting of two surnames.⁸⁴⁹ The court applied the usual rule that “[d]etermining whether a descriptive mark has acquired secondary meaning is a fact-intensive inquiry' that is 'ill-suited for resolution at the motion to dismiss stage.’”⁸⁵⁰ Reviewing the plaintiff's complaint, the court found it replete with allegations potentially supporting a finding of acquired distinctiveness, including its: (1) exclusive use of the mark for over two decades along with substantial advertising and marketing of its legal services through traditional media and the internet; (2) receipt of significant media coverage as a result of its work and reputation; and (3) significant traffic to the firm's social media account.⁸⁵¹ “Construed in the light most favorable to plaintiff,” the court concluded, “these allegations give rise to a reasonable possibility that the . . . mark has acquired secondary meaning and, accordingly, is protectable.”⁸⁵²

⁸⁴³ *Id.* at 387 (quoting *Perini Corp. v. Perini Constr., Inc.*, 915 F.2d 121, 125 (4th Cir. 1990)).

⁸⁴⁴ *Id.* (quoting *Perini Corp.*, 915 F.2d at 125).

⁸⁴⁵ *Id.* (alteration in original) (quoting *Stat Ltd. v. Beard Head, Inc.*, 60 F. Supp. 3d 634, 639 (E.D. Va. 2014)).

⁸⁴⁶ *Id.* at 388.

⁸⁴⁷ *Id.*

⁸⁴⁸ *Id.*

⁸⁴⁹ See *McAllister Olivarius v. Mermel*, 298 F. Supp. 3d 661 (S.D.N.Y. 2018).

⁸⁵⁰ *Id.* at 670 (quoting *A.V.E.L.A., Inc. v. Estate of Marilyn Monroe, LLC*, 131 F. Supp. 3d 196, 212 (S.D.N.Y. 2015)).

⁸⁵¹ *Id.*

⁸⁵² *Id.*

Refusals to resolve the acquired-distinctiveness inquiry also came on more developed evidentiary records. The Federal Circuit rarely applies its own law in infringement disputes, but it did so in an appeal from a determination by the International Trademark Commission that the configuration of a sneaker midsole had not acquired distinctiveness.⁸⁵³ The plaintiff had registered its design, but the court held that registration's prima facie evidence of validity did not apply to uses by the defendants beginning after the registration's issuance.⁸⁵⁴ With respect to those uses, the court required the plaintiff to demonstrate the design's distinctiveness under an application of a seven-factor test that mandated consideration of: (1) the degree and manner of the plaintiff's use; (2) the exclusivity of the use; (3) the length of the use; (4) the degree and manner of sales; (5) the effectiveness of the effort to generate acquired distinctiveness; (6) deliberate copying; and (7) actual association of the design by consumers with the plaintiff.⁸⁵⁵

The ITC had found the plaintiff's showing under these factors inadequate, but the court of appeals reversed. That outcome held in substantial part because of the ITC's reliance on third-party use of similar designs under the second of the seven factors. To do so, the court invoked Section 2(f) of the Act, which, the court held, meant the ITC had erred by considering use by third parties of similar designs pre-dating the relevant five-year period:

While section 2(f) cannot be read as limiting the inquiry to the five years before the relevant date, it can and should be read as suggesting that this period is the most relevant Consumers are more likely to remember and be impacted in their perceptions by third-party uses within five years and less likely with respect to older uses. . . .

Therefore, uses older than five years should only be considered relevant if there is evidence that such uses were likely to have impacted consumers' perceptions of the mark as of the relevant date.⁸⁵⁶

Beyond the ITC's mistake in considering third-party uses placed off limits by the court's reading of Section 2(f), the court held the ITC had further erred by failing to exclude those uses not substantially similar to the one the plaintiff sought to protect. The cumulative effect of these missteps by the agency produced a vacatur and remand.⁸⁵⁷

⁸⁵³ See *Converse, Inc. v. Int'l Trade Comm'n*, 909 F.3d 1110 (Fed. Cir. 2018).

⁸⁵⁴ *Id.* at 1118.

⁸⁵⁵ *Id.* at 1119.

⁸⁵⁶ *Converse*, 909 F.3d at 1121.

⁸⁵⁷ *Id.* at 1122.

A similar procedural statement occurred in an action to protect an alleged trade dress comprising the look and feel of the plaintiff's website.⁸⁵⁸ With respect to the plaintiff's claim of acquired distinctiveness, the court observed on the parties' cross-motions for summary judgment that "[t]here is little direct evidence of secondary meaning here."⁸⁵⁹ Nevertheless, it also found the existence of a factual dispute based on circumstantial evidence, which it defined as:

1) the length and manner of the use of the trade dress; 2) the nature and extent of advertising and promotion; 3) the efforts to promote a conscious connection between the public, the trade dress, and the source; 4) the products' established place in the market (possibly through continuous use in the market); and 5) proof of intentional copying.⁸⁶⁰

In particular, it credited the plaintiff's arguments that defendant's intentional copying of elements of the website⁸⁶¹ and that the presence of the plaintiff's arguably suggestive verbal mark on the site constituted "sufficient evidence to allow a jury to conclude that [the plaintiff's] website was distinctive."⁸⁶²

(d) Survey Evidence of Distinctiveness

The most consequential treatment of survey evidence came in the Fourth Circuit's opinion in *Booking.com B.V. v. United States Patent & Trademark Office*,⁸⁶³ which originated in the USPTO's refusal to register the BOOKING.COM mark for an online reservation service for travel, tours, and lodging and which led to the Supreme Court's acceptance of the case for review. Having appealed the Trademark Trial and Appeal Board's determination that its mark was generic and therefore unregistrable, the mark's owner commissioned a *Teflon* survey,⁸⁶⁴ the results of which it introduced into evidence before the district court. Those results indicated that a net 74.8 percent of respondents recognized

⁸⁵⁸ See *Smartling, Inc. v. Skawa Innovation Ltd.*, 358 F. Supp. 3d 124 (D. Mass. 2019).

⁸⁵⁹ *Id.* at 149.

⁸⁶⁰ *Id.* (quoting *Genesis Strategies, Inc. v. Pitney Bowes, Inc.*, 50 F. Supp. 3d 59, 67 (D. Mass. 2014), *on reconsideration in part*, No. 11-12270-TSH, 2014 WL 4292830 (D. Mass. Aug. 27, 2014)).

⁸⁶¹ *Id.* at 150 ("Although it may be that [the defendant] copied [the plaintiff's] website out of mere laziness, it would not be unreasonable for a jury to conclude that [the defendant] copied features of [the plaintiff's] website because they viewed is as distinctive and attractive to consumers.").

⁸⁶² *Id.*

⁸⁶³ 915 F.3d 171 (4th Cir.), *as amended* (Feb. 27, 2019), *cert. granted*, No. 19-46, 2019 WL 5850636 (U.S. Nov. 11, 2019).

⁸⁶⁴ See *E. I. DuPont de Nemours & Co. v. Yoshida Int'l, Inc.*, 393 F. Supp. 502, 525-527 (E.D.N.Y. 1975).

BOOKING.COM as a brand rather than a generic service, an outcome that led the district court to find that, at least in some contexts, the mark was descriptive, rather than generic.

On appeal, the USPTO questioned neither the validity nor the methodology of the survey, but it did argue the district court had erred in considering the survey at all, citing past Fourth Circuit authority to that effect, namely, *Hunt Masters, Inc. v. Landry's Seafood Restaurant, Inc.*⁸⁶⁵ The court rejected that contention, taking the opportunity to clarify its earlier treatment of the issue in a holding that merits reproduction at length:

[T]here are two ways in which terms may be classified as generic—“(1) where the term began life as a ‘coined term’” that had become generic through common usage, and “(2) where the term was commonly used prior to its association with the products at issue”—and that while consumer surveys are relevant to determining whether a term is generic in the former scenario, they are not in the latter. Contrary to the USPTO’s contention, *Hunt Masters* does not control where, as here, the district court determined based on the dearth of evidence in the record that the proposed mark was not commonly used. As such, the proposed mark does not fall within the category of terms for which survey evidence is irrelevant.⁸⁶⁶

“Accordingly,” the court concluded, “where, as here, the district court found that the survey was methodologically sound, the survey is strong evidence that the public does not understand BOOKING.COM to refer to the proposed mark’s generic meaning.”⁸⁶⁷

Defendants’ reliance on survey results produced differing outcomes. For example, the Seventh Circuit found convincing a distinctiveness survey purporting to document that “very few customers (six percent) were familiar with [the plaintiff’s claimed mark] as a brand name”⁸⁶⁸ That number was not the only unhelpful one for the plaintiff’s purposes; instead, “only slightly more (14 percent) could connect the mark to [the plaintiff’s goods] when prompted; and barely any (less than one percent) associated [the plaintiff’s claimed mark] with [the plaintiff].”⁸⁶⁹ “That evidence,” the Seventh Circuit observed, “led the district court to conclude that [the plaintiff’s mark] had no secondary meaning,”⁸⁷⁰

⁸⁶⁵ 240 F.3d 251 (4th Cir. 2001).

⁸⁶⁶ See *Booking.com*, 915 F.3d at 183 (quoting *Hunt Masters*, 240 F.3d at 254-55).

⁸⁶⁷ *Id.*

⁸⁶⁸ *Uncommon, LLC v. Spigen, Inc.*, 926 F.3d 409, 424 (7th Cir. 2019).

⁸⁶⁹ *Id.*

⁸⁷⁰ *Id.*

and the appellate court was disinclined to disagree with that disposition. The plaintiff feebly argued the survey results created a factual dispute because its claimed mark enjoyed a level of recognition equal to that of “a few other brands,” but the court reached the contrary conclusion “because none of the . . . comparators had much recognition either.”⁸⁷¹ For better or for worse, however, the court did not describe the survey’s methodology.

In contrast, the Federal Circuit viewed with a jaundiced judicial eye a defense survey proffered to demonstrate the absence of acquired distinctiveness attaching to a shoe midsole.⁸⁷² The court noted that the survey had been conducted between five and ten years after the defendants began their allegedly infringing uses. This limited the probative value of the results because only “[s]urveys that are conducted within five years of the relevant date may provide evidence as to secondary meaning”⁸⁷³ Thus, although the survey in question was relevant to the inquiry into whether the plaintiff’s trade dress had acquired distinctiveness at the time a registration covering it had issued two years earlier, the same was not necessarily true with respect to the dates of the defendants’ first uses. A vacatur and remand therefore was appropriate for consideration of the survey results under the proper framework.⁸⁷⁴

(3) Nonfunctionality

(a) Utilitarian Nonfunctionality

In *TrafFix Devices, Inc. v. Mktg. Displays, Inc.*,⁸⁷⁵ the Supreme Court came close to dismissing the evidentiary significance of competitive alternative designs in inquiries into whether particular

⁸⁷¹ *Id.* at 425.

⁸⁷² *See Converse, Inc. v. Int’l Trade Comm’n*, 909 F.3d 1110 (Fed. Cir. 2018).

⁸⁷³ *Id.* at 1123.

⁸⁷⁴ *Id.*

In taking this step, the court offered additional guidance to the International Trade Commission, in which the case had originated, on how to interpret the 21.5 percent net association rate reflected in the survey’s results. The ITC had found that rate evidence of a lack of acquired distinctiveness, but the court disapproved of that conclusion with the following observation:

We see no error in the conclusion that the survey does not establish secondary meaning, but we are unclear as to the ITC’s reasoning as to why the survey supports the opposite—a lack of secondary meaning. . . . In any remand where secondary meaning . . . is a relevant issue, the Board should analyze whether the survey shows lack of secondary meaning as of the date of registration. Unless the survey affirmatively shows a lack of secondary meaning, there is simply a lack of survey evidence of secondary meaning—which is a neutral factor favoring neither party.

Id.

⁸⁷⁵ 532 U.S. 23 (2001).

claimed trade dresses are functional or nonfunctional: According to the Court, “[w]here the design is functional . . . there is no need to proceed further to consider if there is a competitive necessity for the feature.”⁸⁷⁶ Since then, at least some courts have applied this rule to bar consideration, or discount the significance, of competing alternatives.⁸⁷⁷ Others, however, have proceeded as if the Court’s observation in *TrafFix Devices* never existed. Consistent with the increasing trend, more opinions fell into the latter category than the former over the past year.

One came from the Federal Circuit in an appeal arising from a proceeding before the International Trade Commission.⁸⁷⁸ Although that court has traditionally been hostile to claims of trade dress protection in product configurations, it rejected a claim of utilitarian functionality by a group of defendants accused of infringing the following federally registered trade dress:⁸⁷⁹

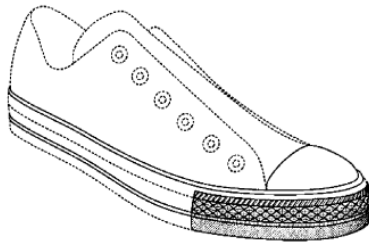

In an action for an order excluding confusingly similar imitations, the ITC found the design nonfunctional, and the appellate court affirmed. Its analysis was short and to the point: “Any functional benefit is derived from the presence of toe caps and bumpers generally, not the particular design of the . . . trademark, and there are numerous commercial alternatives to that design.”⁸⁸⁰

The Seventh Circuit also got into the act.⁸⁸¹ Like the Federal Circuit, that court has been unreceptive to claims of rights in nonverbal marks in recent years, but it affirmed a jury finding of nonfunctionality for the design of the following coffee press:⁸⁸²

⁸⁷⁶ *Id.* at 33.

⁸⁷⁷ *See, e.g.,* Groeneveld Transp. Efficiency, Inc. v. Lubcore Int’l, Inc., 730 F.3d 494, 506, 508 (6th Cir. 2013) (“*TrafFix Devices* makes clear that [the plaintiff’s] argument about the availability of alternative . . . designs is misguided. . . . [C]ourts should not inquire into alternative designs when the design at issue is substantially influenced by functional considerations.”).

⁸⁷⁸ *See* Converse, Inc. v. Int’l Trade Comm’n, 909 F.2d 1110 (Fed. Cir. 2018).

⁸⁷⁹ *See id.* at 1114.

⁸⁸⁰ *Id.* at 1124.

⁸⁸¹ *See* Bodum USA, Inc. v. A Top New Casting Inc., 927 F.3d 486 (7th Cir. 2019).

⁸⁸² *See id.* at 490.



The court held the relevant inquiry to turn on an application of the following five factors: (1) disclosure of a utility patent involving or describing the functionality of the design; (2) the utilitarian properties of the design's unpatented elements; (3) any advertising by the plaintiff touting the utilitarian advantages of the design; (4) the availability of alternative designs; (5) the effect of the design on the product's quality or cost.⁸⁸³ It then found the jury's finding of nonfunctionality supported by a number of considerations, including: (1) the absence of potentially relevant utility patent claims (the district court had excluded from evidence several patents proffered by the defendant); (2) testimony from experts retained by both parties that no functional advantages attached to the shape of the handle; (3) a dearth of advertising featuring functional claims; (4) "a plethora of evidence regarding the availability of alternative designs"; (5) testimony from fact witnesses that the design was more expensive to produce than at least some alternatives.⁸⁸⁴

The existence of alternative designs also played a role in district courts' findings of nonfunctionality. For example, a South Carolina federal district court rejected as a matter of law a defense claim that the color orange, as used in connection with safe access and loading units, was functional in the utilitarian sense.⁸⁸⁵ The plaintiff owned a federal registration featuring the following drawing of its mark,

⁸⁸³ *Id.* at 492.

⁸⁸⁴ *Id.* at 494-95.

⁸⁸⁵ See *SafeRack, LLC v. Bullard Co.*, 350 F. Supp. 3d 438 (D.S.C. 2018), *report and recommendation adopted*, No. 2:17-cv-1613-RMG, 2019 WL 460699 (D.S.C. Feb. 5, 2019).

which led the court properly to characterize the defendant's allegations of functionality as an affirmative defense:⁸⁸⁶

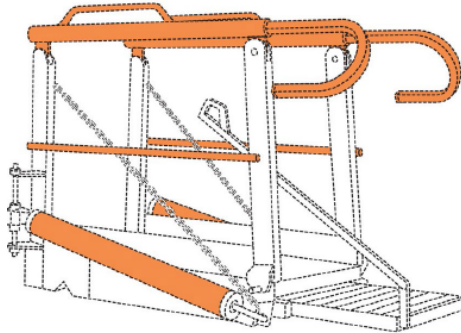

Attacking the mark's validity, the defendant argued the color served a safety-related attention-getting purpose, but the court found that claim unconvincing. It noted that “[b]right orange coloring on signs or equipment may sometimes be used to grab attention and indicate caution, yet there is no indication that the way in which [the plaintiff] uses orange . . . is functional.”⁸⁸⁷ This was especially true because the defendant had failed to introduce any proof that orange was the only color suited for that purpose. Instead, it found on the parties' cross-motions for summary judgment that undisputed record evidence and testimony “demonstrate[] that many other competitors use metallic gray or other colors, such as yellow.”⁸⁸⁸

Unusually, a different set of cross-motions for summary judgment in an action to protect the look and feel of the plaintiff's website led to a suggestion by the court that words can, under some circumstances, be functional in the utilitarian sense.⁸⁸⁹ Weighing the motions, the court accepted the defendant's argument that “[w]ords used ubiquitously as links on websites that sell services, such as ‘how it works’ and ‘pricing,’ or standard advertising features, such as use of a video, may be functional even though they are not part of the design of the underlying product”⁸⁹⁰ Ultimately, however, because “the placement, color, font, and size of such features come in nearly infinite variations,” the court found that “at least portions of the asserted trade dress were non-functional and operated only to give [the plaintiff's] website its look and feel.”⁸⁹¹

⁸⁸⁶ The graphic in the text accompanying this footnote is reproduced from U.S. Reg. 5211514 (issued May 30, 2017).

⁸⁸⁷ *SafeRack*, 350 F. Supp. 3d at 453.

⁸⁸⁸ *Id.*

⁸⁸⁹ *See Smartling, Inc. v. Skawa Innovation Ltd.*, 358 F. Supp. 3d 124 (D. Mass. 2019).

⁸⁹⁰ *Id.* at 148.

⁸⁹¹ *Id.*

If motions for summary judgment are sometimes inappropriate vehicles for resolving disputes over the utilitarian functionality or nonfunctionality of claimed trade dresses, so too are motions to dismiss. For example, a procedural stalemate occurred in an action to protect the configuration of a ballet flat shoe.⁸⁹² Characterizing the plaintiff's allegations of nonfunctionality as limited to "a single legal conclusion,"⁸⁹³ the defendant moved to dismiss the plaintiff's complaint for failure to state a claim. "To be sure," the court noted, "[the plaintiff's] functionality allegations are sparse: 'The shape and/or ornamental design of [the plaintiff's] product is nonfunctional.'"⁸⁹⁴ Nevertheless, "[b]ecause functionality 'involves an inherently factual review,' requiring a plaintiff 'to detail every contour of their trade dress claims run[s] afoul of Rule 8's pleading standard.'"⁸⁹⁵ Moreover, "[w]hile Defendants may ultimately be successful on this argument on summary judgment, the court is examining the sufficiency of the complaint and the incorporated documents,"⁸⁹⁶ which meant the court would not consider "extraneous materials" proffered by the defendants in support of their motion that purported to demonstrate the "omnipresent" use of similar designs in the industry.⁸⁹⁷ Finally, the court rejected the defendants' claim that the complaint description of the plaintiff's shoe "as being sustainable, having a comfortable fit, and being lightweight" itself established the shoe's functionality, explaining that "if only certain elements of the shoe are functional, this does not preclude a jury from finding that, taken as a whole, [the shoe] is nonfunctional."⁸⁹⁸

A similar failed motion to dismiss came in an action to protect the appearances of jamb brackets of a roller shade system.⁸⁹⁹ In denying the motion, the court accepted a number of averments in the plaintiff's complaint bearing on the inquiry, including that the brackets' configurations did not "provide a cost or quality advantage in the market."⁹⁰⁰ Although the defendants called the court's attention to statements in the plaintiff's promotional materials that its jams eliminated the need for valances, fascias, or ceiling pockets to hide the hardware and that they contained no visible wires or screws, the court found nothing in those statements evidencing why

⁸⁹² See *Rothy's, Inc. v. JKM Techs., LLC*, 360 F. Supp. 3d 373 (W.D. Va. 2018).

⁸⁹³ *Id.* at 384.

⁸⁹⁴ *Id.*

⁸⁹⁵ *Id.* (second alteration in original) (quoting *Stat Ltd. v. Beard Head, Inc.*, 60 F. Supp. 3d 634, 638 (E.D. Va. 2014)).

⁸⁹⁶ *Id.*

⁸⁹⁷ *Id.* at 384-85.

⁸⁹⁸ *Id.* at 385.

⁸⁹⁹ See *GeigTech E. Bay LLC v. Lutron Elecs. Co.*, 352 F. Supp. 3d 265 (S.D.N.Y. 2018).

⁹⁰⁰ *Id.* at 280.

the particular configurations at issue were essential to the use of the blinds or affected their cost or quality. Moreover, because it was necessary to consider the claimed trade dress in its entirety, “[i]t is irrelevant whether any individual element—for example, the jamb bracket—serves a functional purpose in the sense that it is used to install or operate the blinds.”⁹⁰¹

A final notable reported opinion bearing on utilitarian functionality, albeit one turning on only a procedural point, came from the Federal Circuit.⁹⁰² In the case producing an appeal to that court, the complainants convinced the International Trade Commission to initiate an investigation against a group of respondents accused of importing medical devices that infringed the trade dress of the complainants’ own competitive devices. Although the respondents defaulted and although it had approved the initial determination by its administrative law judge that the complaint adequately alleged the existence of a valid trade dress, the ITC declined to issue an exclusionary order because the nonfunctionality of the complainants’ trade dress was not apparent on the face of the complaint. The Federal Circuit vacated that determination, holding that, in light of the default, Section 337(g)(1) of the Tariff Act⁹⁰³ required the ITC to presume the truth of the complainants’ averments of nonfunctionality. It therefore remanded the proceeding for sole purpose of allowing the ITC to determine whether the public interest weighed against what otherwise should be a mandatory exclusion order.⁹⁰⁴

(b) Aesthetic Nonfunctionality

Findings of aesthetic functionality are rare at any stage of actions to protect nonverbal marks and trade dresses, but they are perhaps most infrequent as a matter of law on motions to dismiss. Nevertheless, one court disposed of an action before it using that mechanism after concluding that the plaintiff’s claimed trade dress was aesthetically functional.⁹⁰⁵ The plaintiff’s amended complaint defined that trade dress as “the ornamental appearance of carbon fiber style graphics applied in an arbitrary fashion to a portion of [automotive accessories],”⁹⁰⁶ and it offered an exemplar in the form of an air horn featuring those graphics. The court noted that “based upon the allegations in the amended complaint, the use of ‘carbon fiber style graphics applied in an arbitrary fashion’ on the horn is

⁹⁰¹ *Id.*

⁹⁰² See *Laerdal Med. Corp. v. Int’l Trade Comm’n*, 910 F.3d 1207 (Fed. Cir. 2018).

⁹⁰³ 19 U.S.C. § 1337(g)(1) (2018).

⁹⁰⁴ *Laerdal Med. Corp.*, 910 F.3d at 1216.

⁹⁰⁵ See *Wolo Mfg. Corp. v. ABC Corp.*, 349 F. Supp. 3d 176 (E.D.N.Y. 2018).

⁹⁰⁶ *Id.* at 204-05.

intended to render the product more appealing, rather than to identify the product's source."⁹⁰⁷ That was not enough, though, for "[s]ource identification . . . is the key consideration for trademark law's twin goals of protecting consumers from confusion and protecting manufacturers from unfair competition."⁹⁰⁸ The aesthetically appealing nature of the claimed trade dress therefore proved its downfall.

Nevertheless, that was not the usual disposition of claims of aesthetic functionality,⁹⁰⁹ and, indeed, several plaintiffs successfully convinced courts to reach actual findings of aesthetic nonfunctionality. For example, a New York federal district court rejected a claim of aesthetic functionality as a matter of law on the parties' cross-motions for summary judgment.⁹¹⁰ The counterclaim plaintiffs claimed ownership of the registered MARILYN MONROE and MARILYN marks for various licensed goods, including clothing, as well as Monroe's identity, persona, name, and likeness. Seeking to defeat the counterclaim plaintiffs' allegations of infringement, likely dilution, unfair competition, and false endorsement, the counterclaim defendants—who put out artwork featuring pop culture figures—argued that the counterclaim plaintiffs' rights were void under the aesthetic functionality doctrine. The court dismissed the suggestion that protection for Monroe's name and image "would undermine competitors' ability to compete in the marketplace,"⁹¹¹ and it therefore held the counterclaim plaintiffs entitled to summary judgment on the issue. The court did not explain its reasons for doing so, however, noting only that:

[T]he [counterclaim plaintiffs] point to significant activity in protecting the name and image of Monroe, and have presented evidence of both consumer complaints and consumer confusion. Furthermore, at other points the [counterclaim defendants] have suggested that other commercial actors make use of Marilyn Monroe's image, name, and likeness; those arguments undercut their present

⁹⁰⁷ *Id.* at 205.

⁹⁰⁸ *Id.* (quoting (quoting *Int'l Leisure Prods., Inc. v. Funboy LLC*, 747 F. App'x 23, 26 (2d Cir. 2018)).

⁹⁰⁹ *See, e.g., GeigTech E. Bay LLC v. Lutron Elecs. Co.*, 352 F. Supp. 3d 265, 281-82 (S.D.N.Y. 2018) ("It may very well be that Defendant can produce evidence at summary judgment showing that the specific combination of elements Plaintiff seeks to protect would put competitors at a significant non-reputation disadvantage (or, likewise, that Plaintiff cannot meet its statutory burden to prove that it does not). However, Plaintiff's allegations that protecting its trade dress would not hinder competition . . . , must be accepted as true for the purpose of a 12(b)(6) motion to dismiss.").

⁹¹⁰ *See A.V.E.L.A., Inc. v. Estate of Marilyn Monroe, LLC*, 364 F. Supp. 3d 291 (S.D.N.Y. 2019).

⁹¹¹ *Id.* at 313.

argument that no competitors to the [counterclaim plaintiffs] exist.⁹¹²

Albeit only in the preliminary injunction context, still another court rejected a claim that trade dress comprising the packaging for protein pancake mixes was aesthetically functional.⁹¹³ The defendant's argument to the contrary focused on the theory that so-called "kraft boxes" with a rustic feel were competitively necessary in the industry. The court found otherwise, concluding that "Plaintiff does not claim its trade dress is only a kraft box. It claims trade dress protection for all the elements of its packaging taken as a whole. Even if, as Defendant[s] argue[], the kraft box is functional, '[a] combination of features may be nonfunctional and thus protectable, even though the combination includes functional features.'"⁹¹⁴

Likewise, the appearance of a lollipop package additionally qualified as aesthetically nonfunctional.⁹¹⁵ As the court summarized them, "[t]he design features at issue here are: (1) a red bag with the brand in white lettering; (2) a display window in the bag showing suckers within; and (3) a blue and yellow [notice] indicating the number of lollipops within the bag."⁹¹⁶ Because the claimed trade dress was unregistered, the court properly placed the burden on the plaintiff to prove nonfunctionality, but it also observed that "the burden is 'not substantial,' requiring only a showing that the 'exclusive use of the feature would put competitors at a significant non-reputation-related disadvantage.'"⁹¹⁷ Turning to the features of the packaging at issue, it then found on the plaintiff's motion for a preliminary injunction that:

None of these three things are essential to packaging or selling lollipops. While the color red may serve a purpose, it is not the only color which may be used to communicate that the package contains lollipops. The same applies to the [notice], which could accurately communicate the number of lollipops within the bag in any color. Finally, the window in the bag might serve the purpose of communicating what is contained therein. But the same purpose can be accomplished through other means such as labeling the bag,

⁹¹² *Id.*

⁹¹³ *See* Kodiak Cakes LLC v. Cont'l Mills, Inc., 358 F. Supp. 3d 1219 (D. Utah 2019).

⁹¹⁴ *Id.* at 1235 (quoting Hartford House, Ltd. v. Hallmark Cards, Inc., 846 F.2d 1268, 1272 (10th Cir. 1988)).

⁹¹⁵ *See* Spangler Candy Co. v. Tootsie Roll Indus., 372 F. Supp. 3d 588 (N.D. Ohio), *appeal dismissed*, No. 19-3227, 2019 WL 2564576 (6th Cir. May 10, 2019).

⁹¹⁶ *Id.* at 603.

⁹¹⁷ *Id.* (quoting Leapers, Inc. v. SMTS, LLC, 879 F.3d 731, 741 (6th Cir. 2018); Qualitex Co. v. Jacobson Prods. Co., 514 U.S. 159, 165 (1995)).

as evident by the numerous candy bags that do not possess the window.⁹¹⁸

The plaintiff's proof of aesthetic nonfunctionality therefore did the job.

iii. Establishing Liability for Violations of Trademark and Service Mark Rights

(A) Actionable Uses in Commerce by Defendants

As a prerequisite for liability, the Lanham Act's primary statutory causes of action, namely, those set forth in Sections 32,⁹¹⁹ 43(a),⁹²⁰ and 43(c),⁹²¹ each require the challenged use be one in connection with goods or services in commerce. Likewise, corresponding state law causes of actions often contemplate similar showings by plaintiffs, albeit without requiring that use to occur across state lines.⁹²² These requirements often lead defendants to challenge the adequacy of plaintiffs' averments or proof of the necessary use.

(1) Opinions Finding Actionable Uses in Commerce

The easiest way for a plaintiff to establish the existence of an actionable use in commerce is obviously to have its opponent fail to contest the issue. One plaintiff getting lucky in this manner targeted a pair of defendants allegedly infringing the plaintiff's marks for kitchen and bath fixtures.⁹²³ Although the court did not reflexively grant the plaintiff's motion for a default judgment, choosing instead to conduct a full evaluation of the sufficiency of the plaintiff's complaint, it nevertheless concluded the defendants had sufficiently used their mark in commerce to establish the plausibility of the plaintiff's claims of infringement. The salient allegations in the complaint were that: (1) the defendants had advertised goods under their mark at a 2017 trade show; (2) one of the defendants actually had sold goods under the mark out of a New

⁹¹⁸ *Id.*

⁹¹⁹ 15 U.S.C. § 1114 (2018).

⁹²⁰ *Id.* § 1125(a).

⁹²¹ *Id.* § 1125(c).

⁹²² *See, e.g.*, N.Y. Gen. Bus. Law 360-k(a) (McKinney 2012) (providing for cause of action against "any person who shall . . . (a) use, without the consent of the registrant, any reproduction, counterfeit, copy, or colorable imitation of a mark registered under this article in connection with the sale, distribution, offering for sale, or advertising of any goods or services on or in connection with which such use is likely to cause confusion or mistake or to deceive as to the source of origin of such goods or services").

⁹²³ *See Kohler Co. v. Bold Int'l FZCO*, 127 U.S.P.Q.2d 1459 (E.D.N.Y. 2018), *report and recommendation adopted in relevant part*, No. 17-cv-4233 (LDH) (RLM), 2018 WL 4804655 (E.D.N.Y. Oct. 4, 2018).

York warehouse; and (3) the same defendant was actively advertising goods (again in connection with the allegedly infringing mark) on its website.⁹²⁴ According to the court, [t]hese factual allegations . . . support that each defendant “used in commerce” the [allegedly infringing] mark “in connection with” the sale, distribution, or advertisement of goods.⁹²⁵

Even when they disputed plaintiffs’ claims of use in commerce, defendants often found themselves on the losing side of the issue. For example, reaching a conclusion later expressly rejected by another tribunal hearing a case on closely similar facts,⁹²⁶ a Wisconsin federal district court concluded that the lead defendant, an online marketplace, had used counterfeit imitations of the plaintiffs’ marks within the scope of Section 32.⁹²⁷ The defendant contested the issue by arguing it did not itself use the accused marks in commerce, but the court found “little need for [an] extended discussion” of that position.⁹²⁸ On the contrary:

[The lead defendant] maintains [a] database [containing artwork with authorized copies of the plaintiffs’ marks], advertises infringing designs and trains and encourages others to do so, owns and runs its automated printers that print the infringing designs onto physical goods, handles products after they come off of the printers, bags and ships those products, and processes payment. This is use in commerce.”⁹²⁹

The court then rejected the lead defendant’s claim that its conduct was nonactionable because the uses in question were merely ornamental, observing in the process that “[t]he notion that a logo, word, or other designation needs to be used as a trademark ‘is not a necessary element of a trademark infringement claim.’”⁹³⁰

A particularly brazen attempt by a group of defendants to pass themselves off as affiliates of the plaintiff also led to findings of actionable uses in commerce as a matter of law in a case before a California federal district court.⁹³¹ The plaintiff had dissolved certain subsidiaries, after which, apparently under the impression

⁹²⁴ *Id.* at 1466.

⁹²⁵ *Id.*

⁹²⁶ *See* Ohio State Univ. v. Redbubble, Inc., 369 F. Supp. 3d 840 (S.D. Ohio 2019).

⁹²⁷ *See* H-D U.S.A., LLC v. SunFrog, LLC, 311 F. Supp. 3d 1000 (E.D. Wis.), *appeal dismissed*, No. 18-2073, 2018 WL 6039900 (7th Cir. July 19, 2018).

⁹²⁸ *Id.* at 1029.

⁹²⁹ *Id.* at 1029-30.

⁹³⁰ *Id.* at 1030 (quoting Univ. Healthsystem Consortium v. UnitedHealth Grp., 68 F. Supp. 3d 917, 926 (N.D. Ill. 2014)).

⁹³¹ *See* AECOM Energy & Constr., Inc. v. Ripley, 348 F. Supp. 3d 1038 (C.D. Cal. 2018), *reconsideration denied*, No. CV 17-5398-RSWL-SSx, 2019 WL 2610953 (C.D. Cal. Apr. 24, 2019), *appeal docketed*, No. 19-55588 (9th Cir. May 23, 2019).

that the marks used by those subsidiaries had gone abandoned, the defendants made spurious corporate filings putatively reviving the subsidiaries. They then established a website accessible at two domain names corresponding to one of the subsidiaries' marks and issued press releases claiming credit for construction projects actually undertaken by one of the dissolved subsidiaries. Moreover, the defendants used an e-mail address incorporating that mark to receive potential bids and respond to requests for information. On these facts, the court not surprisingly found it beyond material dispute that the defendants had used the marks in commerce. It did so in rather cursory form, however, observing only that "[c]ommunications made on public websites' satisfy the use in commerce requirement."⁹³²

A finding of an actionable use in commerce also came in a battle between litigants in the Minnesota party bus market.⁹³³ To establish liability at trial, the plaintiffs pointed to the defendants' use on a promotional website site and in social media of exact reproductions of two marks owned by the plaintiffs. Faced with those showings, the defendants argued ineffectually that the uses in question were "minor" because they did not appear on the defendants' main website. The court rejected that argument, holding instead that "the extent of the use is irrelevant to whether the use was in commerce."⁹³⁴ Of equal importance, "the website and social media postings were the product of [the defendants'] contract with [a third party] for marketing [the defendants'] website using the marks."⁹³⁵ Under these circumstances, "[t]he Court finds that [the defendants] used the marks in commerce."⁹³⁶

A final notable opinion addressing this prerequisite for liability did so in response to a defense motion for summary judgment.⁹³⁷ According to the lead defendant, it had not itself used the challenged mark; instead, it had merely licensed the mark's use to third parties. The court rejected that claim, at least for purposes of the defendants' motion for summary judgment: "The Court concludes that [the plaintiffs'] evidence of [the lead defendant's] licensing agreements, branding and promotional efforts, web presence, and opening of

⁹³² *Id.* at 1049 (quoting *Nat'l Grange of the Order of Patrons of Husbandry v. Cal. State Grange*, No. 2:16-201 WBS DB, 2016 WL 6696061, at *4 (E.D. Cal. Nov. 15, 2016)).

⁹³³ *See Safeway Transit LLC v. Disc. Party Bus, Inc.*, 334 F. Supp. 3d 995 (D. Minn. 2018), *appeal docketed*, No. 18-2990 (8th Cir. Sept. 17, 2018).

⁹³⁴ *Id.* at 1006.

⁹³⁵ *Id.*

⁹³⁶ *Id.*

⁹³⁷ *See Gianni Versace, S.p.A., v. Versace 19.69 Abbigliamento Sportivo SRL*, 328 F. Supp. 3d 1007 (N.D. Cal. 2018), *appeal dismissed*, No. 19-15188, 2019 WL 2005744 (9th Cir. Apr. 17, 2019).

brick and mortar locations is sufficient at the summary judgment stage to show ‘use’ for purposes of liability.”⁹³⁸

(2) Opinions Declining to Find Actionable Uses in Commerce

A particularly aggressive finding of no actionable use in commerce was affirmed in a case appealed to a Pennsylvania intermediate appellate court by a medical center.⁹³⁹ That plaintiff had engaged a plastic surgeon, who, while enjoying staff privileges at one of the plaintiff’s West Virginia facilities, entered into an agreement with the defendants to produce a putative reality show to be called *Drastic Plastic*. That agreement led to the creation of a so-called “sizzle reel” video featuring individuals identifying themselves as the surgeon’s patients and employees. “Throughout the Video,” the plaintiff’s complaint recited, “patients are frequently and pejoratively called ‘crazy.’ Countless, highly offensive references are made concerning [the surgeon’s] work in breast augmentation. Additionally, the Video portrays the residents of West Virginia as uneducated and willing to waste money on unnecessary plastic surgery.”⁹⁴⁰ Although the complaint additionally alleged that the video “appears to include images of actual patient medical files,”⁹⁴¹ it neglected to accuse the defendants of using any trademark or service mark belonging to the plaintiff. That failure produced a dismissal of the complaint for failure to state a claim before the trial court, a disposition with which the appellate court agreed.⁹⁴²

A second defense victory—one by a defaulting defendant—did not produce an appellate opinion.⁹⁴³ It came in a case in which the owner of the FORTNITE mark for a survival-and-action video game accused a group of defendants of creating “software ‘cheats’ that allow players to modify Fortnite to give themselves unfair competitive advantages over other players, thereby undermining the integrity of Fortnite and ruining the game-play experience for players who play without cheats.”⁹⁴⁴ When the defaulting defendant failed to respond to the plaintiff’s complaint, the plaintiff requested the court to enter a finding of liability against him, citing his online posting of a video “that demonstrated and provided a link to

⁹³⁸ *Id.* at 1031.

⁹³⁹ *See Weirton Med. Ctr. v. Introublezone, Inc.*, 193 A.3d 967 (Pa. Sup. Ct. 2018).

⁹⁴⁰ *Id.* at 970.

⁹⁴¹ *Id.*

⁹⁴² *Id.* at 974.

⁹⁴³ *See Epic Games, Inc. v. Mendes*, 127 U.S.P.Q.2d 1387 (N.D. Cal. 2018).

⁹⁴⁴ *Id.* at 1391.

download his cheat.”⁹⁴⁵ Unfortunately for that request, however, the court found that “[the plaintiff] does not plead that [the defaulting defendant] proposed any commercial transaction or offered anything for sale, much less that consumers would be misled into buying something from him or any other third party under the mistaken belief that it was coming from [the defendant].”⁹⁴⁶ That omission, the court held, prevented the plaintiff from prevailing even in the absence of opposition to its request for a default judgment.

Findings of no actionable uses in commerce as a matter of law also came on motions for summary judgment. When The Ohio State University discovered the online sale of goods bearing imitations of its federally registered marks, it filed suit against the online platform on which the goods appeared.⁹⁴⁷ Claiming it did not use the University’s marks in commerce because it was not the “seller” of the goods, the defendant successfully moved for summary judgment. According to the court, “[t]he caselaw sets up a spectrum against which to measure [the defendant’s] conduct. At one end are companies that function like auction houses and are not liable for direct infringement. At the other end are companies . . . that themselves manufacture and ship infringing products to the customer[, which can be].”⁹⁴⁸ It then credited the defendant’s showing that:

[The defendant] essentially offers to “independent artists” an online platform through which to sell their goods and access to [the defendant’s] relationships with manufacturers and shippers. [The defendant] is not directly producing the goods nor . . . is [the defendant] maintaining a design database and then placing the designs onto goods that customers order.⁹⁴⁹

Under the circumstances, the court concluded, “[the defendant] is not liable for direct trademark infringement” because it was not using the University’s marks in commerce.⁹⁵⁰ It then reached the same conclusion under the Ohio right of publicity statute⁹⁵¹ based on the court’s reading of the statute to include a requirement of use in commerce.⁹⁵²

⁹⁴⁵ *Id.* at 1393.

⁹⁴⁶ *Id.* at 1398.

⁹⁴⁷ *See* *Ohio State Univ. v. Redbubble, Inc.*, 369 F. Supp. 3d 840 (S.D. Ohio 2019).

⁹⁴⁸ *Id.* at 845-46.

⁹⁴⁹ *Id.* at 846.

⁹⁵⁰ *Id.* at 847.

⁹⁵¹ Ohio Rev. Code § 2741 (2010).

⁹⁵² *Ohio State Univ.*, 369 F. Supp. 3d at 847-48.

A defense motion for summary judgment in a different case yielded the same result.⁹⁵³ The parties to that dispute competed in the market for mobile aircraft arresting systems. When the United States Air Force used the plaintiff's PORTARREST trademark in the title of a solicitation, the defendants responded to the solicitation with an e-mail message including the plaintiff's mark and transmitting a bid package that also referred to the mark. In granting the defendants' motion for summary judgment, the court concluded that "[b]oth of these uses of [the mark] are references to the title of the USAF solicitation and not a 'use in commerce' of [the mark]."⁹⁵⁴ It then rejected the plaintiff's reliance on the mark's appearance in a "Past Performance" annex to the defendants' proposal for the same reason: "Once again, these are references to the labels USAF gave to contracts and not a 'use in commerce' of 'PORTARREST.'"⁹⁵⁵ An additional reference to the mark in a separate promotional piece also failed to create a factual dispute because that reference was "a literal description of the [Air Force's] solicitation process."⁹⁵⁶ "Finally," the court found, "the defendants did not use 'PORTARREST' when they responded to the solicitation, responded to the amendments, or signed the contract—all documents that contained 'PORTARREST.' USAF, not the defendants, included [the] 'PORTARREST' [mark] in those documents."⁹⁵⁷

(3) Opinions Deferring Resolution of the Actionable-Use-in-Commerce Inquiry

Reported opinions declining to resolve the use-in-commerce inquiry on motions for summary judgment are rare, but one doing so came from an Alabama federal district court.⁹⁵⁸ The gravamen of the plaintiff's claims under Section 43(a) and Alabama state law was that the defendants had reregistered a series of domain names incorporating the plaintiff's geographically descriptive marks after the marks had become protectable through the acquisition of secondary meaning. Although the defendants engaged in various allegedly unlawful activities before that point in time, they discontinued them before the plaintiff's rights vested. Consequently, the plaintiff could not proffer anything on a post-vesting basis except for the defendants' reregistration of the domain names. Nevertheless, when coupled with the defendants' pre-vesting

⁹⁵³ See *Engineered Arresting Sys. Corp. v. Atech, Inc.*, 356 F. Supp. 3d 1323 (N.D. Ala. 2018).

⁹⁵⁴ *Id.* at 1343.

⁹⁵⁵ *Id.*

⁹⁵⁶ *Id.*

⁹⁵⁷ *Id.*

⁹⁵⁸ See *ZP No. 314, LLC v. ILM Capital, LLC*, 335 F. Supp. 3d 1242 (S.D. Ala. 2018).

conduct, that was enough for the denial of the defendants' motion for summary judgment, even if it did not mandate the grant of the plaintiff's cross-motion:

This evidence arguably suggests that Defendants were using the confusingly similar domain names "in commerce" . . . when they re-registered the domain name websites on the Internet. To the extent that Defendants assert that they merely "parked" the websites on the Internet after [the plaintiff's acquisition of rights], . . . their actions in parking the names, and thereby preventing [the plaintiff's] commercial use of the names, could arguably constitute use "in commerce," thus creating a genuine issue of material fact on this issue.⁹⁵⁹

The court then reached the same conclusion under Alabama law.⁹⁶⁰

(B) Likelihood of Confusion

(1) The Standard Multifactor Test for Likelihood of Confusion

(a) Factors Considered

(i) The First Circuit

The sole reported opinion arising in the First Circuit to address a claim of likely confusion applied an eight-factor standard, which took into account: (1) the similarity of the parties' marks; (2) the similarity of the parties' goods or services; (3) the relationship between the parties' channels of trade; (4) the relationship between the parties' advertising; (5) the classes of the parties' prospective purchasers; (6) evidence of actual confusion; (7) the defendant's intent in adopting its mark; and (8) the strength of the plaintiff's mark.⁹⁶¹

(ii) The Second Circuit

As usual, the *Polaroid* factors⁹⁶² governed applications of the likelihood-of-confusion test for infringement in the Second Circuit, with courts there examining: (1) the strength of the plaintiff's mark; (2) the degree of similarity between the marks; (3) the proximity of the goods or services; (4) the likelihood of the senior user bridging any gap between its goods or services and those of the junior user; (5) evidence of actual confusion between the parties' marks; (6) whether the defendant adopted its mark in good faith; (7) the

⁹⁵⁹ *Id.* at 1266-67.

⁹⁶⁰ *Id.* at 1268-69.

⁹⁶¹ *See Smartling, Inc. v. Skawa Innovation Ltd.*, 358 F. Supp. 3d 124, 139 (D. Mass. 2019).

⁹⁶² *See Polaroid Corp. v. Polarad Elecs. Corp.*, 287 F.2d 492, 495 (2d Cir. 1961).

quality of the defendant's goods or services; and (8) the sophistication of the parties' respective customers.⁹⁶³

(iii) The Third Circuit

Unusually, no reported opinions addressed the Third Circuit's *Lapp* test for likelihood of confusion.⁹⁶⁴

(iv) The Fourth Circuit

The Fourth Circuit test for likely confusion turned on examinations of the following nine factors: (1) the strength of the plaintiff's mark; (2) the degree of similarity between the parties' marks; (3) the similarity between the parties' goods and services; (4) the similarity of the facilities used by the parties; (5) the similarity of the parties' advertising; (6) the defendant's intent; (7) the presence of actual confusion; (8) the quality of the defendant's goods or services; and (9) the sophistication of the consumers targeted by the parties.⁹⁶⁵

(v) The Fifth Circuit

Although the Fifth Circuit once applied a seven-factor test for infringement,⁹⁶⁶ recent opinions have confirmed the court's expansion of that test to eight "digit[s] of confusion." Those digits included the following nonexclusive considerations: (1) the type of the plaintiff's mark; (2) the similarity between the parties' marks;

⁹⁶³ See *A.V.E.L.A., Inc. v. Estate of Marilyn Monroe, LLC*, 364 F. Supp. 3d 291, 309 (S.D.N.Y. 2019); *Drone Racing League, Inc. v. DR1, LLC*, 129 U.S.P.Q.2d 1083, 1086 (S.D.N.Y. 2018); *GeigTech E. Bay LLC v. Lutron Elecs. Co.*, 352 F. Supp. 3d 265, 285 (S.D.N.Y. 2018); *Knowles-Carter v. Feyonce, Inc.*, 347 F. Supp. 3d 217, 224 (S.D.N.Y. 2018); *Museum of Modern Art v. MOMACHA IP LLC*, 339 F. Supp. 3d 361, 373 (S.D.N.Y. 2018); *Hypnotic Hats, Ltd. v. Wintermantel Enters.*, 335 F. Supp. 3d 566, 582 (S.D.N.Y. 2018); *Spin Master Ltd. v. Alan Yuan's Store*, 325 F. Supp. 3d 413, 421 (S.D.N.Y. 2018); *Kohler Co. v. Bold Int'l FZCO*, 127 U.S.P.Q.2d 1459, 1467 (E.D.N.Y. 2018), *report and recommendation adopted in relevant part*, No. 17-cv-4233 (LDH) (RLM), 2018 WL 4804655 (E.D.N.Y. Oct. 4, 2018); *Disney Enters. v. Sarelli*, 322 F. Supp. 3d 413, 430 (S.D.N.Y. 2018), *reconsideration denied*, No. 16 CIV. 2340 (GBD), 2018 WL 5019745 (S.D.N.Y. Sept. 26, 2018); *Thousand Island Park Corp. v. Welser*, 314 F. Supp. 3d 391, 397 (N.D.N.Y. 2018).

⁹⁶⁴ See *Interpace Corp. v. Lapp, Inc.*, 721 F.2d 460, 463 (3d Cir. 1983).

⁹⁶⁵ See *RXD Media, LLC v. IP Application Dev.*, 377 F. Supp. 3d 588, 594 (E.D. Va. 2019), *appeal docketed*, No. 19-1461 (4th Cir. Apr. 30, 2019); *Combe Inc. v. Dr. August Wolff GmbH & Co. KG Arzneimittel*, 382 F. Supp. 3d 429, 444 (E.D. Va. 2019), *appeal docketed*, No. 19-1674 (4th Cir. June 24, 2019); *Rothy's, Inc. v. JKM Techs., LLC*, 360 F. Supp. 3d 373, 385-86 (W.D. Va. 2018); *BHR Recovery Cmtys., Inc. v. Top Seek, LLC*, 355 F. Supp. 3d 416, 426 (E.D. Va. 2018); *SafeRack, LLC v. Bullard Co.*, 350 F. Supp. 3d 438, 448-49 (D.S.C. 2018), *report and recommendation adopted*, No. 2:17-cv-1613-RMG, 2019 WL 460699 (D.S.C. Feb. 5, 2019); *Mayson-Dixon Strategic Consulting, LLC v. Mason-Dixon Polling & Strategic Consulting, Inc.*, 324 F. Supp. 3d 569, 577-78 (D. Md. 2018).

⁹⁶⁶ See, e.g., *Roto-Rooter Corp. v. O'Neal*, 513 F.2d 44, 45-46 (5th Cir. 1975).

(3) the competitive proximity between the parties' goods or services; (4) the similarities between the parties' outlets and purchasers; (5) the similarity between the parties' advertising media; (6) the defendant's intent; (7) actual confusion; and (8) the care exercised by potential purchasers of the parties' goods or services.⁹⁶⁷

(vi) The Sixth Circuit

The eight *Frisch's* factors⁹⁶⁸ remained those of choice in the Sixth Circuit. They included: (1) the strength of the plaintiff's mark; (2) the relatedness of the parties' goods or services; (3) the similarity of the parties' marks; (4) evidence of any actual confusion; (5) the marketing channels used by the parties; (6) the probable degree of purchaser care and sophistication; (7) the defendant's intent in selecting its mark; and (8) the likelihood of either party expanding its product line under its mark.⁹⁶⁹ Consistent with its usual practice, the Sixth Circuit itself characterized the likelihood-of-confusion inquiry as a mixed question of law and fact.⁹⁷⁰

(vii) The Seventh Circuit

As they have for decades, likelihood-of-confusion determinations in the Seventh Circuit turned on seven factors. Those were: (1) the degree of similarity between the parties' marks in appearance and suggestion; (2) the degree of similarity between the parties' products; (3) the area and manner of concurrent use; (4) the degree of care likely to be exercised by consumers; (5) the strength of complainant's mark; (6) the extent of any actual confusion; and (7) the defendant's intent to palm off his goods or services as those of the plaintiff.⁹⁷¹

⁹⁶⁷ See *All. for Good Gov't v. Coal. for Better Gov't*, 901 F.3d 498, 508, 513 (5th Cir. 2018); *Cross Trailers, Inc. v. Cross Trailer Mfg. & Sales, LLC*, 363 F. Supp. 3d 781 (W.D. Tex. 2018); *Helpful Hound, L.L.C. v. New Orleans Bldg. Corp.*, 331 F. Supp. 3d 581, 600 (E.D. La. 2018).

⁹⁶⁸ See *Frisch's Rest., Inc. v. Shoney's Inc.*, 759 F.2d 1261, 1264 (6th Cir. 1985).

⁹⁶⁹ See *Sterling Jewelers, Inc. v. Artistry Ltd.*, 896 F.3d 752, 756 (6th Cir. 2018); *Spangler Candy Co. v. Tootsie Roll Indus.*, 372 F. Supp. 3d 588, 604 (N.D. Ohio), *appeal dismissed*, No. 19-3227, 2019 WL 2564576 (6th Cir. May 10, 2019); see also *Vanderbilt Univ. v. Scholastic, Inc.*, 382 F. Supp. 3d 734, 750-51 (M.D. Tenn. 2019) (referencing eight-factor test without identifying factors).

⁹⁷⁰ *Sterling Jewelers*, 896 F.3d at 755.

⁹⁷¹ See *Uncommon, LLC v. Spigen, Inc.*, 926 F.3d 409, 425 (7th Cir. 2019); *Entm't One UK Ltd. v. 2012Shiliang*, 384 F. Supp. 3d 941, 950 (N.D. Ill. 2019); *Sullivan v. Bickler*, 360 F. Supp. 3d 778, 787 (N.D. Ill. 2019); *H-D U.S.A., LLC v. SunFrog, LLC*, 311 F. Supp. 3d 1000, 1032 (E.D. Wis.), *appeal dismissed*, No. 18-2073, 2018 WL 6039900 (7th Cir. July 19, 2018).

(viii) The Eighth Circuit

The six *SquirtCo* factors⁹⁷² remained controlling in the Eighth Circuit. Those factors included: (1) the strength of the plaintiff's mark; (2) the similarity between the plaintiff's mark and the defendant's mark; (3) the competitive proximity between the parties' goods or services; (4) the defendant's intent to pass off its goods as those of the plaintiff; (5) incidents of actual confusion; and (6) the conditions under which the parties' goods or services were sold and the degree of care exercised by purchasers.⁹⁷³

(ix) The Ninth Circuit

The *Sleekcraft* test for infringement⁹⁷⁴ continued to govern likelihood-of-confusion inquiries in the Ninth Circuit. It considered the following factors: (1) the strength of the plaintiff's mark; (2) the proximity or relatedness of the parties' goods; (3) the similarity of the parties' marks; (4) evidence of actual confusion; (5) the marketing channels used by the parties; (6) the type of the parties' goods or services and the degree of care likely to be exercised by purchasers; (7) the defendant's intent in selecting its mark; and (8) the likelihood of an expansion of the parties' lines of goods or services.⁹⁷⁵

(x) The Tenth Circuit

The Tenth Circuit's test for likely confusion continued to turn on an examination of six factors. They were: (1) the degree of similarity between the marks; (2) the intent of the alleged infringer in adopting its mark; (3) evidence of actual confusion; (4) the relation in use and the manner of marketing between the goods or services marketed by the competing parties; (5) the degree of care likely to be exercised by purchasers; and (6) the strength or weakness of the plaintiff's mark.⁹⁷⁶

⁹⁷² See *SquirtCo v. Seven-Up Co.*, 628 F.2d 1086, 1091 (8th Cir. 1980).

⁹⁷³ See *Safeway Transit LLC v. Disc. Party Bus, Inc.*, 334 F. Supp. 3d 995, 1006 (D. Minn. 2018), *appeal docketed*, No. 18-2990 (8th Cir. Sept. 17, 2018); *Shipyard Brewing Co. v. Logboat Brewing Co.*, 127 U.S.P.Q.2d 1187, 1190 (W.D. Mo. 2018).

⁹⁷⁴ See *AMF, Inc. v. Sleekcraft Boats*, 599 F.2d 341, 348-49 (9th Cir. 1979).

⁹⁷⁵ See *Comphy Co. v. Amazon.com, Inc.*, 371 F. Supp. 3d 914, 925 (W.D. Wash. 2019); *Clean Crawl, Inc. v. Crawl Space Cleaning Pros, Inc.*, 364 F. Supp. 3d 1194, 1204 (W.D. Wash. 2019); *Las Vegas Sands Corp. v. Fan Yu Ming*, 360 F. Supp. 3d 1072, 1076 (D. Nev. 2019); *Daimler AG v. A-Z Wheels LLC*, 334 F. Supp. 3d 1087, 1095 (S.D. Cal. 2018); *Gianni Versace, S.p.A., v. Versace 19.69 Abbigliamento Sportivo SRL*, 328 F. Supp. 3d 1007, 1015 (N.D. Cal. 2018), *appeal dismissed*, No. 19-15188, 2019 WL 2005744 (9th Cir. Apr. 17, 2019); *JL Beverage Co. v. Beam, Inc.*, 318 F. Supp. 3d 1188, 1203 (D. Nev. 2018).

⁹⁷⁶ See *Cent. Bancorp, Inc. v. Cent. Bancompany, Inc.*, 385 F. Supp. 3d 1122, 1140 (D. Colo. 2019); *Kodiak Cakes LLC v. Cont'l Mills, Inc.*, 358 F. Supp. 3d 1219, 1229 (D. Utah 2019).

(xi) The Eleventh Circuit

Courts in the Eleventh Circuit applied the same test for likely confusion they always have. Its seven factors took into account: (1) the type of the plaintiff's mark; (2) the similarity of the parties' marks; (3) the similarity of the parties' products; (4) the similarity of the parties' retail outlets and customers; (5) the similarity of the parties' advertising media; (6) the defendant's intent; and (7) any actual confusion.⁹⁷⁷

(xii) The District of Columbia Circuit

For decades, federal district courts and litigants grappling with the issue of likely confusion in the nation's capital have lacked guidance from the United States Court of Appeals the District of Columbia Circuit as to the factors properly governing the infringement inquiry. That changed, however, with the following holding from the court:

Although our court has yet to opine on the precise factors courts should consider when assessing likelihood of confusion, our sister circuits have adopted similar multi-factor tests, all of which “owe their origin to the 1938 Restatement of Torts.” Factors considered include the strength of the mark, the similarity of the marks, the proximity of the goods, the similarity of the parties' marketing channels, evidence of actual confusion, the defendant's intent in adopting the mark, the quality of the defendant's product, and the sophistication of the buyers.⁹⁷⁸

(b) Findings and Holdings

(i) Opinions Finding Likelihood of Confusion on Motions for Preliminary Injunctive Relief

As always, preliminary injunctive relief held in cases in which defendants failed to contest the issue⁹⁷⁹ or when a rogue existing or former licensee used a disputed mark outside the scope of its

⁹⁷⁷ See *Hard Candy, LLC v. Anastasia Beverly Hills, Inc.*, 921 F.3d 1343, 1360 (11th Cir. 2019); *PlayNation Play Sys., Inc. v. Vexel Corp.*, 924 F.3d 1159, 1165 (11th Cir. 2019); *Yellowfin Yachts, Inc. v. Barker Boatworks, LLC*, 898 F.3d 1279, 1289 (11th Cir. 2018); *Canes Bar & Grill of S. Fla., Inc. v. Sandbar Bay, LLC*, 343 F. Supp. 3d 1236, 1243 (S.D. Fla. 2018).

⁹⁷⁸ *Am. Soc'y for Testing & Materials v. Public.Resource.Org, Inc.*, 896 F.3d 437, 456 (D.C. Cir. 2018) (quoting J. Thomas McCarthy, *McCarthy on Trademarks and Unfair Competition* § 24:30 (5th ed. 2018)).

⁹⁷⁹ See, e.g., *Las Vegas Sands Corp. v. Fan Yu Ming*, 360 F. Supp. 3d 1072, 1076 (D. Nev. 2019) (holding that defendants' failure to contest plaintiffs' preliminary injunction motion constituted consent to entry of relief sought).

agreement with the mark's owner.⁹⁸⁰ An example of a case presenting the latter scenario came after the lessor of a city-owned and ST. ROCH MARKET-branded food hall in New Orleans and its affiliates began using the ST. ROCH MARKET mark to promote a similar food hall in Miami and announced their possible plans to expand that use further into Chicago and St. Louis.⁹⁸¹ The counterclaim defendants suffered two losses early in the court's opinion that left them considerably disadvantaged in the likelihood-of-confusion inquiry, namely: (1) the city and one of its agencies, the counterclaim plaintiffs, enjoyed priority of rights to the mark; and (2) the counterclaim defendants' bad faith justified injunctive relief outside the limited geographic market in which the counterclaim plaintiffs' food hall operated. Against the backdrop of those factual findings, the identity of the parties' marks and the directly competitive nature of their services left the court with little doubt that confusion was likely, despite the geographically descriptive (and therefore weak) nature of the mark at issue.⁹⁸²

In another case involving a prior agreement between the parties, the court had little difficulty finding confusion likely between the following marks for competing sports bars located slightly more than ten miles apart in Florida:⁹⁸³

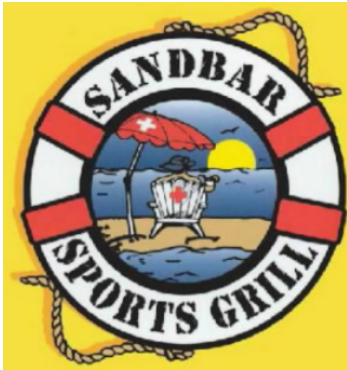

The defendants did not contest the similarity of the parties' respective uses, the competitive nature of their services, and their

⁹⁸⁰ See, e.g., *Marco's Franchising, LLC v. Soham, Inc.*, 365 F. Supp. 3d 891, 895 (N.D. Ohio 2019) (entering preliminary injunction and explaining that "[a] plaintiff can establish 'likelihood of confusion' by showing 'proof of continued, unauthorized use of an original trademark by one whose license to use the trademark had been terminated'" (quoting *U.S. Structures, Inc. v. J.P. Structures, Inc.*, 130 F.3d 1185, 1190 (6th Cir. 1997))).

⁹⁸¹ See *Helpful Hound, L.L.C. v. New Orleans Bldg. Corp.*, 331 F. Supp. 3d 581 (E.D. La. 2018).

⁹⁸² *Id.* at 600-02.

⁹⁸³ See *Canes Bar & Grill of S. Fla., Inc. v. Sandbar Bay, LLC*, 343 F. Supp. 3d 1236, 1241 (S.D. Fla. 2018).

overlapping customer base.⁹⁸⁴ Moreover, the court found that the plaintiff had carried its burden by demonstrating the arbitrary nature of its marks,⁹⁸⁵ shared advertising media,⁹⁸⁶ “sufficient circumstantial evidence to support a finding that Defendants intended to derive a benefit from Plaintiff’s reputation,”⁹⁸⁷ and actual confusion in the form of social media posts confusing the parties.⁹⁸⁸ In the face of those showings, the defendants claimed entitlement to use their mark and logo under a prior agreement between the plaintiff and one of the defendants. The court rejected that argument, however, which left a finding of likely confusion between the parties’ uses a foregone conclusion.

In another case leading to an easily granted preliminary injunction motion, the counterclaim plaintiff was a political consulting firm operating under the MASON-DIXON mark, while the counterclaim defendant provided directly competitive services under the MAYSON-DIXON mark.⁹⁸⁹ Although the counterclaim plaintiff’s mark clearly consisted of two surnames, the court surprisingly found it “arbitrary or fanciful, because there is no connection between the term ‘Mason-Dixon’ and the nature of the services offered by [the counterclaim plaintiff]”;⁹⁹⁰ less surprisingly, it found the mark commercially, as well as conceptually, strong in light of the mark’s exclusive use by the counterclaim plaintiff “for decades,” favorable media attention paid to the counterclaim plaintiff’s services, and the mark’s recognition “as a reliable indicator of source for independent polling and consulting services.”⁹⁹¹ It was all over for the counterclaim defendant from there, with the court finding that the marks themselves were confusingly similar,⁹⁹² that the parties both used “face-to-face meetings, phone calls, emails, and the Internet” when conducting their business,⁹⁹³ that they used the same advertising media in overlapping geographic markets,⁹⁹⁴ that the counterclaim defendant had disregarded a federal registration covering the counterclaim plaintiff’s mark “by commencing operations under an almost identical service mark for identical services, evidencing [the

⁹⁸⁴ *Id.* at 1246.

⁹⁸⁵ *Id.* at 1243.

⁹⁸⁶ *Id.* at 1244.

⁹⁸⁷ *Id.* at 1245.

⁹⁸⁸ *Id.* at 1246.

⁹⁸⁹ *See* *Mayson-Dixon Strategic Consulting, LLC v. Mason-Dixon Polling & Strategic Consulting, Inc.*, 324 F. Supp. 3d 569 (D. Md. 2018).

⁹⁹⁰ *Id.* at 578.

⁹⁹¹ *Id.*

⁹⁹² *Id.*

⁹⁹³ *Id.*

⁹⁹⁴ *Id.* at 579.

counterclaim defendant’s] intent to confuse the public,” and that the counterclaim defendant’s partisan client base threatened the counterclaim plaintiff’s reputation for nonpartisan services.⁹⁹⁵ The counterclaim defendant convinced the court to discount two instances of actual confusion proffered by the counterclaim plaintiff as de minimis,⁹⁹⁶ as well as that the parties’ clients and potential clients were sophisticated,⁹⁹⁷ but those showings did not affect the court’s ultimate conclusion that “the [counterclaim defendant’s] use of the MAYSON-DIXON Mark is a classic example of blatant trademark infringement.”⁹⁹⁸

Preliminary injunctive relief also issued in a trade dress dispute between two confectioners using allegedly confusingly similar packages for their lollipops.⁹⁹⁹ The plaintiff’s package appears below on the left, while that of the defendant, introduced approximately six years later, appears on the right:¹⁰⁰⁰



Addressing the similarity between the packages, the court found that:

While the appearance of the two bags are undoubtedly similar when viewed side-by-side, that is not the question here. Instead, viewing the Charms Mini Pops bag alone, it is clear from the prominent display of the recognizable “Charms” house mark that the two bags are sufficiently dissimilar. Even if the resemblance incites some association

⁹⁹⁵ *Id.*

⁹⁹⁶ *Id.*

⁹⁹⁷ *Id.*

⁹⁹⁸ *Id.* at 580.

⁹⁹⁹ See Spangler Candy Co. v. Tootsie Roll Indus., 372 F. Supp. 3d 588 (N.D. Ohio), *appeal dismissed*, No. 19-3227, 2019 WL 2564576 (6th Cir. May 10, 2019).

¹⁰⁰⁰ *Id.* at 593.

with Dum Dums, the Charms house mark strongly reduces the likelihood of confusion for purposes of this factor.¹⁰⁰¹

Especially in light of the “rather weak” nature of the plaintiff’s trade dress¹⁰⁰² and the plaintiff’s failure to introduce evidence of actual confusion,¹⁰⁰³ such a finding might well have disposed of the plaintiff’s request for the extraordinary remedy of a preliminary injunction, but the court ultimately found the plaintiff’s motion well-founded, largely on the basis of the low degree of care exercised by purchasers of the parties’ goods¹⁰⁰⁴ and what the court viewed as the defendant’s bad-faith copying of the plaintiff’s package.¹⁰⁰⁵ With respect to the latter consideration, the court found that “[the defendant] not only recognized the similarity in [its] color scheme and proceeded to use the design anyway, but also acted with the intent that the two bags sit side-by-side in the market place,”¹⁰⁰⁶ that the defendant had not bothered to make its prices more competitive while using its old packaging,¹⁰⁰⁷ and that “the product redesign process used by [the defendant] did not consist of market research and was complete in a quarter of the time [the plaintiff] used to redesign [its] trade dress years prior.”¹⁰⁰⁸ Because “[the plaintiff] has proven success on the merits is not merely possible, but likely,” a preliminary injunction was appropriate.¹⁰⁰⁹

That was not the only dispute to produce a preliminary injunction against the alleged copying of packaging, as another court found confusion likely between the following pancake packages on the top row (used by the plaintiff) and that on the bottom row (used by the defendants):¹⁰¹⁰

¹⁰⁰¹ *Id.* at 605 (citation omitted).

¹⁰⁰² The court’s finding on this issue rested on third-party use of red bags throughout the candy industry generally and the absence of any evidence the plaintiff had ever emphasized its packaging in its advertising. *Id.* at 604.

¹⁰⁰³ The plaintiff did not adduce anecdotal evidence of actual confusion, and the court found its survey evidence entitled only to “little or no weight.” *Id.* at 601.

¹⁰⁰⁴ *Id.* at 606.

¹⁰⁰⁵ *Id.* at 606-07.

¹⁰⁰⁶ *Id.* at 606.

¹⁰⁰⁷ *Id.*

¹⁰⁰⁸ *Id.* at 607.

¹⁰⁰⁹ *Id.*

¹⁰¹⁰ See *Kodiak Cakes LLC v. Cont’l Mills, Inc.*, 358 F. Supp. 3d 1219, 1225 (D. Utah 2019).

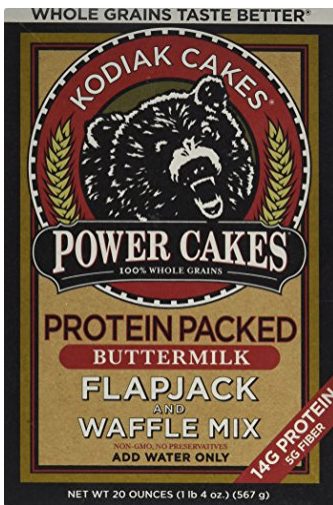

The plaintiff put the defendants into a proverbial bear hug based in large part on the “obviously similarity between the two companies’ packaging,” which the court considered evidence of the defendants’ bad-faith copying of the plaintiffs’ design;¹⁰¹¹ the court found additional evidence of that intent in the defendants’ abrupt transition to their package after years of using a distinguishable one and after commissioning market research on the success of the plaintiff’s goods.¹⁰¹² The plaintiff also benefitted from its anecdotal evidence of actual confusion, which included instances of mistaken purchasing decisions and in response to which the defendant

¹⁰¹¹ *Id.* at 1231.

¹⁰¹² *Id.*

submitted survey evidence rejected by the court.¹⁰¹³ There was no stopping the plaintiff from that point forward, as the likelihood of confusion between the packages was increased by the directly competitive nature of the parties' goods,¹⁰¹⁴ the parties' use of the same retailers,¹⁰¹⁵ the possibly low degree of care exercised by purchasers,¹⁰¹⁶ and the conceptual and commercial strength of the plaintiff's trade dress.¹⁰¹⁷

An allegation of intentional copying also produced results in an action to protect the MoMA mark, which the plaintiff had registered for "a variety of goods and services, such as stationery, arts and crafts, household items, games, artwork reproductions, books, clothing, other general merchandise, entertainment and art services, and museum services";¹⁰¹⁸ the plaintiff also established to the court's satisfaction that it enjoyed common-law rights to the same mark for the sale of foods and beverages. The preliminary injunction record established that the plaintiff used the mark both horizontally and vertically, sometimes using a proprietary font developed specifically for it.¹⁰¹⁹

¹⁰¹³ *Id.* at 1231-33.

The court's objections to the defendants' survey evidence took two forms: (1) "a look at the raw data shows that 28% of respondents believed that [the plaintiff] was the source of the [defendants'] protein mix and 42.4% of respondents believed there was some relation between the two pancake mixes," *id.* at 1233; and (2) commentary by some respondents questioned the lawfulness of the defendants' packaging. *Id.*

¹⁰¹⁴ *Id.*

¹⁰¹⁵ *Id.*

¹⁰¹⁶ *Id.* at 1234.

¹⁰¹⁷ *Id.* at 1234-35.

With respect to conceptual strength, the court found the plaintiff's packages "arbitrary." *Id.* at 1228. It then weighed the packages' commercial strength by referring to the Tenth Circuit's factors for evaluating claims of acquired distinctiveness, namely: "(1) the length and manner of the mark's use, (2) the nature and extent of advertising and promotion of the mark, and (3) the efforts made to promote a conscious connection, in the public's mind, between the mark and a particular product." *Id.* at 1234.

¹⁰¹⁸ See *Museum of Modern Art v. MOMACHA IP LLC*, 339 F. Supp. 3d 361, 373 (S.D.N.Y. 2018).

¹⁰¹⁹ *Id.* at 369-70.

MOMA



For their part, the defendants operated an art gallery and café under the MOMOCHA mark, which they displayed in the format shown in the top row below before transitioning to the format shown in the bottom row:¹⁰²⁰



At the time of the plaintiff's motion, however, the defendants continued to use the old format of their mark on social media and cups.

¹⁰²⁰ *Id.* at 371.

The court held the plaintiff's request for preliminary injunctive relief meritorious. Although the plaintiff's mark was descriptive for its primary services, it was arbitrary for the sale of food and beverages; moreover, and in any case, the plaintiff's long-standing use and promotion of its mark rendered the mark commercially strong.¹⁰²¹ Comparing the parties' respective uses, and despite the defendants' attempted reliance on disclaimers of affiliation, the court found that the defendants' original uses were "highly similar" to the plaintiff's mark, especially in light of the defendants' apparent copying of the plaintiff's proprietary font, and even the new presentation of their mark continued to have at least "some similarities."¹⁰²² It then determined that the competitive proximity of the parties' services favored a finding of liability even though the plaintiff's retail operations sold prints and reproductions of art while the defendants sold only original artwork.¹⁰²³ The plaintiff's introduction of "multiple anecdotal instances of actual confusion" similarly met with judicial favor,¹⁰²⁴ as did its argument that "[i]t is more likely than not that [the defendants] intentionally copied the [plaintiff's] mark in bad faith when [they] adopted [their] old logo."¹⁰²⁵ Finally, because "[t]he cost of viewing art in galleries and

¹⁰²¹ *Id.* at 375.

¹⁰²² *Id.* at 377.

The court elaborated on this point with the following observations:

First, the dominant features (strong block letters in black-and-white coloring) remain the same. Second, although the change eliminates the "MoM" capitalization similarity, the capitalization of "CHA" creates another similarity with some of the [plaintiff's] satellite locations. MoMA QNS [a variation on the plaintiff's mark used in Long Island City] and MoMA PS1 [another variation], for example, both consist of the letters "MoMA" followed by three characters with all of its letters capitalized. It would thus not be unreasonable for someone to believe that "MOMACHA" is another one of the [plaintiff's] satellite locations, despite the capitalized "O" and lack of a space between "MOMA" and "CHA."

Id. at 376.

¹⁰²³ *Id.* at 378.

¹⁰²⁴ *Id.* That evidence consisted of an e-mail from an attorney who thought the presentations of the parties' marks were sufficiently similar that he needed to confirm whether the parties were affiliated and "social media posts by consumers who believed that [the defendants'] beverages are affiliated with the [plaintiff]." *Id.* at 378-79.

¹⁰²⁵ *Id.* at 379.

Seeking to establish their good faith, the defendants argued that they had retained outside trademark counsel to opine on the availability of their MOMACHA mark. The court, however, discounted that argument, holding:

That [the defendants] retained counsel to give advice and conduct a trademark search to ensure that the word mark "MOMACHA" did not conflict with any registered trademarks would indicate that MOMACHA acted in good faith, were it not for the fact that in applying to register the word mark "MOMACHA," [the defendants] also applied to register the word mark "MOMA," the exact same mark as that of the plaintiff].

Id. (citation omitted).

museums is relatively low,”¹⁰²⁶ the court found that “a significant amount of the [parties’] visitors are likely to be unsophisticated and unknowledgeable about the art being displayed”;¹⁰²⁷ likewise, “the cost of a beverage is relatively low, and an average consumer of tea or coffee is thus unlikely to be discerning when buying a beverage from either party.”¹⁰²⁸ The plaintiff therefore had established the likelihood of success on the merits to warrant a preliminary injunction.

As that outcome suggests, evidence that a defendant adopted its mark with the intent of diverting sales from a plaintiff to itself can be powerful evidence of likely confusion, but another opinion made clear that such evidence is not necessary to the grant of a preliminary injunction motion.¹⁰²⁹ The lawsuit producing that opinion was brought by the Colorado-based owner of the CENTRAL BANK & TRUST mark for banking services against three Missouri-based defendants after they opened a branch of their own bank in the state under the CENTRAL BANK mark. After finding that the proposed preliminary injunction was a disfavored “mandatory” one,¹⁰³⁰ the court required the plaintiff to make a “strong showing” that it was likely to prevail on the merits of its infringement claim, but that requirement ultimately posed no obstacle. Although the parties presented their marks differently in the marketplace, “the marks are identical until one reaches the ‘and Trust’ portion of Plaintiff’s mark—and it is doubtful how often a normal consumer adds the ‘and Trust’ when referring to Plaintiff”;¹⁰³¹ moreover, the court found, “[b]y meaning, the marks are essentially identical.”¹⁰³² The plaintiff also successfully introduced evidence and testimony of “eight uncontroverted instances of actual confusion,”¹⁰³³ which the defendants failed to convince the court were *de minimis* in nature.¹⁰³⁴ Further evidence of liability lay in the competitive

¹⁰²⁶ *Id.* at 380.

¹⁰²⁷ *Id.*

¹⁰²⁸ *Id.*

¹⁰²⁹ *See* Cent. Bancorp, Inc. v. Cent. Bancompany, Inc., 385 F. Supp. 3d 1122 (D. Colo. 2019).

¹⁰³⁰ *Id.* at 1136 (“Although Plaintiff nominally seeks an injunction only prohibiting the use of the word ‘Central’ as part of Defendants’ bank branding in Colorado, this amounts to a mandate that Defendants change their signage, uniforms, letterhead, and so forth.”).

¹⁰³¹ *Id.* at 1140.

¹⁰³² *Id.*

¹⁰³³ *Id.* at 1141.

¹⁰³⁴ According to the court, “a defendant may not fall back on the concept of *de minimis* confusion unless “(1) the trademarked product and the defendant’s product are not physically similar or are not used for similar purposes, or (2) the defendant has put on its own substantial evidence demonstrating no significant actual confusion—for example, testimony from consumers stating that they were not confused.” *Id.* (quoting *Beltronics USA, Inc. v. Midwest Inventory Distribution, LLC*, 562 F.3d 1067, 1076 (10th Cir. 2009)). Neither exception applied.

proximity of the parties' services and the fact that, "most consumers do not expect to find two banks with—from their perspective—precisely the same name in the same city,"¹⁰³⁵ regardless of "whatever amount of care banking customers normally exercise."¹⁰³⁶ And, with respect to the defendants' intent, the court found:

[T]he Court finds it appropriate to consider under this factor Defendants' due diligence, or lack thereof. Both Defendants' general counsel [and] executive vice president of marketing and retail banking . . . testified . . . that they essentially expect to find other "Central" Banks wherever they might expand . . . , and they simply hope to work it out once they get there. [The executive vice president] testified that some amount of confusion usually does result, at least for a short time, when Defendants expand. Thus, although the Court has no evidence that Defendants expanded into Colorado under the "Central Bank" name in hopes of confusing and drawing away Plaintiff's customers, it is nonetheless relevant that Defendants expect that their actions will cause confusion, at least temporarily.¹⁰³⁷

The preliminary injunction record did not uniformly favor the plaintiff's position—the plaintiff's mark was at least conceptually weak, and there was no showing that the parties used overlapping advertising media—but, considered in the aggregate, that record demonstrated a likelihood of confusion between the parties' marks.

(ii) Opinions Finding Likelihood of Confusion as a Matter of Law

The factual scenarios underlying, and procedural dispositions of, some cases lent themselves to findings of likely confusion as a matter of law. That disposition occurred most often in cases in which defendants defaulted in response to the allegations of infringement against them,¹⁰³⁸ but at least some plaintiffs prevailed on motions for summary judgment. For example, the Fifth Circuit did not hesitate to affirm a finding of likely confusion between the following marks, which the plaintiff and the defendant, respectively, used in connection with the promotion of political candidates:¹⁰³⁹

¹⁰³⁵ *Id.* at 1143.

¹⁰³⁶ *Id.*

¹⁰³⁷ *Id.* at 1141.

¹⁰³⁸ *See, e.g., Kohler Co. v. Bold Int'l FZCO*, 127 U.S.P.Q.2d 1459, 1467-79 (E.D.N.Y. 2018) (finding, on plaintiff's uncontested motion for default judgment, likely confusion as a matter of law between THE BOLD LOOK OF KOHLER and BOLD marks, both used for kitchen and bath fixtures), *report and recommendation adopted in relevant part*, No. 17-cv-4233 (LDH) (RLM), 2018 WL 4804655 (E.D.N.Y. Oct. 4, 2018).

¹⁰³⁹ *See Alliance for Good Gov't v. Coal. for Better Gov't*, 901 F.3d 498, 501-502 (5th Cir. 2018).



Seeking to distinguish the parties' composite marks, the defendant feebly claimed that the avian component of the plaintiff's mark was an eagle while that of its own mark was a hawk, but the appellate court concluded that "[w]e agree with the district court: the birds are identical. Whether that bird is a *haliaeetus leucocephalus* (bald eagle), a *buteo jamaicensis* (red-tailed hawk), or some other bird, we need not determine."¹⁰⁴⁰ The plaintiff's case took flight from there, with the court determining that the plaintiff's mark was both conceptually and commercially strong.¹⁰⁴¹ Before the district court, the plaintiff failed to establish the existence of actual confusion or that the parties targeted unsophisticated consumers, but those circumstances were of little import in light of the others that lined up in the plaintiff's favor. Those included the defendant's unexplained adoption of a "striking similar[]" mark, which the court considered evidence of a bad-faith intent in and of itself.¹⁰⁴² the competitive proximity of the parties' services,¹⁰⁴³ the indistinguishable nature of "the outlet and purchaser identity for the two organizations,"¹⁰⁴⁴ the parties' use of the same promotional media,¹⁰⁴⁵ and the defendant's bad-faith intent, which the court held was apparent in the defendant's unexplained adoption of a strikingly similar logo.¹⁰⁴⁶ Nevertheless, the court limited its affirmance to the parties' logos and not their verbal names, which it found on appeal were distinguishable.¹⁰⁴⁷

In a case similarly crying out for a finding of infringement as a matter of law, a group of defendants, apparently believing that marks used by a dissolved subsidiary of the plaintiff had been abandoned, undertook an unapologetic campaign to misappropriate the goodwill associated with those marks.¹⁰⁴⁸ That campaign

¹⁰⁴⁰ *Id.* at 512.

¹⁰⁴¹ *Id.* at 509-10.

¹⁰⁴² *Id.* at 511-12.

¹⁰⁴³ *Id.* at 512.

¹⁰⁴⁴ *Id.*

¹⁰⁴⁵ *Id.*

¹⁰⁴⁶ *Id.* at 512-13.

¹⁰⁴⁷ *Id.* at 513-14.

¹⁰⁴⁸ See *AECOM Energy & Constr., Inc. v. Ripley*, 348 F. Supp. 3d 1038 (C.D. Cal. 2018), reconsideration denied, No. CV 17-5398-RSWL-SSx, 2019 WL 2610953 (C.D. Cal. Apr. 24, 2019), appeal docketed, No. 19-55588 (9th Cir. May 23, 2019).

included the defendants' putative revival of the subsidiary through false corporate filings, their recordation of false change-of-address information against a pair of registrations owned by the subsidiary, their fraudulent procurement of a new registration covering one of the marks, and their establishment of a website accessible at domain names based on the marks, at which they falsely claimed credit for construction projects actually handled by either the plaintiff or the subsidiary. The California federal district court hearing the case referenced the Ninth Circuit's likelihood-of-confusion factors in a footnote,¹⁰⁴⁹ but its disposition of the case boiled down to its conclusion that "Plaintiff has put forth evidence that the marks on Defendants' website are identical and used in the same market to sell the same services and goods, including construction contracts and construction equipment."¹⁰⁵⁰ To the extent it addressed the standard factors expressly, the court found that the strength of the plaintiff's marks, actual confusion in the form of a former employee of the plaintiff's subsidiary contacting one of the defendant corporations while under the impression it was the plaintiff's subsidiary, and the defendants' unmistakable bad faith precluded a factual dispute concerning liability.¹⁰⁵¹

A more detailed application of the Ninth Circuit's likelihood-of-confusion factors led to an equally predictable finding of infringement as a matter of law against a group of defendants who ill-advisedly marketed "off-price" clothing under the VERSACE 19.69 ABBIGLIAMENTO SPORTIVO, S.R.L. mark.¹⁰⁵² The owner of the VERSACE mark and its United States affiliate had little difficulty establishing beyond material dispute that the mark-similarity factor favored their position, especially in light of testimony from an expert retained by the defendants that "Versace" was the dominant element of their mark.¹⁰⁵³ The defendants did not dispute that the parties sold overlapping goods,¹⁰⁵⁴ and the court found the lead plaintiff's marks commercially strong based on the incontestable registrations covering them and the plaintiff's showing that it "has used its marks for decades, undertaken extensive efforts to advertise and promote its branded products, is well-recognized by the general public, and has enjoyed annual revenues of over \$100 million";¹⁰⁵⁵ indeed, the plaintiffs filed

¹⁰⁴⁹ *Id.* at 1052 n.9.

¹⁰⁵⁰ *Id.* at 1052.

¹⁰⁵¹ *Id.* at 1053-54.

¹⁰⁵² See *Gianni Versace, S.p.A. v. Versace 19.69 Abbigliamento Sportivo SRL*, 328 F. Supp. 3d 1007 (N.D. Cal. 2018), *appeal dismissed*, No. 19-15188, 2019 WL 2005744 (9th Cir. Apr. 17, 2019).

¹⁰⁵³ *Id.* at 1015.

¹⁰⁵⁴ *Id.* at 1016.

¹⁰⁵⁵ *Id.*

“statements from [the defendants’] licensees stating that they entered into agreements with [the defendants] precisely because of the value of the Versace name and [the defendants’] association with and use of the word ‘Versace.’”¹⁰⁵⁶ The defendants failed to contest the plaintiffs’ evidence that the parties’ goods were available through the same outlets,¹⁰⁵⁷ and the court rejected their claim of customer satisfaction because “a consumer can have sophisticated taste, but still be confused by products that are similar in look or function.”¹⁰⁵⁸ If these considerations were not enough, the plaintiffs submitted “extensive evidence of consumer confusion and disappointment stemming from the conflation of [the defendants’] and [the plaintiffs’] products,” as well as “[n]egative remarks and product reviews by . . . purchasers [of the defendants’ goods] show[ing] that many understand [the defendants’] products to be manufactured and/or sold by [the plaintiffs].”¹⁰⁵⁹ Finally, the court found the lead defendant had acted in bad faith based on: “(1) [the lead defendant’s] knowledge of the [lead plaintiff’s] marks; (2) [the lead defendant’s] agreement to indemnify licensees against any infringement lawsuit brought by [the plaintiffs]; and (3) [the lead defendant’s] branding and marketing materials, which [the lead plaintiff] argues create a ‘false association’ with its brand.”¹⁰⁶⁰

Summary judgment of infringement also held in an action in which a counterclaim defendant ill-advisedly challenged two applications by a subsidiary of Apple Inc. to register the iPad mark for cloud storage and computing services.¹⁰⁶¹ In an appeal from the Trademark Trial and Appeal Board’s dismissal of the opposition, the counterclaim defendant claimed prior rights to the same mark for web-based software applications for mobile-access database management, but, like the Board before it, the court determined that the counterclaim defendant had failed to establish it enjoyed protectable rights prior to the filing dates of the counterclaim plaintiffs’ applications. That failure opened the door for the counterclaim plaintiffs’ infringement claim, which succeeded as a

¹⁰⁵⁶ *Id.*

¹⁰⁵⁷ *Id.* at 1017-18.

¹⁰⁵⁸ *Id.*

¹⁰⁵⁹ *Id.* at 1019.

Beyond documenting actual confusion among actual customers, the plaintiffs demonstrated to the court’s satisfaction the same phenomenon among potential customers in the form of “online inquiries asking how [the parties’] products are related,” among retailers “mistak[ing] the nature of [the parties’] relationship,” and among media mistakenly attributing one of the defendants’ stores to the plaintiff. *Id.* The plaintiffs apparently also submitted survey results showing that “84 percent of respondents in the test conditions were confused as to source, association, or permission,” *id.*, but the court did not address the survey or its methodology in detail.

¹⁰⁶⁰ *Id.* at 1020.

¹⁰⁶¹ See *RXD Media, LLC v. IP Application Dev.*, 377 F. Supp. 3d 588 (E.D. Va. 2019), *appeal docketed*, No. 19-1461 (4th Cir. Apr. 30, 2019).

matter of law for multiple reasons. Among them was the “undeniabl[e]” strength of Apple’s iPad mark, of which the court remarked that “[Apple’s] products and i-formative trademarks make up one of the most recognizable brands in the world.”¹⁰⁶² The identity of the parties’ marks obviously also favored a finding of liability, as did the parties’ common use of online promotional media and channels of distribution, and the counterclaim defendant’s full awareness of Apple’s rights when adopting its mark.¹⁰⁶³ The clincher, however, was evidence of actual confusion in the form of survey results documenting a net 27 percent rate of confused respondents.¹⁰⁶⁴

An additional finding of likely confusion as a matter of law came in an action to protect the PEPPA PIG mark for cookie cutters in the (federally registered) shape of the fictional porcine ungulate of the same name.¹⁰⁶⁵ Earlier in its opinion, the Illinois federal district court hearing the case had found that the defendants’ misappropriation of the plaintiff’s registered marks rose to the level of counterfeiting, but the court nevertheless gamely went through the Seventh Circuit’s standard multifactored test for mere infringement as well. The results of an application of that test were predictable: Because the defendants had used exact reproductions of the marks in connection with the same goods as those covered by the plaintiff’s registrations, the factors of mark similarity, competitive proximity of goods, and overlap in customer base favored the plaintiff; so too did the strength of its mark, the low degree of care exercised by consumers, and the defendants’ bad faith. Although the defendants faulted the plaintiff for failing to adduce evidence of actual confusion, that consideration did not create a factual dispute as to their liability.¹⁰⁶⁶

A different bid to protect a nontraditional mark met with similar success.¹⁰⁶⁷ That mark was the color orange, of which the plaintiff, a manufacturer of fall protection, had received a registration on the Principal Register that featured the following drawing:

¹⁰⁶² *Id.* at 594-95.

¹⁰⁶³ *Id.* at 597.

¹⁰⁶⁴ *Id.*

The court did not discuss the methodology employed by the counterclaim plaintiffs’ survey.

¹⁰⁶⁵ See *Entm’t One UK Ltd. v. 2012Shiliang*, 384 F. Supp. 3d 941 (N.D. Ill. 2019).

¹⁰⁶⁶ *Id.* at 952.

¹⁰⁶⁷ See *SafeRack, LLC v. Bullard Co.*, 350 F. Supp. 3d 438 (D.S.C. 2018), *report and recommendation adopted*, No. 2:17-cv-1613-RMG, 2019 WL 460699 (D.S.C. Feb. 5, 2019).

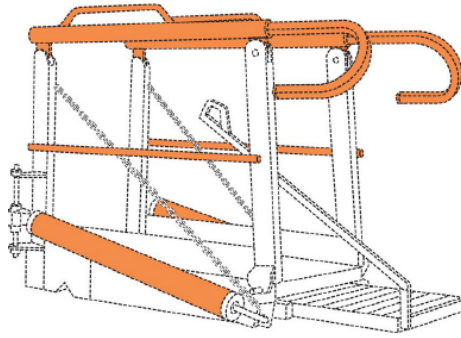

When the defendant displayed competitive equipment featuring another shade of the color at a trade show, the plaintiff pursued a lawsuit, in the course of which the parties filed cross-motions for summary judgment. The defendant attacked the validity of the plaintiff's mark, but, far from finding it generic, as alleged by the defendant, the court concluded the mark was a strong indicator of origin based on its use since 2003, an annual advertising spend by the plaintiff ranging from \$925,000 and \$2,560,000, and "undisputed testimony from multiple consumers that orange on fall protection equipment identified [the plaintiff's] products and, until [the defendant's entry], no competitors who sold similar equipment in its industry used the color orange on fall protection equipment."¹⁰⁶⁸ The defendant similarly failed to convince the court that the parties' uses were distinguishable shades of orange because "[t]he fact that marks may use different shades of the color does not preclude a finding of similarity."¹⁰⁶⁹ Moreover, there was no material dispute that the parties' goods were competitive, targeted toward the same consumers, and promoted through the same media.¹⁰⁷⁰ With the plaintiff able to demonstrate actual confusion in the form of a third-party consumer who, encountering the defendant's goods, thought the defendant was "piggy backing off of [the plaintiff],"¹⁰⁷¹ the defendant's fate was sealed.

Finally, the past year produced the usual reported opinions finding infringement as a matter of law based on the failure of defendants formerly affiliated with a plaintiff to disassociate themselves from that plaintiff.¹⁰⁷² For example, having lost their affiliation with the plaintiff, a national farmers' association, the

¹⁰⁶⁸ *Id.* at 449.

¹⁰⁶⁹ *Id.* at 450.

¹⁰⁷⁰ *Id.* at 451.

¹⁰⁷¹ *Id.*

¹⁰⁷² *See, e.g., City of N.Y. v. Tavern on the Green Int'l LLC*, 351 F. Supp. 3d 680, 695 (S.D.N.Y. 2018) (granting licensor's motion for summary judgment against former licensee based on language in license recognizing presumption of likely confusion in event of breach by licensee).

defendants wound up enjoined from using their CALIFORNIA STATE GRANGE mark.¹⁰⁷³ They responded to the injunction by transitioning to the use of CSG as a substitute mark, which led another affiliate of the lead plaintiff mistakenly to conclude that the defendants remained affiliated with the lead plaintiff. Whether by omission or design, the court did not apply the standard likelihood-of-confusion factors when granting the lead plaintiff's motion for summary judgment; instead, it went straight to the point and held that "defendants' misleading representations of itself [sic] as the 'CSG', which are available on public websites and thus part of interstate commerce, caused confusion and damage to the [lead plaintiff's] reputation."¹⁰⁷⁴

(iii) Opinions Finding Likelihood of Confusion After Trial

An Eighth Circuit opinion demonstrated the deference characteristically afforded by appellate courts to factual findings of infringement made after full trials.¹⁰⁷⁵ The plaintiff in the appeal before that court owned a federal registration of the mark shown below on the left for shot glasses, while the defendants sold shot glasses with the appearance shown on the right.¹⁰⁷⁶

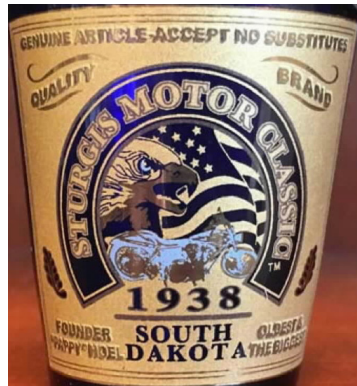

A jury found confusion likely between the two uses, and the appellate court declined to disturb that determination on appeal. The court noted that a factfinder tasked with the infringement

¹⁰⁷³ See *Nat'l Grange of the Order of Patrons of Husbandry v. Cal. Guild*, 334 F. Supp. 3d 1057 (E.D. Cal. 2018), *reconsideration denied sub nom. Nat'l Grange v. Cal. Guild*, No. 2:16-cv-0201 WBS DB, 2018 WL 5270563 (E.D. Cal. Oct. 22, 2018), *appeal docketed*, No. 18-16671 (9th Cir. Sept. 5, 2018).

¹⁰⁷⁴ *Id.* at 1066.

¹⁰⁷⁵ See *Sturgis Motorcycle Rally, Inc. v. Rushmore Photo & Gifts, Inc.*, 908 F.3d 313 (8th Cir. 2018), *on remand*, 129 U.S.P.Q.2d 1392 (D.S.D. 2019).

¹⁰⁷⁶ *Id.* at 338.

inquiry “must” apply the standard multifactored test for likelihood of confusion. At the same time, however, it saw “no reason to foreclose the possibility that in some actions a mark’s owner may rely on a visual inspection, without any corroboration from consumer surveys or examples of actual confusion, to prove there is a likelihood of confusion.”¹⁰⁷⁷ It then elaborated on this point:

If, for example, the purportedly infringing mark appears confusing or deceptive on its face, and relevant consumers do not bring to their purchasing decisions atypical or specialized knowledge, a visual inspection might represent a bare-bones way of proving likely confusion. Otherwise, it would appear beyond the ken of a jury to deduce from a visual examination that has not been informed by direct evidence of consumer associations that a challenged use would likely confuse or deceive the ordinary, prudent consumer.¹⁰⁷⁸

The jury therefore had been within its rights in finding infringement.

The Eleventh Circuit reached the same disposition of an appeal before it, albeit in a case in which the finding of infringement below came after a bench trial, rather than one before a jury.¹⁰⁷⁹ The plaintiff’s mark was GORILLA PLAYSETS, under which it sold children’s outdoor playground equipment, while the defendant sold doorway pull-up bars and various attachable accessories under the GORILLA GYM mark. The plaintiff got off to a promising start in the likelihood-of-confusion inquiry with the court’s conclusion that its suggestive mark was both conceptually and commercially strong, with the latter circumstance attributable to the plaintiff’s long-standing use and “significant nationwide advertising and promotion” of the mark,¹⁰⁸⁰ as well as the absence of relevant third-party uses;¹⁰⁸¹ the plaintiff also benefitted from the Eleventh Circuit’s idiosyncratic rule that incontestably registered marks are strong as a matter of law.¹⁰⁸² Holding that “[e]vidence that ultimate consumers were actually confused deserves ‘special attention,’”¹⁰⁸³ the court credited the plaintiff’s showing that two of the plaintiff’s customers had sought assistance from the defendant and that others had posted on-line inquiries about the compatibility of the parties’ goods.¹⁰⁸⁴ Concluding that “[t]he dominant portion of both

¹⁰⁷⁷ *Id.*

¹⁰⁷⁸ *Id.* at 338-39.

¹⁰⁷⁹ *See* PlayNation Play Sys., Inc. v. Velez Corp., 924 F.3d 1159 (11th Cir. 2019).

¹⁰⁸⁰ *Id.* at 1166.

¹⁰⁸¹ *Id.*

¹⁰⁸² *Id.*

¹⁰⁸³ *Id.* at 1167 (quoting Caliber Auto. Liquidators, Inc. v. Premier Chrysler, Jeep, Dodge, LLC, 605 F.3d 931, 938 (11th Cir. 2010)).

¹⁰⁸⁴ *Id.* at 1167-68.

marks is an image of a large gorilla and the word ‘gorilla,’” the court determined that the district court had not erred in finding the marks similar. With the similarities in the parties’ goods, retail outlets, and advertising also favoring the plaintiff, the district court’s ultimate finding of liability withstood appellate scrutiny,¹⁰⁸⁵ despite the USPTO’s registration of both parties’ marks and the absence of survey evidence proffered by the plaintiff.¹⁰⁸⁶

The Supreme Court of Nebraska adopted a similarly deferential approach to a finding of trade name infringement and deceptive trade practices following a bench trial.¹⁰⁸⁷ The court adopted a broadly worded statement of the likelihood-of-confusion test for liability under state law:

The likelihood of confusion in the use of trade names can be shown by presenting circumstances from which courts might conclude that persons are likely to transact business with one party under the belief they are dealing with another party. If the similarity is such as to mislead purchasers or those doing business with the company, acting with ordinary and reasonable caution, or if the similarity is calculated to deceive the ordinary buyer in ordinary conditions, it is sufficient to entitle the one first adopting the name to relief.

. . . .

Confusion can be of a customer and also those likely to do business with the entity, including wholesalers, banks, utility providers, et cetera.¹⁰⁸⁸

In the final analysis, however, the exact formulation of the test made little difference in light of the parties’ use of DENALI CONSTRUCTION and DENALI HOMES (by the plaintiff) and DENALI CUSTOM BUILDERS (by the defendant): Not only did the parties compete directly in the residential construction field, they operated in overlapping geographic markets, and the plaintiff had submitted at trial “evidence of actual confusion on the part of a potential purchaser . . . , a lumber company, two employees of a furniture store, and a utility provider.”¹⁰⁸⁹

In a resolution of an infringement suit not producing an appellate opinion, a Minnesota federal district court not surprisingly reached a finding of liability after receiving evidence and testimony of the parties’ use of the identical marks for directly

¹⁰⁸⁵ *Id.* at 1168-69.

¹⁰⁸⁶ As the court explained with respect to the second of these considerations, “[l]ack of survey evidence does not weigh against the plaintiff when determining likelihood of confusion.” *Id.*

¹⁰⁸⁷ See *Denali Real Estate, LLC v. Denali Custom Builders, Inc.*, 926 N.W.2d 610 (Neb. 2019).

¹⁰⁸⁸ *Id.* at 625.

¹⁰⁸⁹ *Id.*

competitive services.¹⁰⁹⁰ Specifically, the plaintiffs and the defendants alike used the 952 LIMO BUS and RENT MY PARTY BUS marks in the Minneapolis party bus market. While under the belief they were the marks' senior users, the defendants argued in a summary judgment motion that confusion was likely as a matter of law. After finding during a bench trial that the plaintiffs enjoyed priority of rights, the court declined to hold the defendants to their earlier representation of likely confusion.¹⁰⁹¹ Nevertheless, the outcome of the court's infringement analysis was the same as the defendants' once had been. In particular, although the plaintiffs' marks were merely descriptive, they had become "moderately strong" in the relevant market, the parties provided the same services under the same marks, the defendants' conduct suggested an intent to confuse the public, and consumers could not be expected to exercise a high degree of care.¹⁰⁹² It might be true, the court noted, that the plaintiffs had failed to adduce evidence or testimony of actual confusion, but that failure was potentially attributable to the limited scope of the defendants' use of their marks.¹⁰⁹³ And so it found the defendants liable for infringement.

Findings of infringement also resulted from a jury trial before a California federal district court.¹⁰⁹⁴ The plaintiff successfully urging those findings used the REAL CALLER and REAL CALLER ID marks for a caller identification application for smartphones, while its opponents used the REEL CALLER mark for a directly competitive product. Not surprisingly, the court declined to grant the defendants the extraordinary relief of a new trial based on their argument that the plaintiff had failed to introduce any evidence supporting its claims of likely confusion. In rejecting the defendants' post-trial attacks on the jury's finding of infringement, the court observed, "Plaintiff presented evidence of a likelihood of confusion, although this element was largely self-evident. Throughout trial the Court repeatedly sought clarification about whether parties were referring to 'real' or 'reel' caller, and the Court's staff worked

¹⁰⁹⁰ See *Safeway Transit LLC v. Disc. Party Bus, Inc.*, 334 F. Supp. 3d 995 (D. Minn. 2018), *appeal docketed*, No. 18-2990 (8th Cir. Sept. 17, 2018).

¹⁰⁹¹ According to the court:

[The defendants'] admission [of likely confusion] must be understood in the context of [the defendants'] legal position that [they] and not [the plaintiffs] [were] the senior user[s] of the terms at issue and that consumers associated the terms with [the defendants'] services rather than [the plaintiffs']. The fact that the Court now rejects [the defendants'] position on ownership of the marks does not strip away the context of its previous admission.

Id. at 1006.

¹⁰⁹² *Id.* at 1006-07.

¹⁰⁹³ *Id.* at 1007.

¹⁰⁹⁴ See *Talent Mobile Dev., Inc. v. Headios Grp.*, 382 F. Supp. 3d 953 (C.D. Cal. 2019), *appeal docketed*, No. 19-55258 (9th Cir. Mar. 5, 2019).

diligently to create an accurate record despite the obvious confusion these words create.”¹⁰⁹⁵ Although it might be true that the jury also had found confusion unlikely between logos used by the parties, that did not mandate the same conclusion with respect to the parties’ word marks.¹⁰⁹⁶

A final notable finding of likely confusion following a bench trial came in a rare appeal from an opinion of the Trademark Trial and Appeal Board in which claims or counterclaims of infringement were not joined.¹⁰⁹⁷ The plaintiff’s mark was VAGISIL for personal care products, while the defendant had applied to register the VAGISAN mark for directly competitive goods. The Board dismissed the plaintiff’s opposition to the defendant’s application, which led the plaintiff to pursue a district court appeal before the U.S. District Court for the Eastern District of Virginia, where it had better luck.

The plaintiff’s first victory on appeal took the form of the court’s holding that it would not take into account marketplace considerations in the likelihood-of-confusion inquiry. Before applying the Fourth Circuit’s standard nine-factor test in the infringement context, the court noted:

Before proceeding to apply these factors, it is important to resolve the parties’ threshold dispute whether the likelihood of confusion analysis in this [Section 21(b)] action should be based on the VAGISAN mark as depicted and described in the application or as used in the marketplace. Plaintiff’s argument is correct; because this case involves only the issue whether defendant’s mark, VAGISAN, is registrable, the likelihood of confusion factors must take into account only the depiction and description of the VAGISAN mark contained in defendant’s application to register the mark, not defendant’s actual use of VAGISAN in the marketplace.¹⁰⁹⁸

Specifically, “in a registration opposition proceeding before the TTAB, the likelihood of confusion analysis considers only ‘the mark as shown in the application and as used on the goods described in the application . . . not the mark as actually used.’”¹⁰⁹⁹

Although thus adopting the Board’s approach to determining whether the parties’ marks were confusingly similar, the court found the Board had erred by concluding they were not. One reason for that was the conceptual and commercial strength of the plaintiff’s mark, which was reflected in the mark’s

¹⁰⁹⁵ *Id.* at 962.

¹⁰⁹⁶ *Id.*

¹⁰⁹⁷ *See Combe Inc. v. Dr. August Wolff GmbH & Co. KG Arzneimittel*, 382 F. Supp. 3d 429 (E.D. Va. 2019), *appeal docketed*, No. 19-1674 (4th Cir. June 24, 2019).

¹⁰⁹⁸ *Id.* at 444.

¹⁰⁹⁹ *Id.* (quoting *B & B Hardware, Inc. v. Hargis Indus.*, 135 S. Ct. 1293, 1307 (2015)).

suggestiveness,¹¹⁰⁰ the “considerable commercial success” of goods sold under it,¹¹⁰¹ the “command[ing]” market position of those goods,¹¹⁰² the “widespread advertising and unsolicited media attention” they had received, which included mentions in episodes of *Saturday Night Live*, *South Park*, and *The Big Bang Theory*,¹¹⁰³ and favorable survey results, namely, a “38.7% level of unaided awareness and [an] 85% rate of net aided recognition”;¹¹⁰⁴ the defendant’s proffer of third-party uses of allegedly similar marks and attacks on the survey’s methodology did little to diminish the plaintiff’s showing.¹¹⁰⁵ The plaintiff also successfully demonstrated the marks themselves were similar, citing the standard-character format in which they appeared in the parties’ filings in the USPTO,¹¹⁰⁶ as well as the facts that “[b]oth marks consist of ‘Vagis’, then a vowel, and then a consonant”¹¹⁰⁷ and that “[b]oth VAGISIL and VAGISAN connote the vaginal area.”¹¹⁰⁸ Turning to the

¹¹⁰⁰ *Id.* at 448-49.

¹¹⁰¹ *Id.* at 449.

¹¹⁰² *Id.* at 450.

¹¹⁰³ *Id.*

¹¹⁰⁴ *Id.* at 451. The court summarized the survey’s methodology in the following manner:

In the unaided portion of the survey, respondents were asked to list all brands of vaginal care products that they had ever seen or heard of. In total, 38.7% of all respondents named VAGISIL in this unaided portion of the survey. VAGISIL was named more frequently than any other brand, with SUMMER’S EVE being named the second greatest number of times by 26% of all respondents.

Next, in the aided portion, respondents were shown a total of eight brand names, one at a time and in random order, and were asked whether or not they had ever seen or heard of the name in connection with any vaginal care product. The brand names shown to respondents in this portion included VAGISIL; other well-known brands MONISTAT and SUMMER’S EVE; lesser-known brands REPLENS, LUVENA, SWEET SPOT, and VAGI-GARD; and a fictitious brand VAGIZOX, which served as the control. In total, VAGISIL was recognized by more respondents than any other brand name shown in the survey, with 90% of all respondents recognizing VAGISIL. Only 5.3% of respondents stated they had seen or heard of the control, VAGIZOX, in connection with any vaginal care product. Accordingly, the Fame Survey reported a net awareness rate of 85% for VAGISIL; that is, it reflected that 85% of respondents recognized VAGISIL specifically because of the mark’s fame and not because of other factors.

Id. at 438-39 (paragraph numbering omitted) (footnote omitted).

¹¹⁰⁵ *Id.* at 451-55.

¹¹⁰⁶ As the court noted, “because both marks are registered as standard character marks, which do not limit the marks to any particular appearance or stylization in commerce, the manner in which the VAGISIL and VAGISAN marks are currently displayed to consumers in the marketplace does not influence the similarity factor in this registrability determination.” *Id.* at 456.

¹¹⁰⁷ *Id.*

¹¹⁰⁸ *Id.* at 457.

The defendant attempted to contest this factor by arguing that “the ‘vagi-’ prefix that is common to both VAGISIL and VAGISAN is weak, and thus consumers will distinguish the terms based on minor differences in the non-common components of the marks,” *id.*, but the court rejected that argument for three reasons. “First,” it held, “this argument

competitive proximity of the parties' goods, the court predictably found that "the registrations for VAGISIL and registration application for VAGISAN reflect that certain goods covered by the parties' marks are identical, such as vaginal moisturizers and vaginal washes."¹¹⁰⁹ It next concluded the parties' channels of distribution and advertising media were similar based on the parties' unrestricted filings¹¹¹⁰ before crediting survey evidence documenting a net 19 percent confusion rate among respondents.¹¹¹¹ The plaintiff did not accuse the defendant of bad faith,¹¹¹² and the trial record was bare of evidence or testimony conclusively establishing the quality of the parties' goods¹¹¹³ or the sophistication of their consumers,¹¹¹⁴ but "the evidence [otherwise] compels the conclusion that defendant's VAGISAN mark is not registrable and that the ruling of the TTAB dismissing plaintiff's opposition to defendant's application to register the VAGISAN mark must be reversed."¹¹¹⁵

(iv) Opinions Finding No Likelihood of Confusion on Motions for Preliminary Injunctive Relief

The past year produced a dearth of reported opinions denying plaintiffs' bids for preliminary injunctions and temporary restraining orders. Nevertheless, there were exceptions to that general rule,¹¹¹⁶ with one coming in a suit against Amazon by a supplier of linens and bedding to luxury spas.¹¹¹⁷ According to the plaintiff, Amazon infringed the plaintiff's COMPHY mark by

conflicts with the 'anti-dissection' rule that the Fourth Circuit has adopted with respect to analyzing the similarity of marks." *Id.* "Second, courts that have held that consumers were likely to differentiate between marks based on minor differences reached that result based on the existence in the marketplace of multiple marks including the same descriptive component for similar goods." *Id.* Finally, "the other cases cited by defendant that concluded there was no likelihood of confusion between marks containing the same so-called 'descriptive prefix' are inapposite here because the marks at issue in those cases contained non-common components that were sufficient to make the marks as a whole dissimilar." *Id.* at 458.

¹¹⁰⁹ *Id.* at 459.

¹¹¹⁰ *Id.*

¹¹¹¹ *Id.* at 462.

¹¹¹² *Id.* at 459-60.

¹¹¹³ *Id.* at 465-66.

¹¹¹⁴ *Id.* at 466.

¹¹¹⁵ *Id.* at 467.

¹¹¹⁶ *See, e.g., Emanuel Mizrahi, DDS, P.C. v. Angela Andretta, DMD, P.C.*, 97 N.Y.S.3d 273, 277 (N.Y. App. Div. 2019) (vacating trial court's sua sponte preliminary injunction in dispute between users of FOREST HILLS ORTHODONTIC ASSOCIATES and FOREST HILLS ORTHODONTICS marks and concluding without explanation that "[t]he evidence at this stage further fails to demonstrate that the plaintiff possesses a likelihood of success on the merits").

¹¹¹⁷ *See Comphy Co. v. Amazon.com, Inc.*, 371 F. Supp. 3d 914 (W.D. Wash. 2019).

purchasing keyword advertising from various search engines so that members of the public searching for terms similar the mark were directed to Amazon's website. The plaintiff additionally complained that individuals entering "comph" in the search bar on that site received options reading "comphy sheets," "comphy company sheets," and "comphysheets," even though the site did not offer the plaintiff's goods for sale.¹¹¹⁸ In further support of its case, the plaintiff argued Amazon's practices had caused the plaintiff to miss its sales targets.¹¹¹⁹

The court, however, did not reach the plaintiff's allegations of damage because it rejected the plaintiff's claim of likely confusion in the first instance. One basis of that disposition was the weakness of the plaintiff's mark, which the court found established by the mark's descriptiveness,¹¹²⁰ the fact that the plaintiff's market standing and advertising was limited to the hospitality sector,¹¹²¹ and the results of a survey commissioned by Amazon disclosing that "thirteen-percent of consumers regarded COMPHY as referring to a particular source for bedding, but that more than twelve-percent of those consumers also regarded 'comfort'—a non-existent company also presented—as also referring to a particular source for bedding."¹¹²² Amazon also benefitted from its successful showing of good faith, despite the plaintiff's allegation that Amazon's past solicitation of the plaintiff as a potential advertiser proved the contrary.¹¹²³ The plaintiff scored a few points in support of its case, namely, that both parties sold bedding (discounted because of the weakness of the plaintiff's mark),¹¹²⁴ that both used keyword advertising (discounted because the plaintiff relied more on word-of-mouth advertising),¹¹²⁵ and that "compelling" evidence of actual confusion existed in the form of reviews on Amazon's site referencing the plaintiff's goods and declaration testimony of a mistaken purchasing decision,¹¹²⁶ but those showings ultimately failed to carry the day.¹¹²⁷

¹¹¹⁸ *Id.* at 919.

¹¹¹⁹ *Id.* at 920.

¹¹²⁰ *Id.* at 924.

¹¹²¹ *Id.* at 925.

¹¹²² *Id.* at 926.

¹¹²³ *Id.* at 928.

¹¹²⁴ *Id.* 926-27.

¹¹²⁵ *Id.* at 927.

¹¹²⁶ *Id.*

¹¹²⁷ *Id.* at 928.

**(v) Opinions Finding No Likelihood of Confusion
as a Matter of Law**

Findings of nonliability for infringement based on plaintiffs' failure to state claims were characteristically infrequent, but they did occur.¹¹²⁸ For example, the Fifth Circuit rather unusually reached a holding of nonliability as a matter of law on its own initiative and without the benefit of a lower court opinion on the issue.¹¹²⁹ The plaintiff appealing to that court was an education-services company specializing in promoting literacy among low-income and English-as-a-second-language students, and it had successfully registered the READ A MILLION WORDS, MILLION DOLLAR READER, MILLIONAIRE READER, and MILLIONAIRE'S READING CLUB for its services and related promotional goods. When the defendant, the largest public school district in Texas, launched a monetary-themed literacy program featuring arguably similar incentives under the HOUSTON ISD MILLIONAIRE CLUB mark, the plaintiff filed suit, only to lose on summary judgment after the district court concluded the defendant had not used the challenged mark in commerce as required by the plaintiff's causes of action.

On the defendant's appeal, the Fifth Circuit affirmed the summary dismissal of the plaintiff's case, but it did so after its review of the record established to its satisfaction that confusion was unlikely as a matter of law. That outcome was heavily influenced by the lack of competition between the parties: While the plaintiff marketed its services to school districts, the defendant *was* a school district. With the plaintiff unable to advance the "nonsensical" argument that the defendant had "confused itself into developing its own literacy program thinking it was instead purchasing [the plaintiff's] program,"¹¹³⁰ its briefs alluded to "alternative [theories] of confusion."¹¹³¹ One was that the defendant's students and their parents might mistakenly believe the defendant used the plaintiff's program rather than its own, a contention the court rejected because "absent any evidence that [the defendant's] students or their parents exercise any influence over [the defendant's] purchasing decisions, we need not consider the likelihood that [the defendant's] students and parents were confused about [the plaintiff's] role in the [defendant's] Millionaire

¹¹²⁸ See, e.g., *Thousand Island Park Corp. v. Welsler*, 314 F. Supp. 3d 391, 398-97 (N.D.N.Y. 2018) (finding that exhibits attached to plaintiff's complaint demonstrated that defendant's allegedly unauthorized use of plaintiff's mark was, in fact, authorized).

¹¹²⁹ See *Springboards to Educ., Inc. v. Hous. Indep. Sch. Dist.*, 912 F.3d 805 (5th Cir. 2019), *as revised* (Jan. 29, 2019), and *as revised* (Feb. 14, 2019).

¹¹³⁰ *Id.* at 813.

¹¹³¹ *Id.*

Club initiative.”¹¹³² Another was that the plaintiff’s goodwill would suffer if the defendant’s services were inferior to those of the plaintiff, which the court took more seriously.

Addressing the second of the plaintiff’s theories, namely, that confusion was likely in the post-sale confusion context, the court turned to its standard multifactored test for infringement. It concluded that, although the plaintiff’s MILLION DOLLAR READER, MILLIONAIRE READER, and MILLIONAIRE’S READING CLUB were suggestive, they were nevertheless commercially weak; the same was true of the READ A MILLION WORDS mark, which was merely descriptive and, like the other marks plagued by third-party use of similar designations.¹¹³³ Other factors favoring the defendant included the parties’ dissimilar promotional strategies,¹¹³⁴ the defendant’s good faith in adopting its mark,¹¹³⁵ and the degree of care exercised by school districts when purchasing the plaintiff’s services.¹¹³⁶ The plaintiff might reasonably have expected to benefit from what the court described as the “commonalities between the marks,” but the court instead held that “the use of identical dominant words does not automatically equate to similarity between marks,”¹¹³⁷ which rendered the mark-similarity factor neutral. In the face of these considerations, no factual dispute as to the defendant’s liability was created by the close similarity between the defendant and the plaintiff’s customers,¹¹³⁸ the relationship between the parties’ or the plaintiff’s showing of four instances of alleged actual confusion among individuals with no authority to purchase the plaintiff’s services.¹¹³⁹

If sponte findings of nonliability on appeal were relatively infrequent, the same was not true where defense motions for summary judgment were concerned. The Eleventh Circuit led the charge at the appellate level in affirming a finding as a matter of law that the “gently sloped ‘s’-shaped line” running upward from the

¹¹³² *Id.*

¹¹³³ *Id.* at 814-15.

¹¹³⁴ *Id.* at 816.

¹¹³⁵ *Id.* at 816-17.

¹¹³⁶ *Id.* at 817.

¹¹³⁷ *Id.* at 815 (quoting *Sensient Techs. Corp. v. SensoryEffects Flavor Co.*, 613 F.3d 754, 765 (8th Cir. 2010)).

¹¹³⁸ Although concluding that this factor might receive “modest weight” in favor of the plaintiff, the court itself discounted it because “[t]his digit is an awkward fit to the facts of the case as [the defendant] did not market the Houston ISD Millionaire Club and therefore had no retail outlets or purchasers.” *Id.* at 816.

¹¹³⁹ Of the four allegedly confused individuals, two were not educators, and one who was testified that she thought the defendant’s literacy program had “nothing to do with [the plaintiff].” *Id.* at 817.

points at which the hulls of the following watercraft intersected with their bows were not confusingly similar.¹¹⁴⁰



The summary judgment record demonstrated that the parties competed in “the same niche market” for the same customers,¹¹⁴¹ and the plaintiff argued that the status of the lead defendant’s principal as a former employee of the plaintiff placed the defendants’ intent into dispute. The court agreed with the defendants, however, that there was an absence of evidence or testimony indicating the defendants had acted with a bad-faith intent to deceive. Plus, numerous other of the relevant likelihood-of-confusion factors stacked up in the defendants’ favor, including third-party use of similar designs that rendered the plaintiff’s trade dress weak,¹¹⁴² the parties’ use of distinguishable logos,¹¹⁴³ the sophistication of their customers,¹¹⁴⁴ and the absence of post-sale confusion.¹¹⁴⁵ The district court therefore had not erred in its summary disposition of the plaintiff’s claims.

The Sixth Circuit similarly affirmed the grant of a defense motion for summary judgment in a dispute arising in the jewelry industry.¹¹⁴⁶ The counterclaim plaintiff claimed rights to the unregistered ARTISTRY, LTD. mark, which it used in connection with the wholesale purchase of jewelry pieces from manufacturers and the resale of those goods to retailers. Its battle with the counterclaim defendant began when that party launched direct sales to consumers of goods branded with the ARTISTRY DIAMONDS and ARTISTRY DIAMOND COLLECTION marks. In affirming the defendant’s victory before the district court, the court identified “two basic problems” with the counterclaim plaintiff’s theory of infringement.¹¹⁴⁷ The first implicated the weakness of the counterclaim plaintiff’s mark,¹¹⁴⁸ the perceived disconnect between

¹¹⁴⁰ See *Yellowfin Yachts, Inc. v. Barker Boatworks, LLC*, 898 F.3d 1279, 1287 (11th Cir. 2018).

¹¹⁴¹ *Id.* at 1292.

¹¹⁴² *Id.* at 1290-91.

¹¹⁴³ *Id.* at 1291.

¹¹⁴⁴ *Id.* at 1292, 1296.

¹¹⁴⁵ *Id.* at 1294-97.

¹¹⁴⁶ See *Sterling Jewelers, Inc. v. Artistry Ltd.*, 896 F.3d 752 (6th Cir. 2018).

¹¹⁴⁷ *Id.* at 756.

¹¹⁴⁸ Citing third-party use of “Artistry” marks in the industry, the court concluded from the summary judgment record that “[the plaintiff’s mark] is a weak mark, one that differs

the counterclaim plaintiff's services and the goods sold by the counterclaim defendant,¹¹⁴⁹ and the differing presentations of the parties' marks as they appeared in the marketplace.¹¹⁵⁰ "That," the court held, "leads to the second problem—the distinct nature of the consumers targeted by each company's set of products—which implicates these four factors: evidence of actual confusion; the marketing channels of each product; the likely degree of purchaser care; and the alleged infringer's intent."¹¹⁵¹ As to those factors, the court determined that inquiries from retailers about the parties' possible affiliation did not constitute actual confusion,¹¹⁵² the parties employed differing marketing channels,¹¹⁵³ and the counterclaim plaintiff's retail customers were "a discerning group of buyers," who, in any case, made big-ticket purchases.¹¹⁵⁴ The counterclaim defendant's intent went unaddressed, but, whatever it may have been, it did not create a factual dispute as to the counterclaim defendant's nonliability.

So too did the Seventh Circuit conclude that a district court had not erred in finding noninfringement as a matter of law despite both parties' use of the CAPSULE mark for cellphone cases.¹¹⁵⁵ Those points of similarity might well have merited a vacatur and remand, especially in light of the court's acknowledgements that "[t]he parties here use 'capsule' in somewhat similar ways,"¹¹⁵⁶ that both parties sold their goods through the same online retailers, and that the parties' goods were "easily available and inexpensive."¹¹⁵⁷ But other factors favored the defendant, including the weakness of the plaintiff's descriptive mark, the lack of prominence with which the parties' packaging displayed the marks, the absence of actual confusion, and the defendant's good faith in adopting its mark.¹¹⁵⁸ The district court therefore had not erred in disposing of the plaintiff's allegations on summary judgment.

at most in modest degree but not in kind from like-seen words and their derivatives in the jewelry business: precious, gorgeous, luxury, vintage, style, forever, creative, crafted, sparkling, exquisite, elegant, and so on." *Id.* at 756.

¹¹⁴⁹ On this issue, the court observed that "[c]onfusion is less likely when companies use their marks to brand different goods and services." *Id.* at 757.

¹¹⁵⁰ *Id.*

¹¹⁵¹ *Id.*

¹¹⁵² Rather than constituting evidence of actual confusion, "questions about potential affiliation confirm that these sophisticated retailers discern a difference between the marks, or at least put themselves in a position to do so." *Id.* at 758.

¹¹⁵³ *Id.* at 757.

¹¹⁵⁴ *Id.* at 758.

¹¹⁵⁵ See *Uncommon, LLC v. Spigen, Inc.*, 926 F.3d 409 (7th Cir. 2019).

¹¹⁵⁶ *Id.* at 426.

¹¹⁵⁷ *Id.*

¹¹⁵⁸ *Id.* at 426-27.

Of course, trial courts also reached findings of nonliability as a matter of law. One such finding came on a summary judgment record that might well have documented a factual dispute on the issue.¹¹⁵⁹ The plaintiff owned a federal registration of the HYP (pronounced either “hip” or “hype”) mark for socks and athletic bras, the rights to which had become incontestable. It objected to the defendants’ use of HYPE SOCKS for socks; when its objections failed to convince the defendants to change their ways, it filed a lawsuit in which the parties filed cross-motions for summary judgment following discovery.

The court denied the plaintiff’s motion and granted that of the defendants. Although the plaintiff’s mark was conceptually strong,¹¹⁶⁰ third-party use narrowed the scope of the protection to which the mark was entitled. Moreover, the court found, the parties’ presentations of their respective marks outweighed what otherwise would have been the similarity of “the trademarked text” alone:



The plaintiff’s troubles did not end there, for the court found that “[a]pproximately 60-70% of [Plaintiff’s] socks bear licensed logos or characters such as DC Comics superheroes, Star Wars characters, or Nickelodeon characters”;¹¹⁶¹ because “Defendants’ socks, in contrast, are custom-designed for sports teams”¹¹⁶² and because “Defendants’ customer base is coaches who seek specialty designed socks for their sports teams,”¹¹⁶³ the competitive proximity of the parties’ goods and their targeted customers also favored the defendants’ position. Crediting the defendants’ showing that “[t]he parties generally distribute through different channels of trade,”¹¹⁶⁴ the court declined to hold that references to the defendants in the

¹¹⁵⁹ See *Hypnotic Hats, Ltd. v. Wintermantel Enters.*, 335 F. Supp. 3d 566 (S.D.N.Y. 2018).

¹¹⁶⁰ On this factor, the court determined the mark was inherently distinctive because it was either arbitrary or fanciful. *Id.* at 583.

¹¹⁶¹ *Id.* at 586.

¹¹⁶² *Id.*

¹¹⁶³ *Id.*

¹¹⁶⁴ *Id.* at 587.

results of Google searches demonstrated the contrary.¹¹⁶⁵ It then rejected the plaintiff's proffered anecdotal and survey evidence of actual confusion, which it held to be de minimis¹¹⁶⁶ and tainted by methodological errors,¹¹⁶⁷ respectively. Finally, it found no material disputes that the defendants had not acted in bad faith,¹¹⁶⁸ that the defendants' products were not of inferior quality,¹¹⁶⁹ and that the factor of customer sophistication was neutral.¹¹⁷⁰ Considered in the aggregate, the court held, the record demonstrated the defendants' eligibility to prevail as a matter of law.

Another rather improbable summary disposal of a case prior to trial occurred in litigation brought by Disney Enterprises and several of its affiliates.¹¹⁷¹ Those plaintiffs challenged a pair of providers of themed entertainment services, including parties, featuring performers clearly modeled on such Disney-owned characters as Mickey Mouse, Minnie Mouse, Elsa and Anna from *Frozen*, Captain America, the Hulk, and the major characters from the *Star Wars* universe. The defendants promoted their services with promises to deliver such events as "Frozen Theme[d] Parties"¹¹⁷² and a "Star War Episode VII Themed Birthday Party."¹¹⁷³ In addition, they produced during discovery "several dozen largely unsigned" contracts replete with references to the plaintiffs' verbal marks.¹¹⁷⁴

¹¹⁶⁵ In taking that step, the court held that "[w]hile such search results can cause 'confusion . . . due to the ease with which the consumer could return to the search results posted by the search engine, courts in this district have held that so called internet initial confusion requires a showing of intentional deception on the part of the defendant before imposing liability.'" *Id.* at 588 (second alteration in original) (quoting *Strange Music, Inc. v. Strange Music, Inc.*, 326 F. Supp. 2d 481, 492 (S.D.N.Y. 2004)).

¹¹⁶⁶ The plaintiff's anecdotal evidence consisted of two e-mails, both sent from individuals familiar with the plaintiff and, as the court noted, "[n]either recipient accidentally purchased [Defendants'] products under the mistaken belief that they came from [Plaintiff]." *Id.* at 589.

¹¹⁶⁷ The plaintiff's expert conducted a *Squirt*-format sequential array survey, the results of which yielded a net confusion rate of 12.0 percent among respondents generally and a net confusion rate of 21.6 percent among the athletic coaches who were the defendant's primary customers. *Id.* at 590. Because the parties' goods were not in immediate proximity, the court held the survey's format "inappropriate," and it additionally faulted the plaintiff's expert for using leading questions, miscoding responses, exposing respondents to improper "distractors," and selection of a control that generated an inappropriately high level of "noise." *Id.* at 587-90.

¹¹⁶⁸ *Id.* at 591-92.

¹¹⁶⁹ *Id.* at 592.

¹¹⁷⁰ *Id.* at 592-93.

¹¹⁷¹ See *Disney Enters. v. Sarelli*, 322 F. Supp. 3d 413 (S.D.N.Y. 2018), *reconsideration denied*, No. 16 CIV. 2340 (GBD), 2018 WL 5019745 (S.D.N.Y. Sept. 26, 2018).

¹¹⁷² *Id.* at 425.

¹¹⁷³ *Id.* at 426.

¹¹⁷⁴ *Id.*

Coupled with the court's findings that the plaintiffs' marks were strong,¹¹⁷⁵ that combination of circumstances might well have produced findings of infringement as a matter of law, but the opposite result held instead. Although the defendants did not dispute that the costumed characters they supplied were identical or virtually identical to the plaintiffs' characters, the court generously accepted their argument that "many [but presumably not all] of the costumed characters Defendants offer are identified on [their] website using facetious names that are clearly distinct from Plaintiffs' marks."¹¹⁷⁶ With equal credulity, it concluded that "it is plain that theme park guests [viewing Plaintiffs' characters] are in a different market altogether from those looking to hire a costumed character [from Defendants] to appear at a child's birthday party or a corporate event."¹¹⁷⁷ The court then took aim at the plaintiffs' showing of actual confusion, of which it observed, "[t]he only anecdotal 'evidence' Plaintiffs can muster are a handful of instances where [Defendants'] customers referred to the actual names of Plaintiffs' characters in online reviews rather than using the names provided for such characters on [Defendants'] website";¹¹⁷⁸ "none of the customer reviews," it found, "suggest the slightest sign of confusion as to the origin, source, affiliation, or sponsorship of [Defendants'] services, much less confusion likely to produce 'a diversion of sales, damage to goodwill, or loss of control over reputation.'"¹¹⁷⁹ The plaintiffs' evidence of bad faith was similarly deficient, despite the defendants' use of "slightly altered character names," their knowledge of the plaintiffs' prior rights, and their false representations they had complied with the plaintiffs' demand letters.¹¹⁸⁰ Finally, even the allegedly lesser quality of the defendants' services favored the defendants' position,¹¹⁸¹ as did the plaintiffs' failure to establish a factual dispute as to the sophistication of the parties' customers.¹¹⁸²

Although case law arising from disputes between purveyors of alcoholic beverages is relatively pro-plaintiff, one group of defendants escaped liability for trademark and trade dress liability as a matter of law in a case in which both parties sold beer.¹¹⁸³ The plaintiffs registered marks for that beverage—which the plaintiff

¹¹⁷⁵ *Id.* at 433.

¹¹⁷⁶ *Id.* at 434.

¹¹⁷⁷ *Id.* at 435.

¹¹⁷⁸ *Id.* at 436.

¹¹⁷⁹ *Id.* (quoting *LVL XIII Brands, Inc. v. Louis Vuitton Malletier S.A.*, 209 F. Supp. 3d 612, 649 (S.D.N.Y. 2016), *aff'd*, 720 F. App'x 24 (2d Cir. 2017)).

¹¹⁸⁰ *Id.* at 436-37.

¹¹⁸¹ *Id.* at 437-38.

¹¹⁸² *Id.* at 438.

¹¹⁸³ *See Shipyard Brewing Co. v. Logboat Brewing Co.*, 127 U.S.P.Q.2d 1187 (W.D. Mo. 2018).

averred comprised a family of marks—including SHIPWEAR, PUMPKINHEAD ALE, PUMPKINHEAD, MELONHEAD, and APPLEHEAD. The plaintiff averred not only infringement of each of those marks by the defendants' SHIPHEAD mark, but a violation of its trade dress rights as well based on the parties' use of an allegedly similar color scheme and a stylized ship on their cans.¹¹⁸⁴



The plaintiff scored few, if any, points in failing to defeat the defendants' motion for summary judgment. Specifically: (1) its marks and trade dress were commercially weak;¹¹⁸⁵ (2) the parties' respective uses were dissimilar in appearance;¹¹⁸⁶ (3) the parties served different geographic areas;¹¹⁸⁷ (4) contrary to the plaintiffs' argument on the issue, constructive notice of its rights did not necessarily mean that the defendants had adopted their mark in bad faith;¹¹⁸⁸ (5) consumers of the particular beers at issue were "likely to be 'discerning,' sophisticated consumers of craft beer";¹¹⁸⁹ and (6) there was no record evidence of actual confusion.¹¹⁹⁰

A final defense victory on a motion for summary judgment demonstrated that, although differences between marks rarely receive dispositive weight in the likelihood-of-confusion analysis, they can on occasion.¹¹⁹¹ The prevailing defendant in that action was assisted greatly by the admission against interest of a principal of the plaintiffs that he did not consider the parties' logos similar.

¹¹⁸⁴ *Id.* at 1195.

¹¹⁸⁵ *Id.* at 1190-91, 1195.

¹¹⁸⁶ *Id.* at 1191-92, 1195-96.

¹¹⁸⁷ *Id.* at 1193.

¹¹⁸⁸ *Id.* at 1193-94.

¹¹⁸⁹ *Id.* at 1194.

¹¹⁹⁰ *Id.*

¹¹⁹¹ See *Gym Door Repairs, Inc. v. Young Equip. Sales, Inc.*, 331 F. Supp. 3d 221 (S.D.N.Y.), *reconsideration denied*, No. 15-CV-4244 (JGK), 2018 WL 5650004 (S.D.N.Y. Oct. 30, 2018).

Although the plaintiffs attempted to create a factual dispute on the issue of liability by averring that they *did*, in fact, consider the parties’ logos confusingly similar, they failed to support that contention with a record cite. “Therefore,” the court concluded, “the plaintiffs have not presented any evidence that the [defendant’s] logo is confusingly similar to [their] logo.”¹¹⁹²

(vi) Opinions Finding No Likelihood of Confusion After Trial

A bench trial in a battle between two cosmetic companies produced a finding of noninfringement that the Eleventh Circuit declined to overturn as clearly erroneous.¹¹⁹³ The plaintiff owned a federal registration of HARD CANDY as a trademark and a service, which it alleged was infringed by the following uses of the same words on the rear panel and interior of the defendant’s packaging:



As had the district court before it, the Eleventh Circuit considered the subsidiary placement of the words on and in the defendant’s packaging a factor allowing consumers to distinguish between the parties’ respective uses.¹¹⁹⁴ The defendant additionally benefitted from the district court’s finding that it had not acted in bad faith, even if that consideration did not deserve dispositive weight.¹¹⁹⁵ Moreover, the absence of evidence of actual confusion favored affirmative, even though the parties’ marks had coexisted in the

¹¹⁹² *Id.* at 252.

¹¹⁹³ *See Hard Candy, LLC v. Anastasia Beverly Hills, Inc.*, 921 F.3d 1343 (11th Cir. 2019).

¹¹⁹⁴ *Id.* at 1361-62.

¹¹⁹⁵ *Id.* at 1362.

market for a mere eight months.¹¹⁹⁶ The district court's finding that confusion was unlikely between the parties' respective uses therefore was not clearly erroneous.

A bench trial before a Nevada federal district court in a different case between competitors in the alcoholic beverage industry produced a finding of noninfringement in the first instance.¹¹⁹⁷ The parties in that action competed in the market for flavored vodkas, and both sides to the dispute used lips-related images on their labels, with those of the plaintiff shown below on the left and that of the defendants shown on the right:

JOHNNY
LOVE
VODKA



The plaintiff asserted claims of forward and reverse confusion, but neither succeeded. Although the court found the first of the plaintiff's marks arbitrary and the second suggestive, that did not prevent them from being commercially weak and therefore entitled to narrow scopes of protection.¹¹⁹⁸ Turning to the marks as they appeared in the marketplace, the court found "significant differences" in the parties' respective presentations, which included distinguishable bottle shapes, bottle closures, labels, and stylized lips.¹¹⁹⁹ Contrary to the rule usually applied in cases involving

¹¹⁹⁶ Citing the defendant's sales of 248,075 units and receipt of "over \$5 million in revenue," the court held "there was enough opportunity for confusion to make the absence of any evidence [of confusion] significant." *Id.*

¹¹⁹⁷ See *JL Beverage Co. v. Beam, Inc.*, 318 F. Supp. 3d 1188 (D. Nev. 2018).

¹¹⁹⁸ The court's determination of commercial weakness was driven by the plaintiff's failure to prove "extensive sales or advertising, especially for a national market"; indeed, the plaintiff had discontinued its promotional efforts three years before the introduction of the defendants' allegedly infringing mark in 2011. *Id.* at 1205. Worse still, "[the plaintiff] had only minimal sales in 2011 and did not produce credible evidence of any sales after 2011." *Id.* "Thus," the court found, "whatever marketplace recognition [the plaintiff's mark] possessed at the time of its relatively modest promotional efforts had likely waned to some degree by the time [the defendants' mark] launched." *Id.*

¹¹⁹⁹ *Id.* at 1207-08.

marks for alcoholic beverages,¹²⁰⁰ it also accepted the defendants' argument that "[c]onsumers give some thought to distilled spirits before purchasing them."¹²⁰¹ The court was similarly skeptical of the plaintiff's accusation of bad faith, finding that the "[the plaintiff] did not introduce evidence that [the defendants] acted intentionally to capitalize on or siphon off the goodwill of the [plaintiff's] brand."¹²⁰² The plaintiff successfully demonstrated the competitive proximity of the parties' goods¹²⁰³ and the parties' joint use of "the well-established, three-tier alcoholic beverage distribution system to sell their products,"¹²⁰⁴ but those showings ultimately were an insufficient basis for liability.

Although the plaintiff therefore lost on its claims, it nevertheless successfully defended itself against a counterclaim asserted by the defendants, who requested the court to order the cancellation of the registration covering the plaintiff's standalone lips design based on their prior use and registration of the following mark for "alcoholic beverages, namely, liqueurs and cordials":¹²⁰⁵



Consistent with the approach taken by a different court over the past year,¹²⁰⁶ as well as the Ninth Circuit historically,¹²⁰⁷ the defendants argued that the proper framework for evaluating their claim of likely confusion was the one that would have been applied by the Trademark Trial and Appeal Board, namely a comparison "of the marks in the abstract" and divorced from their presentation in the marketplace.¹²⁰⁸ Ultimately, however, the court undertook just

¹²⁰⁰ See, e.g., *Alfred Dunhill of London, Inc. v. Kasser Distillers Prods. Corp.*, 350 F. Supp. 1341, 1364 (E.D. Pa. 1972) ("[T]he average liquor consumer is not likely to exercise a high degree of care in his purchases . . .").

¹²⁰¹ *JL Beverage Co.*, 318 F. Supp. 3d at 1209.

¹²⁰² *Id.* at 1210.

¹²⁰³ *Id.* at 1206.

¹²⁰⁴ *Id.* at 1209.

¹²⁰⁵ *Id.* at 1193.

¹²⁰⁶ See *Combe Inc. v. Dr. August Wolff GmbH & Co. KG Arzneimittel*, 382 F. Supp. 3d 429, 444 (E.D. Va. 2019), *appeal docketed*, No. 19-1674 (4th Cir. June 24, 2019).

¹²⁰⁷ See *Wells Fargo & Co. v. Stagecoach Props., Inc.*, 685 F.2d 302, 306 & n.5 (9th Cir. 1982).

¹²⁰⁸ According to the court, "[t]he inquiry for determining 'likelihood of confusion for purposes of registration is the same standard as likelihood of confusion for purposes of infringement.'" *JL Beverage Co.*, 318 F. Supp. 3d at 1211 (quoting *B & B Hardware, Inc. v. Hargis Indus.*, 135 S. Ct. 1293, 1307 (2015)).

such an analysis, but resolved the issue in the plaintiffs', rather than the defendants' favor: "[T]here is no likelihood of confusion because the marks are so plainly dissimilar. . . . [T]he [defendants'] Mark's cartoonish quality differs markedly from the naturalistic depiction of lips in the [plaintiff's] Mark."¹²⁰⁹

(vii) Opinions Deferring Resolution of the Likelihood-of-Confusion Inquiry

As usual, defendants struck out when inviting courts to find as a matter of law at the pleadings stage of cases that plaintiffs' allegations of infringement failed to state claims.¹²¹⁰ One notable example of that outcome came in a case brought by Vanderbilt University against defendants that allegedly used its marks without authorization to create the impression that Vanderbilt was the source of, affiliated with, or sponsored the defendants' products.¹²¹¹ Vanderbilt's complaint included the following example of the defendants' promotional materials, which referenced a Vanderbilt professor emeritus:¹²¹²



¹²⁰⁹ *Id.* at 1211.

¹²¹⁰ *See, e.g.*, *Sullivan v. Bickler*, 360 F. Supp. 3d 778, 787-87 (N.D. Ill. 2019) (declining to dismiss allegation that defendant's use of SURVIVOR mark to promote his musical performances was likely to cause confusion over his possible membership in band operating under same mark); *Drone Racing League, Inc. v. DR1, LLC*, 129 U.S.P.Q.2d 1083, 1087-88 (S.D.N.Y. 2018) (declining to dismiss allegation of likely confusion between DRL and DR1 marks, both used for professional drone racing circuits); *BHR Recovery Cmty., Inc. v. Top Seek, LLC*, 355 F. Supp. 3d 416, 426 (E.D. Va. 2018) (declining to dismiss "unconventional" claim of infringement grounded in plaintiff's claim that defendant had "usurp[ed] its Google listing" by associating mark with competitive businesses); *GeigTech E. Bay LLC v. Lutron Elecs. Co.*, 352 F. Supp. 3d 265, 284-85 (S.D.N.Y. 2018) (declining to dismiss allegations of likely confusion in trade dress action between competitors in market for roller shade bracket jams); *Emanuel Mizrahi, DDS, P.C. v. Angela Andretta, DMD, P.C.*, 97 N.Y.S.3d 273, 276 (N.Y. App. Div. 2019) (affirming trial court's refusal to dismiss action by owner of FOREST HILLS ORTHODONTIC ASSOCIATES mark against users of FOREST HILLS ORTHODONTICS mark for directly competitive orthodontic services).

¹²¹¹ *See Vanderbilt Univ. v. Scholastic, Inc.*, 382 F. Supp. 3d 734 (M.D. Tenn. 2019).

¹²¹² *Id.* at 752.

Although acknowledging that “[f]actual statements about the past experience of an employee are not *per se* barred by the Lanham Act,”¹²¹³ the court credited Vanderbilt’s claim the defendants had gone too far, especially in light of the defendant’s use of the school’s stylized logo, which the court determined “served no informational purpose because the text already identified [the professor’s] association with Vanderbilt.”¹²¹⁴ “[O]n a robust reading of the Complaint and drawing all inferences in favor of the plaintiff,” the court concluded, “Vanderbilt has stated a Lanham Act trademark infringement claim.”¹²¹⁵

Another failed motion to dismiss was filed by defendants accused of infringing the trade dress of a ballet shoe.¹²¹⁶ The plaintiff’s complaint contained limited boilerplate recitations of likely confusion,¹²¹⁷ but it also set forth a photographic comparison between its shoe and that of the defendants.¹²¹⁸ Taken as a whole, the court held the plaintiff’s averments adequate to defeat the defendants’ motion. As it noted, “the likelihood of confusion is a factual issue dependent on the circumstances of each case and is ill-suited for resolution on a motion to dismiss.”¹²¹⁹ Moreover, “a plaintiff need not plead with specificity how the infringing trademark causes confusion.”¹²²⁰

Some refusals to resolve the likelihood-of-confusion inquiry as a matter of law came in appellate opinions. For example, in a rare application of its own law in the infringement context, the Federal Circuit vacated a finding of nonliability by the International Trade Commission and remanded the action for further proceedings below.¹²²¹ The case arose from the defendants’ alleged copying of a

¹²¹³ *Id.* at 751.

¹²¹⁴ *Id.* at 753.

¹²¹⁵ *Id.*

¹²¹⁶ *See* *Rothy’s, Inc. v. JKM Techs., LLC*, 360 F. Supp. 3d 373 (W.D. Va. 2018).

¹²¹⁷ As the court’s opinion quoted them, those recitations included the following claims:

On information and belief, the similarity between the two products is so striking that consumers seeing [Defendants’ shoe] have been and will continue to be confused into thinking that [it] was related to the [Plaintiff’s] product. As such, ordinary consumers are likely to be confused as to the source, sponsorship, affiliation or approval relating to [the defendants’] product vis-a-vis [Plaintiff] and it’s [sic] . . . product.

. . . .

The shape, design and look of Defendants’ . . . product is confusingly similar to [Plaintiff’s] product, and incorporates the distinctive features of [Plaintiff’s] product.

Id. at 386 (sixth alteration in original).

¹²¹⁸ *Id.*

¹²¹⁹ *Id.* (quoting *Stat Ltd. v. Beard Head, Inc.*, 60 F. Supp. 3d 634, 638 & n.1 (E.D. Va. 2014)).

¹²²⁰ *Id.*

¹²²¹ *See* *Converse, Inc. v. Int’l Trade Comm’n*, 909 F.3d 1110 (Fed. Cir. 2018).

federally registered midsole design incorporated into the plaintiff's shoes. Eschewing the multifactored test for likely confusion it has long used in the registration context, the court's analysis instead focused on a single consideration, namely, the degree of similarity between the parties' designs. As it held, "[i]n the context of trade-dress infringement, we also hold that accused products that are not substantially similar cannot infringe."¹²²² Without referencing any other likelihood-of-confusion factors, the court remanded the action with the instruction that "the ITC should reassess the accused products to determine whether they are substantially similar to the [plaintiff's] mark in the infringement analysis."¹²²³

In the process, the court went beyond the standard factors to address two arguments in favor of affirmance advanced by the defendants. First, the court rejected the defendants' claim that the labeling of their goods precluded confusion among consumers because "we have not held that such labeling is always legally sufficient to avoid likelihood of confusion but rather that those labels may be highly probative evidence."¹²²⁴ Second, it declined to treat the alleged lack of harm to the plaintiff as dispositive evidence of nonliability, holding that the case law proffered to support of that proposition failed to do so.¹²²⁵

At the trial court level, a number of motions for summary judgment—filed by plaintiffs and defendants alike—fell short. For example, a Massachusetts federal district court declined to find on a plaintiff's motion that confusion was likely between the plaintiff's SMARTLING mark and the defendant's EASYLING mark, both of which were used in connection with language translation services for mobile and Internet-based clients.¹²²⁶ The likelihood-of-confusion analysis began in promising fashion for the plaintiff in light of the court's finding that, "although the marks contain different words ('smart' vs. 'easy') and a different number of syllables, both marks are one-word, invented terms composed of an adjective preceding the 'ling' at the end of the mark";¹²²⁷ moreover, "[t]he manner in which these marks are displayed on each company's respective website also share similarities."¹²²⁸ Likewise, the plaintiff also successfully demonstrated the competitive proximity of the parties' products,¹²²⁹ the use of "the same trade

¹²²² *Id.* at 1124.

¹²²³ *Id.*

¹²²⁴ *Id.*

¹²²⁵ *Id.*

¹²²⁶ See *Smartling, Inc. v. Skawa Innovation Ltd.*, 358 F. Supp. 3d 124 (D. Mass. 2019).

¹²²⁷ *Id.* at 139.

¹²²⁸ *Id.*

¹²²⁹ *Id.* at 140.

channels and forms of advertising,”¹²³⁰ a shared customer base,¹²³¹ possible intentional copying of the plaintiff’s mark by the defendant,¹²³² and the possible suggestiveness of the plaintiff’s mark.¹²³³ Nevertheless, the coexistence of the parties’ marks for eleven years without actual confusion weighed “strongly” in the defendant’s favor,¹²³⁴ and that consideration itself created a sufficient conflict in the summary judgment record to preclude a grant of the plaintiff’s motion.¹²³⁵

A different motion for summary judgment of liability failed in a case brought by entertainer Beyoncé and one of her companies, the latter of which owned a federal registration of her name for various items of clothing, against defendants selling their own clothing under the FEYONCÉ mark.¹²³⁶ That some of the likelihood-of-confusion factors of record favored the plaintiffs’ position was beyond material dispute, including the strength of her mark,¹²³⁷ the competitive nature of the parties’ goods, which were sold in overlapping channels of distribution,¹²³⁸ and the lack of sophistication among consumers of the goods in question.¹²³⁹ Rather improbably, however, the court agreed with the defendants that “there is a triable issue of fact as to whether the similarity between

¹²³⁰ *Id.*

¹²³¹ *Id.* at 140-41.

¹²³² That possibility was raised by the creation of an account with the plaintiff by the defendant’s CEO one day before the defendant’s registration of domain name based on the defendant’s allegedly infringing mark. *Id.* at 143. Beyond that, “[v]iewed in the light most favorable to the non-moving party, the original [defendant’s] website also shared at least a similar color scheme and layout, identical terms and conditions language, and a promotional video that used similar elements as a promotional video hosted on [the plaintiff’s] website.” *Id.* “[A]lthough the evidence of intentional copying is not particularly robust,” the court found, “this factor weighs at least slightly in favor of [the plaintiff] at this stage of the case.” *Id.*

¹²³³ *Id.* at 143-44.

¹²³⁴ *Id.* at 141.

¹²³⁵ *Id.* at 144 (“Even given that the other factors favor [the plaintiff], the absence of actual confusion weighs strongly against the likelihood of confusion, which is critical to the claims asserted.”).

The court then reached the same conclusion with respect to the plaintiff’s claim that the defendant had created a likelihood of confusion by copying the allegedly nonfunctional and distinctive appearance of the plaintiff’s website. That holding was driven in substantial part by the court’s finding that a reasonable jury might find the parties’ verbal marks confusingly similar. *Id.* at 150 (“[T]he Easyling mark viewed in isolation could have been confused with the Smartling mark, and a jury could reasonably conclude that the other features of the site that [the defendant’s] copied made that confusion more likely.”).

¹²³⁶ See *Knowles-Carter v. Feyonce, Inc.*, 347 F. Supp. 3d 217 (S.D.N.Y. 2018).

¹²³⁷ *Id.* at 227.

¹²³⁸ *Id.*

¹²³⁹ *Id.*

the marks is likely to cause confusion,”¹²⁴⁰ especially because “[b]y replacing the ‘B’ with an ‘F,’ Defendants have created a mark that sounds like ‘fiancé,’ i.e., a person who is engaged to be married.”¹²⁴¹ Even more improbably, it then concluded that “[b]ecause the Court is unconvinced as to similarity, it is also unprepared to conclude as a matter of law that Defendants acted in bad faith,”¹²⁴² despite undisputed record evidence that the defendants’ clothing featured “certain phrases from Beyoncé’s well known songs.”¹²⁴³ Ultimately, it concluded that “the core of the inquiry is whether ordinary purchasers would have difficulty distinguishing the products or ascertaining whether the junior product is affiliated with or sponsored by the senior mark’s owner, and the Court cannot conclude as a matter of law that this type of confusion is likely.”¹²⁴⁴

In a case presenting an unsuccessful defense motion for summary judgment, the parties provided cleaning services for crawl spaces and attics.¹²⁴⁵ The defendant attempted to frame the issue as a potential conflict between the plaintiff’s registered CLEAN CRAWLS mark and its own CRAWL SPACE CLEANING PROS mark, but, based on the defendant’s actual usage, the court considered as well the possibility of liability arising from the defendant’s use of CRAWL PROS as well. Addressing the similarity between the parties’ marks, it concluded that:

While the Court sees little visual similarity between the marks[,] particularly when incorporating the logos and colors, a reasonable juror could find likely auditory similarity given the repetition of words with similar meaning beginning with a hard ‘c’ sound, particularly in a word-of-mouth context where a trade name may not be perfectly articulated. Thus, putting more emphasis on similarities, this factor also weighs in favor of [the plaintiff].¹²⁴⁶

The defendant’s position did not improve under the court’s analysis of the other likelihood-of-confusion factors, which took into account the undisputedly competitive nature of the parties’ services,¹²⁴⁷ as well as credited the plaintiff’s showings of bad faith by the defendant (the parties previously had been affiliated),¹²⁴⁸ actual

¹²⁴⁰ *Id.* at 224-25.

¹²⁴¹ *Id.* at 225.

¹²⁴² *Id.* at 226.

¹²⁴³ *Id.* at 222.

¹²⁴⁴ *Id.* at 227.

¹²⁴⁵ *See* *Clean Crawl, Inc. v. Crawl Space Cleaning Pros, Inc.*, 364 F. Supp. 3d 1194 (W.D. Wash. 2019).

¹²⁴⁶ *Id.* at 1208 (citation omitted).

¹²⁴⁷ *Id.* at 1208-09.

¹²⁴⁸ *Id.* at 1209.

confusion,¹²⁴⁹ shared promotional media,¹²⁵⁰ and a diminished degree of care exercised by consumers needing the parties' services on an emergency basis.¹²⁵¹ In the final analysis, "[t]he Court finds [the plaintiff's claim of initial-interest confusion] plausible and supported by the instances of consumer confusion."¹²⁵²

Courts also denied cross-motions for summary judgment on the issue of likely confusion. One did so in a long-running battle by the owners of marks comprising MARILYN MONROE, MARILYN, and a stylized pair of lips for various goods, including clothing, on the one hand, and a group of defendants accused of affixing imitations of those marks to goods including T-shirts, on the other.¹²⁵³ In denying the counterclaim plaintiffs' motion, the court found a factual dispute over whether the counterclaim defendants' use of the MARILYN MONROE and MARILYN marks communicated an association with the counterclaim plaintiffs or, alternatively, whether consumers were more likely to view it as merely identifying the individual (Monroe) whose image appeared on the counterclaim defendants' shirts. Likewise, in denying the counterclaim defendants' motion, it found their arguments undermined by what appeared to be their copying of the counterclaim plaintiffs' presentation of the marks.¹²⁵⁴ The matter therefore proceeded toward trial.

(2) The First-Sale Doctrine and Likelihood of Confusion Arising from the Diversion or Alteration of Genuine Goods

The multifaceted likelihood-of-confusion test for liability is appropriate in cases in which a defendant has affixed an allegedly infringing mark to its own goods, but the utility of that test may be limited if the challenged use in question consists of the defendant's resale of genuine goods originally produced by the plaintiff: Under

¹²⁴⁹ The plaintiff's showing on that issue rested on the defendant's own discovery responses:

In responses to [the plaintiff's] interrogatories, [the defendant] provided eight specific instances of customer confusion, including six conversations where the customers had had more than cursory interaction, such as an estimate or actual work done, with CCI, and had mistakenly contacted [the defendant] to follow up. These instances appear to be strong evidence of exactly the kind of consumer difficulty in "distinguish[ing] among competing producers" that trademark laws seek to address.

Id. (citation omitted) (quoting *Park 'N Fly, Inc. v. Dollar Park & Fly, Inc.*, 469 U.S. 189, 198 (1985)).

¹²⁵⁰ *Id.*

¹²⁵¹ *Id.* at 1210.

¹²⁵² *Id.*

¹²⁵³ See *A.V.E.L.A., Inc. v. Estate of Marilyn Monroe, LLC*, 364 F. Supp. 3d 291 (S.D.N.Y. 2019).

¹²⁵⁴ *Id.* at 314-15.

those circumstances, the first-sale, or exhaustion, doctrine ordinarily will render that resale nonactionable. Nevertheless, if the resold goods materially differ from their authorized counterparts, they will not qualify as genuine for purposes of that doctrine.

The D.C. Circuit applied the second of these two rules in a somewhat unusual context.¹²⁵⁵ The defendant appealing an adverse summary judgment order to that court was a non-profit organization with a goal of reproducing and making freely accessible numerous technical standards originally produced by the plaintiffs but given the force of law by state and federal agencies and legislatures. The summary judgment record established that the defendant's copies of the plaintiffs' standards were not exact reproductions. Instead, the defendant generated them through a combination of scanning and retyping, which led to errors and differences between the copies and the plaintiffs' original standards. Those variances exposed the defendant to the plaintiffs' infringement-based challenges. As the court explained, the defendant's conduct implicated "trademark law's concern for 'discourag[ing] those who hope to sell inferior products by capitalizing on a consumer's inability quickly to evaluate the quality of an item offered for sale.'"¹²⁵⁶

In an application of the same general rule but in a more conventional context, a Tennessee federal district court held that "the [first-sale] doctrine provides no defense when the reseller sells trademarked goods that are materially different from those sold by the trademark owner."¹²⁵⁷ The occasion of that holding was a motion for a default judgment by a pair of telecommunications companies against a group of defendants alleged to have diverted, through a variety of fraudulent means, genuine telephones intended for the plaintiffs' customers before "unlocking" the phones and reselling them; the defendants' conduct resulted in the phones having bad electronic serial numbers that precluded end users from enjoying all the benefits otherwise associated with the phones. In the absence of opposition by the defendants, the court found that "[a]lthough the inconsistency between the phones stems from [the plaintiffs'] practices rather than some technological limitation, the sale of the phones constitutes infringement."¹²⁵⁸ Of equal importance, it also accepted the plaintiffs' averment that phones sold by the defendants lacked the same manufacturers' warranty protection as their authorized counterparts, the significance of which was that prior

¹²⁵⁵ See *Am. Soc'y for Testing & Materials v. Public.Resource.Org, Inc.*, 896 F.3d 437 (D.C. Cir. 2018).

¹²⁵⁶ *Id.* at 455 (alteration in original) (quoting *Qualitex Co. v. Jacobson Prods. Co.*, 514 U.S. 159, 163-64 (1995)).

¹²⁵⁷ *Sprint Sols., Inc. v. Lafayette*, 127 U.S.P.Q.2d 1256, 1267 (W.D. Tenn. 2018).

¹²⁵⁸ *Id.* at 1267.

cases had held that “reselling products with inferior warranties constitutes a material difference.”¹²⁵⁹ Because “[t]he material difference exception to the first-sale doctrine applies,” the plaintiffs’ averments established the defaulting defendants’ liability.¹²⁶⁰

A California federal district court also rejected the applicability of the first-sale doctrine as a matter of law in an action in which the goods sold by the defendants—end caps for automotive wheels—were not, in fact, genuine, despite bearing the plaintiff’s marks.¹²⁶¹ The court’s resolution of the issue was simple and to the point:

The Court has examined the two products produced at oral argument and determines the end cap from Defendants’ wheels is clearly different from Plaintiff’s end cap. The back of Plaintiff’s end cap contains a part number. The back of Defendants’ end cap contains a sticker with what appears to be Chinese characters printed on it.¹²⁶²

Taken together with the defendants’ inability to substantiate their claim that they had purchased their goods from authorized sources, these differences rendered the first-sale doctrine wholly inapposite; rather than having been affixed under the plaintiff’s authority to genuine goods, the disputed marks were counterfeit.¹²⁶³

(3) Survey Evidence of Actual or Likely Confusion

Perhaps the greatest return on the investment necessary for a survey at the liability stage of an infringement action documented in a reported opinion over the past year took place in a district court appeal from a Trademark Trial and Appeal Board order dismissing an opposition.¹²⁶⁴ In taking that action, the Board held confusion unlikely between the plaintiff’s VAGISIL mark in connection with a vaginal moisturizer/gel, creams, deodorant powder, wipes, washes, and other vaginal care products, on the one hand, and the defendant’s VAGISAN mark for vaginal moisturizers, vaginal anti-fungal preparations, and vaginal washes. On appeal, the plaintiff successfully bolstered its case with the results of an *Eveready*-style¹²⁶⁵ “monadic” survey, which documented a net 19 percent confusion rate among respondents.

The court offered the following summary of the methodology used by the plaintiff’s survey expert to yield those results:

¹²⁵⁹ *Id.* at 1268.

¹²⁶⁰ *Id.*

¹²⁶¹ *See* Daimler AG v. A-Z Wheels LLC, 334 F. Supp. 3d 1087 (S.D. Cal. 2018).

¹²⁶² *Id.* at 1100.

¹²⁶³ *Id.*

¹²⁶⁴ *See* Combe Inc. v. Dr. August Wolff GmbH & Co. KG Arzneimittel, 382 F. Supp. 3d 429 (E.D. Va. 2019), *appeal docketed*, No. 19-1674 (4th Cir. June 24, 2019).

¹²⁶⁵ *See* Union Carbide Corp. v. Ever-Ready, Inc., 531 F.2d 366 (7th Cir. 1976).

The Confusion Survey was . . . administered to two hundred respondents in a control group, who were shown the fictitious name VAGIPUR instead of VAGISAN. VAGIPUR was shown to the control group respondents in a plain, block letter format, without any trade dress, stylization, special font, colors, company name, packaging, or any other distinctive elements and with the description “vaginal moisturizers, vaginal washes and vaginal anti-fungal products.”

When presented with the VAGISAN mark, 37% of the respondents in the test group named VAGISIL in response to the confusion questions. In the control group, 18% of the respondents named VAGISIL after they were shown the VAGIPUR mark and were asked the confusion questions. Accordingly, the Confusion Survey reported a net confusion rate of 19% between VAGISAN and VAGISIL; that is, it reflected that 19% of respondents confused VAGISAN with VAGISIL specifically because of the marks’ similarity and not because of other factors.¹²⁶⁶

Although the defendant retained its own survey expert to criticize the plaintiff’s survey methodology, the court rejected those criticisms seriatim. In particular, it found: (1) the survey need not have considered how the parties’ marks appeared in the marketplace because the only issue at stake was the registrability of the defendant’s mark;¹²⁶⁷ (2) “[a]lthough it is conceivable that a different, more similar control could have been selected, the control used by [the plaintiff’s expert] was adequate to measure survey ‘noise’”;¹²⁶⁸ and (3) the plaintiff’s expert had not improperly coded certain responses as documenting confusion among respondents.¹²⁶⁹

As that outcome suggests, courts entertaining challenges to survey evidence typically hold that flaws in the methodologies of the surveys producing that evidence go to the weight of the evidence and not its admissibility. A New York federal district court therefore declined to exclude the results of an *Eveready* survey commissioned by counterclaim plaintiffs in a case in which they asserted various rights associated with deceased celebrity Marilyn Monroe.¹²⁷⁰ It did so in part because the counterclaim defendants’ challenge to the

¹²⁶⁶ *Combe Inc.*, 382 F. Supp. 3d at 439-40 (paragraph numbering omitted).

¹²⁶⁷ On this issue, the court held that “the TTAB has repeatedly and correctly concluded [that] the only scientifically sound format for a survey designed to test the likelihood confusion in a registrability proceeding is to display the applicant’s mark as it appears in the registration application.” *Id.* at 463.

¹²⁶⁸ *Id.* at 464.

¹²⁶⁹ *Id.* at 465.

¹²⁷⁰ See *A.V.E.L.A., Inc. v. Estate of Marilyn Monroe, LLC*, 364 F. Supp. 3d 291 (S.D.N.Y. 2019).

results targeted neither the credentials of the counterclaim plaintiffs' expert nor his methodology. Instead, the counterclaim defendants asserted that the survey failed to instruct respondents not to guess—only to have the court note that it “contained the explicit instruction, ‘Please do not guess.’”¹²⁷¹ The court next rejected the counterclaim defendants' objection that “respondents did not identify [the lead counterclaim plaintiff] by name, but rather made statements suggesting Ms. Monroe or the people around her endorsed [the counterclaim defendants' goods]”¹²⁷² because a survey need not “screen explicitly for recognition of the entity claiming rights to be probative.”¹²⁷³ It then found the absence of a particular retailer's hang tag from a stimulus rendered the survey fatally flawed, citing testimony by the counterclaim plaintiffs' expert that he had purchased the stimulus from a different source.¹²⁷⁴ Finally, the court noted, “[t]he parties also clash on the appropriate control group, the sample size, and the mechanism for categorizing responses, but the Court does not believe it is necessary to examine each of these disputes in detail when the Second Circuit has admonished courts that these disputes go to weight rather than admissibility.”¹²⁷⁵

The general rule in favor of the admissibility of survey results extended to those produced by *Squirt*-style¹²⁷⁶ sequential array surveys. That phenomenon was perhaps most pronounced in a case before a New York federal district court in which the plaintiff, a purveyor of socks that often featured licensed characters from comic books, sought to enforce the rights to a federally registered mark against the manufacturers of socks sold primarily to athletic teams.¹²⁷⁷ To support its case, the plaintiff commissioned a *Squirt* survey, which, the plaintiff's expert reported, yielded a net confusion rate of 12.0 percent among respondents generally and a net confusion rate of 21.6 percent among the athletic coaches who were the defendant's primary customers.¹²⁷⁸ Although the latter figure was on the low side, the court might well have accepted it as probative evidence of liability under authority from the same district,¹²⁷⁹ but that was not to be in light of problems with the survey's methodology.

¹²⁷¹ *Id.* at 326.

¹²⁷² *Id.*

¹²⁷³ *Id.*

¹²⁷⁴ *Id.*

¹²⁷⁵ *Id.*

¹²⁷⁶ See generally *SquirtCo. v. Seven-Up Co.*, 628 F.2d 1086 (8th Cir. 1980).

¹²⁷⁷ See *Hypnotic Hats, Ltd. v. Wintermantel Enters.*, 335 F. Supp. 3d 566 (S.D.N.Y. 2018).

¹²⁷⁸ *Id.* at 590.

¹²⁷⁹ See, e.g., *Borghese Trademarks Inc. v. Borghese*, No. 10 Civ. 5552 (JPO)(AJP), 2013 WL 143807, at *11 (S.D.N.Y. Jan. 14, 2013) (15 percent net confusion rate); *EnergyBrands*,

Although denying a defense motion to exclude the survey's results, the court accorded them only "limited weight."¹²⁸⁰ Chief among the problems it identified was the format itself: Because the parties' goods were not sold in direct proximity to each other, the court held that use of the *Squirt* format was "inappropriate."¹²⁸¹ Moving beyond that issue, it additionally faulted the plaintiff's expert for using leading questions such as "Do you think these socks . . . and any of the socks you saw in the first section of the survey are made or put out by the same company?"¹²⁸² The court found the results "less credible" for the additional reason that the expert had miscoded "numerous answers related to the similarity of the socks, not of their source," as well as other "incomprehensible or unresponsive" answers, as evidence of confusion.¹²⁸³ Moreover, the court agreed with the defendants' argument that the "distractor" names to which the survey exposed respondents were "markedly different from [the plaintiff's], which could lead to artificially high rates of association."¹²⁸⁴ Finally, it criticized the survey because "the test group (exposed to [the plaintiff's mark]) and the control group (exposed to the fictional [control brand]) were not equally exposed to the respective marks"¹²⁸⁵ and because of the high rate of "noise"—38 percent—among respondents in the control group.¹²⁸⁶ With considerable understatement, the court noted that "[t]he survey contains numerous methodological errors,"¹²⁸⁷ but still deemed it not so devoid of probative value to warrant the exclusion of its results from evidence altogether.

The same result held with respect to another *Squirt*-style survey commissioned by a plaintiff seeking to protect as trade dress the appearance of the bags in which it sold its lollipops, shown below on the left, against the allegedly infringing packaging shown on the right:¹²⁸⁸

Inc. v. Beverage Marketing USA, Inc., No. 02 Civ. 3227, 2002 WL 826814, at *2 (S.D.N.Y. May 1, 2002) (17 percent net confusion rate); *RJR Foods, Inc. v. White Rock Corp.*, 201 U.S.P.Q. 578, 581 (S.D.N.Y. 1978) (15–20 percent net confusion rate), *aff'd*, 603 F.2d 1058 (2d Cir. 1979).

¹²⁸⁰ *Hypnotic Hats*, 335 F. Supp. 3d at 590.

¹²⁸¹ *Id.* at 597.

¹²⁸² *Id.* at 598 (alteration in original).

¹²⁸³ *Id.*

¹²⁸⁴ *Id.* at 598, 599.

¹²⁸⁵ *Id.*

¹²⁸⁶ *Id.*

¹²⁸⁷ *Id.*

¹²⁸⁸ *See Spangler Candy Co. v. Tootsie Roll Indus.*, 372 F. Supp. 3d 588, 594 (N.D. Ohio), *appeal dismissed*, No. 19-3227, 2019 WL 2564576 (6th Cir. May 10, 2019).



After viewing the plaintiff's packaging, respondents were then exposed to a test cell comprising the defendant's packaging along with the following controls:



The defendant leveled two criticisms at the controls, the first of which was that the plaintiff's survey expert should have used a "control group," rather than multiple "control products" in a sample group.¹²⁸⁹ Although the court rejected that criticism because "while the use of proper controls is necessary, a control *group* is not mandated,"¹²⁹⁰ it took the defendant's second criticism more seriously, which was that the controls did not resemble either party's packaging; with respect to that claimed deficiency, the court found that "the controls here are certainly flawed . . ."¹²⁹¹

Neither that deficiency nor another one identified by the defendant resulted in the exclusion of the survey results, however. The second significant flaw in the survey's methodology was its reliance on closed-ended questions, which the defendant argued did not evaluate the likelihood that factors other than similarities in the

¹²⁸⁹ *Id.* at 597.

¹²⁹⁰ *Id.*

¹²⁹¹ *Id.* at 598.

parties' respective packages influenced respondents' answers to the survey's questions. Because the survey offered a "Don't Know/No Opinion" option for each closed-ended question, the court found the questions were neither unduly suggestive nor guess-inducing. Nevertheless, because the survey collected no information as to the respondents' rationale, something an open-ended question could have assessed, "whether respondents were influenced by factors other than trade-dress similarity remains unknown."¹²⁹² Together with the flawed controls, this consideration precluded the survey results from receiving anything more than "little weight," with the result that "[the plaintiff] is unable to show any actual confusion."¹²⁹³

Finally, one court proved unconvinced by the results of a survey commissioned by defendants accused of infringing the trade dress of protein pancake mix packaging.¹²⁹⁴ The defendants' expert opined that a net 7 percent of respondents participating in the survey—the methodology of which went undescribed—believed the plaintiff was the source of the defendants' goods and that 5.7 percent of respondents believed the parties were affiliated in some manner. The court, however, found more convincing the "raw data" emerging from the survey, by which it apparently meant the overall positive results without accounting for noise. It read those data to show that "28% of respondents believed that Kodiak was the source of the protein mix and 42.4% of respondents believed there was some relation between the two pancake mixes."¹²⁹⁵ Worse still, from the court's perspective, numerous comments by respondents expressly questioned the lawfulness of the defendants' trade dress.¹²⁹⁶ Rather than showing confusion was unlikely, the survey results therefore weighed in favor of liability.¹²⁹⁷

¹²⁹² *Id.* at 599.

¹²⁹³ *Id.* at 605.

¹²⁹⁴ *See Kodiak Cakes LLC v. Cont'l Mills, Inc.*, 358 F. Supp. 3d 1219 (D. Utah 2019).

¹²⁹⁵ *Id.* at 1233.

¹²⁹⁶ As the court summarized those responses:

[T]hose statements [by respondents] include some of the following comments about the similarity of the packaging: "They basically took the entire design and could get sued;" "They look exactly the same just with different pictures and words;" "The product seems identical;" "They look almost exactly alike;" "Wouldn't it be copyright infringement or something[?] I don't think it's legal to do that."

Id.

¹²⁹⁷ *Id.*

***(C) Liability for the Trafficking in Goods and Services
Associated with Counterfeit Imitations of Marks***

(1) Civil Liability

To be an actionable counterfeit under federal law, a challenged mark must be a “spurious” copy of one covered by a federal register, which means it must be “identical [to], or substantially indistinguishable from, a registered mark.”¹²⁹⁸ That definition is a restrictive one,¹²⁹⁹ and the Eighth Circuit gave it full effect in overturning a jury finding that a group of defendants had trafficked in shot glasses bearing counterfeit imitations of the plaintiff’s mark.¹³⁰⁰ A comparison between the drawing in the plaintiff’s registration and the defendant’s use shows why the court took that step:¹³⁰¹



As it explained, “the differences between the [defendants’] glass’s design and the [plaintiff’s registered] mark are so obvious that the jury did not have any basis in the record for its finding of a counterfeit.”¹³⁰²

Nevertheless, some civil causes of action for counterfeiting succeeded,¹³⁰³ and, indeed, some reached findings of liability as a

¹²⁹⁸ 15 U.S.C. § 1127 (2018).

¹²⁹⁹ A plaintiff unable to prove a likelihood of confusion in support of a conventional claim of infringement is obviously in a poor position to pursue a cause of action for counterfeiting. *See, e.g.,* Springboards to Educ., Inc. v. Hous. Indep. Sch. Dist., 912 F.3d 805, 818 (5th Cir. 2019) (affirming dismissal of plaintiff’s claim of counterfeiting as a matter of law in light of failure to establish factual dispute as to defendant’s nonliability for infringement), *as revised* (Jan. 29, 2019), *and as revised* (Feb. 14, 2019).

¹³⁰⁰ *See* Sturgis Motorcycle Rally, Inc. v. Rushmore Photo & Gifts, Inc., 908 F.3d 313 (8th Cir. 2018), *on remand*, 129 U.S.P.Q.2d 1392 (D.S.D. 2019).

¹³⁰¹ *Id.* at 338.

¹³⁰² *Id.* at 340.

¹³⁰³ *See, e.g.,* John Wiley & Sons, Inc. v. Book Dog Books, LLC, 327 F. Supp. 3d 606, 622-23 (S.D.N.Y. 2018) (declining to disturb jury finding of counterfeit marks affixed to books).

matter of law.¹³⁰⁴ In perhaps the most notable one to reach such an outcome, the plaintiffs manufactured HARLEY-DAVIDSON-branded motorcycles, and their action sought to vindicate their rights to the HARLEY-DAVIDSON, HARLEY, H-D, FAT BOY, HARLEY DAVIDSON 1, SPORTSTER verbal marks as well as a stylized skull, all of which were registered for “motorcycles, motorcycle parts and accessories, and various other products and services, including apparel, mugs, and posters.”¹³⁰⁵ For its part, the lead defendant marketed, printed, and sold apparel, including T-shirts, sweatshirts, hoodies, leggings, and other products such as mugs, on its website. The defendant itself created no designs, graphics, or images for use on products; rather, it provided an online platform on which third parties could: (1) upload designs or artwork for application to the goods sold on the site; and (2) open accounts as “sellers” of those and other goods.¹³⁰⁶

Although the lead defendant styled itself as an intermediary, that putative status did not immunize it from liability for sales of goods bearing counterfeit imitations of the plaintiff’s marks even after receiving notice of the plaintiff’s objections to those sales and, indeed, even after the court preliminarily enjoined it from doing so. Caught dead to rights—the court found that “[w]hile technically different in some respects, [the lead defendant’s] uses of the marks are substantially indistinguishable from the registered marks in terms of their appearance in context”¹³⁰⁷—the lead defendant feebly invoked the putative difficulty in monitoring its online marketplace before arguing that the low quality of its goods necessarily tipped off consumers to the goods’ unauthorized status. The court was unconvinced, holding instead that “a counterfeiter cannot escape liability simply by reproducing protected marks on poor products. This would create perverse incentives for infringers and leave [the

¹³⁰⁴ See, e.g., *Chanel, Inc. v. Replicachanelbag*, 362 F. Supp. 3d 1256, 1261 (S.D. Fla. 2019) (granting unopposed motion for default judgment after concluding from complaint that “[a]lthough each Defendant may not copy and infringe each [of Plaintiff’s marks] for each category of goods protected, Plaintiff has submitted sufficient evidence showing each Defendant has infringed, at least, one or more of the Plaintiff’s marks”); *ICCS USA Corp. v. United States*, 357 F. Supp. 3d 1314, 1325 (Ct. Int’l Trade 2018) (rejecting as a matter of law would-be importer’s argument that appearance of unauthorized imitation of registered mark on goods was “purely cosmetic and “only for marketing purposes”); *Spin Master Ltd. v. Alan Yuan’s Store*, 325 F. Supp. 3d 413, 422 (S.D.N.Y. 2018) (granting unopposed motion for summary judgment and finding “[i]t . . . undisputed that the products sold by the defendants are counterfeit products and are thus inherently confusing to consumers”).

¹³⁰⁵ *H-D U.S.A., LLC v. SunFrog, LLC*, 311 F. Supp. 3d 1000, 1101 (E.D. Wis.), *appeal dismissed*, No. 18-2073, 2018 WL 6039900 (7th Cir. July 19, 2018).

¹³⁰⁶ *Id.* at 1013.

¹³⁰⁷ *Id.* at 1028.

plaintiff] without the power to police the use of its marks in many instances.”¹³⁰⁸

A separate opinion imposing liability as a matter of law involved the unauthorized sale of goods bearing the plaintiff’s registered certification mark.¹³⁰⁹ The plaintiff had repeatedly advised the defendants they could not use its mark until the plaintiff had inspected the goods to which the mark had been applied. The defendants argued they believed such an inspection took place when a representative of the plaintiff visited their offices, but that argument rested only on self-serving declaration testimony and what the court determined were “unreasonable inferences” drawn from an e-mail following the visit.¹³¹⁰ The plaintiff’s motion for summary judgment therefore proved meritorious.

The requirements for summary judgment of liability similarly proved no obstacle in another opinion.¹³¹¹ That came in a case brought by the owner of the PEPPA PIG property against defendants caught selling cookie cutters in the shape of the head of the animated stylized pig of the same name. Not only did the defendants’ cookie cutters incorporate the pig’s (federally registered) design, the defendants also marketed those goods using the plaintiff’s word mark. With the defendants contesting the plaintiff’s complaint only through conclusory denials of liability, the court predictably granted the plaintiff’s motion for summary judgment.¹³¹²

Finally, in another case crying out for the same resolution, automaker Daimler AG successfully prosecuted a civil counterfeiting action against a group of defendants caught selling wheels bearing spurious imitations of Daimler’s registered mark.¹³¹³ The defendants claimed the goods they sold were genuine, but the court accepted Daimler’s showing of significant differences between its goods and those of the defendants. From there, it was all over for the defendants. In an apparent concession that their goods were *not* genuine, the defendants also argued they had described the goods as “replicas,” but the court found from the summary judgment record that “this is not always the case.”¹³¹⁴ Plus, “[e]ven if a consumer were to read the entire product description of the wheel on, for example, eBay, that consumer would most likely not be alerted to the fact that the wheel is only a replica.”¹³¹⁵

¹³⁰⁸ *Id.*

¹³⁰⁹ *See* UL LLC v. Am. Energy Prod., LLC, 358 F. Supp. 3d 753 (N.D. Ill. 2019).

¹³¹⁰ *Id.* at 759.

¹³¹¹ *See* Entm’t One UK Ltd. v. 2012Shiliang, 384 F. Supp. 3d 941 (N.D. Ill. 2019).

¹³¹² *Id.* at 950.

¹³¹³ *See* Daimler AG v. A-Z Wheels LLC, 334 F. Supp. 3d 1087 (S.D. Cal. 2018).

¹³¹⁴ *Id.* at 1097.

¹³¹⁵ *Id.*

(2) Criminal Liability

In the only readily apparent reported opinion to tackle the issue of criminal liability for trafficking in goods bearing counterfeit marks, a panel of the Appellate Court of Illinois declined to overturn a conviction under the law of that state.¹³¹⁶ Reviewing the relevant statute,¹³¹⁷ the court held that:

[T]he elements of the offense that the State had to prove beyond a reasonable doubt were that defendant (1) knowingly kept or had in his possession, (2) with intent that the same shall be sold or disposed of, (3) any goods or merchandise to which a counterfeit mark was attached or affixed, and (4) that he was not the rightful owner of such trademark depicted.¹³¹⁸

The defendant contested only the third of these requirements, arguing that it necessarily contemplated an intent to deceive and that it had gone unsatisfied at trial because he had advised the officer who arrested him that his goods were “fake.” That argument failed to convince the court, which affirmed the conviction with the observation that “the purpose of the Act is not only to penalize those individuals selling counterfeit items under the guise that the items are authentic, but also to penalize those who disclaim to the consumer, as was done in this case, that the item is “fake.”¹³¹⁹ “In both scenarios,” it held, “the offender is infringing on trademarks by trafficking [in] counterfeit items bearing registered trademarks, and misappropriating the investment of the trademark holder.”¹³²⁰ It then rejected the defendant’s fallback argument that the relevant statute was unconstitutional because it punished wholly innocent conduct; on the contrary, the court pointed out, the prerequisites for a conviction under the statute included “knowing” conduct by a defendant.¹³²¹

(D) Dilution

(1) Mark Fame and Distinctiveness

To qualify for protection against dilution under federal law, a mark must be famous as of the defendant’s date of first use.¹³²² This means it must have been “widely recognized by the general consuming public of the United States as a designation of source of

¹³¹⁶ See *People v. Gueye*, 121 N.E.3d 1019 (Ill. Ct. App. 2018), *reh’g denied* (July 24, 2018).

¹³¹⁷ 65 Ill. Comp. Stat. § 1040/2 (West 2014).

¹³¹⁸ *Gueye*, 121 N.E.3d at 1025.

¹³¹⁹ *Id.* at 1027.

¹³²⁰ *Id.*

¹³²¹ *Id.* at 1028.

¹³²² 15 U.S.C. § 1125(c)(1) (2018).

the goods or services of the mark's owner,"¹³²³ a determination Congress has indicated should turn on the following nonexclusive factors:

- (i) The duration, extent, and geographic reach of advertising and publicity of the mark, whether advertised or publicized by the owner or third parties.
- (ii) The amount, volume, and geographic extent of sales of goods or services offered under the mark.
- (iii) The extent of actual recognition of the mark.
- (iv) Whether the mark was registered under the Act of March 3, 1881, or the Act of February 20, 1905, or on the principal register.¹³²⁴

In contrast, the dilution statutes of some states, such as that of New York,¹³²⁵ require a threshold showing of mark distinctiveness.¹³²⁶ As always, these prerequisites generated reported opinions applying them.

(a) Opinions Finding Mark Fame and Distinctiveness

Some plaintiffs' marks were sufficiently famous that courts found them eligible for protection under Section 43(c) as a matter of law.¹³²⁷ For example, when motorcycle manufacturer Harley-Davidson and its intellectual property holding company encountered an online marketplace on which goods bearing unauthorized copies of their marks were sold, the resulting complaint asserted claims for likely dilution under Section 43(c) as well as for infringement.¹³²⁸ When those plaintiffs sought summary judgment following the close of discovery, their moving papers included a request that the court find a number of marks famous. Those included HARLEY-DAVIDSON, HARLEY, H-D, HD, FAT BOY, and SPORTSTER marks, as well as the following composite and design marks, all of which were used in connection with

¹³²³ *Id.* § 1125(c)(2)(A).

¹³²⁴ *Id.* § 1125(c)(2)(A)(i)-(iv).

¹³²⁵ N.Y. Gen. Bus. Law § 360-1 (McKinney 2012).

¹³²⁶ *See Knowles-Carter v. Feyonce, Inc.*, 347 F. Supp. 3d 217, 229 (S.D.N.Y. 2018) (noting that plaintiffs proceeding under New York dilution statute need only demonstrate ownership of a "truly distinctive" mark or one with secondary meaning).

¹³²⁷ *See, e.g., City of N.Y. v. Tavern on the Green Int'l LLC*, 351 F. Supp. 3d 680, 695 (S.D.N.Y. 2018) (finding TAVERN ON THE GREEN mark famous as a matter of law for restaurant and bar services in light of defendant's failure to contest issue); *Knowles-Carter*, 347 F. Supp. 3d at 221 (finding BEYONCÉ mark "exceedingly famous" as a matter of law without discussion of record evidence or testimony supporting that finding).

¹³²⁸ *See H-D U.S.A., LLC v. SunFrog, LLC*, 311 F. Supp. 3d 1000 (E.D. Wis.), *appeal dismissed*, No. 18-2073, 2018 WL 6039900 (7th Cir. July 19, 2018).

“motorcycles, motorcycle parts and accessories, and various other products and services, including apparel, mugs, and posters”.¹³²⁹



The court agreed the marks were famous long before the defendants’ imitation of them, citing in part the marks’ continuous, long-standing, and geographically widespread use.¹³³⁰ It also found convincing the sale of “many billions of dollars of products and services under these marks, and [expenditure of] many millions of dollars extensively promoting them.”¹³³¹ The marks’ attraction of “wide and unsolicited media attention” also weighed in the plaintiffs’ favor,¹³³² as did the numerous registrations covering them, for many of which the plaintiffs had filed declarations of incontestability.¹³³³ Although the lead defendant opined in response to the plaintiffs’ showing that it was “doubtful” that “two-letter marks such as H–D and HD could obtain the household recognition needed to be considered famous for the purposes of a dilution analysis,” the court held their unsupported speculation on the issue insufficient to create a factual dispute precluding summary judgment in the plaintiffs’ favor.¹³³⁴

Another invocation of Section 43(c) produced a finding that the VERSACE mark for clothing and fashion accessories was sufficiently famous as a matter of law to qualify for the statute’s protection.¹³³⁵ As the court summarized the summary judgment record on the subject, “[the lead plaintiffs’] evidence is undisputed, and establishes that [the lead plaintiff] has used its marks for decades, engages in extensive advertising and promotional efforts in furtherance of the Versace brand, is widely recognized by consumers for the Versace name, and enjoys a high volume of

¹³²⁹ *Id.* at 1011.

¹³³⁰ *Id.* at 1042.

¹³³¹ *Id.*

¹³³² *Id.*

¹³³³ *Id.*

¹³³⁴ *Id.* at 1043.

¹³³⁵ See *Gianni Versace, S.p.A. v. Versace 19.69 Abbigliamento Sportivo SRL*, 328 F. Supp. 3d 1007 (N.D. Cal. 2018), *appeal dismissed*, No. 19-15188, 2019 WL 2005744 (9th Cir. Apr. 17, 2019).

domestic sales.”¹³³⁶ Indeed, the court noted, “[e]ven [an individual defendant] has testified, as [the lead defendant’s] corporate representative, that ‘the Versace name was made famous in the fashion industry by [the lead plaintiff].’”¹³³⁷

So too did the Museum of Modern Art successfully establish the fame of its MoMA mark in the context of a preliminary injunction motion.¹³³⁸ The Museum’s victory on that issue was never seriously in doubt based on its showings of, among other things: (1) the use of its mark “for the lengthy period of nearly 50 years”;¹³³⁹ (2) “substantial publicity” for the mark “across the country”;¹³⁴⁰ (3) “nearly 12 million visitors between 2014 and 2017” alone;¹³⁴¹ (4) “13 million unique visitors” to its website during the preceding year;¹³⁴² (5) the mark’s display “on the Museum’s Twitter, Instagram, and Facebook social media accounts, which have attained millions of followers,” as well as on signs, brochures, communications with the public, and merchandise;¹³⁴³ (6) the Museum’s promotion of the mark “in national publications such as The New York Times, The Wall Street Journal, The Art, The New Yorker, Even, Sculpture, Art in America, Artforum International, Variety, and Hollywood Reporter”;¹³⁴⁴ (7) favorable third-party media coverage of the mark (and not just the Museum);¹³⁴⁵ (8) the “significant amount and wide range of goods and services [offered] under [the] mark”;¹³⁴⁶ and (9) the Museum’s ownership of “numerous federal registrations.”¹³⁴⁷

(b) Opinions Declining to Find Mark Fame and Distinctiveness

The past year produced two conspicuous flameouts among plaintiffs ambitiously claiming fame for relatively obscure marks. These included the federal registrant of the READ A MILLION WORDS, MILLION DOLLAR READER, MILLIONAIRE READER, and MILLIONAIRE’S READING CLUB marks for the promotion of literacy among low-income and English-as-a-second-language

¹³³⁶ *Id.* at 1023.

¹³³⁷ *Id.*

¹³³⁸ *See* Museum of Modern Art v. MOMACHA IP LLC, 339 F. Supp. 3d 361 (S.D.N.Y. 2018).

¹³³⁹ *Id.* at 381.

¹³⁴⁰ *Id.*

¹³⁴¹ *Id.*

¹³⁴² *Id.*

¹³⁴³ *Id.*

¹³⁴⁴ *Id.*

¹³⁴⁵ *Id.*

¹³⁴⁶ *Id.*

¹³⁴⁷ *Id.*

students and related promotional goods.¹³⁴⁸ Reviewing the record on appeal from the district court’s grant of a defense motion for summary judgment, the Fifth Circuit found “no evidence . . . that [the plaintiff’s] marks are widely known among educators, never mind the general consuming public. On the contrary, the evidence shows that [the plaintiff] conducts 87 percent of its business in a single Texas school district.”¹³⁴⁹ With the plaintiff’s case further hindered by the use of identical or similar marks by “several” third parties, “no reasonable jury could find [the plaintiff’s] marks are famous and distinct, so the district court properly granted summary judgment to [the defendant] on this issue.”¹³⁵⁰

The claimed owners of the ST. ROCHE MARKET mark for a public food market suffered a similar fate.¹³⁵¹ The court summarized their allegations of mark fame in the following manner: “Plaintiffs do not allege any advertising of St. Roch Market. Nor do they allege the amount, volume, or geographic extent of sales. The only allegation bearing on the mark’s recognition is that the mark is ‘famous and well-known throughout the New Orleans area.’”¹³⁵² The court found this treatment deficient as a matter of law, and it therefore granted the defendants’ motion to dismiss with the explanation that “[t]his conclusory allegation does not suffice to raise the plausible inference that the mark is ‘is widely recognized by the general consuming public of the United States.’”¹³⁵³

(2) Actual or Likely Dilution

(a) Actual or Likely Dilution by Blurring

Section 43(c)(2)(B) of the Act fleshes out the federal likelihood-by-dilution-blurring cause of action by reciting that “‘dilution by blurring’ is association arising from the similarity between a mark or trade name and a famous mark that impairs the distinctiveness of the famous mark.”¹³⁵⁴ The same section goes on to provide that:

In determining whether a mark or trade name is likely to cause dilution by blurring, the court may consider all relevant factors, including the following:

¹³⁴⁸ See *Springboards to Educ., Inc. v. Hous. Indep. Sch. Dist.*, 912 F.3d 805 (5th Cir. 2019), *as revised* (Jan. 29, 2019), and *as revised* (Feb. 14, 2019).

¹³⁴⁹ *Id.* at 818.

¹³⁵⁰ *Id.*

¹³⁵¹ See *Helpful Hound, L.L.C. v. New Orleans Bldg. Corp.*, 333 F. Supp. 3d 593 (E.D. La. 2018).

¹³⁵² *Id.* at 602.

¹³⁵³ *Id.* (quoting 15 U.S.C. § 1125(c)(2)(A) (2018)).

¹³⁵⁴ 15 U.S.C. § 1125(c)(2)(B) (2018).

- (i) The degree of similarity between the mark or trade name and the famous mark.
- (ii) The degree of inherent or acquired distinctiveness of the famous mark.
- (iii) The extent to which the owner of the famous mark is engaging in substantially exclusive use of the mark.
- (iv) The degree of recognition of the famous mark.
- (v) Whether the user of the mark or trade name intended to create an association with the famous mark.
- (vi) Any actual association between the mark or trade name and the famous mark.¹³⁵⁵

In a case in which motorcycle manufacturer Harley-Davidson and its trademark holding company successfully demonstrated the lead defendant's liability for counterfeiting and infringement as a matter of law, the court added to that defendant's troubles by additionally granting the plaintiff's motion for summary judgment under Section 43(c)(2)(B).¹³⁵⁶ The summary judgment record demonstrated beyond material dispute that the lead defendant had made available for sale through its online marketplace goods bearing spurious copies of the plaintiffs' mark. Based on that record, the court's analysis of the plaintiffs' claim of blurring was short and to the point: "Here, [the lead defendant] used identical or materially indistinguishable variations of the Famous Marks, those marks are distinctiveness and famous, and [the lead defendant] intended to create an association with the Famous Marks to trade on Harley-Davidson's fame and goodwill."¹³⁵⁷

A similar finding of unlawful likely blurring as a matter of law resulted from a summary judgment motion filed by the owner of the VERSACE mark for clothing and various other fashion items.¹³⁵⁸ The defendants' mark, used in connection with similar, but lower-priced goods, was VERSACE 19.69 ABBIGLIAMENTO SPORTIVO, S.R.L., which the court deemed sufficiently similar to the lead plaintiff's mark to support a finding of liability under the first of Section 43(c)(2)(B)'s factors.¹³⁵⁹ The other factors also fell into line in the lead plaintiff's favor: (1) the lead plaintiff's mark was highly distinctive and well recognized;¹³⁶⁰ (2) "[the lead plaintiff] has acted

¹³⁵⁵ *Id.*

¹³⁵⁶ See *H-D U.S.A., LLC v. SunFrog, LLC*, 311 F. Supp. 3d 1000 (E.D. Wis.), *appeal dismissed*, No. 18-2073, 2018 WL 6039900 (7th Cir. July 19, 2018).

¹³⁵⁷ *Id.* at 1044.

¹³⁵⁸ See *Gianni Versace, S.p.A. v. Versace 19.69 Abbigliamento Sportivo SRL*, 328 F. Supp. 3d 1007 (N.D. Cal. 2018), *appeal dismissed*, No. 19-15188, 2019 WL 2005744 (9th Cir. Apr. 17, 2019).

¹³⁵⁹ *Id.* at 1023.

¹³⁶⁰ *Id.*

defensively to protect its marks, and tightly controls its diffusion lines”;¹³⁶¹ (3) “[the lead defendant] has attempted to evoke the Versace design and baroque aesthetic”;¹³⁶² and (4) the lead plaintiff’s submission of anecdotal and survey evidence of actual confusion demonstrated an actual association between the parties’ marks.¹³⁶³

So too did a motion for summary judgment filed by the City of New York lead to a finding as a matter of law that a former licensee’s continued use of the TAVERN ON THE GREEN mark for restaurant and bar services, cooking oil, and salad dressing on a post-termination basis was likely to dilute that mark’s distinctiveness.¹³⁶⁴ Unusually, the court’s conclusion on the issue turned not on an application of the standard statutory factors but instead on language in the parties’ license reciting that a breach by the licensee would create a presumption of infringement. Based on that language, the court concluded that “[g]iven the parties’ stipulation . . . that a ‘likelihood of consumer confusion shall be presumed to exist’ in the event of a breach, there can be little question that the parties’ use of the exact same name to refer to different sources of similar products (*i.e.*, restaurant services) will amount to dilution by blurring.”¹³⁶⁵

In contrast, a New York federal district court denied a motion for summary judgment of liability under Section 43(c) and the New York statute filed by entertainer Beyoncé and one of her companies against defendants using the FEYONCÉ mark to sell clothing featuring quotations from her songs.¹³⁶⁶ The court noted that several of Section 43(c)(2)(B)’s factors “certainly lean[ed]” in the plaintiffs’ favor: “Plaintiffs are engaging in exclusive use of the famous mark, which is highly recognizable, it seems clear on the face of the record that Defendants sought to associate their mark with Plaintiffs’, and Plaintiffs’ [sic] have presented evidence that consumers do indeed associate the FEYONCÉ mark with BEYONCÉ.”¹³⁶⁷ Nevertheless, accepting the defendants’ pronunciation of their mark as “fiancé,” it found from the summary judgment record that:

Defendants’ mark could be considered a pun—it is clearly a reference to Plaintiff Beyoncé, but it is just as clearly a signifier of a specific relationship status. . . . [B]ecause Defendants’ [sic] have not merely co-opted the BEYONCÉ mark, but rather repurposed it in a way that can be

¹³⁶¹ *Id.*

¹³⁶² *Id.*

¹³⁶³ *Id.* at 1024.

¹³⁶⁴ *See City of N.Y. v. Tavern on the Green Int’l LLC*, 351 F. Supp. 3d 680 (S.D.N.Y. 2018).

¹³⁶⁵ *Id.* at 696.

¹³⁶⁶ *See Knowles-Carter v. Feyonce, Inc.*, 347 F. Supp. 3d 217 (S.D.N.Y. 2018).

¹³⁶⁷ *Id.* at 228.

distinguished from the original, a reasonable factfinder could also conclude that there is little risk of dilution.¹³⁶⁸

The court's denial of the plaintiffs' motion under New York law was even more generous to the defendants: Ignoring the distinguishable nature of causes of action for infringement, on the one hand, and likely dilution, on the other, it concluded that factual disputes with respect to the former precluded liability as a matter of law under the latter.¹³⁶⁹

Another plaintiff was even less fortunate in an application of the New York dilution statute.¹³⁷⁰ Although the defendants failed to respond to the complaint or the resulting motion for a default judgment, that did not prevent them from prevailing in the likelihood-of-dilution inquiry, which the court determined was properly governed by an application of the following factors: (1) the similarity of the marks; (2) the similarity of the products covered; (3) the sophistication of the consumers; (4) the existence of predatory intent; (5) the renown of the senior mark; and (6) the renown of the junior mark.¹³⁷¹ It was the first of these that tripped up the plaintiff's case. Holding that "[a] plaintiff cannot prevail on a state or federal dilution claim unless the marks at issue are 'very' or 'substantially similar,'" ¹³⁷² the court found the parties' respective marks—THE BOLD LOOK OF KOHLER, BOLD.POWER., BOLD.PERFORMANCE., BOLD.CONSERVATION., BOLD.STYLE., BOLD.DURABILITY., BOLD.EXPERIENCE., and LIVE BOLD vs. BOLD—sufficiently distinguishable as to preclude liability. As it explained, "plaintiff fails to plead facts or proffer evidence supporting a reasonable inference for any other meaningful degree of similarity, particularly any visual or, more importantly, contextual similarity, thereby foreclosing plaintiff's claim for New York trademark dilution."¹³⁷³

Finally, in an even more improbable defense victory on summary judgment, a pair of defendants in the themed entertainment party business successfully defeated a challenge to their use of costumed characters clearly based on those in the Star Wars, Disney, and

¹³⁶⁸ *Id.*

¹³⁶⁹ *Id.* at 229 ("As previously discussed, the Court concluded that factual questions related to the [Second Circuit's likelihood-of-confusion] factors preclude a finding of likelihood of confusion as a matter of law. Therefore, Plaintiffs' motion for summary judgment on its New York trademark dilution claim is also denied.")

¹³⁷⁰ See *Kohler Co. v. Bold Int'l FZCO*, 127 U.S.P.Q.2d 1459 (E.D.N.Y. 2018), *report and recommendation adopted in relevant part*, No. 17-cv-4233 (LDH) (RLM), 2018 WL 4804655 (E.D.N.Y. Oct. 4, 2018).

¹³⁷¹ *Id.* at 1481.

¹³⁷² *Id.* (alteration in original) (quoting *Playtex Prods., Inc. v. Ga.-Pac. Corp.*, 390 F.3d 158, 162 (2d Cir. 2004)).

¹³⁷³ *Id.*

Marvel universes.¹³⁷⁴ As in the opinion discussed immediately above, the court invoked a six-factor test to hold the defendants entitled to prevail as a matter of law. In applying it, it found that the defendants' deliberate emulation of the plaintiffs' characters in a closely related context—appearances of the plaintiffs' characters at theme parks vs. appearances of the defendants' characters at *privae parties*—weighed *against* a finding of liability:

Plaintiffs do not allege that Defendants coopt [sic] their marks in connection with unrelated products, like “Frozen Snow Boots” or “Avengers Chewing Gum.” Rather, they claim Defendants use Plaintiffs' marks in connection with the provision of character-for-hire services in a manner that specifically evokes Plaintiffs' characters. Accordingly, Plaintiffs have not shown that their marks “will lose [their] ability to serve as a unique identifier of [their] produce[s]” as a result of Defendants' conduct.¹³⁷⁵

Immediately after this observation, the court found it beyond material dispute that “there is some measure of difference in the way Defendants use and present Plaintiffs' marks, and a substantial dissimilarity between the types of goods and services offered by Plaintiffs and Defendants”;¹³⁷⁶ likewise, the defendants' use of disclaimers of affiliation precluded findings of bad faith and predatory intent.¹³⁷⁷ With the summary judgment record reflecting “no evidence regarding the sophistication level of the relevant consumers,”¹³⁷⁸ as well as “no evidence as to Defendants' renown, it seems improbable Defendants' marks' will ‘become so famous that [they] will overwhelm' Plaintiffs' mark and cause Plaintiffs' ‘consumers to draw the associations identified with' Defendants' marks.”¹³⁷⁹

(b) Actual or Likely Dilution by Tarnishment

As defined by Section 43(c)(2)(C) of the Act, “dilution by tarnishment” is an “association arising from the similarity between a mark or trade name and a famous mark that harms the reputation of the famous mark.”¹³⁸⁰ Some plaintiffs succeeded in proving liability under that standard, not the least of which were motorcycle

¹³⁷⁴ See *Disney Enters. v. Sarelli*, 322 F. Supp. 3d 413 (S.D.N.Y. 2018), *reconsideration denied*, No. 16 CIV. 2340 (GBD), 2018 WL 5019745 (S.D.N.Y. Sept. 26, 2018).

¹³⁷⁵ *Id.* at 440 (alterations in original) (quoting *N.Y. Stock Exch., Inc. v. N.Y., N.Y. Hotel LLC*, 293 F.3d 550, 558 (2d Cir. 2002)).

¹³⁷⁶ *Id.*

¹³⁷⁷ *Id.*

¹³⁷⁸ *Id.*

¹³⁷⁹ *Id.*

¹³⁸⁰ 15 U.S.C. § 1125(c)(2)(C) (2018).

manufacturer Harley-Davidson and its trademark holding company.¹³⁸¹ Those plaintiffs successfully challenged the unauthorized use of their marks on merchandise sold through an online marketplace operated by the lead defendant as likely to tarnish the marks' distinctiveness. To begin with, the court noted in granting the plaintiffs' motion for summary judgment, "[the] cheaply made, knockoff products [available on the lead defendant's website] fall well below the quality standards that Harley–Davidson has long set for its licensees, harming its reputation with the purchasing public."¹³⁸² Moreover, and as a separate basis for liability:

[E]ven if [those] products met Harley–Davidson's quality control standards, many of them would not meet its content criteria. Many of the offending products include vulgar, political, or religious content that Harley–Davidson would not have approved to appear on licensed products. Others modify or mutilate the H–D Marks, or display marks that Harley–Davidson does not license, which again Harley–Davidson would not have approved of. There is perhaps no greater tarnishment of a famous brand than using it in an unauthorized way that likely will offend potential purchasers of genuine goods.¹³⁸³

Cheap and shoddy products led to another finding of likely dilution by tarnishment in an action brought by the owner of the VERSACE mark for clothing and various related goods and a licensee of that mark against the purveyors of similar products under the VERSACE 19.69 ABBIGLIAMENTO SPORTIVO, S.R.L. mark.¹³⁸⁴ In support of a motion for summary judgment, the lead plaintiff submitted "expert testimony and consumer complaints detailing the poor quality of [the defendants'] products and workmanship."¹³⁸⁵ Based on that showing, the court placed upon the defendants the burden of proving their goods were not inferior, which they purported to do by citing a 1 percent return rate among purchases of the plaintiffs' goods. Unconvinced, the court observed that "[the defendants] fail[] to explain the relationship between [the plaintiffs'] return rate and [their] product quality. [The defendants] also do[] not present evidence of, or even assert, [their] own rate of product return. It is accordingly unclear why this fact is material,

¹³⁸¹ See *H-D U.S.A., LLC v. SunFrog, LLC*, 311 F. Supp. 3d 1000 (E.D. Wis.), *appeal dismissed*, No. 18-2073, 2018 WL 6039900 (7th Cir. July 19, 2018).

¹³⁸² *Id.* at 1044.

¹³⁸³ *Id.* at 1044-45.

¹³⁸⁴ See *Gianni Versace, S.p.A. v. Versace 19.69 Abbigliamento Sportivo SRL*, 328 F. Supp. 3d 1007 (N.D. Cal. 2018), *appeal dismissed*, No. 19-15188, 2019 WL 2005744 (9th Cir. Apr. 17, 2019).

¹³⁸⁵ *Id.* at 1024.

even if it is disputed.”¹³⁸⁶ “Summary judgment,” it concluded, “is appropriate on [the plaintiffs] tarnishment theory.”¹³⁸⁷

Although not reaching an actual finding of liability under the New York dilution statute,¹³⁸⁸ a New York federal district court similarly found evidence of shoddy quality sufficient to defeat a defense motion for summary judgment even if the same evidence was an insufficient basis for a grant of the plaintiffs’ own motion.¹³⁸⁹ The plaintiffs’ showing on the issue consisted of “three customer complaints . . . filed with the Better Business Bureau (‘BBB’) against [Defendants] since 2014, resulting in the BBB giving [Defendants] an ‘F’ rating,”¹³⁹⁰ as well their receipt of “at least seventeen unfavorable reviews on its Yelp webpage commenting on Defendants’ allegedly rude and unprofessional treatment of its [sic] customers.”¹³⁹¹ “Yet,” the court observed, “the evidence in the record demonstrates that [Defendants] receive[] many positive reviews for [their] services, as well.”¹³⁹² Against that backdrop of conflicting evidence, “a genuine issue of material fact exists as to whether Defendants’ use of Plaintiffs’ mark is likely to cause a diminution in the reputation or value of Plaintiffs’ marks.”¹³⁹³

In contrast, however, a court from the same federal district denied a motion for summary judgment of liability under the dilution statute of that state, which a group of plaintiffs invoked while claiming rights to the registered MARILYN mark for various goods, including clothing.¹³⁹⁴ The counterclaim plaintiffs’ action targeted the use of the same mark on clothing featuring Marilyn Monroe’s image, and they sought to establish a presumption of likely dilution under New York law by arguing that the parties’ uses were identical. Citing differences in the parties’ respective presentations, the court disagreed, holding that “for the presumption of dilution to apply, the marks must be identical. In other words, a mere similarity in the marks — even a close similarity — will not suffice to establish per se evidence of actual dilution.”¹³⁹⁵ In an equally abbreviated analysis, it then denied the counterclaim defendants’ motion for summary judgment of

¹³⁸⁶ *Id.*

¹³⁸⁷ *Id.*

¹³⁸⁸ N.Y. Gen. Bus. Law § 360-1 (McKinney 2012).

¹³⁸⁹ *See* Disney Enters. v. Sarelli, 322 F. Supp. 3d 413 (S.D.N.Y. 2018), *reconsideration denied*, No. 16 CIV. 2340 (GBD), 2018 WL 5019745 (S.D.N.Y. Sept. 26, 2018).

¹³⁹⁰ *Id.* at 427.

¹³⁹¹ *Id.*

¹³⁹² *Id.* at 437.

¹³⁹³ *Id.* at 441.

¹³⁹⁴ *See* A.V.E.L.A., Inc. v. Estate of Marilyn Monroe, LLC, 364 F. Supp. 3d 291 (S.D.N.Y. 2019).

¹³⁹⁵ *Id.* at 316.

nonliability under Section 43(c). As it explained, “the [counterclaim plaintiffs] are entitled to present evidence that customers expect the products [bearing the MARILYN mark and her image and sold by the counterclaim defendants] to carry the [counterclaim plaintiffs’] endorsement and that the products . . . risk damaging the [counterclaim plaintiffs’] brand by tarnishing the Monroe persona in which they hold ownership.”¹³⁹⁶

(E) Cybersquatting

The Anticybersquatting Consumer Protection Act (ACPA) authorizes both in rem and in personam actions in challenges to domain names that allegedly misappropriate trademarks and service marks.¹³⁹⁷ If a prior arbitration proceeding under the Uniform Dispute Resolution Policy (UDRP) has resulted in the suspension, transfer, or disabling of a domain name, the ACPA also authorizes what is effectively a mechanism for the domain name registrant to appeal the outcome of the UDRP action by bringing a cause of action for reverse domain name hijacking.¹³⁹⁸

(1) In Rem Actions

As has been increasingly the case in recent years, there were no readily reported opinions arising from in rem actions under the ACPA.

(2) In Personam Actions

Where in personam actions are concerned, the ACPA generally provides for civil liability if a plaintiff can prove (1) the defendant registered, trafficked in, or used a domain name; (2) the domain name is identical or confusingly similar to a protected mark owned by the plaintiff; and (3) the defendant acted with a bad-faith intent to profit from that mark. The last of these requirements is governed by nine factors found in Section 43(d)(1)(B)(i) of the Lanham Act,¹³⁹⁹ and is subject to a carve-out found in Section 43(d)(1)(B)(ii), which provides that “[b]ad faith intent . . . shall not be found in any case in which the court determines that the person believed and had reasonable grounds to believe that the use of the domain name was a fair use or otherwise lawful.”¹⁴⁰⁰

¹³⁹⁶ *Id.* at 317.

¹³⁹⁷ *See* 15 U.S.C. § 1125(d) (2018).

¹³⁹⁸ *See id.* § 1114(2)(D)(v).

¹³⁹⁹ 15 U.S.C. § 1125(d)(1)(B)(i)(I)-(IX) (2018).

¹⁴⁰⁰ *Id.* § 1125(d)(1)(B)(ii).

Despite the general requirement of use in commerce for protectable rights, the operative language of Section 43(d)(1)(A)¹⁴⁰¹ conspicuously omits prior use (as opposed to prior distinctiveness) as a prerequisite for liability in an *in rem* action for cybersquatting. It provides:

A person shall be liable in a civil action by the owner of a mark . . . that person . . . has a bad faith intent to profit from that mark . . . and . . . registers, traffics in, or uses a domain name that . . . in the case of a mark that is distinctive at the time of registration of the domain name, is identical or confusingly similar to that mark.¹⁴⁰²

Based on that omission, one plaintiff argued that the defendants' preemptive registration of a domain name incorporating the plaintiff's inherently distinctive mark was actionable even if the registration took place prior to the plaintiff's use of his mark.¹⁴⁰³ The court disagreed, and it therefore dismissed the plaintiff's complaint for failure to state a claim. Although acknowledging "there is no explicit use requirement related to the time of the domain registration,"¹⁴⁰⁴ the court nevertheless held that "an obvious implication from the text of the statute is that there must be a 'mark' capable of being distinctive at the time of registration."¹⁴⁰⁵ Referring to the definition of "trademark" set forth in Section 45 of the Act, it ultimately concluded that "the Court presumes that [Section 43(d)(1)(A)] operates consistently with the fundamental principle of trademark law that '[a]ctual substantive rights to a trademark arise based on its *use* in commerce and its distinctiveness."¹⁴⁰⁶

In a more conventional case under the ACPA, an application of Section 43(d)(1)(B)(i)'s factors led to a finding of liability for a group of defendants with the deck heavily stacked against them.¹⁴⁰⁷ The summary judgment record demonstrated that in 2008, having learned of the plaintiff's dissolution of a subsidiary, the defendants registered two domain names incorporating a mark owned by the subsidiary. They subsequently changed the address of record for federal registrations covering the mark through spurious filings in the USPTO before establishing a website accessible at both domain names on which they falsely claimed credit for major construction

¹⁴⁰¹ *Id.* § 1125(d)(1)(A).

¹⁴⁰² *Id.*

¹⁴⁰³ *See* *Thompson v. Does 1-5*, 376 F. Supp. 3d 1322 (N.D. Ga. 2019).

¹⁴⁰⁴ *Id.* at 1326.

¹⁴⁰⁵ *Id.*

¹⁴⁰⁶ *Id.* (alteration in original) (quoting *FN Herstal SA v. Clyde Armory Inc.*, 838 F.3d 1071, 1080 (11th Cir. 2016)).

¹⁴⁰⁷ *See* *AECOM Energy & Constr., Inc. v. Ripley*, 348 F. Supp. 3d 1038 (C.D. Cal. 2018), *reconsideration denied*, No. CV 17-5398-RSWL-SSx, 2019 WL 2610953 (C.D. Cal. Apr. 24, 2019), *appeal docketed*, No. 19-55588 (9th Cir. May 23, 2019).

projects on which the plaintiff and its subsidiary had worked. If this were not enough, they also petitioned for the revival of the subsidiary through fraudulent filings in which they represented they were acting on behalf of the subsidiary's management. Finally, in 2016, they procured their own federal registration of the primary mark at issue through what the court determined to be fraudulent representations to the USPTO.

In the face of this rather overwhelming evidence of bad faith, the defendants advanced the feeble argument that their ownership of registrations covering the plaintiff's marks precluded a finding they had violated the ACPA. That contention failed to sway the court, which concluded instead that "[t]he current trademark holder has no bearing on whether in 2008, when Defendants registered the domain names, they were identical to a distinctive mark. At that time, Plaintiff held a valid registered trademark Defendant[s] . . . Corporation did not obtain [its own] trademark registration in [the same mark] until 2016."¹⁴⁰⁸ In light of the "ample evidence of each Defendants' bad faith intent to profit," the plaintiff's entitlement to summary judgment was beyond material dispute.¹⁴⁰⁹

In contrast, some courts did not resolve the merits of the ACPA claims before them as a matter of law. For example, one opinion applying Section 43(d)(1)(B)(i)'s factors on cross-motions for summary judgment declined to find that cybersquatting had or had not occurred.¹⁴¹⁰ The opinion began in promising fashion for the defendants in light of the court's conclusion that the plaintiff's geographically descriptive marks lacked the acquired distinctiveness required for them to be protectable prior to the defendants' initial registrations of a number of domain names based on the plaintiff's marks. But the defendants ill-advisedly allowed their registrations to renew automatically after the USPTO registered the plaintiff's marks on the Principal Register, and that exposed them to potential liability. Moreover, the court had no difficulty concluding as a matter of law that the domain names were confusingly similar to the plaintiff's marks.

That left the issue of whether a bad-faith intent to profit had motivated the defendants' conduct. Despite its earlier holding that the plaintiff had no protectable rights at the times of at least some of the defendants' actions, the court considered those same actions when evaluating the defendants' intent. The plaintiff's showing on that question included such considerations as: (1) the absence of any rights by the defendants to the domain names; (2) the fact that the domain names did not correspond to the defendants' legal names;

¹⁴⁰⁸ *Id.* at 1058.

¹⁴⁰⁹ *Id.*

¹⁴¹⁰ See ZP No. 314, LLC v. ILM Capital, LLC, 335 F. Supp. 3d 1242 (S.D. Ala. 2018).

(3) the lack of noncommercial or fair use of the domain names by the defendants; (4) the defendants' intent to divert potential customers of the plaintiff's services to the defendant's competitive business; (5) the defendants' reregistration of the domain names with the knowledge of the domain names' similarity to the plaintiff's marks; and (6) the distinctiveness of the plaintiff's marks.¹⁴¹¹ Rather improbably, the court held that, although the plaintiff had demonstrated the defendants' bad faith, a factual question remained as to their intent to profit from their actions. In reaching this conclusion, the court credited the defendants' assertion that they had only reregistered the domain names to maintain the status quo during the pendency of the litigation, which it noted "simply places [the] issue in dispute."¹⁴¹²

Another plaintiff—a law firm operating under the MCALLISTER OLIVARIUS mark—successfully shot down a motion to dismiss its cybersquatting claim against a former client who had registered the mcallisterolivariustruth.com domain name.¹⁴¹³ The defendant argued that the "truth" component of its domain name necessarily communicated an intent to criticize the plaintiff, but the court held to the contrary that "[o]n its face, the word 'truth,' added to the name 'mcallisterolivarius,' is not (unlike 'sucks') so self-evidently intended as criticism as to warrant dismissal on a motion to dismiss, where every reasonable inference must be drawn in favor of plaintiff."¹⁴¹⁴ The court also credited the plaintiff's allegations that the defendant had registered the disputed domain name in the context of a fee dispute and that he "sought to profit by diverting customers to his website and then offering to plaintiff that he would refrain from posting true but purportedly damaging documents on that domain name for a price."¹⁴¹⁵ That conduct, the court concluded, "is . . . well within the plain meaning of the words 'a bad faith intent to profit from th[e] mark,' and accordingly meets the requirements of the statute."¹⁴¹⁶ "Finally," it observed in declining to dismiss the plaintiff's ACPA claim, "even if [the defendant's] blackmail . . . warrant[ed] First Amendment protection, courts have held that the First Amendment does not protect the use of a trademark in a domain name that creates a likelihood of confusion as to the source or sponsorship of the attached website."¹⁴¹⁷

¹⁴¹¹ *Id.* at 1261-62.

¹⁴¹² *Id.* at 1264.

¹⁴¹³ See *McAllister Olivarius v. Mermel*, 298 F. Supp. 3d 661 (S.D.N.Y. 2018).

¹⁴¹⁴ *Id.* at 672.

¹⁴¹⁵ *Id.* at 675.

¹⁴¹⁶ *Id.* (second alteration in original).

¹⁴¹⁷ *Id.* at 676.

b. Passing Off and Reverse Passing Off

i. Passing Off

The only readily apparent reported opinion to address the tort of passing off in any detail¹⁴¹⁸ did so in the context of an unsuccessful motion to dismiss.¹⁴¹⁹ Denying the motion, the court noted averments in the plaintiffs' complaint that the defendants had displayed a hospital bed manufactured by the plaintiffs at trade shows and advertised the same bed on their website. Beyond that allegation, the complaint also averred that, when displaying their own bed at trade shows, the defendants never displayed the plaintiffs' bed. "Based on these specific allegations," the court held, "the Court may plausibly infer under Rule 9(b) that Defendants sought to convince customers that the [bed] on display at their booth was somehow connected to or affiliated with Plaintiffs' [bed]."¹⁴²⁰ Moreover, and contrary to the defendant's argument on the issue, an averment of actual confusion was unnecessary to set forth a prima facie case of passing off.¹⁴²¹

ii. Reverse Passing Off

Since 2003, the Supreme Court's restrictive interpretation of Section 43(a)(1)(A) of the Act¹⁴²² in *Dastar Corp. v. Twentieth Century Fox Film Corp.*,¹⁴²³ has reduced that section's utility in challenges to reverse passing off unless defendants have taken physical goods originating with plaintiffs and sold them as their own.¹⁴²⁴ Nevertheless, the Ninth Circuit bucked that pattern by affirming a jury finding of reverse passing off in a dispute between purveyors of specialized tires.¹⁴²⁵ The trial record established that the principal of the lead defendant had asked a manufacturer hired by the lead plaintiff to supply his company with tires made from the same mold as the lead plaintiff's tires but from which the lead plaintiff's mark had been removed. The parties disagreed on appeal

¹⁴¹⁸ For an opinion entering a default judgment of passing off based on the defendants' alleged practice of identifying themselves as employees of the plaintiff to gain access to diverted phones sold by the plaintiff, see *Sprint Sols., Inc. v. Lafayette*, 127 U.S.P.Q.2d 1256, 1263 (W.D. Tenn. 2018).

¹⁴¹⁹ See *VitalGo, Inc. v. Kreg Therapeutics, Inc.*, 370 F. Supp. 3d 873 (N.D. Ill. 2019).

¹⁴²⁰ *Id.* at 980.

¹⁴²¹ *Id.*

¹⁴²² 15 U.S.C. § 1125(a)(1)(A) (2018).

¹⁴²³ 539 U.S. 23 (2003).

¹⁴²⁴ Likewise, federal patent law will preempt claims of reverse passing off resting on bare allegations that a defendant has practiced technology in which the plaintiff claims proprietary rights. See, e.g., *Bytemark, Inc. v. Xerox Corp.*, 342 F. Supp. 3d 496, 507 (S.D.N.Y. 2018).

¹⁴²⁵ See *OTR Wheel Eng'g, Inc. v. W. Worldwide Servs., Inc.*, 897 F.3d 1008 (9th Cir. 2018).

as to whether the tires in question were copies of the lead plaintiff's tire (in which case *Dastar* would preclude liability) or, alternatively, whether the rogue manufacturer had produced them in anticipation of an order by the lead plaintiff (in which case it might not). As had the jury, the court sided with the plaintiffs, concluding that the jury's finding that the case fell within the first scenario was not clearly erroneous.¹⁴²⁶ With enough evidence and testimony in the record to support the jury's concomitant findings that the defendants had orchestrated the removal of the lead plaintiff's mark from the tires,¹⁴²⁷ and that the defendants' conduct had produced likely confusion in the marketplace,¹⁴²⁸ the judgment of reverse passing off below withstood appellate scrutiny.

The D.C. Circuit also affirmed a district court's rejection of a defendant's invocation of *Dastar*.¹⁴²⁹ That defendant was a non-profit organization with a goal of reproducing technical standards with the force of law and making them accessible online. The defendant argued that the plaintiffs' infringement claim—made possible by the defendant's display of the plaintiffs' marks in conjunction with the reproduced copies—was an attempted impermissible end run around the limitations of the Copyright Act, but the court disagreed. It noted the plaintiffs did not merely accuse the defendant of making exact copies of the plaintiffs' standards; rather, they averred the defendant had created the reproductions through a combination of scanning and retyping “with resultant errors and differences.”¹⁴³⁰ According to the court, “[c]onsumers who download copies of the standards from [the defendant's] website may not only be misled into thinking that [the plaintiffs] produced the digital files but also may attribute any errors to [the plaintiffs].”¹⁴³¹ “This,” the court held, “risks precisely the sort of confusion as to ‘the producer of the tangible product sold in the marketplace’ that the Supreme Court in *Dastar* deemed a cognizable injury under the Lanham Act.”¹⁴³² The district court therefore had been correct to proceed to the merits of the plaintiffs' claims of infringement.

¹⁴²⁶ *Id.* at 1017.

¹⁴²⁷ *Id.* at 1018.

¹⁴²⁸ *Id.* at 1018-19.

¹⁴²⁹ *See* *Am. Soc'y for Testing & Materials v. Public.Resource.Org, Inc.*, 896 F.3d 437 (D.C. Cir. 2018).

¹⁴³⁰ *Id.* at 455.

¹⁴³¹ *Id.*

¹⁴³² *Id.* (quoting *Dastar*, 539 U.S. at 31).

In contrast, a claim of reverse passing off failed as a matter of law at the hands of a New York federal district court.¹⁴³³ The plaintiffs manufactured safety systems for electrically operated folding partitions. The gravamen of their reverse passing off cause of action was that contractors hired to maintain the plaintiffs' systems affixed stickers bearing the contractors' name to the systems. The court did not view that practice as reverse passing off, and it therefore granted a defense motion for summary judgment:

[A]ffixing a sticker on the [plaintiffs'] System does not create confusion with respect to the origin of the . . . System—the stickers are meant to promote [the defendants'] maintenance and repair services. As the plaintiffs themselves wrote, the sticker is affixed on the . . . System by the [defendants] “in order to promote their *maintenance and repair* services.” The plaintiffs have not provided evidence to support their assertion that the affixing of the stickers causes confusion about the origin of the Safe Path System, as opposed to merely providing advertising of [the defendants'] maintenance business.¹⁴³⁴

A Tennessee federal district disposed of another claim of reverse passing off in even more aggressive fashion.¹⁴³⁵ Indeed, although liability under that tort is generally a question of fact, the court dismissed a complaint asserting a reverse passing off cause of action as fatally defective. The gravamen of the plaintiff's complaint was that the defendants had incorporated some of the plaintiff's technology into products produced by the defendants and had then sold those products. This, the court held, failed to state a claim for reverse passing off because such a claim was limited to situations in which a plaintiff's product was sold as that of a defendant.¹⁴³⁶ Responding to the defendants' invocation of *Dastar*, the plaintiff attempted to distinguish the Supreme Court's opinion by arguing its claimed technology was proprietary, while the material at issue in *Dastar* had been in the public domain; the court held instead that, because it applied to all claims concerning the origin of creative content, *Dastar* foreclosed the plaintiff's claim.¹⁴³⁷

¹⁴³³ See *Gym Door Repairs, Inc. v. Young Equip. Sales, Inc.*, 331 F. Supp. 3d 221 (S.D.N.Y.), *reconsideration denied*, No. 15-CV-4244 (JGK), 2018 WL 5650004 (S.D.N.Y. Oct. 30, 2018).

¹⁴³⁴ *Id.* at 250-511 (citation omitted).

¹⁴³⁵ See *Vanderbilt Univ. v. Scholastic, Inc.*, 382 F. Supp. 3d 734 (M.D. Tenn. 2019).

¹⁴³⁶ *Id.* at 757.

¹⁴³⁷ *Id.*

c. False Advertising

Courts generally applied the standard five-part test for false advertising over the past year, which, consistent with the rule in the Northern District of Illinois and the Northern District of California, federal courts in those districts required to be pleaded with particularity.¹⁴³⁸ That test required plaintiffs to show by a preponderance of the evidence and testimony: (1) a false or misleading description of fact or representation of fact by the defendant in a commercial advertisement about its own or another's good or service; (2) the materiality of the misrepresentation; (3) actual or likely deception of a substantial segment of its audience; (4) placement of misrepresentation in interstate commerce; and (5) actual or likely injury of the plaintiff, either by direct diversion of sales or by a lessening of goodwill associated with its products.¹⁴³⁹ In addition to these requirements, one court applied Ninth Circuit law to hold that, "where Lanham Act claims . . . are based on a defendant's representation that someone infringed his patent, plaintiff must show that defendant's representation was made in bad faith,"¹⁴⁴⁰ that court eventually granted a defense

¹⁴³⁸ See *Genus Lifesciences Inc. v. Lannett Co.*, 378 F. Supp. 3d 823, 836 n.4 (N.D. Cal.), *reconsideration denied*, No. 18-cv-07603-WHO, 2019 WL 4168958 (N.D. Cal. Sept. 3, 2019); *VitalGo, Inc. v. Kreg Therapeutics, Inc.*, 370 F. Supp. 3d 873, 891-92 (N.D. Ill. 2019); *Desmond v. Taxi Affiliation Servs. LLC*, 344 F. Supp. 3d 915, 929-30 (N.D. Ill. 2018).

¹⁴³⁹ See, e.g., *Hi-Tech Pharm., Inc. v. HBS Int'l Corp.*, 910 F.3d 1186, 1196 (11th Cir. 2018); *De Simone v. VSL Pharm., Inc.*, 395 F. Supp. 3d 617, 623 (D. Md. 2019), *appeal docketed*, No. 19-1731 (4th Cir. July 19, 2019); *Genus Lifesciences*, 378 F. Supp. 3d at 332-33; *Diamond Resorts Int'l, Inc. v. Aaronson*, 371 F. Supp. 3d 1088, 1101 (M.D. Fla. 2019); *Outlaw Lab., LP v. Shenoor Enter., Inc.*, 371 F. Supp. 3d 355, 362 (N.D. Tex. 2019); *VitalGo*, 370 F. Supp. 3d at 890-91; *Am. Fireglass v. Moderustic, Inc.*, 365 F. Supp. 3d 1062, 1082 (S.D. Cal.), *reconsideration denied*, No. 15-CV-2866 JLS (BGS), 2019 WL 4918042 (S.D. Cal. Oct. 4, 2019), *appeal docketed*, No. 20-1294 (Fed. Cir. Dec. 30, 2019); *Allergan USA, Inc. v. Prescribers Choice, Inc.*, 364 F. Supp. 3d 1089, 1108 (C.D. Cal. 2019); *San Diego Cty. Credit Union v. Citizens Equity First Credit Union*, 360 F. Supp. 3d 1039, 1052 (S.D. Cal. 2019); *BHR Recovery Cmty's., Inc. v. Top Seek, LLC*, 355 F. Supp. 3d 416, 426 (E.D. Va. 2018); *Drone Racing League, Inc. v. DR1, LLC*, 129 U.S.P.Q.2d 1083, 1089 (S.D.N.Y. 2018); *AECOM Energy & Constr., Inc. v. Ripley*, 348 F. Supp. 3d 1038, 1055 (C.D. Cal. 2018), *reconsideration denied*, No. CV 17-5398-RSWL-SSx, 2019 WL 2610953 (C.D. Cal. Apr. 24, 2019), *appeal docketed*, No. 19-55588 (9th Cir. May 23, 2019); *Desmond*, 344 F. Supp. 3d at 929-30; *Nat'l Grange of the Order of Patrons of Husbandry v. Cal. Guild*, 334 F. Supp. 3d 1057, 1066-67 (E.D. Cal. 2018), *reconsideration denied sub nom. Nat'l Grange v. Cal. Guild*, No. 2:16-cv-0201 WBS DB, 2018 WL 5270563 (E.D. Cal. Oct. 22, 2018), *appeal docketed*, No. 18-16671 (9th Cir. Sept. 5, 2018); *Incarcerated Entm't, LLC v. CNBC LLC*, 331 F. Supp. 3d 352, 362 (D. Del. 2018); *Obesity Research Inst., LLC v. Fiber Research Int'l, LLC*, 310 F. Supp. 3d 1089, 1118 (S.D. Cal.), *motion to certify denied*, No. 15-cv-00595-BAS-MDD, 2018 WL 1791611 (S.D. Cal. Apr. 16, 2018); *Sprint Sols., Inc. v. Lafayette*, 127 U.S.P.Q.2d 1256, 1268 (W.D. Tenn. 2018); *Weirton Med. Ctr. v. Introublezone, Inc.*, 193 A.3d 967, 974 (Pa. Sup. Ct. 2018).

¹⁴⁴⁰ *Am. Fireglass*, 365 F. Supp. 3d at 1083 (alteration in original) (quoting *Appliance Recycling Ctrs. of Am., Inc. v. JACO Env'tl., Inc.*, 378 F. App'x 652, 655 (9th Cir. 2010)).

motion for summary judgment after concluding that “[w]ithout a showing that Defendant had some malicious intent, rather than simply asserting its rights as the patentholder, the Court cannot find bad faith present here.”¹⁴⁴¹

Other courts applied alternative tests for liability. For example, and consistent with at least some controlling authority in that jurisdiction, one district court in the Second Circuit adopted a somewhat less complex standard: “To prevail on a false-advertising claim under § 43(a) of the Lanham Act, ‘a plaintiff must show that either: 1) the challenged advertisement is literally false, or 2) while the advertisement is literally true it is nevertheless likely to mislead or confuse consumers;”¹⁴⁴² the court went on to clarify, however, that materiality remained a third prerequisite.¹⁴⁴³ An Illinois federal district court similarly opted out of the standard test in favor of a three-factor one in requiring the plaintiff before it to prove “(1) the defendant made a material false statement of fact in a commercial advertisement; (2) the false statement actually deceived or had the tendency to deceive a substantial segment of its audience; and (3) the plaintiff has been or is likely to be injured as a result of the false statement.”¹⁴⁴⁴ And in a final variation, a Utah federal district court required showings:

- (1) that [the] defendant made material false or misleading representations of fact in connection with the commercial advertising or promotion of its product;
- (2) in commerce;
- (3) that are either likely to cause confusion or mistake as to
 - (a) the origin, association or approval of the product with or by another, or
 - (b) the characteristics of the goods or services;
- and (4) injure the plaintiff.¹⁴⁴⁵

¹⁴⁴¹ *Id.* at 1084.

¹⁴⁴² *In re* Keurig Green Mountain Single-Serve Coffee Antitrust Litig., 383 F. Supp. 3d 187, 247 (S.D.N.Y. 2019) (quoting *Johnson & Johnson * Merck Consumer Pharm. Co. v. Smithkline Beecham Corp.*, 960 F.2d 294, 297 (2d Cir. 1992)).

¹⁴⁴³ *Id.*

¹⁴⁴⁴ *MillerCoors, LLC v. Anheuser-Busch Cos.*, 385 F. Supp. 3d 730, 744 (W.D. Wis.) (quoting *Eli Lilly & Co. v. Arla Foods, Inc.*, 893 F.3d 375, 381-82 (7th Cir. 2018)), *modified*, No. 19-cv-218-wmc, 2019 WL 4187489 (W.D. Wis. Sept. 4, 2019), *and modified*, No. 19-cv-218-wmc, 2019 WL 4247725 (W.D. Wis. Sept. 6, 2019), *remanded on other grounds*, 940 F.3d 922 (7th Cir. 2019).

¹⁴⁴⁵ *Bimbo Bakeries USA, Inc. v. Sycamore*, 372 F. Supp. 3d 1291, 1300 (D. Utah 2019) (quoting *Intermountain Stroke Ctr. v. Intermountain Health Care, Inc.*, 638 Fed. Appx. 778, 784 (10th Cir. 2016)), *appeal docketed*, No. 19-4040 (10th Cir. Mar. 22, 2019).

i. False Statements of Fact in Commercial Advertising and Promotion

(A) Actionable Statements of Fact

To qualify as actionable, a statement challenged as false advertising must be objectively verifiable or, in other words, neither puffery nor a mere opinion.¹⁴⁴⁶ Although photographs do not ordinarily lend themselves to findings of puffery, the Sixth Circuit declined to disturb a finding that the use of the following doctored photograph showing a woodpecker allegedly nesting in a hole in wooden siding of a house was not excusable as puffery:¹⁴⁴⁷

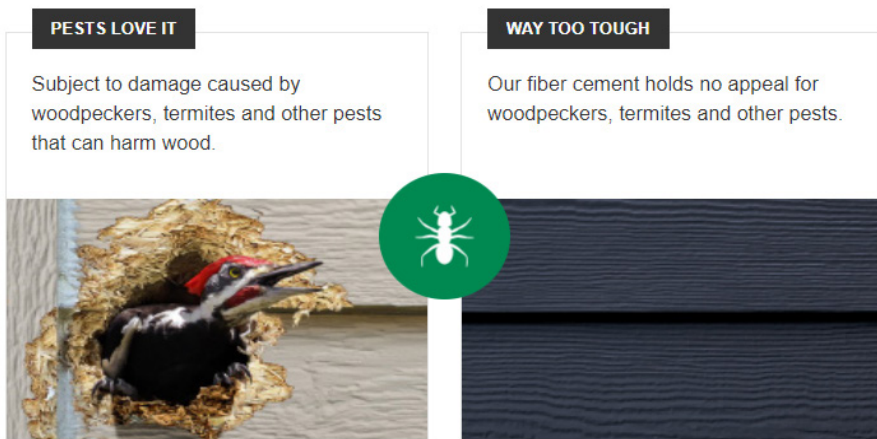

The underlying purpose of the advertisement’s comparison of the wood residential siding sold by the plaintiff and the fiber-cement siding sold by the defendant was to communicate the alleged susceptibility of the former to invasion by pests. Not finding the comparison as humorous as the defendant, the plaintiff sought a preliminary injunction against the advertisement’s continued distribution, but it did so unsuccessfully. The district court found the advertisement nonactionable, and the Sixth Circuit affirmed. According to the appellate court, “[p]uffery protects statements that reasonable consumers would not interpret as reliably factual. No reasonable purchaser would believe that [the defendant] knows—or could discover—whether pests ‘love’ engineered-wood siding.”¹⁴⁴⁸

¹⁴⁴⁶ See, e.g., *Davis v. Avvo, Inc.*, 345 F. Supp. 3d 534, 542 (S.D.N.Y. 2018) (holding as a matter of law that designation of attorneys as “pros” constituted nonactionable puffery); *Incarcerated Entm’t, LLC v. CNBC LLC*, 331 F. Supp. 3d 352, 364 (D. Del. 2018) (granting motion to dismiss challenge to allegedly false statement in the promotion of defendants’ television program on ground that accuracy of statement “is a matter of argument which a viewer may reject or accept after viewing the episode”).

¹⁴⁴⁷ See *La.-Pac. Corp. v. James Hardie Bldg. Prods., Inc.*, 928 F.3d 514, 516 (6th Cir. 2019).

¹⁴⁴⁸ *Id.* at 519 (citation omitted).

The Seventh Circuit also affirmed the dismissal of a false advertising cause of action at the pleadings stage, albeit for a different reason.¹⁴⁴⁹ The case arose from an article authored by a board member of a competing certifying organization that advised readers of a magazine directed toward judges to accept expert testimony only from witnesses with particular credentials (not surprisingly, credentials equivalent to those required by the author's organization). When the magazine's publisher declined to accept for publication an unedited response by the lead plaintiff, the plaintiffs filed suit, alleging that the article falsely implied forensic documents not certified by author's board were unqualified. Like the district court, the Seventh Circuit concluded that the article's content consisted of nothing but nonactionable opinions for purposes of the plaintiff's Section 43(a) and Illinois defamation causes of action. It held:

Nobody reading the article in this context could reasonably have seen [the] statements [in it] as assertions of fact subject to falsification. To the contrary, the article was what it purported to be: one practitioner's commentary on how judges should attend to the admission of expert opinion in the area of handwriting analysis.¹⁴⁵⁰

The district court therefore had properly dismissed the complaint for failure to state a claim.

Puffery and statements of opinions were not the only reasons some claims of actionable statements of fact failed as a matter of law. For example, one unsuccessful false advertising cause of action rested on the averment that the defendant had inaccurately used the ® symbol in conjunction with a mark that was, in fact, not covered by a federal registration.¹⁴⁵¹ Dismissing that cause of action, the court agreed with the defendant that the plaintiff had failed to state a claim. As it noted, allegedly false representations must relate to the nature, characteristics, quality, or geographic origin of either (or both) the parties' goods or services to be actionable. Because the plaintiff's amended complaint failed to link the defendant's use of the registration symbol to any of these items, the defendant's motion to dismiss was well-taken.¹⁴⁵²

Without extended analysis, the court reached a different conclusion with respect to the defendant's representation that the plaintiff's siding was "[s]ubject to damage caused by woodpeckers, termites and other pests that can harm wood." That representation, the court concluded, was "testable," although not literally false. *Id.* at 520 (alteration in original).

¹⁴⁴⁹ See *Bd. of Forensic Document Exam'rs, Inc. v. Am. Bar Ass'n*, 922 F.3d 827 (7th Cir. 2019).

¹⁴⁵⁰ *Id.* at 832.

¹⁴⁵¹ See *San Diego Cty. Credit Union v. Citizens Equity First Credit Union*, 360 F. Supp. 3d 1039 (S.D. Cal. 2019).

¹⁴⁵² *Id.* at 1054-55.

A wholly different basis for a motion to dismiss also met with success.¹⁴⁵³ The allegedly false statements in question appeared on labels of goods produced by a group of defendants styled as “Supplier Defendants.” In addition to targeting the Supplier Defendants, the plaintiff’s complaint named several retailers, referred to collectively as “Retailer Defendants,” that apparently had done nothing more than stock the Supplier Defendants’ goods. Summarizing the basis of the Retailer Defendants’ motion to dismiss, the court remarked that “[the] Retail Defendants deny any such involvement in making [the Supplier Defendants’] labels and state, quite persuasively, that it is implausible that independent retailers who merely sell the products had any influence on product labeling.”¹⁴⁵⁴ When the plaintiff failed to contest that proposition, the court dismissed its false advertising cause of action, in the process rejecting the plaintiff’s argument that “its claim should survive because simply putting a product that is falsely labeled into commerce is sufficient to [support] a false advertising claim.”¹⁴⁵⁵

A final noteworthy opinion rejecting a claim of false advertising for failure to state a claim came from a Pennsylvania appellate court in an appeal by a medical center.¹⁴⁵⁶ Having extended staff privileges to a plastic surgeon allegedly known as “The Vagician” based on his skills south of the suspenders and in the field of breast augmentation, the plaintiff was distressed to learn the surgeon had contracted with the defendants to develop a reality show entitled *Drastic Plastic*. In particular, it objected to an early video developed to market the proposed show in which participants identified themselves as the surgeon’s West Virginia-based employees and patients and that allegedly presented the patients as “crazy” rubes “willing to waste money on unnecessary plastic surgery.”¹⁴⁵⁷ The trial court hearing the case sustained a demurrer to the plaintiff’s complaint, and the court of appeals affirmed. As the latter explained, “[the plaintiff] has not alleged there are any false statements about the medical services offered at [the plaintiff’s facility] in the Video. Accordingly, we affirm the trial court’s order as to [the plaintiff’s] claim under the Lanham Act.”¹⁴⁵⁸

Despite these pro-defendant holdings, a Utah federal district court refused to disturb a jury’s finding that the word “local” was an actionable statement of fact.¹⁴⁵⁹ That word appeared in a tagline

¹⁴⁵³ See *Outlaw Lab., LP v. Shenoor Enter.*, 371 F. Supp. 3d 355 (N.D. Tex. 2019).

¹⁴⁵⁴ *Id.* at 363.

¹⁴⁵⁵ *Id.*

¹⁴⁵⁶ See *Weirton Med. Ctr. v. Introublezone, Inc.*, 193 A.3d 967 (Pa. Sup. Ct. 2018).

¹⁴⁵⁷ *Id.* at 970.

¹⁴⁵⁸ *Id.* at 974.

¹⁴⁵⁹ See *Bimbo Bakeries USA, Inc. v. Sycamore*, 372 F. Supp. 3d 1291 (D. Utah 2019), *appeal docketed*, No. 19-4040 (10th Cir. Mar. 22, 2019).

used by the defendants, namely, “Fresh. Local. Quality.” The plaintiff alleged that use of the word suggested the defendants’ baked goods were produced in Utah when, in fact, they came from outside that state. As the court summarized their position in post-trial motion practice, the defendants sought to escape liability by arguing that ‘local’ is not a specific geographic location that can be verified objectively as either true or false.”¹⁴⁶⁰ They did so unsuccessfully, however, in light of the court’s holding that “a term does not need to designate a specific geographic origin to be actionable,”¹⁴⁶¹ a conclusion that rested in part on expert testimony that “local” meant at least “in state.”¹⁴⁶²

Other opinions declined to dispose of plaintiffs’ claims as a matter of law. For example, at least one group of plaintiffs escaped a motion to dismiss based on the theory that the defendant’s representations about the plaintiffs’ products were nonactionable statements of opinion.¹⁴⁶³ The defendant manufactured single-server coffee brewers and disposable cartridges used by the brewers, while the plaintiffs sold cartridges they claimed were compatible with the defendant’s brewers. Disagreeing with that characterization, the defendant advised the trade that only its own cartridges were compatible with its brewers; moreover, it allegedly also “through its websites, social media, and customer service representatives, disseminated false and misleading messaging regarding quality and safety issues with respect to [the plaintiff’s goods].”¹⁴⁶⁴

The defendant argued the plaintiffs’ false advertising-based challenge to its conduct failed to state a claim because the representations in question were nonactionable subjective statements of quality, performance, and safety. The court rejected that theory, noting that the plaintiffs’ complaints contained “numerous purported misrepresentations made in the course of advertising through a variety of traditional and social media advertising platforms,” as well as the allegation that consumers were misled about the necessity of using cartridges produced by the defendant in the defendant’s machines.¹⁴⁶⁵ According to the court, “[s]uch statements involve more than the mere use of qualifiers and cross the line into statements of direction or fact.”¹⁴⁶⁶ “In any event,” the court concluded, “any challenge based on the actual truth or

¹⁴⁶⁰ *Id.* at 1301.

¹⁴⁶¹ *Id.*

¹⁴⁶² *Id.* at 1301 n.55.

¹⁴⁶³ *See In re Keurig Green Mountain Single-Serve Coffee Antitrust Litig.*, 383 F. Supp. 3d 187 (S.D.N.Y. 2019).

¹⁴⁶⁴ *Id.* at 215.

¹⁴⁶⁵ *Id.* at 247.

¹⁴⁶⁶ *Id.*

falsity of the statements is not appropriately raised on a motion to dismiss.”¹⁴⁶⁷

Another motion to dismiss also failed after the court hearing it greatly blurred the Lanham Act’s causes of action for false advertising, on the one hand, and trademark and trade dress infringement, on the other.¹⁴⁶⁸ That occurred in the course of the liquidation of a taxicab company in which the bankruptcy trustee objected to the former managers of the company using a name and trade dress similar to those of the company. The former managers challenged the trustee’s false advertising cause of action for failure to state a claim, but the court found it sufficiently pleaded. As it explained, “the Trustee has alleged that . . . Defendants’ use of the color yellow, the design mark, and a similar name (Yellow Cab *Association* rather than Yellow Cab *Affiliation*) constitutes a false statement of fact implying that [one company] is affiliated with [the other]”¹⁴⁶⁹

Finally, a defense motion for summary judgment failed to convince a Florida federal district court that allegedly false statements by an attorney and his law firm were merely statements of opinion about the timeshare industry generally and the plaintiffs, a group of timeshare developers, in particular.¹⁴⁷⁰ The defendants argued they had qualified the challenged statements in ways rendering them actionable. The court agreed that might be true with respect to certain of the statements, but it disagreed that the defendants therefore deserved to prevail as a matter of law:

Although Defendants use equivocal phrases about timeshare developers’ potential unlawful conduct such as “chances are” and “may well be,” the Subject Advertisements also contain more direct, unequivocal statements about the same conduct The Subject Advertisements also directly challenge the legality of [Plaintiffs’] conduct, stating “By what legal authority can they do anything at all to control the management of the resort?”; “maybe they can cite some legal authority for that one”; and “No one said that any of this is necessarily lawful.” Some of these then end by inviting readers to call to discuss legal options. So while there may be individual statements or phrases in the Subject Advertisements that are undeniably opinions or partly true, the Court finds that each Subject Advertisement also conveys a factual basis, not solely opinion.¹⁴⁷¹

¹⁴⁶⁷ *Id.* (citation omitted).

¹⁴⁶⁸ *See* Desmond v. Taxi Affiliation Servs. LLC, 344 F. Supp. 3d 915 (N.D. Ill. 2018).

¹⁴⁶⁹ *Id.* at 930.

¹⁴⁷⁰ *See* Diamond Resorts Int’l, Inc. v. Aaronson, 371 F. Supp. 3d 1088 (M.D. Fla. 2019).

¹⁴⁷¹ *Id.* at 1104-05 (citations omitted).

The court then identified a number of additional considerations warranting the denial of the defendants' motion, namely: (1) "these advertisements are authored by a lawyer and appear on his law firm's website—a firm dedicated to timeshare cancellation";¹⁴⁷² (2) "[t]hey also directly accuse [the plaintiffs] and other timeshare developers of committing fraud, perpetuating conflicts of interests, breaching fiduciary duties, and other unlawful activity";¹⁴⁷³ (3) "Defendants represent themselves as 'experienced, competent counsel' and contend there are 'obvious' and 'easy to prove' claims that can be raised against timeshare developers";¹⁴⁷⁴ and (4) "the Subject Advertisements call on readers to contact Defendants immediately for a free consultation, with an assurance that their legal problems are not insurmountable."¹⁴⁷⁵ "Against this backdrop," the court concluded, it could not find that "no genuine issues of material fact exist on the false and misleading nature of the Subject Advertisements."¹⁴⁷⁶

(B) Actionable Commercial Advertising and Promotion

(1) Opinions Finding Actionable Commercial Advertising and Promotion

In contrast to some past years, reported opinions addressing the issue of whether defendants' alleged misrepresentations rose to the level of actionable commercial advertising were few and far between. One opinion undertaking the inquiry did so only after a trial in which the jury found the defendants liable under the plaintiffs' Section 43(a) cause of action.¹⁴⁷⁷ The defendants argued in post-trial motions that certain of the challenged statements did not qualify as commercial advertising and promotion, but the fact that the statements were contained in larger documents that did so qualify sank the defendants' motions on the issue. Those larger documents were a webpage and a letter sent to "hundreds of doctors around the United States,"¹⁴⁷⁸ which led the court to sustain the jury's verdict with the explanation that "there is no dispute that

¹⁴⁷² *Id.* at 1105.

¹⁴⁷³ *Id.*

¹⁴⁷⁴ *Id.*

¹⁴⁷⁵ *Id.*

¹⁴⁷⁶ *Id.*

¹⁴⁷⁷ *See* *De Simone v. VSL Pharm., Inc.*, 395 F. Supp. 3d 617 (D. Md. 2019), *appeal docketed sub nom* *De Simone v. Alfasiigma USA, Inc.*, No. 19-1731 (4th Cir. July 12, 2019), *and appeal docketed sub nom* *De Simone v. Leadiant Biosciences, Inc.*, No. 19-1762 (4th Cir. July 22, 2019).

¹⁴⁷⁸ *Id.* at 624.

both the . . . Webpage and the . . . Letter were disseminated in a manner sufficient to constitute commercial advertising”¹⁴⁷⁹

(2) Opinions Declining to Find Actionable Commercial Advertising and Promotion

Some defendants successfully challenged the adequacy of allegations of commercial advertising and promotion against them at the pleadings stage.¹⁴⁸⁰ For example, an opinion from a California federal district court addressing a motion to dismiss allegations of false advertising against a group of pharmaceutical manufacturers and a pricing list company adopted the following test for determining identifying actionable commercial and promotion:

For purposes of a false advertising claim, statements constitute commercial advertising if they are: “(1) commercial speech; (2) by a defendant who is in commercial competition with plaintiff; (3) for the purpose of influencing consumers to buy defendant’s goods or services. While the representations need not be made in a ‘classic advertising campaign,’ but may consist instead of more informal types of ‘promotion,’ the representations (4) must be disseminated sufficiently to the relevant purchasing public to constitute ‘advertising’ or ‘promotion’ within that industry.”¹⁴⁸¹

This restatement of the law was occasioned by claims by one of the defendants that its product was “grandfathered” under Food and Drug Administration (“FDA”) regulations or that it otherwise enjoyed approval under a “preliminary new drug application.”¹⁴⁸² Whatever the truth or accuracy of those representations, the plaintiff’s complaint failed to allege the defendant had made them to actual purchasers of the product; instead, it averred the defendant had included the representations in either investor earnings calls or securities filings. Granting the defendant’s motion to dismiss, the court acknowledged that “[t]o be sure, statements contained in SEC filings, such as the 10-K or 10-Q forms cited by [the plaintiff], could form the basis of a Lanham Act false advertising claim.”¹⁴⁸³ “But in order to be actionable,” it continued,

¹⁴⁷⁹ *Id.*

¹⁴⁸⁰ *See, e.g., Drone Racing League, Inc. v. DR1, LLC*, 129 U.S.P.Q.2d 1083, 1089 (S.D.N.Y. 2018) (dismissing for failure to state a claim cause of action for false advertising grounded in alleged misstatements in slide presentation aimed at securing sponsors for drone racing league, rather than at the promotion of goods produced by defendant).

¹⁴⁸¹ *Genus Lifesciences Inc. v. Lannett Co.*, 378 F. Supp. 3d 823, 834 (N.D. Cal.) (quoting *Rice v. Fox Broad. Co.*, 330 F.3d 1170, 1181 (9th Cir. 2003), *reconsideration denied*, No. 18-cv-07603-WHO, 2019 WL 4168958 (N.D. Cal. Sept. 3, 2019)).

¹⁴⁸² *Id.*

¹⁴⁸³ *Id.* at 835.

“the statements must be accompanied by specific allegations that they were made for the purpose of influencing the customers of cocaine hydrochloride solutions to buy [the product], or were disseminated sufficiently to the relevant purchasing public (pharmacists, hospitals, and doctors) to constitute ‘advertising’ or ‘promotion’ within the pharmaceutical industry.”¹⁴⁸⁴ Having concluded that the plaintiff’s averments failed to satisfy that standard, the court therefore disposed of the plaintiff’s challenge to the defendant’s alleged advertising at the pleadings stage of the case.¹⁴⁸⁵

Another reported opinion granting a motion to dismiss on the same principle issued from a Pennsylvania federal district court.¹⁴⁸⁶ The defendants operated consumer-review websites on which appeared commentary critical of the plaintiff’s weight-loss program. In holding the reviews nonactionable, the court evaluated whether they rose to the level of actionable commercial advertising and promotion using a three-part test, namely, “whether the speech (i) is an advertisement, (ii) refers to a specific product or service, and (iii) whether the speaker has an economic motivation for the speech.”¹⁴⁸⁷ After reaching a threshold finding that “the heart of Plaintiff’s grievance is with the content of the reviews,”¹⁴⁸⁸ the court determined the reviews were nonactionable. It did so despite the plaintiff’s argument that “Defendants’ reviews are . . . commercial speech because they are meant to affect the readers’ purchasing decisions—that is, to encourage readers to buy certain products, steer clear of others, and click on surrounding advertisements and related links, with some of those ‘clicks’ financially benefitting the Defendants.”¹⁴⁸⁹ Addressing that contention, the court acknowledged that “Plaintiff is correct that liability can arise under the Lanham Act if websites purporting to offer reviews are in reality stealth operations intended to disparage a competitor’s product while posing as a neutral third party.”¹⁴⁹⁰ The defendants’ operations, however, did not fall within that category.

¹⁴⁸⁴ *Id.* at 835-36.

¹⁴⁸⁵ *Id.* at 836.

¹⁴⁸⁶ See *GOLO, LLC v. HighYa, LLC*, 310 F. Supp. 3d 499 (E.D. Pa. 2018).

¹⁴⁸⁷ *Id.* at 504.

¹⁴⁸⁸ *Id.* at 505.

¹⁴⁸⁹ *Id.*

¹⁴⁹⁰ *Id.*

(3) Opinions Deferring Resolution of the Actionable-Commercial-Advertising-and-Promotion Inquiry

Faced with a claim it had falsely advertised that the plaintiffs' goods were incompatible with its own, one defendant sought the dismissal of the plaintiffs' cause of action on the theory that the disputed statements did not rise to the level of commercial advertising and promotion.¹⁴⁹¹ In denying the defendant's motion to dismiss, the New York federal district court hearing the case invoked the Second Circuit's tripartite test on the issue: "[T]he speech is covered if it is (1) commercial speech; (2) for the purpose of influencing consumers to buy defendant's goods or services; and, (3) 'although representations less formal than those made as part of a classic advertising campaign may suffice, they must be disseminated sufficiently to the relevant purchasing public.'"¹⁴⁹² Although not applying those factors seriatim, the court found adequate the plaintiffs' averments that "certain of [the defendant's] statements were made to consumers by using Facebook and Amazon.com" and that "these statements were all made to consumers who had already purchased the brewer, [and] they were made in the open. In other words, they were available to be viewed by not only consumers who owned brewers but also by consumers who were contemplating purchasing brewers."¹⁴⁹³ "This type of communication," the court held, "is materially different from a one-on-one communication between a manufacturer and a consumer inquiring about the product owned by the consumer. Therefore, such statements are appropriately viewed as being made for consumption by a wider audience for the purpose of influencing other consumers to buy defendant's goods or services."¹⁴⁹⁴ The plaintiffs' complaint therefore made it past the pleadings stage.

A second opinion denying a motion to dismiss came in a suit by the owner of the copyright covering a personal memoir against several media and entertainment companies.¹⁴⁹⁵ The gravamen of the plaintiff's cause of action for false advertising was that the defendants had promoted an episode of a television series by promising viewers the "true," or "real," story behind the memoir and a film based on it. The court applied a three-part test to determine that the plaintiff's complaint sufficiently averred the existence of actionable commercial advertising or promotion contemplating the

¹⁴⁹¹ See *In re Keurig Green Mountain Single-Serve Coffee Antitrust Litig.*, 383 F. Supp. 3d 187 (S.D.N.Y. 2019).

¹⁴⁹² *Id.* at 248 (quoting *Fashion Boutique of Short Hills, Inc. v. Fendi USA, Inc.*, 314 F.3d 48, 56 (2d Cir. 2002)).

¹⁴⁹³ *Id.*

¹⁴⁹⁴ *Id.*

¹⁴⁹⁵ See *Incarcerated Entm't, LLC v. CNBC LLC*, 331 F. Supp. 3d 352 (D. Del. 2018).

following inquiries: (1) “is the speech an advertisement; (2) does the speech refer to a specific product or service; and (3) does the speaker have an economic motivation for the speech.”¹⁴⁹⁶ “Satisfaction of three characteristics,” it explained, provides ‘strong support’ for concluding the speech is commercial.”¹⁴⁹⁷

Applying that test, the court credited a number of considerations favoring a denial of the defendants’ motion to dismiss. For one thing, the defendants’ briefing itself referred to the disputed statements as an advertisement. That possibly ill-advised choice of wording was not the defendants’ only problem, however, in light of the court’s conclusion under the second factor that “[t]he promotional statement refers to a specific product, the [defendants’] television show.”¹⁴⁹⁸ Finally, with respect to the third factor, “[the defendants] created the promotional statement to convince viewers to watch [their program]. It is hard to imagine a purpose other than economic motivation to promote to potential viewers they can learn the “true” story behind [the memoir and a film based on it] by watching”¹⁴⁹⁹

(C) *Falsity*

Courts generally agreed there were two ways in which to demonstrate falsity. In the words of the Eleventh Circuit:

To establish the “false or misleading statement” element of the claim, the plaintiff must prove that “the statements at issue were either ‘(1) commercial claims that are literally false as a factual matter,’ or ‘(2) claims that may be literally true or ambiguous but which implicitly convey a false impression, are misleading in context, or are likely to deceive consumers.’”¹⁵⁰⁰

¹⁴⁹⁶ *Id.* at 359 (quoting *U.S. Healthcare, Inc. v. Blue Cross of Greater Phila.*, 898 F.2d 914, 933 (3d Cir. 1990)).

¹⁴⁹⁷ *Id.* (quoting *U.S. Healthcare*, 898 F.2d at 933).

¹⁴⁹⁸ *Id.* at 361.

¹⁴⁹⁹ *Id.*

¹⁵⁰⁰ *Hi-Tech Pharm., Inc. v. HBS Int’l Corp.*, 910 F.3d 1186, 1196 (11th Cir. 2018) (quoting *Hickson Corp. v. N. Crossarm Co.*, 357 F.3d 1256, 1261 (11th Cir. 2004)); *accord* *De Simone v. VSL Pharm., Inc.*, 395 F. Supp. 3d 617, 623 (D. Md. 2019), *appeal docketed sub nom* *De Simone v. Alfasigma USA, Inc.*, No. 19-1731 (4th Cir. July 12, 2019), *and appeal docketed sub nom* *De Simone v. Leadiant Biosciences, Inc.*, No. 19-1762 (4th Cir. July 22, 2019); *MillerCoors, LLC v. Anheuser-Busch Cos.*, 385 F. Supp. 3d 730, 744 (W.D. Wis.), *modified*, No. 19-cv-218-wmc, 2019 WL 4187489 (W.D. Wis. Sept. 4, 2019), *and modified*, No. 19-cv-218-wmc, 2019 WL 4247725 (W.D. Wis. Sept. 6, 2019), *remanded on other grounds*, 940 F.3d 922 (7th Cir. 2019); *Genus Lifesciences Inc. v. Lannett Co.*, 378 F. Supp. 3d 823, 833 (N.D. Cal.), *reconsideration denied*, No. 18-cv-07603-WHO, 2019 WL 4168958 (N.D. Cal. Sept. 3, 2019); *Bimbo Bakeries USA, Inc. v. Sycamore*, 372 F. Supp. 3d 1291, 1300 (D. Utah 2019), *appeal docketed*, No. 19-4040 (10th Cir. Mar. 22, 2019); *Diamond Resorts Int’l, Inc. v. Aaronson*, 371 F. Supp. 3d 1088, 1103 (M.D. Fla. 2019); *Am. Fireglass v. Moderustic, Inc.*, 365 F. Supp. 3d 1062, 1082 (S.D. Cal.),

Both theories of falsity came into play over the past year.

(1) Opinions Finding Falsity

The past year was unusual for the number of findings of falsity on plaintiffs' motions for summary judgment. One noteworthy opinion reaching a finding of literal falsity did so as a matter of law on undisputed facts easily justifying that conclusion.¹⁵⁰¹ Years before the parties' dispute, the plaintiff, a provider of construction equipment and engineering services, acquired a subsidiary with registered marks. Having learned of the plaintiff's dissolution of the subsidiary and the lapsing of several registrations, the defendants secured two domain name registrations incorporating one of the marks in question and then posted claims that they were responsible for past projects on which the plaintiff and the subsidiary actually worked. The court summarized the brazen nature of the defendants' misrepresentations:

[A]ll of the Defendants have made numerous false statements claiming [the subsidiary's] historical accomplishments as their own. Defendants collectively represent . . . that they completed projects including the Hoover Dam, San Francisco-Oakland Bay Bridge, Trans-Alaska Pipeline, NASA's Space Kennedy Center, Olmsted Dam Construction, Addison Airport, Miami-Dade Expressway Authority, and Snoqualmie Pass. These are just a few examples of the numerous projects Defendants have claimed, that either the [subsidiary] completed prior to its acquisition by [Plaintiff] or that are current . . . projects [of Plaintiff]. These statements are literally false, and Defendants have not put forth evidence to the contrary.¹⁵⁰²

That was not the only opinion to reach a finding of literal falsity as a matter of law, for one from a California federal district court reached two such findings.¹⁵⁰³ The parties before that court competed in the market for glucomannan dietary weight-loss supplements, and the gravamen of the counterclaim plaintiff's complaint was that the counterclaim defendant had

reconsideration denied, No. 15-CV-2866 JLS (BGS), 2019 WL 4918042 (S.D. Cal. Oct. 4, 2019), *appeal docketed*, No. 20-1294 (Fed. Cir. Dec. 30, 2019); San Diego Cty. Credit Union v. Citizens Equity First Credit Union, 360 F. Supp. 3d 1039, 1052 (S.D. Cal. 2019); *Incarcerated Entm't*, 331 F. Supp. 3d at 362.

¹⁵⁰¹ See *AECOM Energy & Constr., Inc. v. Ripley*, 348 F. Supp. 3d 1038 (C.D. Cal. 2018), *reconsideration denied*, No. CV 17-5398-RSWL-SSx, 2019 WL 2610953 (C.D. Cal. Apr. 24, 2019), *appeal docketed*, No. 19-55588 (9th Cir. May 23, 2019).

¹⁵⁰² *Id.* at 1056 (citations omitted).

¹⁵⁰³ See *Obesity Research Inst., LLC v. Fiber Research Int'l, LLC*, 310 F. Supp. 3d 1089 (S.D. Cal.), *motion to certify denied*, No. 15-cv-00595-BAS-MDD, 2018 WL 1791611 (S.D. Cal. Apr. 16, 2018).

mischaracterized a study of the efficacy of glucomannan as a weight-loss tool. One claim made by the counterclaim defendant was that the survey had been conducted under the auspices of a “major university,” but all the counterclaim defendant could muster in support of that representation was that two named reviewers of the study were “affiliated with two major universities—Georgetown University and the University of Texas” and that the study’s design had been approved by an “institutional review board” of Texas Women’s University.¹⁵⁰⁴ “Without assessing whether Texas Women’s University would qualify as a ‘major university,’”¹⁵⁰⁵ the court held, neither the approval of that school’s review board nor the attenuated participation of the two reviewers created a factual dispute concerning the literal falsity of the counterclaim defendant’s representations on this subject.¹⁵⁰⁶

The court then reached the same conclusion with respect to the counterclaim defendant’s representation that participants in the study were “asked not to change their lifestyle” and “asked not to change their diet and exercise.”¹⁵⁰⁷ In fact, the study itself recited that “[n]o instructions were provided to study participants with regard to diet and exercise; participants were free to follow, or not to follow, any diet and/or exercise program of their own choosing”¹⁵⁰⁸ and that “[s]ince no diet/exercise recommendations were provided, participants were free to follow any diet/exercise plan of their own choosing.”¹⁵⁰⁹ The court therefore held the counterclaim defendant liable for false advertising as a matter of law, explaining that “participants could change their diet or add an exercise routine if they wanted, which could have affected the weight they lost. [The counterclaim defendant’s] statement implies the opposite.”¹⁵¹⁰

A different California federal district court similarly reached a finding of liability for false advertising by granting a motion for summary judgment, albeit without expressly labeling the challenged statements either literally false or literally true but misleading in context.¹⁵¹¹ The lead plaintiff bringing that motion was a national farmers’ association, while the defendants were a former chapter of the plaintiff and the individual serving as the

¹⁵⁰⁴ *Id.* at 1119-20.

¹⁵⁰⁵ *Id.* at 1120.

¹⁵⁰⁶ *Id.* at 1121.

¹⁵⁰⁷ *Id.*

¹⁵⁰⁸ *Id.*

¹⁵⁰⁹ *Id.*

¹⁵¹⁰ *Id.* at 1122.

¹⁵¹¹ See *Nat’l Grange of the Order of Patrons of Husbandry v. Cal. Guild*, 334 F. Supp. 3d 1057 (E.D. Cal. 2018), *reconsideration denied sub nom. Nat’l Grange v. Cal. Guild*, No. 2:16-cv-0201 WBS DB, 2018 WL 5270563 (E.D. Cal. Oct. 22, 2018), *appeal docketed*, No. 18-16671 (9th Cir. Sept. 5, 2018).

former chapter's leader. The court's discussion of the defendants' allegedly misleading statements was rather terse and preceded by the caveat that "[t]he court need not analyze every comment defendants have made . . . in order to conclude that false and misleading statements have been made."¹⁵¹² Nevertheless, it provided "just a few examples," namely: (1) "defendants' membership brochures state that '[the lead defendant] is a grass roots organization that began in 1870,' thereby falsely taking credit for plaintiffs' organization and not clarifying that defendants' organization did not in fact begin until 2013"; and (2) "defendants' former website contained links to historical publications of the [lead plaintiff's new affiliate] as though they were publications of [the lead] defendant . . ."¹⁵¹³ Summary judgment of liability therefore held.

Still another California federal district court reached a finding of literal falsity based on a summary judgment record in a case brought by a manufacturer of pharmaceutical products against a drug compounder and marketer of the compounder's products.¹⁵¹⁴ The defendants' business model rested on an FDA policy allowing facilities such as the compounder's to use bulk drug substances if: (1) drugs produced by them appeared on the FDA's drug shortage list; or (2) the FDA had found a clinical need for them to produce drugs using a particular bulk drug substance. The defendants marketed the compounder's drugs as "FDA approved" and having been produced in an "FDA accredited" facility, but the court found that promotional strategy literally false for two reasons. The first was that certain of the bulk drugs used in the facility in question did not satisfy the two criteria listed above. The second was that, even if those criteria had been satisfied, that would not have rendered the drugs produced by the facility FDA-approved; instead, there was no material dispute that the agency registered and inspected similar facilities but did not approve or accredit them.¹⁵¹⁵

Of course, not every case is a candidate for a meritorious motion for summary judgment, and, as always, some findings of falsity followed trials on the issue. For example, one Utah federal district court declined to overturn as clearly erroneous a jury's finding that the use of the word "local" to describe goods produced outside that state by a commercial bakery and its principal were false in context.¹⁵¹⁶ Having concluded the word was not mere puffery (and

¹⁵¹² *Id.* at 1067.

¹⁵¹³ *Id.*

¹⁵¹⁴ *See Allergan USA, Inc. v. Prescribers Choice, Inc.*, 364 F. Supp. 3d 1089 (C.D. Cal. 2019).

¹⁵¹⁵ *Id.* at 1112.

¹⁵¹⁶ *See Bimbo Bakeries USA, Inc. v. Sycamore*, 372 F. Supp. 3d 1291 (D. Utah 2019), *appeal docketed*, No. 19-4040 (10th Cir. Mar. 22, 2019).

therefore actionable), the court denied the defendants' post-trial attacks on the jury's verdict with the following observation:

Here, "local" is a geographically descriptive term, and [the plaintiff] presented evidence that [the defendants] used the term in a deceptive manner concerning the origin of [their] bread product[s]—namely, to suggest that its bread products were particularly fresh and of high quality because they were baked within the geographic vicinity of where they were sold.¹⁵¹⁷

"Therefore," the court concluded, "the jury's verdict was sufficiently supported by the evidence and not legal error."¹⁵¹⁸

In a case in which another jury verdict of liability vindicated a claim of literal falsity, the plaintiffs had once licensed the defendants to use a propriety mix of eight strains of bacteria in the manufacture of a probiotic product.¹⁵¹⁹ When that relationship ran its course, the defendants adopted their own mix but advertised that mix with representations it "maintain[ed] the original proprietary mix of eight strains of live bacteria"¹⁵²⁰ and that it was "the same quality product, containing the same genus and species of bacteria, in the same proportions that you have come to expect."¹⁵²¹ In support of their Section 43(a) cause of action, the plaintiffs proffered testimony from an expert witness, who opined he was "100%" certain the defendants' mix "had only seven strains of live bacteria, not eight, and was thus genetically different from" the earlier mix produced during the pendency of the license;¹⁵²² other experts retained by the plaintiffs testified to similar effect.¹⁵²³ The plaintiffs also relied on the admission of the president and CEO of the lead defendant that the scientists retained by the defendants to reverse engineer the earlier mix were "not able to give a precise indication of the percentage of each strain[]," or even an accurate range of those percentages, "but instead could only measure the amount of each strain with a margin of error of 30 percent."¹⁵²⁴ Although the defendants countered with expert testimony of their own to the effect that the defendants' mix indeed contained eight strains of bacteria, that witness did not opine that the ratios of strains in the

¹⁵¹⁷ *Id.* at 1301.

¹⁵¹⁸ *Id.*

¹⁵¹⁹ *See De Simone v. VSL Pharm., Inc.*, 395 F. Supp. 3d 617 (D. Md. 2019), *appeal docketed sub nom De Simone v. Alfasigma USA, Inc.*, No. 19-1731 (4th Cir. July 12, 2019), and *appeal docketed sub nom. De Simone v. Leadiant Biosciences, Inc.*, No. 19-1762 (4th Cir. July 22, 2019).

¹⁵²⁰ *Id.* at 624.

¹⁵²¹ *Id.*

¹⁵²² *Id.* at 625.

¹⁵²³ *Id.* at 627.

¹⁵²⁴ *Id.* at 625 (alteration in original).

two mixes were the same. The defendants attempted to parlay these differences in the experts' opinions into a finding that, as a matter of law, their advertising was not literally false, but the court declined to reach such a result. Instead, it concluded, "[i]n the absence of a concession [by the plaintiffs] that the statement is the subject of reasonable scientific debate, that question is properly decided by the jury."¹⁵²⁵ The jury therefore had been within its rights to find the defendants' advertising literally false, especially in light of "non-scientific evidence" supporting the verdict in the form of the defendants' own regulatory filings.¹⁵²⁶

Findings of falsity also occurred in a preliminary injunction opinion arising from a lawsuit by the producer of MILLER LIGHT and COORS LIGHT beer against that of BUD LIGHT.¹⁵²⁷ The subject of the plaintiff's motion was a series of nationwide advertisements by the defendant indicating the plaintiff brewed its beer using corn syrup; the same advertisements invariably advised viewers that the defendant brewed its beer without using that substance. Those advertisements included a television commercial featuring the following representations:

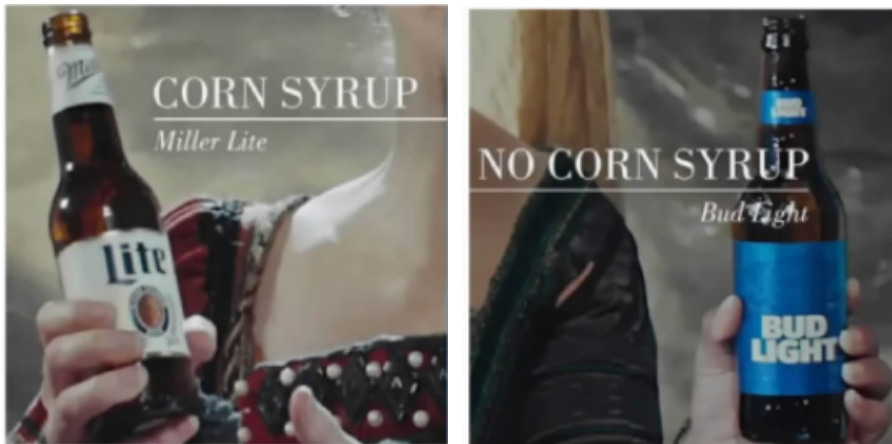

The defendant's advertising also characterized its beer as having "100% less corn syrup than Miller Lite or Coors Light," referred to

¹⁵²⁵ *Id.* at 626.

¹⁵²⁶ *Id.* at 627.

Although possibly unnecessary to the court's rejection of the defendants' attack on the jury's verdict, the court noted an additional basis for that verdict, namely, advertising by the defendants that misleadingly suggested the defendants' mix was produced "in the same facility" as it always had been. *Id.*

¹⁵²⁷ See *MillerCoors, LLC v. Anheuser-Busch Cos.*, 385 F. Supp. 3d 730 (W.D. Wis.), *modified*, No. 19-cv-218-wmc, 2019 WL 4187489 (W.D. Wis. Sept. 4, 2019), and *modified*, No. 19-cv-218-wmc, 2019 WL 4247725 (W.D. Wis. Sept. 6, 2019), *remanded on other grounds*, 940 F.3d 922 (7th Cir. 2019).

corn syrup as an “ingredient,” and represented that corn syrup was used to “save money” or was “less expensive.”¹⁵²⁸

The plaintiff did indeed use corn syrup as a sugar source in the nutrient substrate necessary for fermentation to occur, while the defendant used rice as its sugar source, and those undisputed facts precluded the plaintiff from establishing the literal falsity of the defendant’s advertising. The reality, however, was that neither sugar source was present in the final product sold by either party. This led the court to find that, although literally true, the “corn syrup”/“no corn syrup” advertisements nevertheless were actionable as misleading in context:

[T]hese advertisements—either in stating what is *not* in Bud Light or in stating what *is* in Miller Lite or Coors Light—cross the line from simply being susceptible to misunderstanding to being misleading, or, at minimum, the court finds that plaintiff is likely to succeed in making such a showing.”¹⁵²⁹

The court reached the same conclusion with respect to the defendant’s characterization of corn syrup as an “ingredient” in the statement, “[p]eople want to know what ingredients are in their beer,” finding that “plaintiff is likely to succeed in demonstrating that this language is misleading because it crosses the line to encourage a reasonable consumer to believe that corn syrup is actually contained in the final product.”¹⁵³⁰

A separate ingredient-based claim led to the same result, also on a motion for preliminary injunctive relief.¹⁵³¹ The claim at issue was the defendant’s representation that its drinkable yogurt contained “33% less sugar than the leading kids’ drinkable yogurt,”¹⁵³² meaning the plaintiff’s competitive product. Although it was not literally false in light of information found in two footnotes on the rear panel of the defendant’s packaging, the inaccessibility and confusing nature of the footnotes rendered the representation false and misleading in context.¹⁵³³ In particular, the footnotes suggested that, if consumers undertook a series of calculations based on the average sugar content of the products comprising the defendants’ entire line of yogurt, those calculations might indeed produce a figure of 33 percent less sugar. “Unfortunately for the consumer,”

¹⁵²⁸ *Id.* at 746.

¹⁵²⁹ *Id.* at 751.

¹⁵³⁰ *Id.* at 752-53.

¹⁵³¹ *See* Danone, US, LLC v. Chobani, LLC, 362 F. Supp. 3d 109 (S.D.N.Y. 2019).

¹⁵³² *Id.* at 113.

¹⁵³³ *Id.* at 114.

the court concluded, “substantiating [the defendant’s] claim is anything but uncomplicated.”¹⁵³⁴

(2) Opinions Declining to Find Falsity

Affirming a district court’s refusal to enter a preliminary injunction, the Sixth Circuit tackled an allegation of literally false advertising in the residential siding business.¹⁵³⁵ According to the plaintiff, the defendant’s representation that the plaintiff’s “engineered wood siding” was “[s]ubject to damage caused by woodpeckers, termites and other pests that can harm wood” was literally false.¹⁵³⁶ The plaintiff supported that theory with evidence that any termites “grazing” on its siding would meet their demise from the zinc borate with which the siding was impregnated. The problem with the plaintiff’s case, the court concluded, was that “termites must still ingest small amounts of . . . the treated wood before the zinc borate poisons the termites.”¹⁵³⁷ Thus, although it might be true that “grazing causes no structural or obvious aesthetic damage,” the plaintiff’s own experts had acknowledged that grazing caused at least some damage.¹⁵³⁸ Having failed to demonstrate that the defendant’s use of damage was an ambiguous reference to *structural* damage, the plaintiff had failed to carry its burden of demonstrating literal falsity.¹⁵³⁹

Two California federal district courts rejected claims of falsity as a matter of law in cases involving allegedly inaccurate representations of intellectual property rights. The first did so on a motion to dismiss for failure to state a claim.¹⁵⁴⁰ According to the plaintiff in that dispute, the defendant had falsely used the ® symbol in connection with a mark covered by a fraudulently procured registration. Because it was apparent on the face of the plaintiff’s amended complaint that the mark was, in fact, registered, that status precluded a challenge to the defendant’s use of the symbol in conjunction with the mark.¹⁵⁴¹

In the second case, an allegation of falsity in a dispute between manufacturers of tempered glass fragments for use in fire pits also

¹⁵³⁴ *Id.*

¹⁵³⁵ *See* La.-Pac. Corp. v. James Hardie Bldg. Prods., Inc., 928 F.3d 514 (6th Cir. 2019).

¹⁵³⁶ *Id.* at 519 (alteration in original).

¹⁵³⁷ *Id.*

¹⁵³⁸ *Id.*

¹⁵³⁹ *Id.* at 510-20.

¹⁵⁴⁰ *See* San Diego Cty. Credit Union v. Citizens Equity First Credit Union, 360 F. Supp. 3d 1039 (S.D. Cal. 2019).

¹⁵⁴¹ *Id.* at 1054.

fell short.¹⁵⁴² According to the plaintiff, the defendant had violated Section 43(a) and California law alike by sending letters to the plaintiff and the trade announcing the defendant's ownership of two utility patents, one of which, the letter acknowledged, was subject to a pending inter partes review. Although the IPR proceeding resulted in the invalidation of that patent, and although the court invalidated the other as obvious, those developments did not render the defendant's assertion of its then-extant patent rights literally true but misleading in context. Based on the summary judgment record, the court found that "no reasonable jury could find these statements to mislead, confuse, or deceive the consuming public when considered in their overall context."¹⁵⁴³ It explained that "[t]he letter clearly indicates that [one patent] is in reconsideration. More importantly, the [other patent] had been issued at the time the letters were sent, giving Defendant the right to enforce its legal rights as the Patent holder, regardless of the [first patent's] status."¹⁵⁴⁴

Another California federal district court also granted a defense motion for summary judgment in a challenge to statements by the counterclaim defendant concerning its dietary weight-loss supplements.¹⁵⁴⁵ The statements in question were "[t]ake pure Glucomannan from the finest Konjac Plants and see results" and "[the counterclaim defendant's supplement] is made with 100% pure Glucomannan, which comes from the root of the Konjac plant."¹⁵⁴⁶ Because the counterclaim defendant's supplement contain ingredients other than glucomannan, and because the supplement therefore was not "pure glucomannan," the counterclaim plaintiff argued those representations were literally false. That argument failed as a matter of law: "The Court finds that no reasonable juror could find that [the counterclaim defendant] was advertising that [its supplement] was entirely made with glucomannan, and that its 'pure glucomannan' statements are not false. Thus, the Court grants [the counterclaim defendants'] request for summary judgment"¹⁵⁴⁷

An allegation that a counterclaim defendant falsely represented the geographic origin of its footwear similarly failed as a matter of

¹⁵⁴² See *Am. Fireglass v. Moderustic, Inc.*, 365 F. Supp. 3d 1062 (S.D. Cal.), *reconsideration denied*, No. 15-CV-2866 JLS (BGS), 2019 WL 4918042 (S.D. Cal. Oct. 4, 2019), *appeal docketed*, No. 20-1294 (Fed. Cir. Dec. 30, 2019).

¹⁵⁴³ *Id.* at 1084.

¹⁵⁴⁴ *Id.*

¹⁵⁴⁵ See *Obesity Research Inst., LLC v. Fiber Research Int'l, LLC*, 310 F. Supp. 3d 1089 (S.D. Cal.), *motion to certify denied*, No. 15-cv-00595-BAS-MDD, 2018 WL 1791611 (S.D. Cal. Apr. 16, 2018).

¹⁵⁴⁶ *Id.* at 1123.

¹⁵⁴⁷ *Id.*

law.¹⁵⁴⁸ The counterclaim defendant originally sourced most of its goods from Australia, and consistent with that heritage, it affixed the legend UGG AUSTRALIA to its packaging. As it increasingly outsourced its manufacturing to countries other than Australia, however, the counterclaim defendant “rebranded from UGG AUSTRALIA to UGG” and labelled “the inside of each pair of [its] boots with the country of manufacture.”¹⁵⁴⁹ Noting that, “[w]hen determining whether a statement is deceptive or misleading, a court considers the statement in context, viewing the product as a whole,”¹⁵⁵⁰ the court rejected the counterclaim plaintiffs’ claims of falsity. As it read the summary judgment record, “[t]he UGG Australia label does not state that the boots were made in Australia. And because every pair of boots with that label also contains a more specific country of origin label, no reasonable juror could conclude that [the counterclaim defendant] deceptively marketed its boots as being made in Australia.”¹⁵⁵¹

The same opinion rejected another allegation of false advertising by the counterclaim plaintiffs, once again as a matter of law. That allegation targeted a search function on the counterclaim defendant’s website that allowed consumers to look up online retailers to confirm whether they were authorized to sell the counterclaim defendant’s goods; when a retailer did not turn up in the search results, the site reported that “[the searched term] isn’t known to our database and cannot be verified as an authorized retailer. This may be a site that deals in counterfeit products.”¹⁵⁵² Independent of that message, another online page maintained by the counterclaim defendant advised readers that “[s]ome Australian companies . . . circulate misinformation regarding the UGG mark.”¹⁵⁵³ But nowhere did the counterclaim defendant expressly refer to the counterclaim plaintiffs, and the absence of any such references, coupled with the nongenericness of the UGG mark, rendered the counterclaim plaintiffs’ allegations of falsity devoid of merit as a matter of law.¹⁵⁵⁴

Finally, a Wisconsin federal district court weighing a preliminary injunction motion rejected certain challenges to nationwide advertising placed by the producer of BUD LIGHT beer suggesting in various ways that the plaintiff’s MILLER LITE and COORS LIGHT beers “use[d],” or were “made with” or “brewed

¹⁵⁴⁸ See *Deckers Outdoor Corp. v. Australian Leather Pty. Ltd.*, 340 F. Supp. 3d 706 (N.D. Ill. 2018).

¹⁵⁴⁹ *Id.* at 719.

¹⁵⁵⁰ *Id.*

¹⁵⁵¹ *Id.*

¹⁵⁵² *Id.*

¹⁵⁵³ *Id.* (first alteration in original).

¹⁵⁵⁴ *Id.*

with” corn syrup.¹⁵⁵⁵ There was no dispute the plaintiff used corn syrup as part of the nutrient substrate that sustained its yeast cultures, although there also was no evidence that any corn syrup remained in the final products the plaintiff sold in the marketplace. The court found the first of these considerations more compelling than the second, holding that “plaintiff . . . must point to something in the advertis[ing] to allow a reasonable consumer to draw the inference that ‘brewed with,’ ‘made with’ or ‘uses’ corn syrup means that corn syrup is *in* the final product.”¹⁵⁵⁶ With the plaintiff unable to do so, and with the court declining the plaintiff’s invitation to accept the defendant’s alleged intent to deceive consumers as a substitute showing,¹⁵⁵⁷ the plaintiff’s bid for preliminary injunctive relief fell short.

(3) Opinions Deferring Resolution of the Falsity Inquiry

As always, some courts looked skeptically at assertions by defendants that false advertising causes of action failed adequately to aver the falsity of the underlying representation. Chief among them was the Eleventh Circuit, which reversed a district’s grant of a motion to dismiss in a dispute between manufacturers of nutritional supplements.¹⁵⁵⁸ According to the plaintiff, the defendant’s packaging misrepresented the nature and source of the protein contained in the defendant’s supplement. Specifically, the plaintiff asserted, the defendant’s packaging asserted that each serving of the defendant’s supplement contained 25 grams of six particular proteins when, in fact, the defendant spiked its supplement with “free form amino acids and non-protein ingredients” that left each serving with only 17.914 grams of the six proteins.¹⁵⁵⁹ Although crediting the defendant’s argument that “the Food and Drug Administration permits protein calculations based on free-form amino acids and other nitrogen-containing non-protein ingredients,”¹⁵⁶⁰ the court was unwilling to agree with the district court that the agency’s practice in that respect necessarily rendered the defendant’s labels nonactionable as a matter of law. On the

¹⁵⁵⁵ See *MillerCoors, LLC v. Anheuser-Busch Cos.*, 385 F. Supp. 3d 730, 733 (W.D. Wis.), *modified*, No. 19-cv-218-wmc, 2019 WL 4187489 (W.D. Wis. Sept. 4, 2019), *and modified*, No. 19-cv-218-wmc, 2019 WL 4247725 (W.D. Wis. Sept. 6, 2019), *remanded on other grounds*, 940 F.3d 922 (7th Cir. 2019).

Perhaps significantly, the defendant itself used corn syrup in the substrates it used to produce a number of its other brands of beer. *Id.* at 735 n.5 (“For example, Bud Ice, Natural Light, Natural Ice, Busch Light, Rolling Rock, Stella Artois Cidre, Stella Artois Spritzer and Bon & Viv Sparking White are brewed [by the defendant] with corn syrup.”).

¹⁵⁵⁶ *Id.* at 749.

¹⁵⁵⁷ *Id.* at 753-54.

¹⁵⁵⁸ See *Hi-Tech Pharm., Inc. v. HBS Int’l Corp.*, 910 F.3d 1186 (11th Cir. 2018).

¹⁵⁵⁹ *Id.* at 1197.

¹⁵⁶⁰ *Id.* at 1198.

contrary, the court held, “[b]ased on the total impression given by the label, it is plausible that only sophisticated consumers schooled in federal regulations or nutrition science would understand or even suspect that free-form amino acids or other non-protein ingredients form any part of [the defendant’s] stated 25 grams of protein per serving.”¹⁵⁶¹ The plaintiff’s Section 43(a) claim therefore survived to the proof stage.

Another failed motion to dismiss also arose in a dispute between pharmaceutical manufacturers.¹⁵⁶² The plaintiff accused the lead defendant of marketing an unapproved product in a manner suggesting the product was, in fact, approved; that defendant responded by arguing that the plaintiff’s allegations of false advertising failed to state a claim because “simply selling an unapproved drug is not actionable under the Lanham Act absent an affirmative representation of approval, and [the lead defendant] has not made an affirmative representation of approval.”¹⁵⁶³ Weighing the motion, the court noted that the plaintiff’s complaint recited that buyers believed all prescribed drugs identified on price lists such as those distributed by the lead defendant were approved by the FDA and, additionally, that surveys of pharmacists disclosed confusion on the same issue even among them. Those averments, the court held, sufficiently stated a cause of action for false advertising.¹⁵⁶⁴

Other accusations of falsity did not lend themselves to disposition on motions for summary judgment. Such was the case in a challenge brought by one producer of a glucomannan-based dietary weight-loss supplement against another.¹⁵⁶⁵ One set of disputed statements by the counterclaim defendant related to two third-party scientific studies on the efficacy of glucomannan (a soluble-viscous fiber derived from the root of the Konjac plant) itself, and not on the efficacy of the counterclaim defendant’s product, which included ingredients in addition to glucomannan. One of those studies concluded that male participants lost an average of 4.93 pounds and that 78 percent of the lost weight was attributable to reduced fat. In reliance on those findings, the counterclaim defendant advertised its supplement using the latter number while also representing to consumers that the supplement was “clinically tested.” The counterclaim plaintiff argued the advertising was literally false because the study had not addressed the counterclaim

¹⁵⁶¹ *Id.*

¹⁵⁶² See *Genus Lifesciences Inc. v. Lannett Co.*, 378 F. Supp. 3d 823 (N.D. Cal.), *reconsideration denied*, No. 18-cv-07603-WHO, 2019 WL 4168958 (N.D. Cal. Sept. 3, 2019).

¹⁵⁶³ *Id.* at 832.

¹⁵⁶⁴ *Id.* at 834.

¹⁵⁶⁵ See *Obesity Research Inst., LLC v. Fiber Research Int’l, LLC*, 310 F. Supp. 3d 1089 (S.D. Cal.), *motion to certify denied*, No. 15-cv-00595-BAS-MDD, 2018 WL 1791611 (S.D. Cal. Apr. 16, 2018).

defendant's supplement, but it failed to convince the court of the counterclaim defendant's liability beyond material dispute. As the court noted, "[e]ach side highlights different aspects of the glucomannan root, including its production conditions, testing methods, and viscosity results. Additionally, the parties engage in various arguments regarding why their evidence should be accepted and the other side's discredited. These arguments are best saved for a jury."¹⁵⁶⁶

The parties' cross-motions for summary judgment similarly led to a procedural stalemate on another aspect of the counterclaim defendant's advertising, namely, that its supplements contained "no known allergens." The counterclaim plaintiff argued that representation was false based on what it characterized as "excessive sulfite levels," to which the counterclaim defendant responded that the FDA did not classify sulfites as known allergens. Denying both parties' motions, the court determined from the summary judgment record that:

[A] genuine issue of material fact remains as to which standard or definition should apply to advertisements regarding what "known allergens" are contained in a dietary supplement. It is possible for a jury to find that this statement only applied to the commonly known major food allergies, such as nuts, milk, and other common allergies, or that it instead meant additional irritants, such as sulfites.¹⁵⁶⁷

The same result held in another case in which a manufacturer of pharmaceutical products took issue with the claim of a drug compounder and its marketing company¹⁵⁶⁸ that the "unique combination of active and inactive ingredients [of the compounder's preparations] has been selected to produce an outcome that is clinically superior and materially different to that which is commercially available."¹⁵⁶⁹ Rejecting the plaintiff's challenge to that representation as literally false as matter of law, the court found from the summary judgment record that "[t]here is no doubt that [compounded] drugs can improve patient outcome and provide drugs that may otherwise be unavailable, for example if a patient has a specific allergy to a type of medication."¹⁵⁷⁰ This meant "[t]here is at least a dispute of fact as to whether the statements regarding superiority of the drugs are literally false where the drugs may

¹⁵⁶⁶ *Id.* at 1119.

¹⁵⁶⁷ *Id.* at 1124.

¹⁵⁶⁸ *See Allergan USA, Inc. v. Prescribers Choice, Inc.*, 364 F. Supp. 3d 1089 (C.D. Cal. 2019).

¹⁵⁶⁹ *Id.* at 1112.

¹⁵⁷⁰ *Id.*

allow a patient relief where she cannot tolerate a more traditional prescription.”¹⁵⁷¹

ii. Actual or Likely Deception

As always, courts recognized two ways in which plaintiffs could demonstrate the actual or likely deception necessary to a successful cause of action for false advertising. First, they typically applied a presumption of actual or likely deception in cases presenting either literally false advertising or intentional misconduct by the defendant.¹⁵⁷² In contrast, however, they also held that “if a plaintiff’s theory of recovery is premised upon a claim of implied falsehood, a plaintiff must demonstrate, by extrinsic evidence, that the challenged advertisements tend to mislead or confuse consumers.”¹⁵⁷³

At least one prevailing plaintiff successfully availed itself of both a presumption of deception and extrinsic evidence that deception had in fact occurred.¹⁵⁷⁴ The case arose from a particularly brazen set of false representations by the defendants, which included spurious claims that the defendants were responsible for a number of major construction projects on which either the plaintiff or a subsidiary of the plaintiff had actually worked. In granting the plaintiff’s motion for summary judgment, the court held the presumption of actual or likely deception triggered by the plaintiff’s showing of both literal falsity and intentional misconduct by the defendants.¹⁵⁷⁵ Ultimately, however, the presumption was unnecessary to the plaintiff’s case, for the plaintiff also successfully introduced testimony that a former employee of a subsidiary of the

¹⁵⁷¹ *Id.*

¹⁵⁷² *See, e.g.,* De Simone v. VSL Pharm., Inc., 395 F. Supp. 3d 617, 623 (D. Md. 2019) (“If an advertisement is literally false, a party can succeed on a false advertising claim without evidence of any consumer deception.”), *appeal docketed sub nom* De Simone v. Alfasigma USA, Inc., No. 19-1731 (4th Cir. July 12, 2019), and *appeal docketed sub nom.* De Simone v. Leadiant Biosciences, Inc., No. 19-1762 (4th Cir. July 22, 2019); Diamond Resorts Int’l, Inc. v. Aaronson, 371 F. Supp. 3d 1088, 1105 (M.D. Fla. 2019) (“If an advertisement is literally false, there is no requirement to present evidence of consumer deception.”); Allergan USA, Inc. v. Prescribers Choice, Inc., 364 F. Supp. 3d 1089, 1113 (C.D. Cal. 2019) (“Deliberately false comparative claims give rise to a rebuttable presumption of actual deception. Because the [defendants’] statements . . . are literally false, there is a rebuttable presumption of actual deception.” (citation omitted)); Obesity Research Inst., LLC v. Fiber Research Int’l, LLC, 310 F. Supp. 3d 1089, 1124 (S.D. Cal.) (presuming actual or likely deception as a matter of law based on counterclaim plaintiff’s demonstration of literally false advertising), *motion to certify denied*, No. 15-cv-00595-BAS-MDD, 2018 WL 1791611 (S.D. Cal. Apr. 16, 2018).

¹⁵⁷³ *De Simone*, 395 F. Supp. 3d at 623; *accord* *Diamond Resorts Int’l*, 371 F. Supp. 3d at 1105.

¹⁵⁷⁴ *See* AECOM Energy & Constr., Inc. v. Ripley, 348 F. Supp. 3d 1038 (C.D. Cal. 2018), *reconsideration denied*, No. CV 17-5398-RSWL-SSx, 2019 WL 2610953 (C.D. Cal. Apr. 24, 2019), *appeal docketed*, No. 19-55588 (9th Cir. May 23, 2019).

¹⁵⁷⁵ *Id.* at 1056.

plaintiff had approached the defendants about a particular project while under the impression he was dealing with the subsidiary.¹⁵⁷⁶

While granting a preliminary injunction motion in a case between two prominent beer producers, a different court accepted the extrinsic evidence of deception proffered by the plaintiff after rejecting the claim that the defendant had acted with an intent to deceive consumers.¹⁵⁷⁷ The false advertising at issue suggested that the plaintiff's beer contained corn syrup. One component of the plaintiff's showing was testimony by an expert witness that a net 35 percent of survey respondents believed corn syrup was indeed present in the plaintiff's beer; although the defendant's counterexpert took issue with certain aspects of the plaintiff's survey, his criticisms did not require the court to reject the survey results out of hand.¹⁵⁷⁸ The court also proved receptive to the plaintiff's submission of consumer comments, 18 percent of which allegedly indicated that the commentators were likely to end or decrease their purchases of the plaintiff's beer.¹⁵⁷⁹ Finally, the plaintiff successfully introduced social media reaction to the defendant's advertising, of which its expert testified that "28.6% of consumer posts include information that indicates the author holds the mistaken belief that corn syrup used in brewing is present in the final product (the beer itself)."¹⁵⁸⁰ Although the last two of those showings might not have sufficed standing alone, they still provided anecdotal evidence supporting the plaintiff's survey results.¹⁵⁸¹ The upshot was that "plaintiff's evidence is sufficient to support a finding at the preliminary injunction stage that it has some likelihood of success in proving defendant's advertisements deceived or have the tendency to deceive a substantial segment of consumers to believe that [the plaintiff's beer] actually contain[s] corn syrup."¹⁵⁸²

Another plaintiff also successfully invoked survey evidence of deception during a trial before a Utah federal district court.¹⁵⁸³ The issue at stake was whether the use of the word "local" as part of a tagline for baked goods either actually misled consumers into thinking those goods were produced within Utah (which, in fact,

¹⁵⁷⁶ *Id.*

¹⁵⁷⁷ *See MillerCoors, LLC v. Anheuser-Busch Cos.*, 385 F. Supp. 3d 730 (W.D. Wis.), *modified*, No. 19-cv-218-wmc, 2019 WL 4187489 (W.D. Wis. Sept. 4, 2019), *and modified*, No. 19-cv-218-wmc, 2019 WL 4247725 (W.D. Wis. Sept. 6, 2019), *remanded on other grounds*, 940 F.3d 922 (7th Cir. 2019).

¹⁵⁷⁸ *Id.* at 757.

¹⁵⁷⁹ *Id.*

¹⁵⁸⁰ *Id.*

¹⁵⁸¹ *Id.*

¹⁵⁸² *Id.*

¹⁵⁸³ *See Bimbo Bakeries USA, Inc. v. Sycamore*, 372 F. Supp. 3d 1291 (D. Utah 2019), *appeal docketed*, No. 19-4040 (10th Cir. Mar. 22, 2019).

they were not) or was likely to do so. The plaintiff's survey yielded a net 28 percent confusion rate among respondents. With the court finding that rate adequate to support the jury's verdict of liability, the defendants attacked its methodology on grounds not disclosed by the opinion. Whatever they may have been, however, they did not convince the court, which applied the usual rule that "[f]laws in methodology typically relate only to the weight of the survey evidence."¹⁵⁸⁴

Survey evidence likewise assisted a different group of plaintiffs in defeating a defense motion for summary judgment.¹⁵⁸⁵ The defendants were an attorney and a law firm specializing in timeshare disputes, who, in the course of soliciting clients, disseminated allegedly false statements in commerce concerning the timeshare industry generally and the plaintiffs in particular. To prove the deceptive nature of the defendants' advertising, the plaintiffs adduced the results of surveys that, in the words of the plaintiffs' expert, established "a pattern of responses that provides compelling evidence that the [defendants'] websites communicate misleading information about the services provided by [the defendants] and disparaging content about time share management companies."¹⁵⁸⁶ He elaborated that "[a]cross multiple items there are statistically significant differences between the responses offered by survey participants who saw one of the [defendants'] websites and a control letter."¹⁵⁸⁷

Although not seeking to exclude the survey's results, the defendants attacked its methodology and the significance of the results. They first challenged the universe of respondents, which consisted of "adult consumers (age 18 years or more) in the United States who own or have ever owned a timeshare property" on the theory that it should have been limited to "timeshare owners *who want to get out of their timeshares*,"¹⁵⁸⁸ but the court disagreed "because access to the Subject Advertisements and Firm Website is not limited to Defendants' suggested survey audience, the Court finds no reason to discredit the . . . Survey Report based on the population used."¹⁵⁸⁹ The defendants then argued the court should disregard the results because the net confusion rate documented in them did not exceed the 20 percent threshold the defendants claimed was applicable: As to that contention, the court held, "Defendants ignore many cases finding percentages less than 20%

¹⁵⁸⁴ *Id.* at 1302 (quoting *OraLabs, Inc. v. Kind Grp.*, 2015 WL 4538442, at *4 (D. Colo. Jul. 28, 2015)).

¹⁵⁸⁵ *See Diamond Resorts Int'l, Inc. v. Aaronson*, 371 F. Supp. 3d 1088, 1105 (M.D. Fla. 2019).

¹⁵⁸⁶ *Id.* 1105-06.

¹⁵⁸⁷ *Id.* at 1106.

¹⁵⁸⁸ *Id.*

¹⁵⁸⁹ *Id.* at 1107.

sufficient, significant, and meaningful.”¹⁵⁹⁰ Finally, and in any case, the defendants failed to put forward their challenges through their own expert witness.¹⁵⁹¹

A final notable opinion reaching a finding of actual or likely deception did so based on survey evidence—and testimony from the survey expert on a subject unrelated to his survey.¹⁵⁹² The challenged advertising bore on the sugar content of a line of children’s drinkable yogurt. The advertising was literally true because it accurately reflected the average sugar content of the entire line, but it was false to the extent it suggested the content of individual products. The survey posited the following hypothetical to respondents:

The ACME and AJAX companies both sell mini (single serving) cups of ice cream. Both companies offer these mini cups in three flavors: cookies & cream, butter pecan, and mint chocolate chip. ACME’s mini cups contain 4 ounces of ice cream while AJAX’s contain 3.5 ounces. Now imagine you go into the store and see ACME’s ice cream mini cups. Each mini cup claims that it has 25 percent less fat than AJAX!¹⁵⁹³

The survey then asked respondents two questions: (1) whether they were more likely to assume the comparison in the hypothetical was based on fat content per cup or, alternatively, per ounce; and (2) whether they were more likely to assume that the comparison was based on each flavor independently or the average of all three flavors.

The survey’s results led the court to conclude that “[r]espondents were far more likely to interpret a comparative statement such as [the defendant’s] “33% less sugar claim” in the context of sugar content per serving (rather than per ounce) and as related to a specific flavor in question (rather than based on the averaging of all flavors).”¹⁵⁹⁴ Worse still from the defendant’s perspective, “only a very small fraction of respondents was likely to interpret the comparative claim posed in the survey to refer *both* to sugar content per ounce *and* derive from averaging across all flavors—indicating that very few consumers are likely to understand [the defendant’s] advertisement.”¹⁵⁹⁵ Although the defendant’s counter-expert faulted the plaintiff’s expert for failing to use a control, the court rejected that criticism because “a control group [was unnecessary] to guard against bias or pre-existing beliefs about the parties or their

¹⁵⁹⁰ *Id.*

¹⁵⁹¹ *Id.*

¹⁵⁹² See *Danone, US, LLC v. Chobani, LLC*, 362 F. Supp. 3d 109 (S.D.N.Y. 2019).

¹⁵⁹³ *Id.* at 115.

¹⁵⁹⁴ *Id.* at 120.

¹⁵⁹⁵ *Id.*

products in the sort of study [the plaintiff's expert conducted]; his survey implicated neither [party] and was deliberately designed in a way that ruled out any consumer bias in favor of or against either company.”¹⁵⁹⁶

The court then found the plaintiff's expert's report probative for another reason. According to the defendant, two explanatory footnotes on its packaging cured any deception that might otherwise have arisen from its representations. The court rejected that argument because “[a]s revealed in [the expert's] review of the academic literature, numerous studies across different types of products reveal that consumers are unlikely to notice or pay attention to [the defendant's] hard-to-find and hard-to-read ‘disclosure’ footnotes, and frankly, the disclosures contained in those footnotes are not comprehensible.”¹⁵⁹⁷ Although the court ultimately denied the plaintiff's preliminary injunction motion, it therefore did not do so because the plaintiff had failed to prove a likelihood of success on the merits of its claims.

iii. Materiality

The requirement that challenged advertising be material for liability led to diverging opinions from two California federal district courts. Although a showing of literally false advertising does not create a presumption of materiality in all jurisdictions, it sometimes does in the Ninth Circuit.¹⁵⁹⁸ In an application of that rule, the first court concluded that the literal falsity of the defendants' representations excused the plaintiff from having to make an affirmative showing of materiality; independent of the presumption, the court held the plaintiff had carried its burden as a matter of law through testimony of a confused potential purchaser of the defendants' proffered services.¹⁵⁹⁹

In contrast, the second court to address the issue held that “[t]he Court is not convinced that the Ninth Circuit has likewise determined that materiality is presumed for actually false statements, nor has [the counterclaim plaintiff] cited to a Ninth Circuit case stating this.”¹⁶⁰⁰ The counterclaim plaintiff's heavy reliance on the presumption led the court to deny most of its motion for summary judgment on the issue of materiality. There was one

¹⁵⁹⁶ *Id.*

¹⁵⁹⁷ *Id.* at 121.

¹⁵⁹⁸ See *U-Haul Int'l Inc. v. Jartran, Inc.*, 793 F.2d 1034, 1040-41 (9th Cir. 1986).

¹⁵⁹⁹ See *AECOM Energy & Constr., Inc. v. Ripley*, 348 F. Supp. 3d 1038, 1056 (C.D. Cal. 2018), *reconsideration denied*, No. CV 17-5398-RSWL-SSx, 2019 WL 2610953 (C.D. Cal. Apr. 24, 2019), *appeal docketed*, No. 19-55588 (9th Cir. May 23, 2019).

¹⁶⁰⁰ See *Obesity Research Inst., LLC v. Fiber Research Int'l, LLC*, 310 F. Supp. 3d 1089, 1125 (S.D. Cal.), *motion to certify denied*, No. 15-cv-00595-BAS-MDD, 2018 WL 1791611 (S.D. Cal. Apr. 16, 2018).

exception, however, which related to the counterclaim defendant's (literally false) claim that a particular scientific study cited in its advertising had been conducted by a "major university." As to the materiality of that representation, the court found as a matter of law that "a 'major university' affiliation invokes a level of legitimacy and assurance for a consumer that would likely affect a consumer's decision to purchase [the counterclaim defendant's product]."¹⁶⁰¹ Presumption or no presumption, the counterclaim plaintiff therefore prevailed on that issue, and the court therefore granted its motion for summary judgment.

Two other California federal district courts reached findings of materiality as a matter of law without addressing the possible applicability of the presumption one way or another. The first court did so in an action brought by a national farmers' organization and its state chapter against a former affiliate and its leader that had engaged in post-affiliation promotional practices creating the impression the defendants remained a part of the lead plaintiff's organization.¹⁶⁰² The summary judgment record established that the defendants had successfully convinced the parties' members of the necessity of paying dues to the lead defendant to maintain their good standing with the lead plaintiff. Based on that undisputed showing by the lead plaintiff, the court concluded that "defendants have made false and misleading representations in interstate commerce that have materially affected and injured plaintiff[], and thus . . . [plaintiff] is entitled to summary judgment on its claim for federal false advertising."¹⁶⁰³

The second court found materiality beyond legitimate dispute in a case in which the plaintiff manufactured pharmaceutical products, and the defendants sold and marketed drugs produced at a compounding pharmacy.¹⁶⁰⁴ In finding as a matter of law that the defendants had falsely misrepresented that the FDA had approved the facility producing their drugs and that their business model was FDA-compliant, the court neither applied nor rejected a presumption of materiality. Instead, it held the prerequisite for liability satisfied based on the plaintiff's summary judgment showing, which demonstrated both that "[Defendants'] sales representatives have represented to customers that Defendants comply with the law because they knew that compliance with the law was an important issue to customers when they make a

¹⁶⁰¹ *Id.* at 1126.

¹⁶⁰² See *Nat'l Grange of the Order of Patrons of Husbandry v. Cal. Guild*, 334 F. Supp. 3d 1057 (E.D. Cal.), *reconsideration denied sub nom.* *Nat'l Grange v. Cal. Guild*, No. 2:16-cv-0201 WBS DB, 2018 WL 5270563 (E.D. Cal. Oct. 22, 2018), *appeal docketed*, No. 18-16671 (9th Cir. Sept. 5, 2018).

¹⁶⁰³ *Id.* at 1067.

¹⁶⁰⁴ See *Allergan USA, Inc. v. Prescribers Choice, Inc.*, 364 F. Supp. 3d 1089 (C.D. Cal. 2019).

decision”¹⁶⁰⁵ and that “some of the false commercial promotions were made in direct follow-up to customer questions about quality and FDA compliance.”¹⁶⁰⁶ The final nail of the defendants’ coffin was survey evidence indicating that “27% responded that they agreed with the statement, ‘I worry about the legality of in-office dispensing [of drugs such as those produced by the defendants].’”¹⁶⁰⁷

The parade of pro-plaintiff summary judgment opinions extended to at least one federal district court in Florida. When an attorney and his law firm solicited clients by targeting timeshare developers, a group of plaintiffs active in that industry challenged the accuracy of advertising placed by the attorney and his firm, as well as of the content on their website.¹⁶⁰⁸ Moving for summary judgment of nonliability, the defendants argued that the lack of direct evidence that any of their clients had stopped making payments to the plaintiffs or had initiated arbitrations aimed at terminating their contracts with the plaintiffs precluded the plaintiffs from establishing the materiality of the defendants’ advertising. The court, however, held that “this assertion overlooks the circumstantial evidence in the record that could show that the Subject Advertisements influenced the ‘purchasing decisions’ of people exposed to them—so this element survives summary judgment.”¹⁶⁰⁹ That circumstantial evidence consisted in part of an expert witness report “show[ing] a breakdown of the temporal correlation between when [Plaintiffs’ timeshare] members retained Defendants and when they stopped making payments owed under their Timeshare Contracts.”¹⁶¹⁰ It also included “evidence that many of Defendants’ Diamond Clients found Defendants through the Firm Website—where the Subject Advertisements were found.”¹⁶¹¹ “So,” the court observed, “a reasonable jury could find that something in the Subject Advertisements influenced the decision to stop making payments or to pursue arbitration.”¹⁶¹² Moreover, and in any case, a jury might reasonably find that the defendants had misrepresented an inherent characteristic of the plaintiffs’ services, in which case materiality would be presumed.¹⁶¹³

Of course, some disputes over materiality were resolved only through trials. A finding of materiality as a factual matter transpired in litigation over the accuracy of the defendants’

¹⁶⁰⁵ *Id.* at 1113.

¹⁶⁰⁶ *Id.*

¹⁶⁰⁷ *Id.*

¹⁶⁰⁸ *See* *Diamond Resorts Int’l, Inc. v. Aaronson*, 371 F. Supp. 3d 1088 (M.D. Fla. 2019).

¹⁶⁰⁹ *Id.* at 1108.

¹⁶¹⁰ *Id.*

¹⁶¹¹ *Id.*

¹⁶¹² *Id.*

¹⁶¹³ *Id.* at 1108-09.

representations concerning the particular strains of bacteria in a probiotic mix, as well as their representations concerning the location in which their mix was produced.¹⁶¹⁴ In affirming a jury finding of liability, the court noted as an initial matter that “[a] Lanham Act false statement is material if it is ‘likely to influence the purchasing decision.’”¹⁶¹⁵ In the case at hand, the reasonableness of the jury’s finding of liability with respect to the composition of the defendants’ mix was apparent because “[t]he false statements on the number and proportions of strains are plainly material because they related to an ‘inherent quality or characteristic’ of [the mix].”¹⁶¹⁶ Moreover, the same was true where the defendants’ representations about the manufacturing facility were concerned:

[T]he jury could reasonably infer that [those] false claim[s] . . . could influence purchasing decisions by causing purchasers to mistakenly believe that [the parties’ respective mixes] were actually the same and that [the defendants’ mix] was thus supported by the history of clinical trials relating to [the plaintiffs’ mix], a history that, according to [a witness], was necessary to convince doctors to prescribe the product.¹⁶¹⁷

A Utah federal district court similarly declined to overturn a jury’s finding of materiality in a lawsuit challenging the defendants’ use of the word “local” in connection with bread baked outside of that state.¹⁶¹⁸ In support of its case at trial, the plaintiff successfully proffered testimony from an expert witness that a net 28 percent of survey respondents were misled by the defendants’ advertising. The court remarked of this showing that “[h]aving received evidence of consumer confusion, the jury properly determined that [the defendants’] use of the term ‘local’ was material to a bread purchaser’s decision.”¹⁶¹⁹ It then elaborated on this point:

A misrepresentation is material if “it would have some effect on consumers’ purchasing decisions.” This effect does not have to be a dominant factor so long as it would have some impact on a purchase decision. Further, a plaintiff need only

¹⁶¹⁴ See *De Simone v. VSL Pharm., Inc.*, 395 F. Supp. 3d 617 (D. Md. 2019), *appeal docketed sub nom De Simone v. Alfasigma USA, Inc.*, No. 19-1731 (4th Cir. July 12, 2019), and *appeal docketed sub nom. De Simone v. Lediand Biosciences, Inc.*, No. 19-1762 (4th Cir. July 22, 2019).

¹⁶¹⁵ *Id.* at 627 (quoting *Cashmere & Camel Hair Mfrs. Inst. v. Saks Fifth Ave.*, 284 F.3d 302, 311 (1st Cir. 2002)).

¹⁶¹⁶ *Id.* (quoting *Cashmere & Camel Hair Mfrs. Inst.*, 284 F.3d at 311-12).

¹⁶¹⁷ *Id.* at 628.

¹⁶¹⁸ See *Bimbo Bakeries USA, Inc. v. Sycamore*, 372 F. Supp. 3d 1291 (D. Utah 2019), *appeal docketed*, No. 19-4040 (10th Cir. Mar. 22, 2019).

¹⁶¹⁹ *Id.* at 1302.

prove a likelihood that a particular misrepresentation would be material to consumer purchase decisions, and need not prove actual influence on consumer decision making.¹⁶²⁰

iv. Interstate Commerce

The requirement, at least for purpose of a claim under Section 43(a), that a false misrepresentation be disseminated in interstate commerce proved an easily overcome obstacle to most plaintiffs, especially in cases in which the challenged advertising occurred online.¹⁶²¹ Chief among them was a provider of construction equipment and engineering services that objected to false claims that the defendants were responsible for a series of major construction projects on which the plaintiff and one of its subsidiaries had actually worked.¹⁶²² Those claims appeared on a website accessible at two domain names based on marks owned by the plaintiff, and that circumstance led to a finding as a matter of law that the plaintiff had satisfied this prerequisite for liability: “[I]t is undisputed that Defendants caused their false statements to enter interstate commerce, as they collectively used their online website and email addresses connected to the same domain name.”¹⁶²³

v. Damage and Causation

The twin requirements of damage and causation continued to play increasing roles in litigation involving claims of false advertising, with California federal district courts leading the way in adopting lenient approaches to them. For example, having come up short in their efforts to create factual disputes on the other requirements for liability for false advertising, a group of defendants argued in response to a motion for summary judgment that the plaintiff had failed to disclose a calculation of its alleged damages.¹⁶²⁴ That argument came in a case in which the defendants had falsely claimed credit for a number of major construction projects on which the plaintiff, and not the defendants, actually had worked. The court proved an unreceptive audience, holding that

¹⁶²⁰ *Id.* at 1302-03 (footnotes omitted).

¹⁶²¹ *See, e.g., Nat'l Grange of the Order of Patrons of Husbandry v. Cal. Guild*, 334 F. Supp. 3d 1057, 1066 (E.D. Cal.) (“Communications made on public websites are made in interstate commerce.”), *reconsideration denied sub nom. Nat'l Grange v. Cal. Guild*, No. 2:16-cv-0201 WBS DB, 2018 WL 5270563 (E.D. Cal. Oct. 22, 2018), *appeal docketed*, No. 18-16671 (9th Cir. Sept. 5, 2018).

¹⁶²² *See AECOM Energy & Constr., Inc. v. Ripley*, 348 F. Supp. 3d 1038 (C.D. Cal. 2018), *reconsideration denied*, No. CV 17-5398-RSWL-SSx, 2019 WL 2610953 (C.D. Cal. Apr. 24, 2019), *appeal docketed*, No. 19-55588 (9th Cir. May 23, 2019).

¹⁶²³ *Id.* at 1056.

¹⁶²⁴ *See id.* at 1047.

“whether or not Plaintiff sufficiently disclosed its calculation is irrelevant because monetary damages is not the only manner in which a party can suffer injury under the Lanham Act.”¹⁶²⁵ It then credited the plaintiff’s showing that:

Defendants’ false statements on their website have lessened the goodwill in [Plaintiff’s] brand, including that Plaintiff no longer has control over its business reputation. As Defendants do not provide any evidence to the contrary, there is no triable issue that Plaintiff has suffered and is likely to continue to suffer injury in the loss of its goodwill in the . . . brand.¹⁶²⁶

A grant of the plaintiff’s motion for summary judgment followed.

Likewise, in another case originating in the Golden State, the counterclaim plaintiff similarly failed to produce a calculation of the actual damages it allegedly had suffered as a result of the counterclaim defendant’s advertising of its weight-loss supplement products.¹⁶²⁷ That failure did not lead to a defense victory, however. Instead, the court credited testimony from the plaintiff’s witnesses that they had sought to enter the weight-loss supplement market but had been “shut out” of that market by the counterclaim defendant’s advertising.¹⁶²⁸ Of equal importance, the same witnesses expressed concern that the allegedly less effective supplements sold by the counterclaim defendant would affect the counterclaim plaintiff’s reputation. In denying both parties’ motions for summary judgment, the court disclaimed any intent to “discount the lack of financial documents and analysis documenting [the counterclaim plaintiff’s] damages, but finds that the weighing of each party’s evidence (or lack thereof) is best suited for a jury.”¹⁶²⁹

Litigation in the District of Maryland produced a finding of damage and causation following a trial between two manufacturers of probiotic products.¹⁶³⁰ The gravamen of the plaintiffs’ claims was that the defendants falsely represented their probiotic mix as having the same bacterial strains as that of the plaintiffs. The jury hearing the case found injury and causation, and the court declined to set that verdict aside in response to the defendants’ post-trial

¹⁶²⁵ *Id.* at 1056.

¹⁶²⁶ *Id.* at 1057 (citations omitted).

¹⁶²⁷ *See Obesity Research Inst., LLC v. Fiber Research Int’l, LLC*, 310 F. Supp. 3d 1089 (S.D. Cal.), *motion to certify denied*, No. 15-cv-00595-BAS-MDD, 2018 WL 1791611 (S.D. Cal. Apr. 16, 2018).

¹⁶²⁸ *Id.* at 1127.

¹⁶²⁹ *Id.*

¹⁶³⁰ *See De Simone v. VSL Pharm., Inc.*, 395 F. Supp. 3d 617 (D. Md. 2019), *appeal docketed sub nom De Simone v. Alfaisigma USA, Inc.*, No. 19-1731 (4th Cir. July 12, 2019), and *appeal docketed sub nom. De Simone v. Leadiant Biosciences, Inc.*, No. 19-1762 (4th Cir. July 22, 2019).

motions. “As a threshold issue,” the court held, “this element does not require proof of actual damages such as lost sales to [the plaintiffs].”¹⁶³¹ Moreover, the plaintiffs had successfully proffered expert testimony to the effect that doctors would not prescribe a product if it had not been the subject of clinical trials, which the defendants’ mix had not been (but which the plaintiffs’ mix had).¹⁶³² They also had put before the jury testimony from another expert to the effect “that it was important to her as a dietician to know what strains of bacteria were in [the defendants’ mix] and whether those strains matched up with the product that was the subject of clinical tests so that she could make informed recommendations to her clients.”¹⁶³³ “This evidence,” the court concluded, “was sufficient for the jury reasonably to conclude that the false statements caused injury or were likely to cause injury to [the plaintiffs],”¹⁶³⁴ especially because, in light of the defendants’ claim to sell a fungible product, “the path from the false advertising to the plaintiffs’ injury is shorter and more direct.”¹⁶³⁵

A Florida district court did not reach an actual finding of fact under the causation prong of the false-advertising inquiry, choosing instead to deny a defense motion for summary judgment on the issue.¹⁶³⁶ The defendants sought to secure clients for their legal practice by encouraging purchasers of timeshares to consider challenging their contracts; in the process, they placed advertising and posted content on their website questioning the ethics and legality of the practices of timeshare developers, including those of the plaintiffs. In arguing that the plaintiffs had failed as a matter of law to prove damage arising from the defendants’ conduct, the defendants cited the absence from the challenged advertisements of express directions to viewers to stop making payments to the plaintiffs or to initiate arbitrations as a means of escaping their contracts with the plaintiffs. The court, however, noted “competent circumstantial evidence to show that a reasonable jury could find that the Subject Advertisements proximately caused [the plaintiffs’] alleged injuries.”¹⁶³⁷ That circumstantial evidence fell into four general categories: (1) testimony from some of the defendants’ clients that they had viewed the advertising;¹⁶³⁸ (2) Google analytics “show[ing] that the Subject Advertisements were viewed thousands of times, revealing the widespread exposure to the Subject

¹⁶³¹ *Id.* at 628.

¹⁶³² *Id.* at 630.

¹⁶³³ *Id.* at 630-31.

¹⁶³⁴ *Id.* at 631.

¹⁶³⁵ *Id.*

¹⁶³⁶ *See Diamond Resorts Int’l, Inc. v. Aaronson*, 371 F. Supp. 3d 1088 (M.D. Fla. 2019).

¹⁶³⁷ *Id.* at 1009-10.

¹⁶³⁸ *Id.* at 1110.

Advertisements”;¹⁶³⁹ (3) proof that clients exposed to the advertising on the defendants’ website had “ceased paying [Plaintiffs] within a thirty-day period before retaining Defendants for eleven matters and after retaining Defendants in another twenty matters”;¹⁶⁴⁰ and (4) testimony from the plaintiffs’ survey expert that “the Subject Advertisements are likely to cause viewers to hire Defendants and to stop making payments on their Timeshare Contracts.”¹⁶⁴¹ Especially because “Defendants cite no authority to support their contention that false advertisements must expressly tell viewers to withhold trade from a plaintiff or that the false advertising must be the only reason behind a consumer’s actions for a plaintiff to prevail on a false advertising claim,”¹⁶⁴² their summary judgment motion was without merit.

d. False Endorsement and Violations of the Right of Publicity

Two of the more interesting reported opinions over the past year addressed ownership of persona-based rights in cases involving deceased celebrities. The first came in a dispute between entities formed by relatives of the late, great artist Bob Ross.¹⁶⁴³ The issue at stake was which of the parties owned Ross’s post-mortem right of publicity, and the parties’ cross-motions for summary judgment led to a victory for a corporation organized by Ross’s wife and two of his friends. That result held because of evidence and testimony that, during his lifetime, Ross had transferred his persona-based rights to that corporation; the absence from the summary judgment record of a signed copy of a written document that would have effected such a result did not mandate a contrary result. According to the court, “[w]hile there is no formal written agreement assigning those rights to [the prevailing defendant], there is ample evidence in the record supporting that the unsigned written agreement would have merely formalized Bob Ross’s oral grant of the exclusive rights to his intellectual property and right of publicity to [the defendant].”¹⁶⁴⁴

The second opinion issued from a court hearing a challenge to the use of Marilyn Monroe’s name and image on various goods.¹⁶⁴⁵ Relying on past decisions holding that third parties did not own any

¹⁶³⁹ *Id.*

¹⁶⁴⁰ *Id.*

¹⁶⁴¹ *Id.*

¹⁶⁴² *Id.*

¹⁶⁴³ See *RSR Art, LLC v. Bob Ross, Inc.*, 380 F. Supp. 3d 510 (E.D. Va. 2019), *appeal docketed*, No. 19-1483 (4th Cir. May 2, 2019).

¹⁶⁴⁴ *Id.* at 515.

¹⁶⁴⁵ See *A.V.E.L.A., Inc. v. Estate of Marilyn Monroe, LLC*, 364 F. Supp. 3d 291 (S.D.N.Y. 2019).

state-law rights of publicity,¹⁶⁴⁶ the counterclaim defendants argued that the counterclaim plaintiffs necessarily could not assert a claim of false endorsement under Section 43(a) based on the counterclaim defendants' conduct. The court disagreed, holding instead that the counterclaim plaintiffs' rights under Section 43(a) had a provenance not dependent on the existence of publicity-based rights under state law. Specifically, it found, Monroe's will left 75 percent of the residue of her estate to her acting teacher and twenty-five to her psychiatrist, after which an asset purchase agreement consolidated ownership in the lead counterclaim plaintiff. "Therefore," the court concluded, "an unbroken chain title extends from the decedent to the [lead counterclaim plaintiff]."¹⁶⁴⁷

When courts addressed the merits of false endorsement and right of publicity claims, plaintiffs generally came up short. One doing so was a corporation attempting to avail itself of a right of a publicity cause of action under Virginia law.¹⁶⁴⁸ The relevant statute provided that:

Any person whose name, portrait, or picture is used without . . . the written consent of such person, or if dead, of the surviving consort and if none, of the next of kin . . . for advertising purposes or for the purposes of trade . . . may maintain a suit in equity against the person, firm, or corporation so using such person's name."¹⁶⁴⁹

The court dismissed the plaintiff's cause of action for failure to state a claim, citing two reasons for that disposition. First, it held, "[a] corporate entity is not a 'person' under this statute. The provision discusses 'the death of the aggrieved person,' and only natural persons can die."¹⁶⁵⁰ "Furthermore," it observed, "in describing the party entitled to sue, the statute refers only to a 'person,' but in describing the parties subject to suit, the statute makes explicit the distinction between a 'person, firm, or corporation.'"¹⁶⁵¹

Litigation over a claim brought under the Florida right of publicity statute¹⁶⁵² before a federal district court in the same state ended in equally anticlimactic fashion.¹⁶⁵³ According to the

¹⁶⁴⁶ See *Milton H. Greene Archives, Inc. v. Marilyn Monroe LLC*, 692 F.3d 983 (9th Cir. 2012) (California law); *Shaw Family Archives, Ltd. v. CMG Worldwide, Inc.*, 486 F. Supp. 2d 309 (S.D.N.Y. 2007) (New York law).

¹⁶⁴⁷ *A.V.E.L.A.*, 364 F. Supp. 3d at 308.

¹⁶⁴⁸ See *BHR Recovery Cmty., Inc. v. Top Seek, LLC*, 355 F. Supp. 3d 416 (E.D. Va. 2018).

¹⁶⁴⁹ Va. Code Ann. § 8.01-40(A) (Repl. Vol. 2007).

¹⁶⁵⁰ *BHR Recovery Cmty.*, 355 F. Supp. 3d at 424 (citation omitted).

¹⁶⁵¹ *Id.* (quoting *Silver Ring Splint Co. v. Digisplint, Inc.*, 567 F. Supp. 2d 847, 855 (W.D. Va. 2008)).

¹⁶⁵² Fla. Stats. § 540.08(1) (West 2013).

¹⁶⁵³ See *Commodores Entm't Corp. v. McClary*, 324 F. Supp. 3d 1245 (M.D. Fla. 2018), *appeal docketed*, No. 19-12819 (11th Cir. July 25, 2019).

counterclaim plaintiff, a former member of The Commodores musical group, the lead counterclaim defendant—the group’s corporation—had misappropriated his identity by promoting its performances through a Facebook page displaying the counterclaim plaintiff’s image. Moving for summary judgment, the lead counterclaim defendant submitted declaration testimony that it did not maintain the page in question, and the counterclaim plaintiff failed to rebut that testimony in any way. Under the circumstances, the court held the lead counterclaim defendant was entitled to prevail without the need for a trial.¹⁶⁵⁴

Defense victories as a matter of law were not limited to litigation before federal courts. For example, class-action challenges by collegiate and professional athletes to the unauthorized for-profit use of their names and images have generally failed, and that usual outcome transpired in an appeal certified to the Supreme Court of Indiana by the Seventh Circuit.¹⁶⁵⁵ The athletes in question had sued two operators of online sports-fantasy leagues under the Indiana right-of-publicity statute, which provided that “[a] person may not use an aspect of a personality’s right of publicity for a commercial purpose during the personality’s lifetime or for one hundred (100) years after the date of the personality’s death without having obtained previous written consent.”¹⁶⁵⁶ Despite what otherwise would be a broad cause of action, the statute recognized several exceptions to liability, one of which protected “newsworthy” uses by defendants.¹⁶⁵⁷

In ruling against the plaintiffs, the court identified “several compelling reasons why our Court should understand the term ‘newsworthy value’ to incorporate fantasy sports operators’ use of players’ names, pictures, and statistics.”¹⁶⁵⁸ One was the “presumption that when the legislature enacts a statute, it is aware of the common law and does not intend to make a change unless it expressly or unmistakably implies that the common law no longer controls,”¹⁶⁵⁹ which the court found significant in light of decisions predating the statute’s enactment that construed broadly the concept of “newsworthiness.”¹⁶⁶⁰ A second reason was the court’s preference to avoid constitutional questions by construing the

¹⁶⁵⁴ *Id.* at 1254.

¹⁶⁵⁵ *See Daniels v. FanDuel, Inc.*, 109 N.E.3d 390 (Ind.), *conforming to answer to certified question*, 909 F.3d 876 (7th Cir. 2018).

¹⁶⁵⁶ Ind. Code § 32-36-1-8(a) (2017).

¹⁶⁵⁷ *Id.* § 32-36-1-1(c)(1)(B).

¹⁶⁵⁸ *Daniels*, 109 N.E.3d at 394.

¹⁶⁵⁹ *Id.* at 394-95.

¹⁶⁶⁰ *Id.* at 395-96.

statute in a manner not creating a conflict with the First Amendment.¹⁶⁶¹ In the final analysis:

Defendants' use of players' names, images, and statistics in conducting fantasy sports competitions bears resemblance to the publication of the same information in newspapers and websites across the nation. . . . This information is not stripped of its newsworthy value simply because it is placed behind a paywall or used in the context of a fantasy sports game. . . . It is difficult to find that the use of this otherwise publicly available information is somehow drastically different such that it should be placed outside the definition of "newsworthy."¹⁶⁶²

Likewise, an application of New York law by a trial court of that state led to the dismissal of a right-of-publicity cause of action against the creator of a video game.¹⁶⁶³ According to the plaintiff, a self-styled street basketball entertainer, the defendant's use of an avatar known as "Hot Sizzle" violated the plaintiff's rights to a nickname comprising the same words. The court found the plaintiff's averments lacking for two reasons, the first of which was that the plaintiff's public personality had not reached any magnitude of public notoriety; the second was that the defendant's use of the name was merely incidental.¹⁶⁶⁴

If some plaintiffs failed to fend off defense motions for summary judgment, so too did others fail to convince courts of the merit of their own motions. For example, although establishing their standing to prosecute a claim of false endorsement under Section 43(a) against the counterclaim defendants' use of Marilyn Monroe's name and image on various goods, including T-shirts, one group of counterclaim plaintiffs could not get that claim past the finish line as a matter of law.¹⁶⁶⁵ In denying the counterclaim plaintiffs' motion for summary judgment, the court held as a preliminary matter that:

To succeed on a claim for false endorsement, the plaintiff must show that the defendant "[i] made a false or misleading representation of fact; [ii] in commerce; [iii] in connection with goods or services; [iv] that is likely to cause consumer confusion as to the origin, sponsorship, or approval of the goods or services."¹⁶⁶⁶

¹⁶⁶¹ *Id.* at 396.

¹⁶⁶² *Id.* at 396-97 (citation omitted).

¹⁶⁶³ *See* *Champion v. Take Two Interactive Software, Inc.*, 100 N.Y.S.3d 838 (Sup. Ct. 2019).

¹⁶⁶⁴ *Id.* at 846-47.

¹⁶⁶⁵ *See* *A.V.E.L.A., Inc. v. Estate of Marilyn Monroe, LLC*, 364 F. Supp. 3d 291 (S.D.N.Y. 2019).

¹⁶⁶⁶ *Id.* at 306 (alterations in original) (quoting *Beastie Boys v. Monster Energy Co.*, 66 F. Supp. 3d 424, 455 (S.D.N.Y. 2014)).

Then, with respect to the final prong of this test, the court eschewed an application of the standard likelihood-of-confusion factors in favor of an inquiry focusing instead on:

the level of recognition [Marilyn Monroe] has among purchasers of [the counterclaim defendants'] t-shirts, the similarity between [Marilyn Monroe's] likeness and the likeness used by [the counterclaim defendant], the level of actual consumer confusion regarding who endorsed the t-shirts, [the counterclaim defendants'] intention in selecting [Marilyn Monroe's] image, the quality of [the counterclaim defendants'] products, and the sophistication of t-shirt purchasers.¹⁶⁶⁷

To satisfy this modified test, the plaintiff adduced “several pieces of evidence.”¹⁶⁶⁸ Those included misdirected complaints from consumers about the quality of the counterclaim defendants' goods, survey evidence documenting a net confusion rate among respondents of 20 percent, and the counterclaim defendants' use of the counterclaim plaintiffs' registered MARILYN mark on their goods; they also cited the counterclaim defendants' use of “images of Ms. Monroe with tattoos, deceased, or with sexually suggestive slogans,” as well as the impulse-purchase nature of the counterclaim defendants' T-shirts.¹⁶⁶⁹ The counterclaim defendants, however, responded with survey evidence of their own that only a net 8 percent of respondents believed that shirts featuring images of celebrities were endorsed by the celebrities. That result, they argued, arose from the pervasiveness of Monroe's image in the United States popular culture. The result was that a trial was necessary on the counterclaim plaintiffs' false endorsement cause of action (even if their showing was sufficient to defeat the counterclaim defendants' cross-motion for summary judgment). As the court held, “[t]he parties' debates over expert reports, the ubiquity of Ms. Monroe's image, and the relative merits of tattoos, hammer home the point that the reasonable consumer standard is a fact-intensive one. The Court cannot wholly credit the facts as either side presents them.”¹⁶⁷⁰

Despite this pattern of generally pro-defendant opinions, one group of plaintiffs—which included one Joel Wallach, a physician—managed to fend off a defense motion for summary judgment, even as they failed to convince the court of the merits of their own cross-

¹⁶⁶⁷ *Id.* at 309 (first, third, and fifth alterations in original) (quoting *Bruce Lee Enters. v. A.V.E.L.A., Inc.*, No. 10 Civ. 2333 (KMW), 2013 WL 822173, at *20 (S.D.N.Y. Mar. 6, 2013)).

¹⁶⁶⁸ *Id.* at 310.

¹⁶⁶⁹ *Id.*

¹⁶⁷⁰ *Id.* at 311.

motion.¹⁶⁷¹ The most interesting aspect of the resulting order was the court's treatment of the plaintiffs' claim that the defendants' 1-800-025-5524 telephone number violated Wallach's right of publicity under California law because the number was a mnemonic for 1-800-WALLACH. In denying the defendant's motion for summary judgment, the court held that:

Plaintiffs have submitted sufficient evidence to at least create a genuine issue of material fact as to whether the 1-800 number has acquired a secondary meaning that is synonymous and inexplicably intertwined with Dr. Wallach's name and likeness. . . . Thus, Plaintiffs' claim as to the 1-800 number does not fail as a matter of law.¹⁶⁷²

***e. Violations of Rights Under
Other State-Law Causes of Action***

i. Preemption of State-Law Causes of Action

Although holdings of federal preemption of state-law causes of action once occurred with relative frequency, they have tailed off in recent years. Nevertheless, one did occur at the hands of a New York federal district court hearing a case brought by a provider of secure mobile ticketing platforms for mass transit tickets.¹⁶⁷³ According to the plaintiff, the defendants had engaged in reverse passing off under New York law by practicing the technology covered by certain patents owned by the plaintiff, which the plaintiff asserted was likely to cause confusion among consumers as to the origin of the technology. The court made short work of that cause of action, agreeing with the defendants that it was preempted by federal patent law. In granting the defendants' motion to dismiss for failure to state a claim, the court characterized the plaintiff's cause of action as "essentially a claim for the unauthorized use of a patented product and [without] an extra element to qualitatively differentiate it from one of patent infringement."¹⁶⁷⁴

In contrast, a different New York federal district court rejected a claim of preemption by federal patent law.¹⁶⁷⁵ The defendants making that claim produced beer steins in the following shape, which, because of its strong resemblance to the Stanley Cup, predictably drew the attention of the National Hockey League:

¹⁶⁷¹ See *Youngevity Int'l v. Smith*, 350 F. Supp. 3d 919 (S.D. Cal. 2018).

¹⁶⁷² *Id.* at 923.

¹⁶⁷³ See *Bytemark, Inc. v. Xerox Corp.*, 342 F. Supp. 3d 496 (S.D.N.Y. 2018).

¹⁶⁷⁴ *Id.* at 507 (quoting *Carson Optical, Inc. v. Prym Consumer USA, Inc.*, 11 F. Supp. 3d 317, 333 (E.D.N.Y. 2014)).

¹⁶⁷⁵ See *Nat'l Hockey League v. Hockey Cup LLC*, 129 U.S.P.Q.2d 1354 (S.D.N.Y. 2019).



Seeking the dismissal of the NHL's state (and, improbably, federal) law claims, the defendants claimed preemption under the Supreme Court's decisions in *Sears, Roebuck & Co. v. Stiffel Co.*¹⁶⁷⁶ and *Compco Corp. v. Day-Brite Lighting, Inc.*,¹⁶⁷⁷ in each of which the Court invalidated efforts to protect unpatented lamp designs under the Illinois common law. The court quite properly rejected that argument:

In *Sears-Compco* the Court held merely that a state may not, through its law banning unfair competition, undermine the federal patent laws by prohibiting the copying of an article that is protected by neither a federal patent nor a federal copyright. . . . This consideration does not apply in a trademark infringement action where the plaintiff does not assert exclusive rights to the sale of a product but merely to a mark indicating its origin or sponsorship.¹⁶⁷⁸

“To the extent that the Defendants rely on *Sears-Compco* to argue that the NHL has failed to state a claim upon which relief can be granted,” the court therefore concluded, “this argument is unavailing.”¹⁶⁷⁹

ii. State-by-State Causes of Action

(A) *Illinois*

When a manufacturer of sunglasses accused a group of retailers of having trafficked in competitive goods bearing counterfeit imitations of the manufacturer's marks, the retailers asserted a variety of counterclaims, including one under Illinois law for trade

¹⁶⁷⁶ 376 U.S. 225 (1964), *reh'g denied*, 376 U.S. 973 (1964).

¹⁶⁷⁷ 376 U.S. 234 (1964), *reh'g denied*, 377 U.S. 913 (1964).

¹⁶⁷⁸ *Nat'l Hockey League*, 129 U.S.P.Q.2d at 1363 (alteration in original) (quoting *Dallas Cowboys Cheerleaders, Inc. v. Pussycat Cinema, Ltd.*, 604 F.2d 200, 204 (2d Cir. 1979)).

¹⁶⁷⁹ *Id.*

disparagement.¹⁶⁸⁰ According to the counterclaim plaintiffs, the counterclaim defendant had “published “false, disparaging, and highly damaging messages” about the counterclaim plaintiffs’ business, namely, that the counterclaim plaintiffs sold and serviced “counterfeit and non-genuine products.”¹⁶⁸¹ The counterclaim plaintiffs neglected to aver, however, that the counterclaim defendant’s alleged conduct had a nexus with the state of Illinois, and that omission led the counterclaim defendant to pursue a successful motion to dismiss the counterclaim plaintiffs’ cause of action.

In granting the motion, the court observed that “[t]here is ‘no single formula or bright-line test’ for determining whether a transaction occurs within Illinois.”¹⁶⁸² Nevertheless, it identified four factors relevant to determining whether a transaction occurred “primarily and substantially” in Illinois, which were: (1) the plaintiff’s residence; (2) the locus of the representation; (3) where the damage to the plaintiff occurred; and (4) whether the plaintiff communicated with the defendant in Illinois.¹⁶⁸³ The counterclaim plaintiffs’ allegations failed that test for several reasons, not the least of which was that “[i]t is undisputed that none of the [counterclaim plaintiffs] are residents of Illinois, but are rather foreign businesses organized and with principal places of business in the Cayman Islands, Hong Kong, and Italy.”¹⁶⁸⁴ Moreover, the complained-of conduct was nationwide, rather than Illinois-specific, and the counterclaim plaintiffs had failed to aver any allegations “permitting a plausible inference that [they have] suffered any damage in Illinois.”¹⁶⁸⁵ “Accordingly,” the court held, the counterclaim plaintiffs had not “alleged facts that, if true, establish a factual nexus with Illinois as required to entitle [them] to the relief [they] seek[] in [their] trade disparagement claim.”¹⁶⁸⁶

The court next reached a mixed result while addressing the counterclaim defendant’s motion to dismiss the counterclaim plaintiffs’ defamation per se claim, which also rested on the counterclaim defendant’s accusations of counterfeiting and infringement. Although concluding that a particular press release was subject to an “innocent construction” rendering it

¹⁶⁸⁰ See *Maui Jim, Inc. v. SmartBuy Guru Enters.*, 386 F. Supp. 3d 926 (N.D. Ill. 2019).

¹⁶⁸¹ *Id.* at 938.

¹⁶⁸² *Id.* at 939 (quoting *Avery v. State Farm Mut. Auto. Ins. Co.*, 835 N.E.2d 801, 854 (Ill. 2005)).

¹⁶⁸³ *Id.* (quoting *Specht v. Google, Inc.*, 660 F. Supp. 2d 858, 866 (N.D. Ill. 2009)).

¹⁶⁸⁴ *Id.*

¹⁶⁸⁵ *Id.* at 940.

¹⁶⁸⁶ *Id.*

nonactionable,¹⁶⁸⁷ the court otherwise declined to dismiss the averments that the counterclaim defendant had reached out to the counterclaim plaintiffs' customers and potential customers to advise them (falsely) that sunglasses sold by the counterclaim plaintiffs and bearing the counterclaim defendants' marks were "fake," "not authentic," or "not genuine."¹⁶⁸⁸ According to the court, the counterclaim plaintiffs had sufficiently alleged "who made the defamatory statements, how they were published, and the substance of those statements with enough specificity to provide notice of its claim."¹⁶⁸⁹ "Furthermore," it found, "[the counterclaim plaintiffs] allegations tie the defamatory statements into categories of defamation *per se*, namely words that impute lack of integrity in employment duties or that prejudice a person in his or her profession."¹⁶⁹⁰ Because the counterclaim plaintiffs were entitled to the benefit of all reasonable inferences at the pleadings stage, the motion to dismiss proved misplaced.

(B) Massachusetts

The extent to which unfair competition taking place outside a state can create liability under that state's laws is sometimes treated as a question of constitutional law, but a Massachusetts federal district court chose to resolve it from a purely statutory perspective.¹⁶⁹¹ The statute in question recognized a cause of action against "[u]nfair methods of competition and unfair or deceptive acts or practices in the conduct of any trade or commerce,"¹⁶⁹² but only with respect to conduct "occurr[ing] primarily and

¹⁶⁸⁷ The final paragraph of the press release—the counterclaim plaintiffs did not challenge the remainder of that document as defamatory—recited:

"Companies that utilize these types of disingenuous and misleading sales practices undermine the integrity of [our] brand and the quality and technology it has come to represent," said [the counterclaim defendant's] Vice President, Global Marketing. "This lawsuit was filed to protect our brand and the inherent value of its earned reputation, as well as our customers and our authorized retailers. We simply cannot allow our brand to be harmed by the sale of counterfeit or non-genuine . . . products that do not live up to our—and most importantly, our customers'—expectations."

Id. at 942. In dismissing the counterclaim plaintiffs' cause of action as to the press release, the court held, "[w]hen the press release is 'read as a whole and the words given their natural and obvious meaning,' the statements in the fifth paragraph refer to [the counterclaim defendant's] lawsuit and its allegations against [the counterclaim plaintiffs], instead of a defamatory attack that can be separated from the bulk of the press release." *Id.* at 943 (quoting *Tuite v. Corbitt*, 866 N.E.2d 114, 121 (Ill. 2006)).

¹⁶⁸⁸ *Id.* at 941.

¹⁶⁸⁹ *Id.* at 942.

¹⁶⁹⁰ *Id.*

¹⁶⁹¹ See *Smartling, Inc. v. Skawa Innovation Ltd.*, 358 F. Supp. 3d 124 (D. Mass. 2019).

¹⁶⁹² Mass. Gen. Laws ch. 93A, § 2(a) (West 2019).

substantially within the commonwealth.”¹⁶⁹³ Treating this qualifying language as an affirmative defense, the court found that the defendant had successfully established the defense through an application of a three-part test. Specifically: (1) the defendant was located in Hungary and had undertaken its alleged infringement from there;¹⁶⁹⁴ (2) the only customer of the defendant located in Massachusetts was “an experienced, professional purchaser . . . with substantial relationships with both [parties]” and therefore unlikely to confuse the two;¹⁶⁹⁵ and (3) because the plaintiff itself was not located in Massachusetts, it could not claim a loss there.¹⁶⁹⁶ “In sum,” the court held, “[the defendant] has met its burden in showing that the alleged misconduct did not occur primarily and substantially in the Commonwealth of Massachusetts.”¹⁶⁹⁷

(C) *Nebraska*

In an action for trade name infringement under state law, the Supreme Court of Nebraska easily sidestepped an innovative, but ultimately doomed, argument raised by a defendant found liable for that tort after a bench trial.¹⁶⁹⁸ The defendant was incorporated under the DENALI CUSTOM BUILDERS, INC. name, the use of which the plaintiff challenged based on its prior use and registration of the DENALI CONSTRUCTION and DENALI HOMES trade names for competitive building services. According to the defendant, its use of DENALI CUSTOM BUILDERS, INC. was nonactionable because, rather than qualifying as a *trade name* under state law, the defendant used it as its *corporate name*; therefore, the defendant argued, it could not possibly be liable for trade name infringement, regardless of the likely confusion between the parties’ respective uses. The court rejected that argument, concluding from the trial record that “the evidence showed that [the defendant] did not limit itself to its legal corporate name: [the defendant] also held itself out to be ‘Denali Custom Builders.’”¹⁶⁹⁹ The finding of infringement therefore stood because “‘Denali Custom Builders’ is a trade name: It is a name under which [the defendant] transacted business, and it is not [the defendant’s] true name.”¹⁷⁰⁰

¹⁶⁹³ *Id.* § 11.

¹⁶⁹⁴ *Smartling*, 358 F. Supp. 3d at 151-52.

¹⁶⁹⁵ *Id.* at 152.

¹⁶⁹⁶ *Id.* at 153.

¹⁶⁹⁷ *Id.*

¹⁶⁹⁸ See *Denali Real Estate, LLC v. Denali Custom Builders, Inc.*, 926 N.W.2d 610 (Neb. 2019).

¹⁶⁹⁹ *Id.* at 624.

¹⁷⁰⁰ *Id.*

(D) New York

Several opinions contained reminders of the differing tests for unfair competition under the Lanham Act, on the one hand, and New York common law, on the other hand. Although its restatement of the law ultimately did not play a role in its disposition of the claims before it, one court explained:

“[U]nlike its federal counterpart, a viable common law claim for unfair competition requires an additional showing of bad faith.” Therefore, to prevail on a claim for unfair competition under New York common law, the plaintiffs must combine their “evidence supporting liability under the Lanham Act with additional evidence demonstrating that defendants acted in bad faith.”¹⁷⁰¹

“But,” the court added, “under New York law, the use of a counterfeit mark establishes a presumption of bad faith.”¹⁷⁰²

That was not the only scenario recognized as triggering a presumption of bad faith¹⁷⁰³. On the contrary, one court held while denying a motion to dismiss a common-law cause of action for unfair competition that “[i]n trademark cases, where ‘the defendant is aware of the existence of the plaintiff’s mark’ and uses it in violation of unfair competition law, courts infer bad faith.”¹⁷⁰⁴ “To that end,” the court observed while holding the plaintiffs had pleaded their case in sufficient detail to make it past the pleadings stage of the action “when the junior user has prior knowledge of the senior’s mark and the marks are so close as to infer copying’ courts find the defendant has acted in bad faith.”¹⁷⁰⁵ That result was particularly appropriate in the case at hand because “a common sense comparison of the parties’ respective marks makes the inference of intentional copying virtually inescapable.”¹⁷⁰⁶

¹⁷⁰¹ *Gym Door Repairs, Inc. v. Young Equip. Sales, Inc.*, 331 F. Supp. 3d 221, 250 (S.D.N.Y.) (quoting *Lorillard Tobacco Co. v. Jamelis Grocery, Inc.*, 378 F. Supp. 2d 448, 456 (S.D.N.Y. 2005)), *reconsideration denied*, No. 15-CV-4244 (JGK), 2018 WL 5650004 (S.D.N.Y. Oct. 30, 2018).

¹⁷⁰² *Id.*

¹⁷⁰³ *See, e.g., Drone Racing League, Inc. v. DR1, LLC*, 129 U.S.P.Q.2d 1083, 1087-88 (S.D.N.Y. 2018) (similarly denying motion to dismiss on ground that “[i]n determining a defendant’s intent, actual or constructive knowledge of the prior user’s mark or dress may indicate bad faith,’ but not necessarily” (quoting *Paddington Corp. v. Attiki Imps. & Distribs., Inc.*, 996 F.2d 577, 586 (2d Cir. 1993)).

¹⁷⁰⁴ *WM Int’l, Inc. v. 99 Ranch Mkt. #601*, 329 F.R.D. 491, 499 (E.D.N.Y. 2019) (quoting *Pearson Educ., Inc. v. Kumar*, 721 F. Supp. 2d 166, 191 (S.D.N.Y. 2010)).

¹⁷⁰⁵ *Id.* (quoting *Peek & Cloppenburg KG v. Revue, LLC*, No. 11 Civ. 5967(DAB), 2012 WL 4470556, at *6 (S.D.N.Y. Sept. 19, 2012)).

¹⁷⁰⁶ *Id.* at 500.

Other courts reached actual findings of bad faith, whether through an application of those presumptions¹⁷⁰⁷ or for other reasons. For example, in one case producing such a determination, the defendant, a former licensee of the plaintiff, had breached the license and then failed to discontinue use of the marks covered by the license on a post-termination basis.¹⁷⁰⁸ According to the court, “in light of [the defendant’s] continued use of the [licensed mark] in ways plainly not authorized by the [license], there can be no doubt that [the defendant] acted in bad faith and that the [plaintiff] is therefore entitled to summary judgment as to liability on [its cause of action for unfair competition].”¹⁷⁰⁹

A different court also reached an actual finding of bad faith for purposes of the common-law unfair competition claim before it.¹⁷¹⁰ The primary basis of that finding was a false claim of priority by the counterclaim defendants, which they repeatedly advanced without substantiation. But that was not the extent of their misconduct, for the court also cited “ample evidence” that the counterclaim defendants included “a web of companies . . . created to evade scrutiny,” that one had been the recipient of judicial sanctions and that they had known of the counterclaim plaintiffs’ claimed rights before undertaking their allegedly unlawful conduct.¹⁷¹¹ Thus, although the counterclaim plaintiffs’ motion for summary judgment failed because of conflicting evidence over whether the counterclaim defendants’ had created a likelihood of confusion, their satisfaction of the bad-faith intent prong of the cause of action was beyond material dispute.¹⁷¹²

In contrast, however, one court declined to reach the required finding of bad faith, at least as a matter of law.¹⁷¹³ The parties in the case leading to that result manufactured competing bottles, which the plaintiff maintained were confusingly similar. When a jury delivered a defense verdict, the plaintiff challenged that outcome by pointing to “significant evidence” that, when receiving orders referencing the plaintiff’s word mark, the defendant’s employees sometimes shipped the defendant’s bottles without informing the customers in question they were doing so. At the same time, however, the defendant’s employees also testified that they

¹⁷⁰⁷ See *Spin Master Ltd. v. Alan Yuan’s Store*, 325 F. Supp. 3d 413, 422 (S.D.N.Y. 2018) (“Under New York law, a presumption of bad faith attaches to the use of a counterfeit mark.”).

¹⁷⁰⁸ See *City of New York v. Tavern on the Green Int’l LLC*, 351 F. Supp. 3d 680 (S.D.N.Y. 2018).

¹⁷⁰⁹ *Id.* at 967.

¹⁷¹⁰ See *A.V.E.L.A., Inc. v. Estate of Marilyn Monroe, LLC*, 364 F. Supp. 3d 291 (S.D.N.Y. 2019).

¹⁷¹¹ *Id.* at 311.

¹⁷¹² *Id.* at 311-12.

¹⁷¹³ See *Can’t Live Without It, LLC v. ETS Express, Inc.*, 373 F. Supp. 3d 434 (S.D.N.Y. 2018).

understood the customers to be asking for the defendant's bottles even when using the plaintiff's word mark; one employee even indicated that some repeat customers objected to being corrected on the issue. Under these circumstances, and especially because the defendant's labeling of its own goods would immediately call customers' attention to mistaken purchasing decisions, the court found that "a reasonable jury could find that [the defendant's] salespeople would not, and did not, engage in a scheme to palm off [the defendant's bottles] for [the plaintiff's], since it could so easily be detected."¹⁷¹⁴ It then rejected the plaintiff's reliance on e-mails "arguably suggest[ing]" the defendant's bottle was a version of the plaintiff's, holding that a reasonable jury "could easily believe that these emails were shorthand attempts to tell the customer that the [parties'] [b]ottles are similar in shape and function, not to falsely suggest any formal relationship between them."¹⁷¹⁵

Other opinions addressing the idiosyncrasies of New York law focused on the requirements for liability under Sections 349 and 350 of New York's General Business Law,¹⁷¹⁶ with some plaintiffs coming out on the losing end of things.¹⁷¹⁷ One court entertaining cross-motions for summary judgment held:

[T]o prove a violation of Section 349, the [plaintiff] must . . . establish "specific and substantial injury to the public interest over and above the ordinary trademark infringement. . . ." Likewise, to prevail on its General Business Law Section 350 claim, the [plaintiff] must prove harm to the public interest.¹⁷¹⁸

Although finding the plaintiff entitled to prevail as a matter of law on its federal infringement and unfair competition claim, the court declined to reach the same conclusion where Sections 349 and 350 were concerned, noting in particular with respect to the latter that "the [plaintiff] has not explained how the general public interest—as opposed to the [plaintiff's] private economic interest as a market participant—was harmed by [the defendant's] conduct."¹⁷¹⁹

Not all interpretations of the state statutes necessarily disadvantaged the plaintiffs invoking them, though. For example,

¹⁷¹⁴ *Id.* at 438.

¹⁷¹⁵ *Id.* at 439.

¹⁷¹⁶ N.Y. Gen. Bus. Law §§ 349, 350 (McKinney 2013).

¹⁷¹⁷ *See, e.g.,* Drone Racing League, Inc. v. DR1, LLC, 129 U.S.P.Q.2d 1083, 1089 (S.D.N.Y. 2018) (holding, in dispute between drone racing leagues, that allegedly false statements in presentation to potential sponsor did not qualify as required consumer-oriented conduct).

¹⁷¹⁸ *City of N.Y. v. Tavern on the Green Int'l LLC*, 351 F. Supp. 3d 680, 697 (S.D.N.Y. 2018) (quoting *Perfect Pearl Co. v. Majestic Pearl & Stone, Inc.*, 887 F. Supp. 2d 519, 543 (S.D.N.Y. 2012)).

¹⁷¹⁹ *Id.*

in declining to dismiss a claim under Section 349, one court adopted a rather lenient view of the requirement that the defendants' conduct adversely affect the public interest.¹⁷²⁰ In particular, it deemed sufficient the averment in the plaintiff's complaint that the defendants' alleged false advertising "actually deceived or had the tendency to deceive a substantial segment of the potential customers for Defendants' products, and to influence such customers' purchasing decisions."¹⁷²¹ Having reached that conclusion, it declined to dismiss that cause of action.

Likewise, another court reached an actual finding of liability under Section 349 in a case in which the defendant had falsely advertised the sugar content of its drinkable children's yogurt.¹⁷²² Although the defendant argued the plaintiff's proffered evidence and testimony were insufficiently consumer-focused to sustain a claim under the statute, the court held otherwise:

While also establishing a competitive injury, [the plaintiff] has demonstrated that [the false claim in the defendant's] advertisements harm consumers as well, because it misleads parents about the sugar content of a product intended for their children. As one court has explained, the public "has a strong interest in receiving accurate information, especially when it comes to products marketed specifically for children."¹⁷²³

(E) South Carolina

In a case in which the plaintiff asserted claims for trade dress infringement under both the Lanham Act and South Carolina Unfair Trade Practices Act (SCUTPA),¹⁷²⁴ the court confirmed that the requirements under both were the same—with one exception.¹⁷²⁵ The exception, the court explained, was that state law required a demonstration that the defendant's conduct had an impact on the public.¹⁷²⁶ As it turned out, however, that extra requirement was easily satisfied by the plaintiff's showing of potential for repetition of the defendant's conduct. As under federal

¹⁷²⁰ See *Wolo Mfg. Corp. v. ABC Corp.*, 349 F. Supp. 3d 176 (E.D.N.Y. 2018).

¹⁷²¹ *Id.* at 210.

¹⁷²² See *Danone, US, LLC v. Chobani, LLC*, 362 F. Supp. 3d 109 (S.D.N.Y. 2019).

¹⁷²³ *Id.* at 123 (quoting *CJ Prods. LLC v. Snuggly Plushez LLC*, 809 F. Supp. 2d 127, 149 (E.D.N.Y. 2011)).

¹⁷²⁴ S.C. Code Ann. § 39-5-140 (West 1985).

¹⁷²⁵ See *SafeRack, LLC v. Bullard Co.*, 350 F. Supp. 3d 438 (D.S.C. 2018), *report and recommendation adopted*, No. 2:17-cv-1613-RMG, 2019 WL 460699 (D.S.C. Feb. 5, 2019).

¹⁷²⁶ *Id.* at 456.

law, the plaintiff therefore was entitled to prevail as a matter of law on its claims against the defendant under the SCUTPA.¹⁷²⁷

(F) South Dakota

South Dakota law permits a plaintiff demonstrating deceptive acts or practices by a defendant to recover the “actual damages” it has suffered “as a result of” the defendant’s misconduct.¹⁷²⁸ Following a full trial on allegations that the defendants had unlawfully misrepresented their goods as “officially licensed,” a jury awarded damages to the prevailing plaintiff in an application of that standard, leading the defendants to challenge the award as lacking support in the record.¹⁷²⁹ In affirming, the Eighth Circuit pointed to evidence in the trial record that a manager at a local retailer had inquired about the authenticity of the defendants’ goods but only after the retailer had sold them for an entire season. That contact, the court held, could reasonably have led the jury to infer that the defendants had made sales to the retailer at the plaintiff’s expense.¹⁷³⁰

(G) Virginia

The Virginia Consumer Protection Act “promote[s] fair and ethical standards of dealings between suppliers and the consuming public.”¹⁷³¹ As a federal district court sitting in the commonwealth confirmed, however, the Act does not ordinarily provide protection for businesses engaged in purely commercial disputes.¹⁷³² The court reached that conclusion in an action in which the operator of a substance abuse treatment center accused a marketing company of having engaged in a variety of practices aimed at diverting business from the Virginia-based plaintiff to out-of-state competitors. Even assuming the defendant itself was not a competitor, the court still held that the plaintiff had failed to aver a critical element of a prima facie case under the Act, namely, its own reliance on the defendant’s misrepresentations.¹⁷³³

The court did, however, allow a considerably more imaginative cause of action to move forward, namely, one based on a statute criminalizing the intentional removal, alteration, destruction, or obliteration of another’s “mark on or from any article or device, in

¹⁷²⁷ *Id.*

¹⁷²⁸ S.D. Codified Laws § 37-24-31 (West 2004).

¹⁷²⁹ *See Sturgis Motorcycle Rally, Inc. v. Rushmore Photo & Gifts, Inc.*, 908 F.3d 313, 320-21 (8th Cir. 2018), *on remand*, 129 U.S.P.Q.2d 1392 (D.S.D. 2019).

¹⁷³⁰ *Id.* at 341.

¹⁷³¹ Va. Code Ann. § 59.1-197 (2019).

¹⁷³² *See BHR Recovery Cmtys., Inc. v. Top Seek, LLC*, 355 F. Supp. 3d 416 (E.D. Va. 2018).

¹⁷³³ *Id.* at 424.

order to secrete its identification with intent to defraud.”¹⁷³⁴ Noting the existence of a private cause of action for violations of the statute,¹⁷³⁵ the court initially held that “[t]he plain meanings of the words ‘article’ and ‘device’ signal that the statute addresses physically removing a trademark.”¹⁷³⁶ Nevertheless, it ultimately concluded that, in the absence of authority to the contrary, “[the plaintiff] adequately pleads the elements in the statute by claiming that [the defendant] intentionally changed [the plaintiff’s] trademark by altering the phone number associated with it.”¹⁷³⁷

f. Secondary Liability

Trademark law generally contemplates two theories under which a court can impose secondary liability on a defendant not directly participating in violations of a plaintiff’s rights, namely, contributory unfair competition and vicarious liability. Courts do not often tackle both theories in the same proceeding, but the First Circuit did so in a dispute between a current member and a former member of the rock band Boston.¹⁷³⁸ The appeal in that case presented the question of whether the former member properly had defeated on summary judgment the current member’s claims that the former member was liable for the contributory infringement of the BOSTON mark by a third party, as well as that he was vicariously liable for the third party’s conduct. The salient language of a prior settlement agreement between the parties allowed the defendant to promote himself as “formerly of Boston,” but it otherwise prohibited him from using the mark. The gravamen of the plaintiff’s complaint was that the defendant had encouraged the third party to refer to him as an “original founding member” or “Lead Guitarist Rock Legend from the Band BOSTON.”¹⁷³⁹ In response to the defendant’s motion for summary judgment, the plaintiff pointed to the defendant’s claim that he “made sure that all venues, managers, and other[s] involved referred to [him] . . . using the truthful and accurate descriptive designations of formerly of BOSTON or as an original member of BOSTON”¹⁷⁴⁰ and argued that a reasonable factfinder could infer that the defendant had authorized the offending uses. Ultimately, however, “there was no evidence in the record from which the district court could have drawn the inference to which [the plaintiff] claims that he was

¹⁷³⁴ Va. Code Ann. § 18.2-214 (2019).

¹⁷³⁵ *Id.* § 59.1-68.3.

¹⁷³⁶ *BHR Recovery Cmtys.*, 355 F. Supp. 3d at 427.

¹⁷³⁷ *Id.*

¹⁷³⁸ *See* *Scholz v. Goudreau*, 901 F.3d 37 (1st Cir. 2018).

¹⁷³⁹ *Id.* at 43.

¹⁷⁴⁰ *Id.* (alterations in original).

entitled,”¹⁷⁴¹ which meant the defendant properly had prevailed as a matter of law.

Other courts hearing claims of secondary liability did so under one theory or the other.¹⁷⁴² Following the Second Circuit’s adoption of a strict test under the former theory in *Tiffany (NJ) Inc. v. eBay, Inc.*,¹⁷⁴³ reported findings of contributory infringement for the operators of online marketplaces have been rare, but an exception to that general rule arose from a case before a Wisconsin federal district court.¹⁷⁴⁴ The summary judgment record in that proceeding established that the lead defendant operated an online marketplace on which graphic artists could upload various designs; consumers could then choose to have the lead defendant affix those designs to various goods. In response to the plaintiffs’ motion for summary judgment, the lead defendant argued it was entitled to an application of the *Tiffany* test for contributory infringement, under which an online vendor can escape liability unless a plaintiff can prove it allowed a sale to move forward with actual knowledge that the good in question bore an infringing or counterfeit mark. Although concluding the lead defendant was directly liable for infringing the plaintiff’s mark, it held the plaintiff had satisfied the requirements for contributory infringement as well because it had adduced undisputed evidence and testimony that the lead defendant: (1) “actively induces infringement . . . by encouraging users to go to its website and create and order infringing goods (which, of course, [the lead defendant] itself prints)”,¹⁷⁴⁵ and (2) “knew it did not have a license to use the [plaintiff’s] Marks, and only willful blindness could keep it from realizing that it was nevertheless selling goods bearing those marks.”¹⁷⁴⁶

On the vicarious liability front, one lead defendant unsuccessfully responded to a motion for summary judgment by arguing it had merely authorized another defendant to locate suitable licensees for a mark found by the court to violate the

¹⁷⁴¹ *Id.* at 45.

¹⁷⁴² *See, e.g.,* *Belmora, LLC v. Bayer Consumer Care AG*, 338 F. Supp. 3d 477, 486 (E.D. Va. 2018) (granting motion for summary judgment of nonliability for contributory infringement because “[the plaintiff] has not presented any evidence that [the defendants] [have] offered [goods bearing the disputed mark] for sale in the U.S., that it has induced others to sell the product in the U.S., or that it has continued to supply the product to a party with knowledge or reason to know that party was selling it in the U.S.”); *appeal docketed*, No. 18-2183 (4th Cir. Oct. 9, 2018); *Sprint Sols., Inc. v. Lafayette*, 127 U.S.P.Q.2d 1256, 1268-69 (W.D. Tenn. 2018) (granting unopposed motion for default judgment of contributory infringement).

¹⁷⁴³ 600 F.3d 93 (2d Cir. 2010).

¹⁷⁴⁴ *See H-D U.S.A., LLC v. SunFrog, LLC*, 311 F. Supp. 3d 1000 (E.D. Wis.), *appeal dismissed*, No. 18-2073, 2018 WL 6039900 (7th Cir. July 19, 2018).

¹⁷⁴⁵ *Id.* at 1040.

¹⁷⁴⁶ *Id.* at 1041.

plaintiff's rights.¹⁷⁴⁷ According to the summary judgment record, “[the other defendant’s] infringing acts were within the scope of its authority as [the lead defendant’s] agent, and were conducted with [the lead defendant’s] knowledge.”¹⁷⁴⁸ That, the court held, was a sufficient basis to hold the lead defendant vicariously liable as a matter of law for the acts of the other defendant and the licensees the other defendant had recruited.

g. Individual Liability

As always, plaintiffs’ attempts to hold individual defendants liable along with those defendants’ employers reached mixed results. On the plaintiffs’ side of the ledger, one prevailing plaintiff successfully pursued a claim of individual liability against the principal of at least one of several corporate defendants found liable for counterfeiting as a matter of law.¹⁷⁴⁹ In entering summary judgment against the individual defendant as well, the court adopted the time-honored rule that “[c]orporate officers are ‘personally liable for [a] corporation’s . . . trademark infringements when they are a “moving, active conscious force” behind the corporation’s infringement.”¹⁷⁵⁰ It then found that test satisfied based on the plaintiff’s undisputed showings that the individual defendant: (1) owned one of the corporate defendants; (2) wrote the online descriptions of the goods sold by that company; and (3) instructed a subordinate which products to list on, or to remove from, the company’s website.¹⁷⁵¹ Those showings led to the court’s ultimate conclusion that “Plaintiff has proven there is no disputed fact that [the individual defendant’s] involvement in the allegedly infringing activity is sufficient to find him personally liable for the activity.”¹⁷⁵²

Another successful claim of individual liability came in a case in which the defendants were a corporation, a limited liability company, and the single individual who controlled them both.¹⁷⁵³ Following a bench trial in which the companies’ infringement was clearly established, the court determined the individual defendant was similarly situated. It tied up the relevant test by observing that

¹⁷⁴⁷ See *Gianni Versace, S.p.A. v. Versace 19.69 Abbigliamento Sportivo SRL*, 328 F. Supp. 3d 1007 (N.D. Cal. 2018), *appeal dismissed*, No. 19-15188, 2019 WL 2005744 (9th Cir. Apr. 17, 2019).

¹⁷⁴⁸ *Id.* at 1022.

¹⁷⁴⁹ See *Daimler AG v. A-Z Wheels LLC*, 334 F. Supp. 3d 1087 (S.D. Cal. 2018).

¹⁷⁵⁰ *Id.* at 1106 (second and third alterations in original) (quoting *Novell, Inc. v. Unicom Sales, Inc.*, No. C-03-2785 MMC, 2004 WL 1839117, at *17 (N.D. Cal. Aug. 17, 2004)).

¹⁷⁵¹ *Id.*

¹⁷⁵² *Id.*

¹⁷⁵³ See *Safeway Transit LLC v. Disc. Party Bus, Inc.*, 334 F. Supp. 3d 995 (D. Minn. 2018), *appeal docketed*, No. 18-2990 (8th Cir. Sept. 17, 2018).

“[a] corporate officer is personally liable for the corporation’s trademark infringement if the officer participates in that infringement.”¹⁷⁵⁴ Then, in an application of that standard, it found that “[the individual defendant] is and has always been the sole owner, manager, and employee of [the lead defendant], and he signed [a] contract with [a third-party marketing company] that led to the infringing content. Thus, the Court finds that he is personally liable for [the lead defendant’s] infringement.”¹⁷⁵⁵

A third finding of individual liability occurred in the context of a challenge to a jury verdict holding two individual defendants jointly and severally liable for infringement along with the lead corporate defendant.¹⁷⁵⁶ In a post-trial challenge to that finding, the defendants requested the court to apportion the jury’s award of actual damages between the parties, but the court declined to do so. Instead, it held that “[c]orporate officers are ‘personally liable for [a] corporation’s . . . trademark infringements when they are a moving, active conscious force behind the corporation’s infringement.’”¹⁷⁵⁷ Reviewing the trial record, it identified testimony demonstrating the individual defendants were just such a force.¹⁷⁵⁸ “Moreover,” and in any case, “neither party suggested the inclusion of any apportionment on the verdict form, and both parties consented to and signed off on this decision before the end of trial.”¹⁷⁵⁹

Some claims of individual liability failed. When a group of defendants registered (and then reregistered) a series of domain names incorporating the plaintiff’s marks, and then used the domain names to direct online traffic to websites at which the defendants provided services directly competitive to those of the plaintiff, the plaintiff filed a suit asserting cybersquatting and unfair competition.¹⁷⁶⁰ Having named her employer as a corporate defendant, the plaintiff additionally targeted an individual in her capacity as the corporate defendant’s general manager. At the close of discovery, however, the individual defendant successfully moved the court for summary judgment of nonliability. In granting the motion, the court noted the absence of any record evidence that the individual defendant owned the account holding the disputed domain names or even that she had access to it. “In addition,” the court found, “she was not involved in the redirection of the domain

¹⁷⁵⁴ *Id.* at 1007 (quoting *Microsoft Corp. v. Ion Techs. Corp.*, Civ. No. 01-1769 (JNE/JGL), 2003 WL 21356084, at *5 (D. Minn. May 30, 2003)).

¹⁷⁵⁵ *Id.*

¹⁷⁵⁶ *See* *Talent Mobile Dev., Inc. v. Headios Grp.*, 382 F. Supp. 3d 953 (C.D. Cal. 2019), *appeal docketed*, No. 19-55258 (9th Cir. Mar. 5, 2019).

¹⁷⁵⁷ *Id.* at 962 (second and third alterations in original) (quoting *Daimler AG v. A-Z Wheels LLC*, 334 F. Supp. 3d 1087, 1106 (S.D. Cal. 2018)).

¹⁷⁵⁸ *Id.* at 962-63.

¹⁷⁵⁹ *Id.* at 963.

¹⁷⁶⁰ *See* *ZIP No. 314, LLC v. ILM Capital, LLC*, 335 F. Supp. 3d 1242 (S.D. Ala. 2018).

names, and she no longer has any relationship, affiliation, or association with [her employer] (or any of the Defendants in this action).¹⁷⁶¹ Although the plaintiff claimed in response to the defendant's motion that she had provided the individual actually responsible for the registration and the reregistration of the domain names with updates on the plaintiff's promotional activities, that claim failed to create a factual dispute concerning her individual liability.¹⁷⁶²

Likewise, following a full trial on the merits, a plaintiff successfully convinced a jury to hold a corporate defendant liable for infringement, but it failed to do the same with respect to an individual defendant.¹⁷⁶³ The court declined the plaintiff's invitation to overturn the jury's verdict on that issue, concluding from the trial record that:

[T]he law does not require that an officer/individual be liable for every instance of infringement by a corporation. It was the jury's job to weigh the facts and law for each defendant individually. Here, the jury heard from [the individual defendant] personally, and in weighing his testimony together with all the other information of record, the jury could reasonably conclude that the corporate decisions involved were the product of group decisions within [the corporate defendant], and that [the individual defendant's] personal level of involvement and his personal intentions weighed against a finding of personal liability.¹⁷⁶⁴

Finally, some courts held the issue of individual liability inappropriately resolved as a matter of law at the pleadings stage.¹⁷⁶⁵ They included a New York intermediate appellate court in a suit between competing providers of orthodontic services.¹⁷⁶⁶ The plaintiff's complaint named a professional services corporation and two individuals as defendants, in response to which the two individuals moved the trial court to dismiss from the case. The trial court declined to do so, and that disposition survived their subsequent appeal. The appellate court held:

¹⁷⁶¹ *Id.* at 1272.

¹⁷⁶² *Id.*

¹⁷⁶³ *See* *Evoqua Water Techs. LLC v. M.W. Watermark, LLC*, 128 U.S.P.Q.2d 1775 (W.D. Mich. 2018).

¹⁷⁶⁴ *Id.* at 1782.

¹⁷⁶⁵ *See, e.g.,* *Helpful Hound, L.L.C. v. New Orleans Bldg. Corp.*, 333 F. Supp. 3d 593, 603 (E.D. La. 2018) (denying motion to dismiss with explanation that "if a defendant's actions breached a duty he personally owed to a plaintiff and thereby caused injury, the defendant is not immune from liability merely because he acted as a member or manager of a limited liability company").

¹⁷⁶⁶ *See* *Emanuel Mizrahi, DDS, P.C. v. Angela Andretta, DMD, P.C.*, 97 N.Y.S.3d 273 (N.Y. App. Div. 2019).

[C]ontrary to the defendants' arguments, the complaint did not purport to hold the individual defendants liable for the corporate defendant's allegedly wrongful conduct by virtue of their status as its principals. Rather, the complaint sought to hold them individually liable for committing the alleged wrongs, and as such, dismissal was not required simply because the plaintiff failed to plead facts sufficient to pierce the corporate veil.¹⁷⁶⁷

h. Liability for Procurement of Registrations Through False or Fraudulent Representations

Section 38 of the Act provides that “[a]ny person who shall procure registration in the Patent and Trademark Office of a mark by a false or fraudulent declaration or representation, oral or in writing, or by any false means, shall be liable in a civil action by any person injured thereby for any damages sustained in consequence thereof”;¹⁷⁶⁸ moreover, similar causes of action are recognized by the trademark acts of many states. Despite the availability of these mechanisms, recovery under them is the exception, rather than the rule. This is due in part to the difficulty of proving fraud on the USPTO in the first instance, but the inability of plaintiffs asserting causes of action under Section 38 and its state-law counterparts to prove damages arising from that fraud also plays a role.

That issue was apparent in two opinions arising from the same dispute.¹⁷⁶⁹ The plaintiff averred that the defendant had procured a registration of its mark by including in its use-based application two false or fraudulent claims, namely, that: (1) the defendant's mark had been used in commerce as of the application's filing date; and (2) the defendant enjoyed the exclusive right to use its mark despite the existence of allegedly confusingly similar marks owned by third parties. The court's first opinion dismissed the plaintiff's Section 38 cause of action for failure to state a claim because the plaintiff's only averments of financial damage consisted of the attorneys' fees it had incurred responding to the defendant's assertion of superior rights and the vague complaint that the defendant's registration had stifled the plaintiff's ability to use its own mark freely.¹⁷⁷⁰ In contrast, the second opinion sustained the sufficiency of the plaintiff's amended allegation of damage in the form of increased marketing expenses and diverted employee time necessary to counteract the effect of the defendant's conduct in the registration

¹⁷⁶⁷ *Id.* at 276.

¹⁷⁶⁸ 15 U.S.C. § 1120 (2018).

¹⁷⁶⁹ See *San Diego Cty. Credit Union v. Citizens Equity First Credit Union*, 344 F. Supp. 3d 1147 (S.D. Cal. 2018) (“*San Diego Cty. Credit Union I*”), later proceedings, 360 F. Supp. 3d 1039 (S.D. Cal. 2019) (“*San Diego Cty. Credit Union II*”).

¹⁷⁷⁰ *San Diego Cty. Credit Union I*, 344 F. Supp. 3d at 1162.

process. Although the defendant argued that a six-year gap between the issuance of the registration and the plaintiff's complaint precluded that theory of recovery, the court concluded that proximate causation was a question of fact inappropriately resolved at the pleadings stage; likewise, the court rejected the defendant's claim that, because the defendant was entitled to assert common-law rights to its mark, the registration status of the mark was irrelevant as similarly premature.¹⁷⁷¹

2. Defenses

a. Legal Defenses

i. Abandonment

Section 45 of the Lanham Act identifies two circumstances under which a mark owner can abandon its rights:

A mark shall be deemed to be “abandoned” if either of the following occurs:

(1) When its use has been discontinued with intent not to resume such use. Intent not to resume may be inferred from circumstances. Nonuse for 3 consecutive years shall be prima facie evidence of abandonment. “Use” of a mark means the bona fide use of such mark made in the ordinary course of trade, and not made merely to reserve a right in a mark.

(2) When any course of conduct of the owner, including acts of omission as well as commission, causes the mark to become the generic name for the goods or services on or in connection with which it is used or otherwise to lose its significance as a mark. Purchaser motivation shall not be a test for determining abandonment under this paragraph.¹⁷⁷²

Both types of abandonment came into play over the course of the past year, with plaintiffs generally prevailing on the issue.

(A) Nonuse

Courts rarely address the issue of abandonment through nonuse at the pleadings stage of cases, but an opinion from a California federal district court did so in a case brought by entertainment behemoth Lucasfilm Ltd. and an affiliate.¹⁷⁷³ The plaintiffs sought to protect the SABACC mark, originally the name for a fictional card game featured in the *Star Wars* franchise of creative works but eventually the subject of an extensive licensing program. In an unsuccessful motion to dismiss the plaintiffs' complaint for failure

¹⁷⁷¹ *San Diego Cty. Credit Union II*, 360 F. Supp. 3d at 1051-52.

¹⁷⁷² 15 U.S.C. § 1127 (2018).

¹⁷⁷³ *See Lucasfilm Ltd. v. Ren Ventures Ltd.*, 126 U.S.P.Q.2d 1515 (N.D. Cal. 2018).

to state a claim, the defendants, although apparently not asserting abandonment as an affirmative defense per se, argued the plaintiffs had failed to allege the continuous use of their mark necessary to maintain priority of rights to it. The court rejected that argument out of hand, holding that:

[W]hether each use is “continuing” is a question of fact that cannot be determined on the pleadings alone. Defendants provide no authority for the proposition that [Plaintiffs are] required to release a new product bearing the “Sabacc” mark *each year* in order to maintain continuous use. It may be sufficient, for example, that the products identified in the complaint remain popular and continue to circulate in commerce years after their unveiling. Accordingly, [Plaintiffs have] alleged enough facts to raise a plausible inference that [they have] established trademark priority through continuing use of the “Sabacc” mark.¹⁷⁷⁴

Whatever the statutory definition of abandonment in Section 45 might contemplate, the Sixth Circuit confirmed it does not mean that a lapsed registration necessarily works a forfeiture of the registrant’s rights.¹⁷⁷⁵ In the appeal before that court, the summary judgment record established that, far from discontinuing the use of its formerly registered mark, the plaintiff maintained a stable of licensees, a circumstance the court considered “the opposite of abandonment.”¹⁷⁷⁶ Moreover, and in any case, the plaintiff had “quickly” pursued a new registration of its mark, thereby “confirming its continuing desire to maintain the trademark.”¹⁷⁷⁷ The district court therefore properly had rejected as a matter of law the defendants’ claim of abandonment.

Other courts similarly confirmed on motions for summary judgment of liability that a finding of abandonment under this theory will not lie in the absence of a discontinuance of use the underlying mark.¹⁷⁷⁸ One did so in a case in which, after acquiring a subsidiary in a corporate transaction, the plaintiff dissolved the subsidiary and failed to maintain registrations owned by the

¹⁷⁷⁴ *Id.* at 1520.

¹⁷⁷⁵ *See Ausable River Trading Post, LLC v. Dovetail Sols., Inc.*, 902 F.3d 567 (6th Cir. 2018).

¹⁷⁷⁶ *Id.* at 572.

¹⁷⁷⁷ *Id.*

¹⁷⁷⁸ *See, e.g., SafeRack, LLC v. Bullard Co.*, 350 F. Supp. 3d 438, 454 (D.S.C. 2018) (concluding on parties’ cross-motions for summary judgment and without extensive discussion of issue that “there is no evidence in the record that [the plaintiff] has abandoned its orange mark as used on its railings, gates, or cages of fall protection equipment”), *report and recommendation adopted*, No. 2:17-cv-1613-RMG, 2019 WL 460699 (D.S.C. Feb. 5, 2019).

subsidiary covering the marks it sought to protect.¹⁷⁷⁹ Citing the Ninth Circuit rule that “[e]ven a single instance of use is sufficient against a claim of abandonment of a mark if such use is made in good faith,”¹⁷⁸⁰ the court held those facts insufficient to create a factual issue regarding the marks’ nonabandonment. Instead, it noted, “Plaintiff proffers ample evidence of its use of the . . . Marks and [the subsidiary’s] history in its promotional materials, bid documents, client presentations, and at booths and conferences.”¹⁷⁸¹ Of equal significance, even had discontinuance occurred, “Defendants have not put forth evidence showing an intent by Plaintiff to completely cease using the . . . Marks.”¹⁷⁸² “Consequently,” the court concluded, “there is no genuine issue of material fact and Defendants’ abandonment defense fails.”¹⁷⁸³

A factual question concerning the ongoing use of a claimed trade dress in the form of the appearance of a website similarly precluded the grant of a defense motion for summary judgment in another case.¹⁷⁸⁴ The defendant argued that the website it allegedly had copied no longer was online and had not been used for more than the three years recognized by Section 45 as prima facie evidence of abandonment. As the court summarized the plaintiff’s response, however, “the infringed trade dress was in use at the time of the alleged infringement, and even if the copied version of its website was not still in use, there remains a ‘great deal of continuity between the websites that [the plaintiff] used before and after’ the launch of the updated website.”¹⁷⁸⁵ The court concluded that the parties’ conflicting positions precluded a finding of abandonment as a matter of law: “Considering the disputes of fact over when [the plaintiff] updated its website and the extent of the continuity between the copied version of the website and subsequent versions, the issue of abandonment turns on triable questions of fact.”¹⁷⁸⁶

Still, however, at least one claim of abandonment through nonuse succeeded, albeit with considerable help from the former owner of the marks in question.¹⁷⁸⁷ Having seen the plaintiffs’ use of three marks in connection with identical services, the defendants

¹⁷⁷⁹ See *AECOM Energy & Constr., Inc. v. Ripley*, 348 F. Supp. 3d 1038 (C.D. Cal. 2018), *reconsideration denied*, No. CV 17-5398-RSWL-SSx, 2019 WL 2610953 (C.D. Cal. Apr. 24, 2019), *appeal docketed*, No. 19-55588 (9th Cir. May 23, 2019).

¹⁷⁸⁰ *Id.* at 1055 (quoting *Carter-Wallace, Inc. v. Procter & Gamble Co.*, 434 F.2d 794, 804 (9th Cir. 1970)).

¹⁷⁸¹ *Id.*

¹⁷⁸² *Id.*

¹⁷⁸³ *Id.*

¹⁷⁸⁴ See *Smartling, Inc. v. Skawa Innovation Ltd.*, 358 F. Supp. 3d 124 (D. Mass. 2019).

¹⁷⁸⁵ *Id.* at 147.

¹⁷⁸⁶ *Id.*

¹⁷⁸⁷ See *Safeway Transit LLC v. Disc. Party Bus, Inc.*, 334 F. Supp. 3d 995 (D. Minn. 2018), *appeal docketed*, No. 18-2990 (8th Cir. Sept. 17, 2018).

discontinued their own use of the marks in 2009. That one of the defendants subsequently filed (successful) applications to register the marks in 2014 did not retroactively resurrect the defendants' rights. To the contrary, the court noted that the defendant registrant had testified at trial that the defendants "ceased use of the three terms in 2009 because [the plaintiffs] began to use them and that he had no intent to resume use even when he registered them as marks in 2014."¹⁷⁸⁸ "Therefore," the court concluded, "[the lead defendant] was not the senior user of the marks during the alleged infringement period because it abandoned any rights it may have had in the three terms as marks no later than 2009."¹⁷⁸⁹ The outcome therefore represents a rare finding of abandonment immediately upon discontinuance.

(B) Loss of Trademark Significance

Although defendants often assert plaintiffs have abandoned their rights through naked licensing, they rarely do so successfully.¹⁷⁹⁰ For example, one failed claim of abandonment under that theory rested on the counterclaim plaintiff's coexistence with another company under a similar name.¹⁷⁹¹ As the court concluded based on the preliminary injunction record assembled by the counterclaim plaintiff, the same individual owned and controlled both companies. Because "[t]he authorized use of a Mark by a related company does not constitute abandonment of the Mark," the counterclaim defendant's claim of abandonment did not gain traction with the court.¹⁷⁹²

Nevertheless, a claim of naked licensing succeeded as a matter of law in a case in which the licensor and its licensee were controlled by the same husband-and-wife team.¹⁷⁹³ The summary judgment record established that the licensor "does not conduct business; has no payroll; has no employees; does no marketing to potential customers or potential dealers; and does not manufacture [the goods sold under the mark]."¹⁷⁹⁴ In addition, and just as bad from the court's perspective:

¹⁷⁸⁸ *Id.* at 1004.

¹⁷⁸⁹ *Id.*

¹⁷⁹⁰ *See, e.g.,* Marco's Franchising, LLC v. Soham, Inc., 365 F. Supp. 3d 891, 895 (N.D. Ohio 2019) (rejecting claim of naked licensing despite absence of written license between franchisor and franchisees).

¹⁷⁹¹ *See* Mayson-Dixon Strategic Consulting, LLC v. Mason-Dixon Polling & Strategic Consulting, Inc., 324 F. Supp. 3d 569 (D. Md. 2018).

¹⁷⁹² *Id.* at 577.

¹⁷⁹³ *See* Gym Door Repairs, Inc. v. Young Equip. Sales, Inc., 331 F. Supp. 3d 221 (S.D.N.Y.), *reconsideration denied*, No. 15-CV-4244 (JGK), 2018 WL 5650004 (S.D.N.Y. Oct. 30, 2018).

¹⁷⁹⁴ *Id.* at 251 (citations omitted).

[The licensor] does not have any contract with [its licensee] setting forth the scope of their relationship and thus plainly does not have any contract with [the licensee] regarding [the licensee's] use of the [claimed] mark. [The licensor] does not control [the licensee's] use of the [licensed] mark[.]. There is also no evidence that [the licensor] monitors [the licensee] to guarantee the quality of the products sold by [the licensee] that bear the . . . trademark. This is a naked license.¹⁷⁹⁵

The close family-based relationship between the licensor and the licensee might have excused the lack of a formal written license,¹⁷⁹⁶ but the licensor apparently failed to play that card. Instead, it relied unsuccessfully on its practice of allowing the sale of goods bearing the mark only through authorized dealers and sending cease and desist letters to, or suing, entities using the mark without authorization. The court found those practices irrelevant to the issue of the licensor's control over the licensee's use of the mark. Especially because "it would not be possible for [the licensor] to monitor [the licensee] because [the licensor] has no employees,"¹⁷⁹⁷ the court found the licensor's abandonment of its rights beyond material dispute.

ii. Descriptive Fair Use

Descriptive fair use, sometimes known as "classic" fair use, by a defendant of either the plaintiff's mark or the words making up that mark may be justified under any of three theories. First, Section 33(b)(4) of the Act recognizes as a defense to the conclusive evidentiary presumptions attaching to an incontestably registered mark that a defendant is using "otherwise than as a mark" a personal name or other words "fairly and in good faith only to describe the [associated] goods or services . . . or their geographic origin."¹⁷⁹⁸ Second, the common law preserves defendants' ability to use personal names and descriptive terms in their primary descriptive sense; consequently, a defendant in an action to protect a registered mark who first satisfies Section 33(b)(4)'s requirements can then fall back on the common law to provide a defense on the merits. Finally, Section 43(c)(3)(A) excludes from liability in a likelihood-of-dilution action "[a]ny fair use, including a . . . descriptive fair use, or facilitation of such fair use, of a famous mark

¹⁷⁹⁵ *Id.* (citations omitted).

¹⁷⁹⁶ *See, e.g.,* Taco Cabana Int'l, Inc. v. Two Pesos, Inc., 932 F.2d 1113, 1121-22 (5th Cir. 1991) (relying on relationship between businesses controlled by two brothers to reject claim of naked license), *aff'd on other grounds*, 505 U.S. 763 (1992).

¹⁷⁹⁷ *Gym Door Repairs*, 331 F. Supp. 3d at 251.

¹⁷⁹⁸ *Id.* § 1115(b)(4).

by another person other than as a designation of source for the person's own goods or services."¹⁷⁹⁹

In entertaining an appeal from a factual finding of descriptive fair use, the Eleventh Circuit held as an initial matter that “[a] defendant is entitled to the fair use defense if it establishes that it used the allegedly infringing term ‘(1) other than as a mark, (2) in a descriptive sense, and (3) in good faith.’”¹⁸⁰⁰ The plaintiff victimized by that finding challenged it under the second of the three prongs of the relevant test. According to that party, the defendant's use of the words “hard candy” in capital letters in conjunction with a particular shade of facial highlighter failed as a matter of law to qualify as a descriptive one. The appellate court disagreed, holding instead that the district court properly had looked to the overall context in which the disputed words appeared, which included its consideration of their subsidiary placement on the rear panel and interior of the defendant's packaging. Moreover:

[The district court] accepted the argument that “hard candy” was used in a descriptive sense because ‘it was used to describe the sheen’ of the makeup shade that the term labeled. [The defendant] introduced evidence that cosmetics companies regularly describe shades with words that are not literal color descriptions, like the other three shades in the [defendant's cosmetic] kit named “Starburst,” “Mimosa,” and “Crushed Pearl.” The district court was attempting to discern how a reasonable consumer of cosmetics would perceive [the defendant's] use of the mark, not relying purely on [the defendant's] subjective intent, contrary to [the plaintiff's] assertion.¹⁸⁰¹

The finding of descriptive fair use therefore stood.

In contrast, other assertions of the defense failed as a matter of law.¹⁸⁰² One did so in a case in which the lead defendant claimed not to use the challenged mark because it merely licensed the mark's use by third parties.¹⁸⁰³ In granting the plaintiff's motion for summary judgment, the court noted that “[the lead defendant] does not present any authority that licensing the use of an infringing mark is not itself ‘use’ of a trademark for purposes of this

¹⁷⁹⁹ *Id.* § 1125(c)(3)(A).

¹⁸⁰⁰ *Hard Candy, LLC v. Anastasia Beverly Hills, Inc.*, 921 F.3d 1343, 1363 (11th Cir. 2019) (quoting *Int'l Stamp Art, Inc. v. U.S. Postal Serv.*, 456 F.3d 1270, 1274 (11th Cir. 2006)).

¹⁸⁰¹ *Id.* at 1364.

¹⁸⁰² *See, e.g., SafeRack, LLC v. Bullard Co.*, 350 F. Supp. 3d 438, 453 (D.S.C. 2018) (rejecting, without extensive discussion of issue, claim of descriptive fair use of orange color in connection with safe access equipment), *report and recommendation adopted*, No. 2:17-cv-1613-RMG, 2019 WL 460699 (D.S.C. Feb. 5, 2019).

¹⁸⁰³ *See Gianni Versace, S.p.A. v. Versace 19.69 Abbigliamento Sportivo SRL*, 328 F. Supp. 3d 1007 (N.D. Cal. 2018), *appeal dismissed*, No. 19-15188, 2019 WL 2005744 (9th Cir. Apr. 17, 2019).

defense.”¹⁸⁰⁴ In any case, “[the lead defendant] also independently used the [infringing] mark[] as part of its branding and promotional efforts. That evidence is sufficient to show that [the lead defendant] attempted to use the [mark] ‘as a symbol to attract public attention.’”¹⁸⁰⁵ That was not the only flaw in the defendants’ invocation of the defense, however: On the contrary, the defendants’ bad faith was apparent in their use of the challenged mark despite the rejection by “numerous Italian court decisions” of their claim that a prior settlement agreement (governed by Italian law) between the parties permitted that use and their failure to comply with “multiple cease-and-desist letters” sent by the plaintiff.¹⁸⁰⁶

A second failed invocation of the descriptive fair use defense came in a case against defendants who provided themed party entertainment services that included appearances of costumed characters undeniably based on characters drawn from the plaintiffs’ Disney, Star Wars, and Marvel entertainment franchises.¹⁸⁰⁷ Having imitated the plaintiffs’ characters in that manner, the defendants claimed the concomitant right to use the plaintiffs’ verbal marks to promote their services. The court found that claim deficient for two reasons, the first of which was that “Defendants’ advertising efforts were specifically designed to evoke in consumers’ minds Plaintiffs’ renowned marks and characters in an effort to trade on their popularity and goodwill.”¹⁸⁰⁸ Second, “Defendants’ fair use defense also fails because [Defendants’] advertisements across multiple platforms consistently used Plaintiffs’ recognizable marks *as marks* “to attract public attention.”¹⁸⁰⁹ The plaintiffs therefore were entitled to summary judgment on the issue.

That outcome notwithstanding, the inherently factual nature of the descriptive fair use inquiry led to the failure of another motion for summary judgment, one filed by a group of counterclaim defendants.¹⁸¹⁰ Those parties sold T-shirts on which they affixed images of Marilyn Monroe and what the counterclaim plaintiffs suing them claimed was the MARILYN word mark. Although not definitely resolving the issue in the counterclaim plaintiffs’ favor, the court was decidedly unsympathetic to the counterclaim defendants’ motion. In denying it, the court held that “the

¹⁸⁰⁴ *Id.* at 1027.

¹⁸⁰⁵ *Id.* (quoting *Marketquest Grp. v. BIC Corp.*, 862 F.3d 927, 936 (9th Cir. 2017)).

¹⁸⁰⁶ *Id.* at 1028.

¹⁸⁰⁷ *See Disney Enters. v. Sarelli*, 322 F. Supp. 3d 413 (S.D.N.Y.), *reconsideration denied*, No. 16 CIV. 2340 (GBD), 2018 WL 5019745 (S.D.N.Y. Sept. 26, 2018).

¹⁸⁰⁸ *Id.* at 431.

¹⁸⁰⁹ *Id.* at 432 n.12.

¹⁸¹⁰ *See A.V.E.L.A., Inc. v. Estate of Marilyn Monroe, LLC*, 364 F. Supp. 3d 291 (S.D.N.Y. 2019).

[counterclaim defendants] have used the likeness of Monroe to *sell* their shirts, not to describe them. The image of Marilyn Monroe does not describe a t-shirt; rather, the product being sold is a ‘Marilyn Monroe t-shirt.’”¹⁸¹¹ “This fact,” it concluded, “is both obvious and sufficient to foreclose a defense of fair use.”¹⁸¹²

iii. Nominative Fair Use

Although the applicability of the nominative fair use doctrine is typically a question of fact, the Ninth Circuit saw fit to affirm the dismissal of an infringement and unfair competition action at the pleadings stage under the doctrine.¹⁸¹³ The plaintiff falling victim to that disposition used its APPLIED UNDERWRITERS and EQUITY COMP marks in connection with payroll processing services and workers’ compensation programs, while the defendants provided online seminars. When it discovered material critical of its services in several of the defendants’ seminars, the plaintiff filed suit seeking relief against the defendants’ use of its marks in the seminars. Although reversing the district court’s dismissal of the plaintiff’s complaint as a sanction, the Ninth Circuit held that dismissal nevertheless was appropriate under the familiar tripartite *New Kids on the Block* test:

[A] commercial user is entitled to a nominative fair use defense provided he meets the following three requirements: First, the product or service in question must be one not readily identifiable without use of the trademark; second, only so much of the mark or marks may be used as is reasonably necessary to identify the product or service; and third, the user must do nothing that would, in conjunction with the mark, suggest sponsorship or endorsement by the trademark holder.¹⁸¹⁴

Addressing the first factor, the court proved unsympathetic to the plaintiff’s argument that, despite criticizing the plaintiff’s services in particular, the defendants could have used other readily understood generic or descriptive references to those services; instead, as the court explained, “Defendants’ use of the ‘Applied Underwriters’ mark was not necessarily redundant because it was used to identify the company that offered EquityComp—a company that was itself critiqued in the seminar.”¹⁸¹⁵ With respect to the second factor, the plaintiff relied on the volume of the defendants’

¹⁸¹¹ *Id.* at 323.

¹⁸¹² *Id.*

¹⁸¹³ See *Applied Underwriters, Inc. v. Lichtenegger*, 913 F.3d 884 (9th Cir. 2019).

¹⁸¹⁴ *Id.* at 893 (quoting *New Kids on the Block v. News Am. Publ’g, Inc.*, 971 F.2d 302, 308 (9th Cir. 1992)).

¹⁸¹⁵ *Id.* at 894.

references to its marks, but the court discounted that consideration because the defendants did not use the marks with the same visual trappings as did the plaintiff, which mattered because “[o]ur case law demonstrates that analysis of this factor should focus not on the number of uses of Plaintiffs’ marks, but on whether Defendants used more of each individual mark than was necessary in terms of font and stylization.”¹⁸¹⁶ The court then disposed of the plaintiff’s argument that the defendants’ uses created the impression of sponsorship or endorsement by the plaintiff, finding that the critical nature of the defendants’ seminars precluded such a result.¹⁸¹⁷ The case therefore presented a “rare situation” in which dismissal at the pleadings stage was appropriate.¹⁸¹⁸

That was not the only opinion to dispose of the nominative fair use doctrine as a matter of law, and indeed, a California federal district court rejected an attempted invocation of it in a case in which automaker Daimler AG challenged the sale of wheels bearing copies of its registered marks.¹⁸¹⁹ The court eschewed an application of its reviewing court’s *New Kids on the Block* test, however. Instead, it did so for a more fundamental reason, namely, that “[t]he nominative fair use analysis is appropriate where a defendant has used the plaintiff’s mark to describe the plaintiff’s product, even if the defendant’s ultimate goal is to describe his own product.”¹⁸²⁰ Specifically:

[I]f Defendants’ website was worded as Defendants describe to the Court, i.e., “We Sell Replica Mercedes Benz Wheels” or “Our Wheels Look Great on Mercedes-Benz Cars!”, then the Court would agree with Defendants that the nominative fair use test applies and proceed to analyze the factors of the test. Certain postings on Defendants’ website support Defendants’ contention, but many do not. . . . There is no indication that Defendants are using Plaintiff’s “Mercedes-Benz” mark to describe Plaintiff’s product. Defendants are not using the mark to compare their wheels to Plaintiff’s

¹⁸¹⁶ *Id.* at 895. The plaintiff’s argument on this issue focused on the defendants’ use of the federal registration symbol in conjunction with the plaintiff’s marks, which the court determined was “not a particularly compelling argument.” *Id.* at 896. It then elaborated on this point with the following observation:

Although Defendants did use the ® symbol, the email attached to the complaint clarified that “EquityComp is the registered trademark of [Plaintiff].” Moreover, in the body of the email (and on the DVD cover), the title of the seminar—which did feature both the “Applied Underwriters” and “EquityComp” marks—was in regular font beneath a stylized logo for [the lead defendant] . . .

Id. (footnote omitted).

¹⁸¹⁷ *Id.* at 897.

¹⁸¹⁸ *Id.*

¹⁸¹⁹ See *Daimler AG v. A-Z Wheels LLC*, 334 F. Supp. 3d 1087 (S.D. Cal. 2018).

¹⁸²⁰ *Id.* at 1098 (quoting *Cairns v. Franklin Mint Co.*, 292 F.3d 1139, 1151 (9th Cir. 2002)).

wheels, and do not even reference Plaintiff's wheels in the online postings. Defendants are using the mark solely to describe their own products.¹⁸²¹

"Therefore," the court concluded on Daimler's motion for summary judgment, "the nominative fair use analysis is not appropriate in this situation."¹⁸²²

So too did another pair of defendants unsuccessfully claimed its protection on the parties' cross-motions for summary judgment.¹⁸²³ Although the Second Circuit has held that nominative fair use is not a true defense but instead something to be overcome by plaintiffs,¹⁸²⁴ the New York federal district court hearing the case both referred to the doctrine as a "defense"¹⁸²⁵ and ignored the multifactor test for it set forth by its reviewing court.¹⁸²⁶ The court did, however, correctly recognize that "the nominative fair use defense exists to protect the 'use of another's trademark to identify, not the defendant's goods or services, but the plaintiff's goods or services.'"¹⁸²⁷ Because the summary judgment record established that the defendants' use of the plaintiffs' marks was to promote their own services, the plaintiffs, and not the defendants, were entitled to prevail without the need for a trial.¹⁸²⁸

Finally, addressing the nominative fair use doctrine for the first time, the D.C. Circuit endorsed applications of the *New Kids on the Block* factors by the federal district courts answering to it.¹⁸²⁹ Unfortunately for those courts, the appellate court declined to take a position on whether the doctrine is an affirmative defense, on the

¹⁸²¹ *Id.* (citations omitted).

¹⁸²² *Id.*

¹⁸²³ See *Disney Enters. v. Sarelli*, 322 F. Supp. 3d 413 (S.D.N.Y.), *reconsideration denied*, No. 16 CIV. 2340 (GBD), 2018 WL 5019745 (S.D.N.Y. Sept. 26, 2018).

¹⁸²⁴ See *Int'l Info. Sys. Sec. Certification Consortium, Inc. v. Sec. Univ., LLC*, 823 F.3d 153, 167 (2d Cir. 2016) ("[W]e reject the . . . treatment of nominative fair use as an affirmative defense.").

¹⁸²⁵ *Disney Enters.*, 322 F. Supp. 3d at 432.

¹⁸²⁶ See *Int'l Info. Sys. Sec. Certification Consortium*, 823 F.3d at 168 ("When considering a likelihood of confusion in nominative fair use cases, *in addition to* discussing each of the [likelihood-of-confusion] factors, courts are to consider: (1) whether the use of the plaintiff's mark is necessary to describe both the plaintiff's product or service and the defendant's product or service, that is, whether the product or service is not readily identifiable without use of the mark; (2) whether the defendant uses only so much of the plaintiff's mark as is necessary to identify the product or service; and (3) whether the defendant did anything that would, in conjunction with the mark, suggest sponsorship or endorsement by the plaintiff holder, that is, whether the defendant's conduct or language reflects the true or accurate relationship between plaintiff's and defendant's products or services.").

¹⁸²⁷ *Disney Enters.*, 322 F. Supp. 3d at 432 (quoting *Int'l Info. Sys. Sec. Certification Consortium*, 823 F.3d at 168).

¹⁸²⁸ *Id.*

¹⁸²⁹ See *Am. Soc'y for Testing & Materials v. Public.Resource.Org, Inc.*, 896 F.3d 437 (D.C. Cir. 2018).

one hand, or something to be overcome as part of a plaintiff's prima facie case, on the other. Instead, the court inconclusively held that "under no formulation can a court ignore the nominative fair use factors altogether;"¹⁸³⁰ instead, "[w]here, as here, there is a claim of nominative fair use, the likelihood of confusion analysis remains incomplete without at least some discussion of these factors."¹⁸³¹

These observations came in an action brought by private organizations that had developed technical standards eventually incorporated by reference into law by legislatures and agencies.¹⁸³² When the defendant, a non-profit organization with the goal of making the law and other governmental materials more accessible, scanned the plaintiffs' standards into digital files and then posted them on a public website, sometimes altering them in the process, the plaintiffs filed suit on the theory that the defendant's reproductions of their marks constituted infringement. Although the district court entered summary judgment in the plaintiffs' favor after reaching a finding of likely confusion as a matter of law, the court of appeals vacated that disposition. Addressing the first *New Kids on the Block* factor, the court remarked:

Assuming that [the defendant] may reproduce some of the technical standards under copyright's fair use doctrine for the purpose of informing the public about the law, it is hard to see how [the defendant] could fulfill that goal without identifying the standard by its name—the very name also used in the incorporating law.¹⁸³³

It then held the second factor relevant because it might well be that "[the defendant] overstepped when it reproduced both [the lead plaintiffs'] logo and its word marks" ¹⁸³⁴ Finally, with respect to the third factor, the court concluded that "the disclaimers [the defendant] appends to many of its copies of the standards may well fail to adequately eliminate the possibility a consumer would assume sponsorship or endorsement by [the lead plaintiff], but that

¹⁸³⁰ *Id.* at 457.

¹⁸³¹ *Id.*

¹⁸³² The court summarized the varying ways in which that incorporation could occur:

One way in which the incorporated standards vary is how readily they resemble ordinary, binding law. At one end of this spectrum lie incorporated standards that define one's legal obligations just as much as, say, a local building code—except that the specific legal requirements are found outside the two covers of the codebook. . . . These laws impose legally binding requirements

At the other end of the spectrum lie standards that serve as mere references but have no direct legal effect on any private party's conduct. . . .

Of course, between those two poles are countless other varieties of incorporation.

Id. at 442-43 (citations omitted).

¹⁸³³ *Id.* at 457.

¹⁸³⁴ *Id.*

hardly means that no disclaimer could cure that risk.”¹⁸³⁵ It therefore remanded the action with instructions to the district court “to consider in the first instance whether [the defendant’s] use of [the lead plaintiff’s] marks constitutes trademark infringement in light of the nominative fair use factors.”¹⁸³⁶ Moreover, it added, “even if the district court ultimately concludes that the record supports an infringement finding, it should consider whether its previous grant of an injunction barring all unauthorized use is still warranted or whether it ‘may order defendants to modify their use of the mark so that all three factors are satisfied’ and a narrower remedy would suffice.”¹⁸³⁷

iv. Fraudulent Declaration of Incontestability

The defense that a plaintiff has defrauded the USPTO by submitting a fraudulent declaration of incontestability under Section 15 of the Act is not one on the merits to a claim of liability, but instead bears only on the evidentiary status of the registration in question; if proven, the allegation reduces the otherwise conclusive evidence of the registered mark’s validity to prima facie evidence under Section 33(b)(1).¹⁸³⁸ A rare successful assertion of a Section 33(b)(1) defense came in the latest installment of the long-running litigation in *B&B Hardware, Inc. v. Hargis Industries*.¹⁸³⁹ At a far earlier stage in the parties’ dispute, a jury had found the plaintiff’s registered mark invalid because the mark was descriptive and lacked acquired distinctiveness. Despite that adverse finding, the plaintiff subsequently filed a declaration of incontestability for the registration under Section 15 of the Act, in which its signatory necessarily averred that there had been no final decision adverse to the plaintiff’s claim of ownership of the mark. When the parties renewed their dispute, the issue of the validity of the Section 15 filing was placed before a different jury, which found the plaintiff had defrauded the Office by not disclosing the earlier adverse determination.

¹⁸³⁵ *Id.*

¹⁸³⁶ *Id.* at 458.

¹⁸³⁷ *Id.* (quoting *Toyota Motor Sales, U.S.A., Inc. v. Tabari*, 610 F.3d 1171, 1176 (9th Cir. 2010)).

¹⁸³⁸ 15 U.S.C. § 1115(b)(1) (2018). Regarding the effect of establishing a defense recognized by Section 33(b), see *Park 'N Fly, Inc. v. Dollar Park & Fly, Inc.*, 469 U.S. 189, 199 n.6 (1985) (“[T]he . . . defenses enumerated in § 33(b) are not substantive rules of law which go to the validity or enforceability of an incontestable mark. Instead, the defenses affect the evidentiary status of registration where the owner claims the benefit of a mark’s incontestable status. If one of the defenses is established, registration constitutes only prima facie and not conclusive evidence of the owner’s right to exclusive use of the mark.” (citation omitted)).

¹⁸³⁹ 912 F.3d 445 (8th Cir. 2018), *cert. denied*, 140 S. Ct. 218 (2019)).

On the plaintiff's appeal, the Eighth Circuit declined to overturn the jury's finding of fraud, noting correctly that "[f]ailure to disclose an adverse decision is critical because 'the PTO does not examine the merits of a § 15 affidavit, which is entered into PTO records without regard to its substantive sufficiency as long as it is received at the proper time and lacks facial inconsistencies or omissions.'"¹⁸⁴⁰ It also held that the jury had been within its rights to reject the plaintiff's claim that it "did not realize the jury verdict was a final decision and it did not disclose that verdict based on the advice of counsel";¹⁸⁴¹ "[the plaintiff's] owner so testified at trial," the court observed, but "the jury was entitled to disbelieve him if it chose."¹⁸⁴²

One aspect of the court's holding, however, rested on less secure doctrinal moorings. Addressing the materiality of the false Section 15 declaration, the court held that "[f]raud on the PTO consists of willfully withholding material information that, if disclosed, would result in an unfavorable outcome. We define 'material information' in this context as 'information that a reasonable examiner would have considered important' when making her decision."¹⁸⁴³ This formulation of materiality departs from that applied by courts and the Board alike, which have long held that materiality requires a showing that the Office would have not taken a particular action in the absence of the challenged statement.¹⁸⁴⁴ The Eighth Circuit's test for materiality—whether an examiner would have considered an applicant's statement important—departs from this "but-for" standard and, indeed, is largely indistinguishable from the standard for materiality historically used in patent infringement cases presenting claims of inequitable conduct.¹⁸⁴⁵ And, of equal

¹⁸⁴⁰ *B&B Hardware*, 912 F.3d at 451 (quoting *Gutier v. Hugo Boss Trade Mark Mgmt. GmbH & Co. KG*, 555 F. App'x 947, 949 (Fed. Cir. 2014)).

¹⁸⁴¹ *Id.* at 452.

¹⁸⁴² *Id.*

¹⁸⁴³ *Id.* at 451 (citation omitted) (quoting *Gilbert/Robinson, Inc. v. Carrie Beverage-Mo., Inc.*, 989 F.2d 985, 992 (8th Cir. 1993), *abrogated on other grounds* by *Lexmark Int'l, Inc. v. Static Control Components, Inc.*, 572 U.S. 118 (2014)).

¹⁸⁴⁴ *See, e.g.*, *Modern Fence Techs., Inc. v. Qualipac Home Improvement Corp.*, 726 F. Supp. 2d 975, 991 (E.D. Wis. 2010) (denying defense motion for summary judgment because "it is not clear . . . that, but for the misrepresentation regarding advertising, the federal registrations would not or should not have issued"); *Dragon Bleu (SARL) v. VENM, LLC*, 112 U.S.P.Q.2d 1925, 1928 (T.T.A.B. 2014) (granting motion to dismiss cause of action for fraudulent procurement averring counterclaim respondent had fraudulently represented nature of use of mark and observing that "[t]he Examining Attorney's determination of whether there is a likelihood of confusion was not based on what use [the counterclaim respondent] planned to make of the mark upon registration, but was based on the identification of goods and services as set forth in the application"); *cf.* *NSM Res. Corp. v. Microsoft Corp.*, 113 U.S.P.Q.2d 1029, 1034 (T.T.A.B. 2014) (dismissing for failure to state a claim cause of action for fraudulent procurement grounded in registrant's alleged misuse of ® symbol in connection with mark not at issue in proceeding).

¹⁸⁴⁵ *See, e.g.*, *Halliburton Co. v. Schlumberger Tech. Corp.*, 925 F.2d 1435, 1440 (Fed. Cir. 1991) ("Information is material [for inequitable conduct purposes] if there is 'substantial

importance, the Federal Circuit had rejected that standard years earlier in *Therasense, Inc. v. Becton, Dickinson & Co.*¹⁸⁴⁶ by holding that “as a general matter, the materiality required to establish inequitable conduct is but-for materiality.”¹⁸⁴⁷

v. Statutes of Limitations

The Lanham Act does not contain a statute of limitations,¹⁸⁴⁸ but a Virginia federal district court saw fit to apply one in dismissing the counterclaims of the defendants in an action originating in an appeal from a decision of the Trademark Trial and Appeal Board.¹⁸⁴⁹ The counterclaims had originally been brought in a separate action in California and included causes of action under the law of that state, so the Virginia court sought to determine the statute of limitations applicable to comparable torts in the Golden State. Although finding a split in authority on that issue (three years vs. four years),¹⁸⁵⁰ the court ultimately found it unnecessary to pick one or the other. That was because, whatever the appropriate period, the defendants had missed the applicable deadline for asserting their federal claims by more than a decade.¹⁸⁵¹ Moreover, the same was true of their California causes of action.¹⁸⁵²

Another opinion considering a statute-of-limitations-based defense came from the Eighth Circuit,¹⁸⁵³ which addressed the time limit for challenging deceptive trade practices under South Dakota law.¹⁸⁵⁴ The relevant statute required plaintiffs to act within “four years after the occurrence or discovery of the conduct which is the

likelihood that a reasonable examiner would consider it important in deciding whether to allow the application to issue as a patent.” (quoting 37 C.F.R. § 1.56 (1989)); *Flushing Bank v. Green Dot Corp.*, 138 F. Supp. 3d 561, 592 (S.D.N.Y. 2015) (“[An allegedly fraudulent] statement must pertain to a material fact—i.e. one that would have affected the USPTO’s action on the application.”).

¹⁸⁴⁶ 649 F.3d 1276 (Fed. Cir. 2011) (en banc).

¹⁸⁴⁷ *Id.* at 1291.

¹⁸⁴⁸ *See, e.g.*, *Solar Reflections, LLC v. Solar Reflections Glass Tinting, LLC*, 256 F. Supp. 3d 1248, 1255 n.7 (N.D. Ala. 2017) (“[W]hile an analogous state statute of limitation may provide a ‘touchstone’ for the timeliness of a Lanham Act claim, it operates only in the context of laches, not as a traditional limitation period.”).

¹⁸⁴⁹ *See Belmora, LLC v. Bayer Consumer Care AG*, 338 F. Supp. 3d 477 (E.D. Va. 2018), *appeal docketed*, No. 18-2183 (4th Cir. Oct. 9, 2018).

¹⁸⁵⁰ *Compare Internet Specialties W., Inc. v. Milon-DiGiorgio Enters.*, 559 F.3d 985, 990 n.2 (9th Cir. 2009) (four years) *with Small Axe Enters. v. Amscan, Inc.*, Case No. 16-CV-981, 2017 WL 1479236, at *4 (S.D. Cal. Apr. 24, 2017) (three years).

¹⁸⁵¹ *Belmora*, 338 F. Supp. 3d at 484-85.

¹⁸⁵² *Id.* at 485.

¹⁸⁵³ *See Sturgis Motorcycle Rally, Inc. v. Rushmore Photo & Gifts, Inc.*, 908 F.3d 313 (8th Cir. 2018), *on remand*, 129 U.S.P.Q.2d 1392 (D.S.D. 2019).

¹⁸⁵⁴ *See* S.D. Codified Laws § 37-24-33 (West 2004).

subject of the action.”¹⁸⁵⁵ The presence of the word “or” in the statutory language led the court to reject the defendants’ argument that, because they had undertaken their unlawful conduct more than four years prior to the filing of the plaintiff’s complaint, they were immune to a finding of liability. As the court explained, the district court had properly instructed the jury that the plaintiff could challenge acts occurring within four years of the plaintiff’s *discovery* of them.¹⁸⁵⁶

vi. Violations of Antitrust Law

Other than in the Federal Trade Commission’s attacks on past settlement agreements in trademark litigation,¹⁸⁵⁷ allegations of antitrust violations arose in two reported opinions. In the first, the plaintiff accused the defendants of monopoly power in the market for “branded naproxen sodium,” which consisted of only the parties’ goods.¹⁸⁵⁸ Rather than addressing the merits of that claim, the court noted that “the proponent of an antitrust claim must present expert testimony to establish its proposed market definition and that, without such testimony, the claim fails for lack of competent evidence on an essential element.”¹⁸⁵⁹ Because the plaintiff had failed to proffer expert testimony on that issue, the court disposed of the plaintiff’s antitrust-based causes of action on that basis by granting the defendants’ motion for summary judgment.¹⁸⁶⁰

On a wholly different subject, Section 33(b)(7) of the Lanham Act recognizes as an affirmative defense “[t]hat the mark has been or is being used to violate the antitrust laws of the United States.”¹⁸⁶¹ As a technical matter, Section 33(b)(7) applies only to the “prima facie” or “conclusive” evidence represented by registrations on the Principal Register,¹⁸⁶² but defendants frequently assert it as a

¹⁸⁵⁵ *Sturgis Motorcycle Rally*, 908 F.3d at 340 (quoting S.D. Codified Laws § 37-24-33).

¹⁸⁵⁶ *Id.* at 340-41.

¹⁸⁵⁷ *In re 1-800 Contacts, Inc.*, No. 9372, 2018 WL 6078349 (F.T.C. Nov. 14, 2018), *appeal docketed sub nom. 1-800 Contacts, Inc. v. U.S. Fed. Trade Comm’n*, No 18-3848 (2d Cir. Dec. 18, 2018).

¹⁸⁵⁸ *See Belmora, LLC v. Bayer Consumer Care AG*, 338 F. Supp. 3d 477, 487 (E.D. Va. 2018), *appeal docketed*, No. 18-2183 (4th Cir. Oct. 9, 2018).

¹⁸⁵⁹ *Id.*

¹⁸⁶⁰ *Id.*

¹⁸⁶¹ 15 U.S.C. § 1115(b)(7) (2018).

¹⁸⁶² As the Supreme Court has explained:

[T]he seven defenses enumerated in § 33(b) are not substantive rules of law which go to the validity or enforceability of an incontestable mark. Instead, the defenses affect the evidentiary status of registration where the owner claims the benefit of a mark’s incontestable status. If one of the defenses is established, registration constitutes only prima facie and not conclusive evidence of the owner’s right to exclusive use of the mark.

defense to the merits of allegations of infringement against them. An Illinois federal district court hearing such a misguided invocation of the defense reached the commonsense holding that an actual finding of an antitrust violation is a prerequisite for claiming the defense's protection.¹⁸⁶³ Thus, having dismissed the counterclaim plaintiffs' antitrust cause of action for failure to state a claim, the court not surprisingly granted the counterclaim defendant's motion to dismiss the counterclaim plaintiffs' Section 33(b)(7) defense as well. In doing so, it rejected the counterclaim plaintiffs' argument that Section 33(b)(7) operated as an independent affirmative defense.¹⁸⁶⁴

b. Equitable Defenses

i. Unclean Hands

The affirmative defense of unclean hands “bars relief to a plaintiff who has violated conscience, good faith or other equitable principles in his prior conduct, as well as to a plaintiff who has dirtied his hands in acquiring the right presently asserted.”¹⁸⁶⁵ One example of a failed assertion of unclean hands came courtesy of the Eighth Circuit.¹⁸⁶⁶ The plaintiff in the appeal before that court had successfully convinced a jury of the defendants' willful misconduct when infringing the plaintiff's marks, only to have the district court hold the plaintiff's bid for monetary relief barred by laches and acquiescence. According to the plaintiff, the defendants' willfulness constituted unclean hands that disqualified the defendants from invoking the protection of equity, but the court disagreed. As it explained, “[t]o bind the district court's equitable powers, a jury's findings must be on an issue ‘common’ to the action's legal and equitable claims; otherwise, the court is free to treat the jury's findings as ‘merely advisory’ under Federal Rule of Civil Procedure 39(c).”¹⁸⁶⁷ The court acknowledged it was possible to give willfulness a common definition in the context of the plaintiff's legal claim for an award of actual damages, on the one hand, and in the context of the defendant's equitable defenses, on the other. Nevertheless, it was equally possible that “the legal issue of willfulness in this case,

Park 'N Fly, Inc. v. Dollar Park & Fly, Inc., 469 U.S. 189, 199 n.6 (1985) (citation omitted).

¹⁸⁶³ See *Maui Jim, Inc. v. SmartBuy Guru Enters.*, 386 F. Supp. 3d 926 (N.D. Ill. 2019).

¹⁸⁶⁴ *Id.* at 956.

¹⁸⁶⁵ *Obesity Research Inst., LLC v. Fiber Research Int'l, LLC*, 310 F. Supp. 3d 1089, 1130 (S.D. Cal.) (quoting *Dollar Sys., Inc. v. Avcar Leasing Sys., Inc.*, 890 F.2d 165, 173 (9th Cir. 1989)), *motion to certify denied*, No. 15-cv-00595-BAS-MDD, 2018 WL 1791611 (S.D. Cal. Apr. 16, 2018).

¹⁸⁶⁶ See *Sturgis Motorcycle Rally, Inc. v. Rushmore Photo & Gifts, Inc.*, 908 F.3d 313 (8th Cir. 2018), *on remand*, 129 U.S.P.Q.2d 1392 (D.S.D. 2019).

¹⁸⁶⁷ *Id.* at 343.

i.e., for purposes of [monetary relief], was distinct from the equitable issue, *i.e.*, for purposes of unclean hands.”¹⁸⁶⁸ Moreover, even if commonality existed, there were two reasons why the district court had not abused its discretion in rejecting the plaintiff’s claim of unclean hands: (1) “even if the defendants engaged in ‘willful act[s] concerning the cause of action which rightfully can be said to transgress equitable standards of conduct,’ the district court may still have the discretion not to apply the doctrine of unclean hands”;¹⁸⁶⁹ and (2) “the district court could [have] conclude[d] that the jury’s willfulness findings do not have record support.”¹⁸⁷⁰

At the trial court level, another claim of unclean hands failed even to make it past the pleadings stage, instead falling victim to a motion to dismiss.¹⁸⁷¹ The plaintiff successfully challenging that defense was a manufacturer of sunglasses that accused the defendants as having trafficked in glasses bearing counterfeit copies of the plaintiff’s registered marks; for their part, the counterclaim defendants claimed to sell genuine, if diverted, goods. They asserted that unclean hands barred the plaintiff’s claims because:

[The plaintiff] broadly asserts Lanham Act claims that unfairly and improperly intend to restrain legitimate competition in genuine . . . products [produced by the plaintiff and] sold outside distribution channels that [the plaintiff] desires and the prosecution of these claims is undertaken with unclean hands, rendering [the plaintiff’s] asserted rights unenforceable.¹⁸⁷²

Granting the plaintiff’s motion to dismiss, the court agreed that the defense could not stand because it relied solely on the fact of the plaintiff’s suit against the defense:

“The allegedly unfair or improper filing of a trademark infringement lawsuit cannot itself constitute a basis for an unclean hands defense to that lawsuit.” This is because “[t]he act of bringing the lawsuit is not the subject matter concerning which plaintiff seeks relief. Unclean hands must relate to the getting [of] or using the alleged trademark rights.”¹⁸⁷³

The difficulty in asserting unclean hands based on the mere fact of the plaintiff’s lawsuit was equally apparent in an opinion

¹⁸⁶⁸ *Id.* at 344.

¹⁸⁶⁹ *Id.* (alteration in original) (quoting *Precision Instrument Mfg. Co. v. Auto. Maint. Mach. Co.*, 324 U.S. 806, 815 (1945)).

¹⁸⁷⁰ *Id.* at 345.

¹⁸⁷¹ *See Maui Jim, Inc. v. SmartBuy Guru Enters.*, 386 F. Supp. 3d 926 (N.D. Ill. 2019).

¹⁸⁷² *Id.* at 956.

¹⁸⁷³ *Id.* at 957 (alteration in original) (quoting J. Thomas McCarthy, McCarthy on Trademarks and Unfair Competition § 31:51 (5th ed. 2018)).

granting a preliminary injunction against the defendants' infringement and likely dilution of the plaintiff's mark.¹⁸⁷⁴ According to the defendants, the plaintiff could not claim the benefits of equitable relief because it was pursuing the litigation in bad faith with the goal of crippling the defendants' business. The court was unconvinced, noting as an initial matter that "[t]o sustain the defense of unclean hands, [the defendants] must show that the [plaintiff] has engaged in 'inequitable conduct or bad faith where the misconduct has a material relation to the equitable relief that plaintiff seeks.'"¹⁸⁷⁵ It then rejected the defendants' claim on the merits because "[the defendants] do[] not allege that the [plaintiff] has engaged in inequitable conduct that has a material relation to the relief the [plaintiff] seeks, such as infringing another entity's trademark or copying someone's logo."¹⁸⁷⁶

A similar formulation of the defense led to another court's rejection of it on the parties' cross-motions for summary judgment.¹⁸⁷⁷ One of the primary claims at issue in the case was whether the counterclaim defendant had falsely advertised the extent to which the results of a third-party study substantiated the claimed weight-loss properties of the counterclaim defendant's dietary supplements. With the court having found at least some of the counterclaim defendant's advertising was literally false, the counterclaim defendants asserted an unclean hands defense, pursuant to which, the court held, "[the counterclaim defendant] must show that [the counterclaim plaintiff] engaged in similar false advertising of its product that related to the . . . Study."¹⁸⁷⁸ The summary judgment record demonstrated that, like the counterclaim defendant, the counterclaim plaintiff had cited the study in support of claims it had made for its own competitive products; unlike the counterclaim defendant's advertising, however, that of the counterclaim plaintiff identified seventeen other studies without tying any particular one to the claims in question. That consideration proved fatal to the counterclaim defendant's invocation of the defense: "Because [the counterclaim defendant] fails to provide evidence that [the counterclaim plaintiff] is engaged in any similar misleading or false advertising, the Court denies [the counterclaim defendant's] request for summary judgment on the doctrine of unclean hands."¹⁸⁷⁹

¹⁸⁷⁴ See *Museum of Modern Art v. MOMACHA IP LLC*, 339 F. Supp. 3d 361 (S.D.N.Y. 2018).

¹⁸⁷⁵ *Id.* at 381 (quoting *Stokely-Van Camp, Inc. v. Coca-Cola Co.*, 646 F. Supp. 2d 510, 532 (S.D.N.Y. 2009)).

¹⁸⁷⁶ *Id.* at 382.

¹⁸⁷⁷ See *Obesity Research Inst., LLC v. Fiber Research Int'l, LLC*, 310 F. Supp. 3d 1089 (S.D. Cal.), *motion to certify denied*, No. 15-cv-00595-BAS-MDD, 2018 WL 1791611 (S.D. Cal. Apr. 16, 2018).

¹⁸⁷⁸ *Id.* at 1131.

¹⁸⁷⁹ *Id.*

Nevertheless, one reported opinion gave claims of unclean hands at least some credence.¹⁸⁸⁰ Having registered a composite mark, the plaintiff's predecessor continued to use the registration symbol in conjunction with the mark's dominant verbal element even after the other elements were phased out. The defendants argued that that usage constituted unclean hands as a matter of law, but, as the court determined from the summary judgment record assembled by both parties, the defendants used the same symbol next to their own name, even though they had never applied to register it; that circumstance led the plaintiff to argue that "[the defendants'] own misuse precludes [them] from relying on the unclean-hands doctrine."¹⁸⁸¹ The court rejected both those assertions, at least for purposes of the cross-motions for summary judgment before it: "Because there are genuine disputes of material facts as to the requisite intent and the degree of culpability of both [sides], summary judgment is inappropriate."¹⁸⁸²

ii. Laches

"Laches is an equitable defense that prevents a plaintiff, who with full knowledge of the facts, acquiesces in a transaction and sleeps upon his rights."¹⁸⁸³ As has increasingly been the case in recent years, courts differed in the test for laches, albeit in nonmaterial ways. For example, some courts adopted a two-part test holding that "[t]o demonstrate laches, the defendant must prove both an unreasonable delay by the plaintiff and prejudice to itself."¹⁸⁸⁴ In contrast, however, others applied a three-part test that required defendants asserting the defense to prove "(1) the trademark owner knew about the infringement, (2) the owner unreasonably delayed challenging it, and (3) the delay hurt the infringer."¹⁸⁸⁵

When undertaking the first step of the laches analysis (whatever the form that analysis might take), many courts have traditionally turned to the statutes of limitations applicable to corresponding

¹⁸⁸⁰ See *Deckers Outdoor Corp. v. Australian Leather Pty. Ltd.*, 340 F. Supp. 3d 706 (N.D. Ill. 2018).

¹⁸⁸¹ *Id.* at 720.

¹⁸⁸² *Id.*

¹⁸⁸³ *Obesity Research Inst., LLC v. Fiber Research Int'l, LLC*, 310 F. Supp. 3d 1089, 1129 (S.D. Cal.) (quoting *Danjaq, LLC v. Sony Corp.*, 263 F.3d 942, 950-51 (9th Cir. 2001)), *motion to certify denied*, No. 15-cv-00595-BAS-MDD, 2018 WL 1791611 (S.D. Cal. Apr. 16, 2018).

¹⁸⁸⁴ *Id.* (quoting *Danjaq*, 263 F.3d at 950-51); *accord VitalGo, Inc. v. Kreg Therapeutics, Inc.*, 370 F. Supp. 3d 873, 884 (N.D. Ill. 2019); *Smartling, Inc. v. Skawa Innovation Ltd.*, 358 F. Supp. 3d 124, 153-54 (D. Mass. 2019).

¹⁸⁸⁵ *Ausable River Trading Post, LLC v. Dovetail Sols., Inc.*, 902 F.3d 567, 572 (6th Cir. 2018); *accord A.V.E.L.A., Inc. v. Estate of Marilyn Monroe, LLC*, 364 F. Supp. 3d 291, 320 (S.D.N.Y. 2019).

state-law torts as benchmarks. Courts applying that methodology have held that “[f]or claims brought after [the state statute of limitations], there is a presumption of laches so that the trademark owner must show the inequity of dismissal on that basis.”¹⁸⁸⁶ In contrast, “[f]or claims brought within [that period], ‘there is no presumption of laches and the burden remains on the [infringer] to prove the defense.’”¹⁸⁸⁷ This rule led the Second Circuit to rely on a New York statute of limitations of six years as a benchmark.¹⁸⁸⁸ In contrast, and, without tying its holding to Illinois law, a federal district court of that state held that “[i]n trademark . . . cases, any suit filed three years or more after the first allegedly infringing use is presumptively untimely for laches.”¹⁸⁸⁹

Although laches is an equitable doctrine, several opinions offered up reminders that factual disputes can at times preclude its acceptance or rejection as a matter of law. That outcome transpired in an appeal to the Second Circuit from the grant of a defense motion for summary judgment based on the counterclaim plaintiff’s alleged knowledge of the counterclaim defendant’s conduct for seven years before challenging it.¹⁸⁹⁰ On appeal, the counterclaim plaintiff successfully pointed to evidence in the summary judgment record that, although it was aware of certain uses of the counterclaim defendant’s mark, it did not know of the counterclaim defendant’s claimed violation of a prior settlement agreement between the parties until much later. The court of appeals agreed with the counterclaim plaintiff that, “[p]roperly construing the evidence and drawing all inferences in [the counterclaim plaintiff’s] favor, less than four years passed before [the counterclaim plaintiff] brought suit.”¹⁸⁹¹ Equally to the point, the counterclaim plaintiff had not sat back and watched the counterclaim defendant’s activities in silence. On the contrary, it had earlier opposed certain applications by the counterclaim defendant before the Trademark Trial and Appeal Board and believed it had restricted use of the counterclaim defendant’s use through the settlement agreement; moreover, it had sought to enforce that agreement in litigation in Oregon state court (albeit unsuccessfully). Consequently, “it is not as if [the counterclaim plaintiff] did nothing on learning of [the counterclaim defendant’s] use of the mark, leaving [the counterclaim defendant]

¹⁸⁸⁶ *Excelled Sheepskin & Leather Coat Corp. v. Or. Brewing Co.*, 897 F.3d 413, 419 (2d Cir. 2018).

¹⁸⁸⁷ *Id.* (quoting *Conopco, Inc. v. Campbell Soup Co.*, 95 F.3d 187, 191 (2d Cir. 1996)).

¹⁸⁸⁸ *Id.*

¹⁸⁸⁹ *See VitalGo, Inc. v. Kreg Therapeutics, Inc.*, 370 F. Supp. 3d 873, 884 (N.D. Ill. 2019).

¹⁸⁹⁰ *See Excelled Sheepskin & Leather Coat Corp.*, 897 F.3d at 419.

¹⁸⁹¹ *Id.* at 420.

to believe there was no impediment to its exploitation of [the disputed mark].”¹⁸⁹²

A factual dispute on the same issue similarly sank another defendant’s motion for summary judgment.¹⁸⁹³ The defendant’s allegedly infringing conduct began in “late 2011,” and the plaintiff filed and served its original complaint in 2014. For reasons not apparent in the court’s opinion, the defendant volunteered that “between November 2011 and approximately July 2013, [the plaintiff] did not view [the defendant] as a serious competitor.”¹⁸⁹⁴ The defendant’s concession precluded the grant of its motion for summary judgment because, as the court explained, “[t]hat [the plaintiff] waited until there was some significant impact on its business before filing its lawsuit may be excusable delay.”¹⁸⁹⁵

In a case in which no such statute of limitations made an appearance, the counterclaim defendant moved the court for summary judgment based on its claim that the counterclaim plaintiff had known about the counterclaim defendant’s false advertising for a decade before challenging it.¹⁸⁹⁶ In support of its motion, the counterclaim defendant introduced e-mail correspondence from the principal of the plaintiff’s predecessor in which he complained about the counterclaim defendant’s marketing practices. Unfortunately for the counterclaim defendant, the court’s review of the e-mails disclosed that “[the predecessor’s principal’s] ‘threats’ to take legal action are unrelated to the core false advertising issues in this lawsuit”;¹⁸⁹⁷ instead, they related only to “issue[s] . . . distinct from the issue at hand.”¹⁸⁹⁸ In light of the inconclusive nature of the counterclaim defendant’s showing, the court concluded that the length and the reasonableness of the plaintiff’s delay presented a jury question inappropriately resolved on summary judgment.¹⁸⁹⁹

Finally, the same outcome held in a case in which the counterclaim defendants’ claim of laches rested on a circa-2006 demand letter forwarded by a predecessor of the lead counterclaim plaintiff to a licensee of the lead counterclaim defendant.¹⁹⁰⁰ The

¹⁸⁹² *Id.*

¹⁸⁹³ *See Smartling, Inc. v. Skawa Innovation Ltd.*, 358 F. Supp. 3d 124 (D. Mass. 2019).

¹⁸⁹⁴ *Id.* at 154.

¹⁸⁹⁵ *Id.*

¹⁸⁹⁶ *See Obesity Research Inst., LLC v. Fiber Research Int’l, LLC*, 310 F. Supp. 3d 1089 (S.D. Cal.), *motion to certify denied*, No. 15-cv-00595-BAS-MDD, 2018 WL 1791611 (S.D. Cal. Apr. 16, 2018).

¹⁸⁹⁷ *Id.* at 1130.

¹⁸⁹⁸ *Id.*

¹⁸⁹⁹ *Id.*

¹⁹⁰⁰ *See A.V.E.L.A., Inc. v. Estate of Marilyn Monroe, LLC*, 364 F. Supp. 3d 291 (S.D.N.Y. 2019).

counterclaim defendants argued the letter was proof of the lead counterclaim plaintiff's knowledge of the lead counterclaim defendant's allegedly unlawful conduct, while the counterclaim plaintiffs argued it reflected knowledge only of the licensee's activities. For purposes of the counterclaim defendants' motion for summary judgment, the court credited the counterclaim plaintiffs' assessment of the letter. It therefore denied the motion by holding, "[i]f anything, this cease and desist letter suggests that [the lead counterclaim defendant] should have become aware of the [lead counterclaim plaintiff] or its predecessors in 2006, rather than the reverse. It does not substantiate the affirmative defense of laches."¹⁹⁰¹

If, as the opinions discussed immediately above suggest, claims of laches are sometimes inappropriately resolved as a matter of law on motions for summary judgment, the same is true where motions to dismiss are concerned. One pair of defendants learning that lesson over the past year asserted in such a motion that the plaintiffs had long known of the defendants' plans to introduce a hospital bed directly competitive with those of the plaintiffs.¹⁹⁰² As the court pointed out, however, "even if the Plaintiffs knew or should have known that Defendants were developing a competing bed, they could not have known in 2011 that Defendants would use Plaintiffs' intellectual property to market that bed"¹⁹⁰³ Specifically, the court concluded:

Defendants have not pointed to any allegations indicating that Plaintiffs knew, or should have known, that Defendants would use [Plaintiffs'] mark[s] in connection with the marketing and sale of [Defendants' bed]. Even if Plaintiffs suspected such a plan, Plaintiffs' claims did not become cognizable until Defendants' actively began using Plaintiffs' marks in conjunction with [Defendants' bed] in commerce.¹⁹⁰⁴

"That said," the court observed, "should discovery show otherwise, Defendants may raise an argument based on laches in a motion for summary judgment."¹⁹⁰⁵

iii. Acquiescence

The sole reported opinion squarely to address the affirmative defense of acquiescence held that "[t]here are three elements of estoppel by acquiescence: (1) the plaintiff made assurances to the

¹⁹⁰¹ *Id.* at 321.

¹⁹⁰² *See* *VitalGo, Inc. v. Kreg Therapeutics, Inc.*, 370 F. Supp. 3d 873 (N.D. Ill. 2019).

¹⁹⁰³ *Id.* at 884.

¹⁹⁰⁴ *Id.*

¹⁹⁰⁵ *Id.* at 885.

defendant that it would not enforce its trademark rights; (2) the defendant relied on these assurances; and (3) enforcement of the plaintiff's rights would substantially prejudice the defendant."¹⁹⁰⁶ The court did so in an opinion denying a motion to dismiss that asserted two bases for the defendants' claim they had satisfied the initial prong of the required analysis. The defendants first claimed that the plaintiffs had sent a demand letter only years after the defendants applied to register the challenged mark, but the court rejected that argument based on allegations in the plaintiffs' complaint that they had objected to the defendants' conduct on a timelier basis.¹⁹⁰⁷ The defendants next asserted the plaintiffs had failed to enforce their rights against alleged third-party infringers, but the court declined to consider that argument in light of the absence of any allegations in the complaint potentially supporting it.¹⁹⁰⁸

iv. Estoppel

One court held that:

For estoppel, Defendants . . . need evidence to prove each of . . . five [sic] elements: (1) Plaintiff knew of Defendants' actions; (2) Plaintiff's actions led Defendants to reasonably believe Plaintiff did not intend to enforce its trademark rights; (3) Defendants did not know that Plaintiff actually objected to Defendants' conduct; and (4) Defendants will be materially prejudiced if Plaintiff is allowed to proceed.¹⁹⁰⁹

Unfortunately for the defendants to whom this restatement of the defense was directed, their response to a motion for summary judgment failed to do anything more than assert that, because the plaintiff used an outside law firm to manage its trademark portfolio, it was logical for the plaintiff to have known the defendants had falsely changed the record address of two of registrations owned by a subsidiary of the plaintiff. The court held that circumstance did not prevent entry of summary judgment in the plaintiff's favor, holding, "[t]his evidence alone does not create a triable issue because Defendants only speculate as to what Plaintiff's personnel could have discovered in managing the marks, with no actual evidence of delay on Plaintiff's part."¹⁹¹⁰

¹⁹⁰⁶ *Helpful Hound, L.L.C. v. New Orleans Bldg. Corp.*, 333 F. Supp. 3d 593, 602 (E.D. La. 2018).

¹⁹⁰⁷ *Id.* at 602-03.

¹⁹⁰⁸ *Id.* at 603.

¹⁹⁰⁹ *AECOM Energy & Constr., Inc. v. Ripley*, 348 F. Supp. 3d 1038, 1060 n.17 (C.D. Cal. 2018) (quoting *Marketquest Grp. v. BIC Corp.*, 316 F. Supp. 3d 1234, 1294-95 (S.D. Cal. 2018)), *reconsideration denied*, No. CV 17-5398-RSWL-SSx, 2019 WL 2610953 (C.D. Cal. Apr. 24, 2019), *appeal docketed*, No. 19-55588 (9th Cir. May 2, 2019).

¹⁹¹⁰ *Id.* at 1061.

v. Waiver

The affirmative defense of waiver came into play in few reported opinions over the past year. One of the few to address it held that “to establish waiver, Defendants would need to provide evidence showing a ‘clear, decisive, and unequivocal’ intent by Plaintiff to relinquish its trademark rights.”¹⁹¹¹ With the defendants in the case leading to that opinion having failed to make a factual showing addressing those requirements, the court had little trouble entering summary judgment in the plaintiff’s favor.¹⁹¹²

3. Remedies

a. Injunctive Relief

i. Prerequisites for Injunctive Relief

In *eBay Inc. v. MercExchange, LLC*,¹⁹¹³ the Supreme Court identified four showings a plaintiff must make to be entitled to permanent injunctive relief:

(1) that it has suffered an irreparable injury; (2) that remedies available at law such as monetary damages are inadequate to compensate for that injury; (3) that, considering the balance of hardships between the plaintiff and defendant, a remedy in equity is warranted; and (4) that the public interest would not be disserved by a permanent injunction.¹⁹¹⁴

In *eBay*’s wake, the Court subsequently held in *Winter v. Natural Resources Defense Council, Inc.*¹⁹¹⁵ that the same factors applied in the preliminary injunction context.¹⁹¹⁶ Courts hearing trademark and unfair competition cases addressed each of these prerequisites—but especially the first—over the past year.

(A) Irreparable Harm

As always, at least some reported opinions entered injunctive relief by applying the traditional rule that a demonstration of success (or likely success, in the case of a preliminary injunction) on claims of infringement, false advertising, or unfair competition created a presumption of irreparable harm.¹⁹¹⁷ For example, one

¹⁹¹¹ *Id.* at 1060 n.17 (C.D. Cal. 2018) (quoting *Marketquest*, 316 F. Supp. 3d at 1294-95).

¹⁹¹² *Id.* at 1060-61.

¹⁹¹³ 547 U.S. 388 (2006).

¹⁹¹⁴ *Id.* at 391.

¹⁹¹⁵ 555 U.S. 7 (2008).

¹⁹¹⁶ *Id.* at 20.

¹⁹¹⁷ *See, e.g.*, *Entm’t One UK Ltd. v. 2012Shiliang*, 384 F. Supp. 3d 941, 955 (N.D. Ill. 2019) (“The first . . . requirement[], irreparable harm . . . , [is] presumed in trademark

court held that “in trademark cases, ‘a sufficiently strong showing of likelihood of confusion . . . may by itself constitute a showing of a substantial threat of irreparable harm.’”¹⁹¹⁸ Likewise, another granted a permanent injunction in a false advertising action after observing that “[t]he potential for ongoing harm if a defendant continues to make similar false or misleading statements and the likely impossibility of quantifying the extent of harm suffered as a result of false or misleading statements weigh in favor of finding irreparable injury.”¹⁹¹⁹ Other courts reached holdings to similar effect.¹⁹²⁰

infringement cases.”); *Marco’s Franchising, LLC v. Soham, Inc.*, 365 F. Supp. 3d 891, 894 (N.D. Ohio 2019) (“If the movant is likely to succeed on an infringement claim, irreparable injury is ordinarily presumed, and the public interest will usually favor injunctive relief.” (quoting *Ne. Ohio Coal. for Homeless v. Husted*, 696 F.3d 580, 590-91 (6th Cir. 2012)); *Chanel, Inc. v. Replicachanelbag*, 362 F. Supp. 3d 1256, 1263 (S.D. Fla. 2019) (“[I]n trademark cases, ‘a sufficiently strong showing of likelihood of confusion . . . may by itself constitute a showing of a substantial threat of irreparable harm.’” (second alteration in original) (quoting *McDonald’s Corp. v. Robertson*, 147 F.3d 1301, 1306 (11th Cir. 1998)); *Canes Bar & Grill of S. Fla., Inc. v. Sandbar Bay, LLC*, 343 F. Supp. 3d 1236, 1246 (S.D. Fla. 2018) (“The Eleventh Circuit [extends] a presumption of irreparable harm once a plaintiff establishes a likelihood of success on the merits of a trademark infringement claim.” (quoting *N. Am. Med. Corp. v. Axiom Worldwide, Inc.*, 522 F.3d 1211, 1227 (11th Cir. 2008)); *Safeway Transit LLC v. Disc. Party Bus, Inc.*, 334 F. Supp. 3d 995, 1007 (D. Minn. 2018) (“[The plaintiffs] [have] shown irreparable harm because, in trademark law, ‘injury is presumed once a likelihood of confusion has been established.’” (quoting *Copyright Corp. v. Devon Park Restoration Branch of Jesus Christ’s Church*, 634 F.3d 1005, 1012 (8th Cir. 2011)), *appeal docketed*, No. 18-2990 (8th Cir. Sept. 17, 2018); *H-D U.S.A., LLC v. SunFrog, LLC*, 311 F. Supp. 3d 1000, 1050 (E.D. Wis.) (“[B]ecause of the difficulty in quantifying damage to the reputation or goodwill of a mark holder, courts presume irreparable harm and the inadequacy of legal remedies in Lanham Act cases.”), *appeal dismissed*, No. 18-2073, 2018 WL 6039900 (7th Cir. July 19, 2018).

¹⁹¹⁸ *Chanel, Inc. v. Replicachanelbag*, 362 F. Supp. 3d 1256, 1263 (S.D. Fla. 2019) (alteration in original) (quoting *McDonald’s Corp. v. Robertson*, 147 F.3d 1301, 1306 (11th Cir. 1998)).

¹⁹¹⁹ *Ill. Tool Works Inc. v. Rust-Oleum Corp.*, 346 F. Supp. 3d 951, 955-56 (S.D. Tex. 2018), *appeal docketed*, No. 19-20210 (5th Cir. Apr. 4, 2019).

¹⁹²⁰ *See, e.g., MillerCoors, LLC v. Anheuser-Busch Cos.*, 385 F. Supp. 3d 730, 757 (W.D. Wis. 2019) (similarly holding in false advertising action that “it is well settled that injuries arising from Lanham Act violations are presumed to be irreparable, even if the plaintiff fails to demonstrate a business loss” (quoting *Promatek Indus. v. Equitrac Corp.*, 300 F.3d 808, 813 (7th Cir. 2002)), *modified*, No. 19-cv-218-wmc, 2019 WL 4187489 (W.D. Wis. Sept. 4, 2019), *and modified*, No. 19-cv-218-wmc, 2019 WL 4247725 (W.D. Wis. Sept. 6, 2019), *remanded on other grounds*, 940 F.3d 922 (7th Cir. 2019); *Spangler Candy Co. v. Tootsie Roll Indus.*, 372 F. Supp. 3d 588, 607-08 (N.D. Ohio) (“Generally, ‘in the context of an infringement action, a finding of irreparable injury ordinarily follows when a likelihood of confusion or possible risk to reputation appears [because] irreparable injury flows both from the potential difficulty of proof of plaintiff’s damages, and also from the impairment of intangible values.” (alteration in original) (quoting *Wynn Oil Co. v. Am. Way Serv. Corp.*, 943 F.2d 595, 608 (6th Cir. 1991))), *appeal dismissed*, No. 19-3227, 2019 WL 2564576 (6th Cir. May 10, 2019); *TrueNorth Cos. v. TruNorth Warranty Plans of N. Am., LLC*, 353 F. Supp. 3d 788, 801 (N.D. Iowa 2018) (“Without additional guidance from the Eighth Circuit on this issue, I find it prudent to consider irreparable harm under the traditional analysis (requiring plaintiff to show more than a possibility of harm), without allowing for a presumption based on likelihood of success.”); *Museum of Modern Art v.*

In contrast, some courts have interpreted *eBay* and *Winter* as having done away with the presumption of irreparable harm.¹⁹²¹ The potentially significant effect of *eBay*'s possible abrogation of the presumption of irreparable harm was perhaps most apparent in a proceeding before a New York federal district court in which the prevailing plaintiff failed to prove its eligibility for injunctive relief despite the absence of any opposition to its request for a default judgment.¹⁹²² Without controlling authority from the Second Circuit on the issue, the court followed the lead of other Second Circuit district courts in holding the presumption defunct.¹⁹²³ Turning to the allegations of harm in the plaintiff's complaint, the court noted that "[c]onspicuously absent from plaintiff's submissions is any proof of consumer complaints or confusion regarding defendants' products, or of the inferior quality of defendants' products relative to plaintiff's."¹⁹²⁴ "Nor," for that matter, "does plaintiff make any showing of a drop-off in its sales since the point at which defendants' products entered the U.S. market."¹⁹²⁵ Although the plaintiff attempted to salvage its position by citing to the defendants' failure to comply with its demand letters, the court held that:

[P]laintiff's argument begs the question of whether it has in fact been irreparably injured; even assuming *arguendo* that defendants are likely to continue their infringing conduct, a finding that plaintiff has plausibly alleged a likelihood of confusion does not, without the benefit of a discredited presumption, satisfy plaintiff's obligation to establish actual past or imminent injury under the *eBay* four-factor test.¹⁹²⁶

The court therefore denied the plaintiff's request for a permanent injunction even in the absence of the defendants' opposition to that request.

Another New York federal district court went so far as to forego consideration of all other aspects of a preliminary injunction motion

MOMACHA IP LLC, 339 F. Supp. 3d 361, 382-83 (S.D.N.Y. 2018) (applying presumption of irreparable harm but also accepting plaintiff's factual showing grounded in defendants' use of infringing mark in connection with beverages infused with cannabis and the plaintiff's receipt of a misdirected communication threatening litigation).

¹⁹²¹ See, e.g., Obesity Research Inst., LLC v. Fiber Research Int'l, LLC, 310 F. Supp. 3d 1089, 1127-28 (S.D. Cal.) (declining to apply presumption of irreparable harm in false advertising litigation and additionally concluding that factual disputes warranted referring issue to jury), *motion to certify denied*, No. 15-cv-00595-BAS-MDD, 2018 WL 1791611 (S.D. Cal. Apr. 16, 2018).

¹⁹²² See *Kohler Co. v. Bold Int'l FZCO*, 127 U.S.P.Q.2d 1459 (E.D.N.Y.), *report and recommendation adopted in relevant part*, No. 17-cv-4233 (LDH) (RLM), 2018 WL 4804655 (E.D.N.Y. Oct. 4, 2018).

¹⁹²³ *Id.* at 1482.

¹⁹²⁴ *Id.* at 1483.

¹⁹²⁵ *Id.*

¹⁹²⁶ *Id.* (footnotes omitted).

after concluding the plaintiff had failed to demonstrate irreparable harm in the absence of the requested relief.¹⁹²⁷ The plaintiff apparently did not invite the court to presume it was suffering the required harm from the defendants' alleged infringement, and, in any case, the court held that "[e]ven assuming that potential customers would likely be confused . . . , a likelihood of confusion does not create a presumption of irreparable injury."¹⁹²⁸ With the presumption thus a dead article as far as the court was concerned, the plaintiff's factual evidence of harm fell short. That evidence arose from the parties' past relationship, in which the lead defendant served as national director for several of the plaintiff's beauty pageant divisions. When the relationship ran its course, the lead defendant removed content containing the plaintiff's marks from certain websites and social media accounts she controlled, but she did not turn over to the plaintiff either the domain names at which the sites were accessible or the social accounts. Under those circumstances, the court found, the plaintiff's claims that prospective contestants or customers of the plaintiff had been or were likely to be diverted to competing pageants associated with the defendants rested on mere speculation.¹⁹²⁹ The disposition of the plaintiff's request for injunctive relief therefore awaited summary judgment motions or trial.¹⁹³⁰

Lacking clear guidance from the Tenth Circuit, a Colorado federal district court similarly declined to apply the presumption in the context of a preliminary injunction motion.¹⁹³¹ After surveying out-of-circuit appellate opinions, it concluded that:

The Court finds the logic of these cases persuasive. Although plaintiff argues that the trademark context is fundamentally different from patents in that trademark law aims to protect the rights of consumers rather than private rights, the Court agrees . . . that the Supreme Court's decision in *eBay* was not predicated on the unique nature of patent cases, but on the principle that courts may not depart from "the long tradition of equity practice" absent a clear congressional mandate to do so. . . . The Court joins other courts in this district in finding that *eBay* abrogated the presumption of irreparable harm traditionally applied in trademark infringement cases.¹⁹³²

¹⁹²⁷ See *Mrs. United States Nat'l Pageant, Inc. v. Williams*, 353 F. Supp. 3d 213 (W.D.N.Y. 2019).

¹⁹²⁸ *Id.* at 221 n.5 (quoting *Ardis Health, LLC v. Nankivell*, No. 11 Civ. 5013(NRB), 2011 WL 4965172, at *5 (S.D.N.Y. 2011)).

¹⁹²⁹ *Id.* at 218-20.

¹⁹³⁰ *Id.* at 221.

¹⁹³¹ See *Dalkita, Inc. v. Distilling Craft, LLC*, 356 F. Supp. 3d 1125 (D. Colo. 2018).

¹⁹³² *Id.* at 1132-33.

Still other courts were skeptical of both the presumption of irreparable harm and the plaintiffs' factual proof of that harm,¹⁹³³ especially if that proof rested on unsupported allegations of reputational harm.¹⁹³⁴ For example, having unsuccessfully invoked the presumption in support of its motion for a preliminary injunction, one plaintiff fell equally short in relying on the threat posed by the defendant's continued conduct to its reputation.¹⁹³⁵ In the absence of supporting evidence, the court declined the plaintiff's invitation to find that "any accident attributable to [defendants] will . . . have a catastrophic and irreparable impact on plaintiff's reputation."¹⁹³⁶ Instead, the court held:

[T]here is a loss of control in every case where a trademark is infringed. To demonstrate a likelihood of irreparable injury, plaintiff must do more than assert a loss of control over [its] trademark. Plaintiff must establish that its loss of control is likely to have an adverse impact on its reputation or customer base while this case is pending.¹⁹³⁷

A more detailed showing similarly failed before a skeptical Washington federal district court.¹⁹³⁸ With the court rejecting its attempted invocation of the presumption,¹⁹³⁹ the plaintiff argued that its sales had failed to meet projections, which it attributed to purchasers of the defendant's alleged lower quality goods believing the goods were those of the plaintiff and the resulting damage to its reputation. With respect to the alleged lost sales, the court concluded from the preliminary injunction record before it that:

Defendant aptly questions whether failing to meet an ambitious growth rate can constitute irreparable harm. The Court agrees and further finds that Plaintiff has not adequately tied its decreased sales to Defendant's actions.

¹⁹³³ See, e.g., *Mrs. United States Nat'l Pageant, Inc. v. Williams*, 353 F. Supp. 3d 213, 219 (W.D.N.Y. 2019) (denying preliminary injunction because "plaintiff's alleged harm can either be compensated by money damages, or is speculative, neither of which is sufficient to establish irreparable harm").

¹⁹³⁴ See, e.g., *Rush v. Hillside Buffalo, LLC*, 314 F. Supp. 3d 477, 483 (W.D.N.Y. 2018) (denying request for temporary restraining order because "conclusory statements of loss of reputation will not justify an irreparable harm finding." (quoting *Alzheimer's Found. of Am., Inc. v. Alzheimer's Disease & Related Disorders Ass'n, Inc.*, No. 10 Civ. 3314 (RWS), 2015 WL 4033019, at *11 (S.D.N.Y. June 29, 2015)); *Evoqua Water Techs. LLC v. M.W. Watermark, LLC*, 128 U.S.P.Q.2d 1775, 1784 (W.D. Mich. 2018) (finding that defendants' voluntary cessation of use of infringing use two years before trial weighed against finding of reputational harm).

¹⁹³⁵ See *Dalkita, Inc. v. Distilling Craft, LLC*, 356 F. Supp. 3d 1125 (D. Colo. 2018).

¹⁹³⁶ *Id.* at 1134.

¹⁹³⁷ *Id.*

¹⁹³⁸ See *Comphy Co. v. Amazon.com, Inc.*, 371 F. Supp. 3d 914 (W.D. Wash. 2019).

¹⁹³⁹ *Id.* at 929 ("Plaintiff merely asks this Court to presume that irreparable harm is imminent. But misuse of a trademark no longer results in a presumption of irreparable harm.").

Defendant's actions could possibly be the sole cause for the reduction in Plaintiff's anticipated sales and an injunction could possibly result in an uptick in sales. But it may not. Indeed, Plaintiff only conveys its *belief* that it would not fall short of its growth target in the absence of Defendant's actions.¹⁹⁴⁰

Then, rejecting the plaintiff's claim of reputational damage, the court found that "Plaintiff presents evidence of consumer confusion and dissatisfaction. . . . When combined with consumer dissatisfaction that may be attributed to Plaintiff's brand, the harm is cognizable but still must be presumed on the record before the Court."¹⁹⁴¹ Finally, citing the online nature of the defendant's business, the court recognized "a . . . high[] chance that, if liable, Defendant could contact almost every purchaser of the allegedly inferior products and seek to repair any damage that may have been done to Plaintiff's brand."¹⁹⁴²

Without reference to the presumption's viability, a New York federal district court similarly demolished a claim of irreparable harm by a plaintiff that had successfully demonstrated the falsity of its opponent's advertising as part of a preliminary injunction motion.¹⁹⁴³ The court's analysis began with its observation that "where proof of actual or expected lost sales may be difficult to show, some courts find irreparable harm upon a showing that (i) the parties are competitors in the relevant market; and (ii) there is a logical causal connection between the alleged false advertising and the plaintiff's own sales position."¹⁹⁴⁴ The parties were indisputably direct competitors, but the record failed to establish the required nexus between the defendant's advertising and the plaintiff's sales. Indeed, "[the plaintiff's] share of the overall yogurt market improved, and . . . [the plaintiff] itself had its second-best ever market share in its product class, during the month when [the defendant's goods] came to market."¹⁹⁴⁵ "This data [sic]," the court found, "strongly suggests that neither [the plaintiff's] sales position nor its brand equity has suffered irreparably."¹⁹⁴⁶ Things got worse for the plaintiff from there: Not only had the defendant already introduced modified packaging into the marketplace, the plaintiff's own packaging contained stale and inaccurate claims, and the latter consideration in particular "undermines any suggestion that [the

¹⁹⁴⁰ *Id.* (citation omitted).

¹⁹⁴¹ *Id.*

¹⁹⁴² *Id.*

¹⁹⁴³ See *Danone, US, LLC v. Chobani, LLC*, 362 F. Supp. 3d 109 (S.D.N.Y. 2019).

¹⁹⁴⁴ *Id.* at 124.

¹⁹⁴⁵ *Id.*

¹⁹⁴⁶ *Id.*

defendant's] packaging is working irreparable harm on its competitor."¹⁹⁴⁷

Nevertheless, the absence of the presumption does not prevent prevailing plaintiffs from demonstrating irreparable harm as a factual matter, especially if they claim damage to their reputations.¹⁹⁴⁸ For example, one such finding transpired in a dispute in which the court held the defendants liable as a matter of law for falsely claiming they had worked on a series of construction projects when, in fact, the plaintiff and one of its subsidiaries had done the work; to add insult to injury, the defendants posted their literally false claims on a website accessible at two domain names that incorporated the plaintiff's marks.¹⁹⁴⁹ Referencing the defendants' failure to comply with a preliminary injunction, the court found "substantial evidence that Plaintiff has suffered a loss

¹⁹⁴⁷ *Id.* at 125.

¹⁹⁴⁸ *See, e.g., MillerCoors, LLC v. Anheuser-Busch Cos.*, 385 F. Supp. 3d 730, 758 (W.D. Wis.) (applying presumption of irreparable harm but noting that, even without it, "plaintiff has put forth sufficient evidence in the form of a survey, and anecdotal social media and consumer comments, to support a finding that the reputation of its light beers has been injured by the challenged, misleading advertisements, or at least to rebut defendant's sales evidence to the contrary"), *modified*, No. 19-cv-218-wmc, 2019 WL 4187489 (W.D. Wis. Sept. 4, 2019), *and modified*, No. 19-cv-218-wmc, 2019 WL 4247725 (W.D. Wis. Sept. 6, 2019), *remanded on other grounds*, 940 F.3d 922 (7th Cir. 2019); *Talent Mobile Dev., Inc. v. Headios Grp.*, 382 F. Supp. 3d 953, 865 (C.D. Cal. 2019) ("The jury found infringement of the trademark, and Defendants must cease any continuous use of their infringing [marks]. To hold otherwise would hinder Plaintiff's ability to cultivate and control its reputation and goodwill with the consuming public and result in additional confusion."), *appeal docketed*, No. 19-55258 (9th Cir. Mar. 5, 2019); *Gianni Versace, S.p.A. v. Versace 19.69 Abbigliamento Sportivo SRL*, 328 F. Supp. 3d 1007, 1032 (N.D. Cal. 2018) ("Though a strong case of trademark infringement is not alone sufficient to establish irreparable harm, [the lead plaintiff] shows that it will suffer irreparable 'loss of business, reputation, and goodwill' if [the lead defendant] continues its infringing activity." (quoting *Herb Reed Enters. v. Fla. Entm't, Mgmt., Inc.*, 736 F.3d 1239, 1250 (9th Cir. 2013)), *appeal dismissed*, No. 19-15188, 2019 WL 2005744 (9th Cir. Apr. 17, 2019); *see also Spangler Candy Co. v. Tootsie Roll Indus.*, 372 F. Supp. 3d 588, 608 (N.D. Ohio) (applying presumption of irreparable harm but additionally finding that "the loss of control of its reputation by allowing [the defendant] to sell the same product in the confusingly similar bag would cause irreparable harm since 'loss of control over one's reputation is neither calculable nor precisely compensable'" (quoting *CFE Racing Prods., Inc. v. BMF Wheels, Inc.*, 793 F.3d 571, 596 (6th Cir. 2015)), *appeal dismissed*, No. 19-3227, 2019 WL 2564576 (6th Cir. May 10, 2019); *Mayson-Dixon Strategic Consulting, LLC v. Mason-Dixon Polling & Strategic Consulting, Inc.*, 324 F. Supp. 3d 569, 580 (D. Md. 2018) ("[The plaintiff] alleges that [the defendant's] use of a nearly identical service mark threatens [the plaintiff's] reputation. Because [the defendant] is a partisan political firm, [the plaintiff's] reputation as independent and non-partisan will be undermined by [the defendant's] continued use of its [infringing] trade name and mark."); *Sprint Sols., Inc. v. Lafayette*, 127 U.S.P.Q.2d 1256, 1270 (W.D. Tenn. 2018) (holding, in context of unopposed motion for default judgment, that "[c]alculating reputational damage and lost sales is inherently difficult, if not impossible, and therefore constitutes irreparable harm and establishes the inadequacy of monetary damages").

¹⁹⁴⁹ *See AECOM Energy & Constr., Inc. v. Ripley*, 348 F. Supp. 3d 1038 (C.D. Cal. 2018), *reconsideration denied*, No. CV 17-5398-RSWL-SSx, 2019 WL 2610953 (C.D. Cal. Apr. 24, 2019), *appeal docketed*, No. 19-55588 (9th Cir. May 23, 2019).

to control over its brand, goodwill, and intellectual property rights that cannot be quantified.”¹⁹⁵⁰

The same result held in an action in which a jury had held the defendants liable for infringing three marks used by the plaintiff in connection with convention services.¹⁹⁵¹ Although rejecting an invitation to find that the plaintiff had presumptively suffered irreparable harm because of the defendants’ misconduct, the California federal district court weighing the prevailing plaintiff’s request for a permanent injunction did not ask for much in terms of factual evidence of that harm. On the contrary, it accepted the plaintiff’s showing that the defendants’ infringement “had resulted in [the plaintiff] suffering from loss of goodwill and a potential inability to control its reputation.”¹⁹⁵² The court rested that conclusion on “testimony from consumers who thought that [the defendants’] convention was related to [the plaintiff’s annual] event, that consumers voiced complaints about [the defendants’] convention to [the plaintiff], and that [the defendants] [were] aware of 30 to 50 instances of confusion.”¹⁹⁵³

A factual finding of irreparable harm also occurred in an action before a Louisiana federal district court hearing a preliminary injunction motion, which questioned whether recognition of the presumption of irreparable harm remained appropriate after *eBay* and *Winter*.¹⁹⁵⁴ Once again, the specter of damage to the mark owner’s reputation carried the day, with the court finding that “[t]he potential harm to [the counterclaim] plaintiffs’ reputation and goodwill cannot be quantified, and rises to the level of irreparable harm.”¹⁹⁵⁵ As the court summarized the preliminary injunction record, “[the counterclaim defendants] have appropriated a mark that the [counterclaim plaintiffs] [have] maintained for a century. Now, [the counterclaim] plaintiffs have ‘lost control’ of the quality of the services associated with their mark.”¹⁹⁵⁶

In granting a different preliminary injunction motion, a Utah federal district court hearing an action between competitors in the market for protein pancake mixes found as an initial matter that “Plaintiff has failed to provide a strong showing of loss of goodwill or reputational damage as a result of Defendant’s conduct.”¹⁹⁵⁷

¹⁹⁵⁰ *Id.* at 1061.

¹⁹⁵¹ *See San Diego Comic Convention v. Dan Farr Prods.*, 336 F. Supp. 3d 1191 (S.D. Cal. 2018), *appeal docketed*, No. 18-56221 (9th Cir. Sept. 14, 2018).

¹⁹⁵² *Id.* at 1197.

¹⁹⁵³ *Id.*

¹⁹⁵⁴ *See Helpful Hound, L.L.C. v. New Orleans Bldg. Corp.*, 331 F. Supp. 3d 581, 603 (E.D. La. 2018).

¹⁹⁵⁵ *Id.*

¹⁹⁵⁶ *Id.*

¹⁹⁵⁷ *Kodiak Cakes LLC v. Cont’l Mills, Inc.*, 358 F. Supp. 3d 1219, 1236 (D. Utah 2019).

Nevertheless, it ultimately reached a finding of irreparable harm based on the plaintiff's showings of actual confusion and that "the number of actual customers purchasing Defendant's product by mistake is impossible to ascertain."¹⁹⁵⁸ It then focused on the plaintiff's allegations of monetary damage, of which it observed:

Plaintiff has provided sales data which shows that, after Defendant introduced the accused packaging, Defendant's sales of its protein mix increased while Plaintiff's sales decreased. While Defendant is correct that this evidence does not conclusively demonstrate that the accused packaging has resulted in lost sales, it provides support for Plaintiff's claim that it has and is continuing to lose customers and its competitive position is weakened based on Defendant's alleged infringement. Based upon this, the amount of damages would be difficult, if not impossible to ascertain, and Plaintiff has shown it is likely to suffer irreparable harm without the issuance of an injunction.¹⁹⁵⁹

The plaintiff therefore was entitled to the relief it sought.

So too did a Nevada federal district court find irreparable harm based on a combination of claimed reputational damage and other considerations.¹⁹⁶⁰ The plaintiff owned Las Vegas casinos and hotels, while the defendants operated online casinos through websites that prominently featured imitations of the plaintiff's registered marks. In accepting the plaintiff's uncontested argument that a preliminary injunction was appropriate to prevent the defendants from transferring the domain names, the court found that "[t]he potential for Plaintiff's inability to recover based upon [the] [apparent status of Defendants as Chinese nationals], the risk that Defendants may transfer the domains to registrars outside this Court's jurisdiction, and Defendants' unwillingness to participate in this case all counsel in favor of a finding of irreparable harm."¹⁹⁶¹ Moreover, and as a final consideration, "loss of goodwill and control over Plaintiff's reputation can reasonably be inferred because of the distinct similarities between the marks and their use in a manner contrary to Plaintiff's public stance against online gaming."¹⁹⁶²

Of course, even if a plaintiff otherwise demonstrates the existence of irreparable harm, that showing can be rendered moot by the plaintiff's delay in seeking injunctive relief, especially in the preliminary injunction or temporary restraining order contexts.¹⁹⁶³

¹⁹⁵⁸ *Id.*

¹⁹⁵⁹ *Id.*

¹⁹⁶⁰ *See* Las Vegas Sands Corp. v. Fan Yu Ming, 360 F. Supp. 3d 1072 (D. Nev. 2019).

¹⁹⁶¹ *Id.* at 1081.

¹⁹⁶² *Id.*

¹⁹⁶³ *See, e.g.,* Rumfish y Vino Corp. v. Fortune Hotels, Inc., 403 F. Supp. 3d 1227, 1232 (M.D. Fla. 2019) (finding that plaintiffs' approximately six-month delay in challenging

That outcome held in an appeal to the Eighth Circuit in a case in which the plaintiffs filed an infringement suit in October 2016, but neglected to seek a preliminary injunction until March 2017.¹⁹⁶⁴ The district court found that approximate five-month delay too long, and the court of appeals agreed. Even if the presumption of irreparable harm survived *eBay*, it held, “the [plaintiff] would not be entitled to such a presumption, because they did not promptly seek preliminary injunctive relief concerning the alleged trademark infringement.”¹⁹⁶⁵

In a case predating that conclusion by its reviewing court, a Minnesota federal district court similarly concluded that a seventeen-month delay by an allegedly irreparably harmed plaintiff precluded a grant of that plaintiff’s motion for a preliminary injunction.¹⁹⁶⁶ The plaintiff sought to explain away its inaction by claiming an increase in the rate of instances of actual confusion it encountered, but the court found that “[w]hile [the plaintiff] has demonstrated some level of confusion through phone call recordings and email communications, it has not demonstrated any irreparable harm (such as loss of customers or decline in sales) based on this confusion.”¹⁹⁶⁷ The plaintiff’s delay was not the only flaw in its claim of irreparable harm, however: Instead, based on the noncompetitive nature of the parties’ respective businesses, the court dismissed the plaintiff’s averment of reputational damage as nothing more than a “speculative possibility”¹⁹⁶⁸ before additionally citing coexistence agreements between the plaintiff and two other entities using similar names.¹⁹⁶⁹ Having thus found an absence of irreparable harm, the court saw no need to evaluate the other prerequisites for preliminary injunctive relief.

Although apparently recognizing the presumption of irreparable harm,¹⁹⁷⁰ an Illinois federal district court held the presumption rebutted by an eighteen-month delay before the plaintiff sought a preliminary injunction against a competitor’s alleged infringement.

defendants’ uses of disputed service mark after learning of defendants’ applications to register the mark for the same services prevented issuance of temporary restraining order).

¹⁹⁶⁴ See *Phyllis Schlafly Revocable Tr. v. Cori*, 924 F.3d 1004 (8th Cir. 2019).

¹⁹⁶⁵ *Id.* at 1010.

¹⁹⁶⁶ See *TrueNorth Cos. v. TruNorth Warranty Plans of N. Am., LLC*, 353 F. Supp. 3d 788, 805 (N.D. Iowa 2018) (“If the harm was truly as serious, imminent and irreparable as alleged, [the plaintiff] should not have needed 17 months to bring a properly supported motion.”).

¹⁹⁶⁷ *Id.* at 802.

¹⁹⁶⁸ *Id.* at 804.

¹⁹⁶⁹ *Id.* (“[The plaintiff’s] willingness to co-exist with other entities using the same name, albeit in arguably different industries, tends to lessen the alleged harm.”).

¹⁹⁷⁰ See *Redbox Automated Retail, LLC v. Xpress Retail LLC*, 310 F. Supp. 3d 949, 952 (N.D. Ill. 2018) (“The Seventh Circuit traditionally has applied a presumption of irreparable harm in false advertising and trademark infringement suits.”).

The court did not necessarily apply a bright-line rule based on that length of time, for it acknowledged that “[i]t is true that a lengthy delay might not undermine a claim of irreparable harm if the delay was ‘caused by the plaintiff’s ignorance of the defendant’s competing product or the plaintiff’s making good faith efforts to investigate the alleged infringement.’”¹⁹⁷¹ Nevertheless, the preliminary injunction record reflected no such justification and, indeed, it established the plaintiff had looked “many times” at the defendant’s conduct during the plaintiff’s year-and-a-half of inaction.¹⁹⁷² Under the circumstances, the plaintiff failed to demonstrate the irreparable harm necessary to its request for a preliminary injunction, and the court denied that relief as a consequence;¹⁹⁷³ it then took the same step with respect to the plaintiff’s cause of action for false advertising, although the delay in asserting it had arguably been only fifteen months.¹⁹⁷⁴

In contrast, a Maryland federal district court generously held that a delay of ten months did not moot the claim of irreparable harm of a counterclaim plaintiff seeking a preliminary injunction.¹⁹⁷⁵ Much of that ten-month period was attributable to the counterclaim plaintiff’s pursuit of a federal registration for its mark, following the issuance of which the counterclaim plaintiff sent a demand letter and engaged in an unsuccessful telephone conference to resolve the matter; indeed, even after the counterclaim defendant filed its own suit, the counterclaim plaintiff requested a preliminary injunction only in conjunction with the filing of its answer and counterclaims. No matter, the court held without extended explanation, “[the counterclaim defendant] fails to show that [the counterclaim plaintiff’s] ‘delay’ forecloses a finding of irreparable harm.”¹⁹⁷⁶

(B) Inadequacy of Legal Remedies

Although one court faulted a plaintiff claiming lost sales for failing to demonstrate “why money damages are inadequate to remedy a mainly financial harm,”¹⁹⁷⁷ the second doctrinal requirement for injunctive relief, namely, the inadequacy of legal remedies, did not pose much of an obstacle to prevailing

¹⁹⁷¹ *Id.* at 953 (quoting *Tough Traveler, Ltd. v. Outbound Prods.*, 60 F.3d 964, 968 (2d Cir. 1995)).

¹⁹⁷² *Id.*

¹⁹⁷³ *Id.* at 944.

¹⁹⁷⁴ *Id.* at 955-56.

¹⁹⁷⁵ See *Mayson-Dixon Strategic Consulting, LLC v. Mason-Dixon Polling & Strategic Consulting, Inc.*, 324 F. Supp. 3d 569 (D. Md. 2018).

¹⁹⁷⁶ *Id.* at 581.

¹⁹⁷⁷ See *Comphy Co. v. Amazon.com, Inc.*, 371 F. Supp. 3d 914, 929 (W.D. Wash. 2019).

plaintiffs.¹⁹⁷⁸ For example, one court presumed it was satisfied without requiring any proof from the prevailing plaintiff.¹⁹⁷⁹ Another accepted without a substantive discussion the argument that “the monetary damages the jury awarded are inadequate to compensate [the plaintiff] for its injuries because it is difficult to quantify the extent of harm to its reputation and goodwill as a result of the [defendants’] false advertising.”¹⁹⁸⁰ Yet another court accepting the showing of the prevailing plaintiffs before it on the issue noted that “[t]he . . . loss of goodwill incurred by [the plaintiffs] renders money damages inadequate. This is especially so considering that [the defendants] [have] continued [their] infringing activity despite receiving multiple adverse judgments from foreign courts.”¹⁹⁸¹

A variation on the last of these points—but not one yielding a different result—came in an opinion from a South Carolina federal district court after that tribunal found the parties’ respective uses of the color orange on industrial safety equipment confusingly similar as a matter of law.¹⁹⁸² The only such use in public by the defendant had been a trade show, after which, having been served with the plaintiff’s complaint, the defendant placed its plans on hold pending the court’s resolution of the matter. This voluntary forbearance ironically worked to the defendant’s disadvantage when it came to the prevailing plaintiff’s bid for a permanent injunction.

¹⁹⁷⁸ See, e.g., *MillerCoors, LLC v. Anheuser-Busch Cos.*, 385 F. Supp. 3d 730, 757-58 (W.D. Wis.) (“[T]he difficulty in assessing the damages associated with a loss of goodwill supports finding that the plaintiff lacked an adequate remedy at law.”), *modified*, No. 19-cv-218-wmc, 2019 WL 4187489 (W.D. Wis. Sept. 4, 2019), and *modified*, No. 19-cv-218-wmc, 2019 WL 4247725 (W.D. Wis. Sept. 6, 2019), *remanded on other grounds*, 940 F.3d 922 (7th Cir. 2019); *Museum of Modern Art v. MOMACHA IP LLC*, 339 F. Supp. 3d 361, 383 (S.D.N.Y. 2018) (finding, without extended analysis, that “[t]his harm [to the prevailing plaintiff’s reputation] is not calculable and cannot be remedied by monetary damages”); *Sprint Sols., Inc. v. Lafayette*, 127 U.S.P.Q.2d 1256, 1271 (W.D. Tenn. 2018) (“Defendants’ scheme is ongoing. Their failure to appear suggests that their wrongful conduct will not cease absent a permanent injunction. There is no adequate remedy at law where there is a potential future harm from infringement”).

¹⁹⁷⁹ See, e.g., *Entm’t One UK Ltd. v. 2012Shiliang*, 384 F. Supp. 3d 941, 955 (N.D. Ill. 2019) (“[An] inadequate remedy at law[] [is] presumed in trademark infringement cases.”); *Chanel, Inc. v. Replicachanelbag*, 362 F. Supp. 3d 1256, 1263 (S.D. Fla. 2019) (“[I]njunctive relief is the remedy of choice for trademark and unfair competition cases, since there is no adequate remedy at law for the injury caused by a defendant’s continuing infringement.” (quoting *Burger King Corp. v. Agad*, 911 F. Supp. 1499, 1509-10 (S.D. Fla. 1995))).

¹⁹⁸⁰ *Ill. Tool Works Inc. v. Rust-Oleum Corp.*, 346 F. Supp. 3d 951, 957 (S.D. Tex. 2018), *appeal docketed*, No. 19-20210 (5th Cir. Apr. 4, 2019).

¹⁹⁸¹ *Gianni Versace, S.p.A. v. Versace 19.69 Abbigliamento Sportivo SRL*, 328 F. Supp. 3d 1007, 1032 (N.D. Cal. 2018), *appeal dismissed*, No. 19-15188, 2019 WL 2005744 (9th Cir. Apr. 17, 2019).

¹⁹⁸² See *SafeRack, LLC v. Bullard Co.*, 350 F. Supp. 3d 438 (D.S.C. 2018), *report and recommendation adopted*, No. 2:17-cv-1613-RMG, 2019 WL 460699 (D.S.C. Feb. 5, 2019).

Addressing the adequacy of legal remedies for what it had found was the defendant's infringement, the court concluded that:

[S]ince [the defendant] never sold any infringing equipment and it instead chose to "await the decision on this lawsuit" before selling the equipment with orange components, purely legal remedies are inadequate and would not prevent [the defendant] from deciding at some point in the future to sell equipment with orange railings, gates or cages.¹⁹⁸³

The plaintiff's request for permanent injunctive relief therefore was well-taken.

(C) *Balance of Hardships*

With near uniformity, courts held that the balance of hardships favored plaintiffs able to demonstrate success of the merits or, in the preliminary injunction context, a likelihood of that success.¹⁹⁸⁴ For example, one explained that "the balance of hardships favors Plaintiff because the potential hardship on Defendants is 'purely economic,' while the hardship on Plaintiff is a complete loss of control over [its] brand and history"¹⁹⁸⁵ Another found that "[t]here is 'no harm to Defendants to being enjoined from violating the law'"¹⁹⁸⁶ And, in a false advertising action in which the defendant represented it had discontinued the offending advertisements, a different court was "unpersuaded that any harm to defendant by enjoining it from displaying certain, limited advertisements and print materials outweighs the harm to plaintiff,

¹⁹⁸³ *Id.* at 455-56.

¹⁹⁸⁴ *See, e.g., Gianni Versace, S.p.A., v. Versace 19.69 Abbigliamento Sportivo SRL*, 328 F. Supp. 3d 1007, 1033 (N.D. Cal. 2018) (concluding, without extensive discussion, that "[i]n view of the substantial and uncontroverted evidence of harm to [the prevailing plaintiffs], the equities clearly weigh in [the plaintiffs'] favor"), *appeal dismissed*, No. 19-15188, 2019 WL 2005744 (9th Cir. Apr. 17, 2019); *see also Mayson-Dixon Strategic Consulting, LLC v. Mason-Dixon Polling & Strategic Consulting, Inc.*, 324 F. Supp. 3d 569, 581 (D. Md. 2018) "[The counterclaim plaintiff] will suffer irreparable harm without a preliminary injunction. Although [the counterclaim defendant] will also suffer harm if the injunction is granted, [the counterclaim defendant's] harm will be less severe and can be mitigated. [The counterclaim defendant] can continue to operate its . . . services as long as it uses a different name and mark."); *Sprint Sols., Inc. v. Lafayette*, 127 U.S.P.Q.2d 1256, 1271 (W.D. Tenn. 2018) ("[T]he balance of hardships weighs strongly in Plaintiffs' favor. Plaintiffs are threatened with irreparable injury in the absence of a permanent injunction. Injunctive relief would merely serve to force Defendants' compliance with the law.").

¹⁹⁸⁵ *AECOM Energy & Constr., Inc. v. Ripley*, 348 F. Supp. 3d 1038, 1061 (C.D. Cal. 2018), *reconsideration denied*, No. CV 17-5398-RSWL-SSx, 2019 WL 2610953 (C.D. Cal. Apr. 24, 2019), *appeal docketed*, No. 19-55588 (9th Cir. May 2, 2019).

¹⁹⁸⁶ *Entm't One UK Ltd. v. 2012Shiliang*, 384 F. Supp. 3d 941, 955 (N.D. Ill. 2019) (quoting *Light v. Zhangyali*, No. 15 CV 5918, 2016 WL 4429758, at *4 (N.D. Ill. Aug. 22, 2016)).

particularly since defendant's counsel represented it has discontinued most of these ads already."¹⁹⁸⁷

Consistent with these outcomes, one of the few opinions actually to address the issue at length similarly resolved it in favor of the prevailing plaintiff.¹⁹⁸⁸ That plaintiff had operated an annual convention under its marks "for over forty-five years," while the defendants' infringing use had begun only in 2013. "Consequently," the court concluded, "an injunction asking [the defendants] to change the name of their event would be easier and less injurious than requiring [the plaintiff] to do so."¹⁹⁸⁹ Indeed, "as [the defendants] persistently highlight[], after the jury trial, they started the process of changing their event name and as far as the Court can see, the process has been completed."¹⁹⁹⁰ Especially because the permanent injunction requested by the plaintiff would merely require the defendants to comply with the law,¹⁹⁹¹ "the balance of hardships does not just tip, but noses in favor of [the plaintiff]."¹⁹⁹²

Likewise, another court also took seriously claims of damage arising from a potential preliminary injunction before discounting them in light of the counterclaim plaintiffs' more convincing showing of harm in the absence of injunctive relief.¹⁹⁹³ The counterclaim defendants had operated a market and food hall in a New Orleans building under a lease from the counterclaim plaintiffs before making plans to open food halls in other cities using the same ST. ROCH MARKET mark as found on the New Orleans building. In response to the counterclaim plaintiffs' showing of likely confusion and a breach of what the court found to be a license governing the mark's use, the counterclaim defendants argued prospective damage arising from their inability to use the mark at their planned new locations. The court found that claim unconvincing when compared to the threat posed to the counterclaim plaintiffs' reputation:

¹⁹⁸⁷ *MillerCoors, LLC v. Anheuser-Busch Cos.*, 385 F. Supp. 3d 730, 759 (W.D. Wis.), *modified*, No. 19-cv-218-wmc, 2019 WL 4187489 (W.D. Wis. Sept. 4, 2019), *and modified*, No. 19-cv-218-wmc, 2019 WL 4247725 (W.D. Wis. Sept. 6, 2019), *remanded on other grounds*, 940 F.3d 922 (7th Cir. 2019); *accord* *Safeway Transit LLC v. Disc. Party Bus, Inc.*, 334 F. Supp. 3d 995, 1007 (D. Minn. 2018) ("[B]ecause [the lead defendant] never used the terms as its brand identity, abandoned them in 2009, and had no intent to resume use in commerce even when it registered the terms as marks in 2014, an injunction would not harm [it]."), *appeal docketed*, No. 18-2990 (8th Cir. Sept. 17, 2018).

¹⁹⁸⁸ *See* *San Diego Comic Convention v. Dan Farr Prods.*, 336 F. Supp. 3d 1191 (S.D. Cal. 2018), *appeal docketed*, No. 18-56221 (9th Cir. Sept. 14, 2018).

¹⁹⁸⁹ *Id.* at 1198.

¹⁹⁹⁰ *Id.*

¹⁹⁹¹ *Id.* at 1197.

¹⁹⁹² *Id.* at 1198.

¹⁹⁹³ *See* *Helpful Hound, L.L.C. v. New Orleans Bldg. Corp.*, 331 F. Supp. 3d 581 (E.D. La. 2018).

[A]ny harm [counterclaim] defendants may suffer is self-inflicted because [counterclaim] defendants did not have the right to use the mark in the first place. Moreover, an injunction would not prevent defendants from opening food halls in other cities, so long as the food halls are not named “St. Roch Market.” Nor would the injunction prevent defendants from continuing to operate [the original market and food hall under license] in New Orleans.¹⁹⁹⁴

Much the same analysis worked to the disadvantage of defendants accused of unlawfully imitating the packaging of protein pancake mixes.¹⁹⁹⁵ In attempting to fend off the plaintiff’s preliminary injunction motion, the defendants offered enough proof of prospective harm to justify a \$1,000,000 bond should it turn out they were wrongfully enjoined.¹⁹⁹⁶ That otherwise convincing showing did not, however, mean a balance of the hardships favored their position, especially in light of plaintiff’s evidence of declining sales, which the court attributed to the defendants’ infringement. In the final analysis, the court found, “when the case for infringement is clear, a defendant cannot avoid a preliminary injunction by claiming harm to a business built upon that infringement.”¹⁹⁹⁷

An Ohio federal district court similarly resolved the balancing inquiry in the plaintiff’s favor in a case in which the court found the appearance of the defendant’s lollipop bags confusingly similar to those of the plaintiffs.¹⁹⁹⁸ Seeking to head off a preliminary injunction, the defendant argued it had “already invested \$1 million in the product redesign and launch [that led to the lawsuit] and would have to invest more money and time into a second redesign”;¹⁹⁹⁹ moreover, “a second redesign so soon after the first could damage the company’s image as a whole.”²⁰⁰⁰ Unfortunately for the defendant, the preliminary injunction record established that “[the defendant] has already designed and is using an alternative bag for one of its three nationwide distributors.”²⁰⁰¹ “Therefore,” the court concluded, “while [the defendant] may experience some hardship in repackaging the existing inventory into the [alternative] bags, it would not be burdened with a complete

¹⁹⁹⁴ *Id.* at 604 (citation omitted).

¹⁹⁹⁵ *See* Kodiak Cakes LLC v. Cont’l Mills, Inc., 358 F. Supp. 3d 1219 (D. Utah 2019).

¹⁹⁹⁶ *Id.* at 1237.

¹⁹⁹⁷ *Id.* (quoting Gen. Motors Corp. v. Urban Gorilla, LLC, 500 F.3d 1222, 1229 (10th Cir. 2007)).

¹⁹⁹⁸ *See* Spangler Candy Co. v. Tootsie Roll Indus., 372 F. Supp. 3d 588 (N.D. Ohio), *appeal dismissed*, No. 19-3227, 2019 WL 2564576 (6th Cir. May 10, 2019).

¹⁹⁹⁹ *Id.* at 608.

²⁰⁰⁰ *Id.*

²⁰⁰¹ *Id.*

redesign.”²⁰⁰² This meant that “[b]ecause [the defendant’s] burden in transferring inventory to an existing package is substantially less than [the plaintiff’s] loss of goodwill and reputation, this factor weighs in [the plaintiff’s] favor.”²⁰⁰³

In contrast to those outcomes, a Texas federal district court found that a balance of the parties’ respective hardships merited at least a tempering of the injunctive relief requested by a plaintiff advancing a meritorious claim for false advertising.²⁰⁰⁴ The court agreed the plaintiff was entitled to a permanent injunction against the defendants’ continued dissemination of packaging bearing the offending claims, but it balked at ordering a recall of the packages already placed into the stream of commerce by the defendants. In doing so, the court credited the defendants’ argument that “recalling [the] product [in question] would greatly damage its ability to continue as a viable product and would require [the defendants] to identify all retailers who still have [the] product, buy back the product, and pay for freight and labor.”²⁰⁰⁵

And one court went further still, finding that a defendant would suffer greater harm from a preliminary injunction than would the plaintiff in the absence of that relief.²⁰⁰⁶ In doing so, it accepted the defendant’s showing that, because placing stickers on the defendant’s yogurt packaging to obscure false representations on that packaging was impractical, injunctive relief would be tantamount to a recall of a product otherwise safe for consumption. In addition, an injunction “would cost [the defendant] millions of dollars in lost sales, wasted component ingredients, wasted slotting fees, labor costs, and the logistical expenses needed to effectuate the recall properly.”²⁰⁰⁷ Finally, “[i]t also would potentially jeopardize [the defendant’s] relationships with retailers, at least in terms of its ability to put [its product] back in stores, given that [the product] is a new product without a longstanding record of consumer loyalty.”²⁰⁰⁸ “These harms,” the court found, “are more concrete than [the plaintiff’s]—at least on the evidence provided at this stage of the proceedings.”²⁰⁰⁹

²⁰⁰² *Id.* at 609.

²⁰⁰³ *Id.*

²⁰⁰⁴ *See* Ill. Tool Works Inc. v. Rust-Oleum Corp., 346 F. Supp. 3d 951 (S.D. Tex. 2018), *appeal docketed*, No. 19-20210 (5th Cir. Apr. 4, 2019).

²⁰⁰⁵ *Id.* at 956.

²⁰⁰⁶ *See* Danone, US, LLC v. Chobani, LLC, 362 F. Supp. 3d 109 (S.D.N.Y. 2019).

²⁰⁰⁷ *Id.* at 125.

²⁰⁰⁸ *Id.*

²⁰⁰⁹ *Id.* at 126.

(D) Public Interest

A plaintiff able to demonstrate infringement, likely dilution, false advertising, or another variety of unfair competition is typically in the driver's seat where the public interest is concerned.²⁰¹⁰ One opinion in a false advertising action proving that point held that “[h]aving found a likelihood of success on the merits

²⁰¹⁰ See, e.g., *Entm't One UK Ltd. v. 2012Shiliang*, 384 F. Supp. 3d 941, 955 (N.D. Ill. 2019) (“[E]liminating potential consumer confusion serves the public interest.”); *Chanel, Inc. v. Replicachanelbag*, 362 F. Supp. 3d 1256, 1264 (S.D. Fla. 2019) (“[T]he public interest supports the issuance of a permanent injunction against Defendants to prevent consumers from being misled by Defendants’ products.”); *SafeRack, LLC v. Bullard Co.*, 350 F. Supp. 3d 438, 456 (D.S.C. 2018) (entering permanent injunction after finding infringement as a matter of law and that “the public interest would be served by preventing future consumers from being misled”), *report and recommendation adopted*, No. 2:17-cv-1613-RMG, 2019 WL 460699 (D.S.C. Feb. 5, 2019); *Las Vegas Sands Corp. v. Fan Yu Ming*, 360 F. Supp. 3d 1072, 1081 (D. Nev. 2019) (“Preventing consumer confusion serves the public interest and there is a strong policy in favor of protecting rights to trademarks.’ It follows that an injunction premised upon ‘serious questions’ going to the merits of trademark infringement action serves the public interest.” (quoting *Stark v. Diageo Chateau & Estate Wines Co.*, 907 F. Supp. 2d 1042, 1067 (N.D. Cal. 2012)); *AECOM Energy & Constr., Inc. v. Ripley*, 348 F. Supp. 3d 1038, 1061 (C.D. Cal. 2018) (“[T]he public interest favors an injunction because the marks are identical and shown to have already caused actual confusion.”), *reconsideration denied*, No. CV 17-5398-RSWL-SSx, 2019 WL 2610953 (C.D. Cal. Apr. 24, 2019), *appeal docketed*, No. 19-55588 (9th Cir. May 2, 2019); *Ill. Tool Works Inc. v. Rust-Oleum Corp.*, 346 F. Supp. 3d 951, 957 (S.D. Tex. 2018) (“[T]he public interest is always served by requiring compliance with Congressional statutes such as the Lanham Act.” (quoting *Quantum Fitness Corp. v. Quantum LifeStyle Ctrs.*, 83 F. Supp. 2d 810, 832 (S.D. Tex. 1999), *appeal docketed*, No. 19-20210 (5th Cir. Apr. 4, 2019); *Canes Bar & Grill of S. Fla., Inc. v. Sandbar Bay, LLC*, 343 F. Supp. 3d 1236, 1247 (S.D. Fla. 2018) (“Since this Court has sustained Plaintiff’s objections as to (1) Likelihood of Success on the Merits, (2) Irreparable Harm and (3) Balancing of the Equities, this Court finds that ‘the public interest is served by eliminating confusion in the marketplace.’” (quoting *Pandora Jewelers 1995, Inc. v. Pandora Jewelry, LLC*, 703 F. Supp. 2d 1307, 1316 (S.D. Fla. 2010)); *San Diego Comic Convention v. Dan Farr Prods.*, 336 F. Supp. 3d 1191, 1198 (S.D. Cal. 2018) (“[A]n injunction is in the public interest because ‘[t]he public has an interest in avoiding confusion between two companies’ products.’” (quoting *Internet Specialties W., Inc. v. Milon-DiGiorgio Enters.*, 559 F.3d 985, 993 n.5 (9th Cir. 2009)), *appeal docketed*, No. 18-56221 (9th Cir. Sept. 14, 2018); *Safeway Transit LLC v. Disc. Party Bus, Inc.*, 334 F. Supp. 3d 995, 1007 (D. Minn. 2018) (“[T]he public has an interest in enforcement of valid trademarks.”), *appeal docketed*, No. 18-2990 (8th Cir. Sept. 17, 2018); *Helpful Hound, L.L.C. v. New Orleans Bldg. Corp.*, 331 F. Supp. 3d 581, 604 (E.D. La. 2018) (“Here, where plaintiffs have established a substantial likelihood of success on the merits, an injunction would serve the public interest by preventing unfair competition and protecting intellectual property. These values promoted by trademark law outweigh the public’s interest in competition and free exchange of ideas.”); *Mayson-Dixon Strategic Consulting, LLC v. Mason-Dixon Polling & Strategic Consulting, Inc.*, 324 F. Supp. 3d 569, 581 (D. Md. 2018) (“Injunctions protecting trademarks are in the public interest ‘because trademarks foster competition and the maintenance of quality by securing to the producer the benefits of good reputation.’” (quoting *San Francisco Arts & Athletics, Inc. v. U.S. Olympic Comm.*, 483 U.S. 522, 531 (1987)); *Sprint Sols., Inc. v. Lafayette*, 127 U.S.P.Q.2d 1256, 1271 (W.D. Tenn. 2018) (“An injunction enjoining Defendants from using [Plaintiffs’] Marks would advance the purposes of trademark law by preventing consumer confusion and deception in the marketplace and by protecting Plaintiffs’ property interests in the Marks.”).

as to certain of the alleged misleading statements and a finding of irreparable harm to plaintiff's reputation caused by those same statements, the court further finds that the injunction described below supports the public's interest in truthful advertising."²⁰¹¹ A different court entertaining a trademark action entered the relief sought by the plaintiff after concluding that "the public interest supports the issuance of a permanent injunction against Defendants to prevent consumers from being misled by Defendants' products."²⁰¹²

One of the few reported opinions to undertake a true balancing exercise still came down on the side of the prevailing plaintiff after finding confusion likely between the appearances of the packages in which the parties sold their lollipops.²⁰¹³ In response to the plaintiff's preliminary injunction, the defendant argued that the requested relief would have a chilling effect on competition, but the court found otherwise. In significant part, that result held because the defendant already used redesigned packaging for sales to one of its major customers. As the court observed, "[c]ompetition is not threatened if [the defendant] continues to offer [its goods] at the same competitive pricing in the already-existing alternative packaging."²⁰¹⁴

ii. Terms of Injunctive Relief

Although most disputes over the proper terms of injunctive relief focus on terms *entered* by a trial court, one appeal to the Fifth Circuit turned on the *withdrawal* of the terms at issue.²⁰¹⁵ At an earlier stage of the proceeding, the plaintiffs had successfully demonstrated the defendant's liability for false advertising and for violations of the Sherman Act. Based on that success, the district court entered a detailed permanent injunction,²⁰¹⁶ only to have the Fifth Circuit reverse the jury's finding in the plaintiffs' favor under the Sherman Act. The appellate court left open on remand the

²⁰¹¹ *MillerCoors, LLC v. Anheuser-Busch Cos.*, 385 F. Supp. 3d 730, 759 (W.D. Wis.), *modified*, No. 19-cv-218-wmc, 2019 WL 4187489 (W.D. Wis. Sept. 4, 2019), *and modified*, No. 19-cv-218-wmc, 2019 WL 4247725 (W.D. Wis. Sept. 6, 2019), *remanded on other grounds*, 940 F.3d 922 (7th Cir. 2019).

²⁰¹² *Chanel, Inc. v. Replicachanelbag*, 362 F. Supp. 3d 1256, 1264 (S.D. Fla. 2019).

²⁰¹³ *See Spangler Candy Co. v. Tootsie Roll Indus.*, 372 F. Supp. 3d 588 (N.D. Ohio), *appeal dismissed*, No. 19-3227, 2019 WL 2564576 (6th Cir. May 10, 2019).

²⁰¹⁴ *Id.* at 609.

²⁰¹⁵ *See Retractable Techs., Inc. v. Becton Dickinson & Co.*, 919 F.3d 869 (5th Cir. 2019).

²⁰¹⁶ As described by the Fifth Circuit, "[the district court] . . . crafted a six-part injunction requiring [the defendant] to cease certain advertising claims for several years, post a notice on its website, notify various entities of the false claims, and implement a training program for employees and distributors." *Id.* at 873. On the defendant's motion, however, the district court stayed the injunction's requirement that the defendant notify its end users of its false claims. *Id.*

question of whether the defendant's (unreversed) liability for false advertising continued to justify the injunction's terms.

The district court concluded it did not, and the Fifth Circuit affirmed. According to the latter, which declined to disturb the retraction of the injunction, the district court had not abused its discretion by relying on the defendant's compliance with the injunction's terms prior to the initial appeal of the matter. Specifically, "[t]he district court [properly] concluded these steps had been sufficient to remedy any injury or threat of injury [the plaintiffs] had suffered from the false advertising."²⁰¹⁷ The circumstance that the district court had stayed one aspect of its injunction pending the defendant's second appeal did not mandate the contrary result.²⁰¹⁸

The Supreme Court of Nebraska also held that a trial court had not abused its discretion when requiring a defendant found to have infringed the plaintiff's DENALI CONSTRUCTION and DENALI HOMES trade names from "using or displaying the name 'Denali' in its business in any manner whatsoever."²⁰¹⁹ Seeking to avoid having to change its corporate name with the Nebraska Secretary of State, the defendant argued that the trial court's injunction impermissibly required it to take an affirmative action. The court took a different view of the injunction, concluding that it merely prohibited the defendant "from perpetuating the confusion resulting from its registration of one name and its later operation under a variant deceptively similar to [the plaintiff's] previously registered trade names. Under these circumstances, permitting [the defendant] to revert to using only its legal corporate name would reward it for its deceptive conduct."²⁰²⁰

Another opinion similarly demonstrated the wide latitude enjoyed by trial courts when defining the terms of injunctive relief.²⁰²¹ Having infringed the COMIC CON mark for convention services, a pair of defendants found themselves faced with a request for injunctive relief against their use of phonetic equivalents of that mark. The court proved receptive to that request in an application of the rule that, "as [the defendants] [were] found by the jury to be infringers of [the plaintiff's] trademarks, they are required to 'keep a safe distance away from the margin line.'"²⁰²² It explained, "if [the defendants] were allowed to produce a new comic or popular arts

²⁰¹⁷ *Id.* at 875.

²⁰¹⁸ *Id.*

²⁰¹⁹ *See Denali Real Estate, LLC v. Denali Custom Builders, Inc.*, 926 N.W.2d 610 (Neb. 2019).

²⁰²⁰ *Id.* at 628.

²⁰²¹ *See San Diego Comic Convention v. Dan Farr Prods.*, 336 F. Supp. 3d 1191 (S.D. Cal. 2018), *appeal docketed*, No. 18-56221 (9th Cir. Sept. 14, 2018).

²⁰²² *Id.* at 1199 (quoting *Plough, Inc. v. Kreis Labs.*, 314 F.2d 635, 639 (9th Cir. 1963)).

event named ‘ComiKon’ or ‘ComicKon,’ as the pronunciation of the phrases remain identical to [the plaintiff’s] trademarks, a high likelihood of consumer confusion would still exist.”²⁰²³ It also granted the plaintiff’s request for prohibitions on the defendants’ continued maintenance of the www.saltlakecomiccon.com domain name²⁰²⁴ and promotion of their convention using a “Formerly Salt Lake Comic Con” reference.²⁰²⁵

The plaintiff in that case did not enjoy a complete victory where the terms of the permanent injunction were concerned, however. For one thing, the court refused to enjoin the defendants from marketing their competing convention by using the words “comic convention” because, it found, “[the plaintiff] has not demonstrated the likelihood that it can succeed on a claim of trademark infringement against [the defendants] for the use of [those words] in their event name.”²⁰²⁶ For another, the court also rejected the plaintiff’s argument that it should require the defendants to “destroy all of their merchandise and all marketing materials bearing the specific word combinations ‘Comic Con,’ ‘Comic-Con,’ or any phonetic equivalents”;²⁰²⁷ the better approach, the court concluded, was to allow the defendants to maintain a “historical archive” of merchandise from their past conventions, provided they did not attempt to sell those items.²⁰²⁸

In a different dispute, an Illinois federal district court joined the increasing trend of tribunals ordering asset freezes once plaintiffs have advanced colorable cases that defendants have trafficked in goods bearing counterfeit imitations of the plaintiffs’ marks.²⁰²⁹ The court ordered such a freeze as part of a preliminary injunction, and it proved disinclined to withdraw that term of the injunction at the request of the defendants, who claimed damage to their online business. It explained that “[t]o exempt assets from an asset freeze, [t]he burden is on the party seeking relief to present documentary proof that particular assets [are] not the proceeds of counterfeiting activities.”²⁰³⁰ With the defendants having failed to satisfy that burden, their request for relief from the earlier order fell short.²⁰³¹

Having found a group of defendants liable for counterfeiting as a matter of law, so too did a New York federal district court keep in

²⁰²³ *Id.* at 1198.

²⁰²⁴ *Id.* at 1200-02.

²⁰²⁵ *Id.* at 1202-03.

²⁰²⁶ *Id.* at 1199.

²⁰²⁷ *Id.* at 1200.

²⁰²⁸ *Id.*

²⁰²⁹ *See Entm’t One UK Ltd. v. 2012Shiliang*, 384 F. Supp. 3d 941 (N.D. Ill. 2019).

²⁰³⁰ *Id.* at 944-45 (second and third alterations in original) (quoting *Luxottica Grp. S.p.A. v. Li Chen*, No. 16 C 6850, 2017 WL 836228, at *5 (N.D. Ill. Mar. 2, 2017)).

²⁰³¹ *Id.* at 955.

place an asset-freeze order issued earlier in the case.²⁰³² Citing Federal Rule of Civil Procedure 62(a), which provides that “no execution may issue on a judgment, nor may proceedings be taken to enforce it, until 14 days have passed after its entry,”²⁰³³ the court found that “[w]ithout such a restraint, defendants would have fourteen days during which they could hide their assets.”²⁰³⁴ It therefore held that “[t]he restraint shall continue until plaintiffs can enforce and satisfy the judgment entered by this Court.”²⁰³⁵

Finally, one court ordered a freeze of a different sort.²⁰³⁶ The plaintiff before that tribunal used its federally registered marks in connection with casino services, while the defendants operated online casinos, the websites for which featured imitations of the plaintiff’s marks. Having previously entered a temporary restraining order barring the third-party registrants with of domain names associated with the defendants’ services, the court had little difficulty converting that relief into a preliminary injunction. It therefore ordered that “[t]he domain name registrar and registries, including but not limited to GoDaddy and VeriSign, Inc., shall maintain the Infringing Domains . . . on hold and lock pending a further order of the Court.”²⁰³⁷

iii. Security

Under ordinary circumstances, Rule 65 of the Federal Rules of Civil Procedure requires the successful movant for interlocutory relief to post a bond “in an amount that the court considers proper to pay the costs and damages sustained by any party found to have been wrongfully enjoined or restrained”;²⁰³⁸ assuming a defendant is wrongfully enjoined, 28 U.S.C. § 1352 allows it to pursue an action to recover monetary relief in the amount of the bond. The law of virtually all states, including New York, is to similar effect.²⁰³⁹ The quantum of security necessary to support preliminary injunctions did not receive much judicial attention,²⁰⁴⁰ although an intermediate New York appellate court did hold that a trial court

²⁰³² See *Spin Master Ltd. v. Alan Yuan’s Store*, 325 F. Supp. 3d 413 (S.D.N.Y. 2018).

²⁰³³ Fed. R. Civ. P. 62(a).

²⁰³⁴ *Spin Master*, 325 F. Supp. 3d at 427.

²⁰³⁵ *Id.* at 428.

²⁰³⁶ See *Las Vegas Sands Corp. v. Fan Yu Ming*, 360 F. Supp. 3d 1072 (D. Nev. 2019).

²⁰³⁷ *Id.* at 1082.

²⁰³⁸ Fed. R. Civ. P. 65(c).

²⁰³⁹ See, e.g., N.Y. C.P.L.R. 6312(b) (McKinney 2008).

²⁰⁴⁰ See, e.g., *Las Vegas Sands Corp. v. Fan Yu Ming*, 360 F. Supp. 3d 1072, 1082 (D. Nev. 2019) (requiring, without explanation, \$100 bond to support preliminary injunction); *Mayson-Dixon Strategic Consulting, LLC v. Mason-Dixon Polling & Strategic Consulting, Inc.*, 324 F. Supp. 3d 569, 582 (D. Md. 2018) (requiring, without explanation, \$10,000 bond to support preliminary injunction).

had abused its discretion in requiring a plaintiff to post a bond of only \$15,000; as it explained, albeit without explanation of its rationale or discussion of the preliminary injunction record, “an undertaking in the sum of \$30,000 is appropriate under the circumstances.”²⁰⁴¹

An Ohio federal district court was more transparent in rejecting the request of a terminated restaurant franchisee for a bond in excess of \$300,000, which that defendant maintained was necessary to cover the costs associated with the potential closure of some of its locations.²⁰⁴² Based on the strength of the plaintiff’s case, the court found that “a bond in the modest amount of \$75,000” was appropriate.²⁰⁴³ The court then expressly advised the parties what it intended to do with the plaintiff’s bond when and if the bond arrived at the court:

The Clerk shall accept and deposit the bond into the registry of this Court. The Clerk shall promptly and properly invest those funds into Government Accounting Series securities through the Court Registry Investment System and deduct a registry fee as a percentage of the income earned on the investment over the period such sums remain deposited and invested, not to exceed ten percent (10%).²⁰⁴⁴

One court went so far as to set the security supporting a preliminary injunction at \$1,000,000.²⁰⁴⁵ The parties before that tribunal were competitors in the protein pancake mix market, and the plaintiff successfully had demonstrated that the defendants’ packaging infringed the trade dress of their own packaging. Although not expressly identifying the basis of its decision to require a seven-figure bond, the court appeared swayed by the defendants’ showing in the context of the balance-of-the-hardships inquiry. In particular, it found that:

Defendant has . . . presented evidence that it would incur substantial costs if it is forced to stop distribution of its current protein pancake mix packaging Defendant would incur direct costs related to any recall and product spoilage, would suffer damages to its hard-earned retailer relationships, could permanently lose valuable shelf space,

²⁰⁴¹ *Apple Air Conditioning & Appliance Serv., Inc. v. Apple Home Heating Corp.*, 1 N.Y.S.3d 581, 583 (N.Y. App. Div. 2018).

²⁰⁴² *See Marco’s Franchising, LLC v. Soham, Inc.*, 365 F. Supp. 3d 891 (N.D. Ohio 2019).

²⁰⁴³ *Id.* at 900.

²⁰⁴⁴ *Id.*

²⁰⁴⁵ *See Kodiak Cakes LLC v. Cont’l Mills, Inc.*, 358 F. Supp. 3d 1219 (D. Utah 2019).

²⁰⁴⁵ *Id.* at 1237.

and, as a result, could lose millions of dollars in future sales.²⁰⁴⁶

Rule 65(c) was not the only provision of federal law to produce a dispute over a security requirement. Instead, one reported opinion from the Court of International Trade addressed—and preliminarily enjoined—a determination by Customs and Border Protection that an importer must post a \$9 million single-entry bond based on CBP’s discovery of goods bearing counterfeit copies of federally registered marks in the importer’s shipments; by way of comparison, the agency previously had required a continuous bond of \$200,000 for all the importer’s annual shipments.²⁰⁴⁷ The court found testimony by the importer’s CEO of disruption to its supply chain, decreases in its wholesale business, revenues, and margins, and a forced reduction in its workforce convincing.²⁰⁴⁸ Based on CBP’s concession that only 1 percent of the goods in question bore spurious marks, it also found that CBP’s action “places an excessive burden on [the importer] and places it in an arguably impossible position that will likely cause the company to go out of business if it were to pay the enhanced bond.”²⁰⁴⁹ Under the circumstances, the importer was likely to prevail on its claim that the agency had violated the Administrative Procedure Act by acting in a manner that was “arbitrary, capricious, an abuse of discretion, or otherwise not in accordance with the law.”²⁰⁵⁰ The court therefore preliminarily enjoined further enforcement of the bond requirement.²⁰⁵¹

iv. Contempt

In a case presenting a less complex scenario, the Seventh Circuit affirmed a district court’s decision to hold a defendant in contempt of a prior consent judgment.²⁰⁵² Although defense counsel were served with a copy of the plaintiff’s motion accusing their clients of having violated the injunctive portions of the consent judgment, they failed to respond, apparently because the international travel of their local counsel distracted him from monitoring his e-mail. The defendants’ attorneys then added several feet to the depth of the hole into which they had dug their client by failing to appear at a hearing the district court scheduled on the plaintiff’s motion. On these facts, the appellate court had no difficulty determining that

²⁰⁴⁶ *Id.* at 1237.

²⁰⁴⁷ *See* U.S. Auto Parts Network, Inc. v. United States, 319 F. Supp. 3d 1303, 1306 (Ct. Int’l Trade 2018).

²⁰⁴⁸ *Id.* at 1307.

²⁰⁴⁹ *Id.* at 1310.

²⁰⁵⁰ *Id.* at 1309 (quoting 5 U.S.C. § 706(2)(A) (2012)).

²⁰⁵¹ *Id.* at 1311-12.

²⁰⁵² *See* Seventh Ave., Inc. v. Shaf Int’l, Inc., 909 F.3d 878 (7th Cir. 2018).

the district court had not abused its discretion by ordering the defendant to reimburse the plaintiff in attorneys' fees and taxable costs. In doing so, it rejected the defendant's argument that a belated response to the plaintiff's motion obviated the need for sanctions: "While the delayed response was surely better than not responding at all, the district court acted well within its discretion to find that [the defendant's] initial unresponsiveness warranted a sanction. . . . Deadlines matter."²⁰⁵³

b. Monetary Relief

i. Damages

(A) Actual Damages

(1) Eligibility of Prevailing Plaintiffs for Awards of Actual Damages

Few reported opinions addressed the eligibility of plaintiffs for awards of awards of actual damages; still, however, a California federal district court granted a defense motion for summary judgment on the issue.²⁰⁵⁴ As the court described its contents, that motion asserted that: "(1) [the plaintiff] did not identify any actual damages in its discovery responses or documents; (2) [the plaintiff's fact] witnesses were unable to identify any actual damages during their depositions; and (3) [the plaintiff's] own damages expert was unable to identify any evidence of actual damages."²⁰⁵⁵ Although the plaintiff responded to the motion by pointing to declaration and deposition testimony of alleged actual confusion caused by the defendants' conduct, the court found that testimony insufficiently detailed to create a genuine issue of material fact on the issue.²⁰⁵⁶ The plaintiff's claim for actual damages therefore did not survive until trial.

In contrast, another California federal district court declined to reach the same conclusion in a case in which the plaintiffs' claims asserted a persona-based cause of action under the law of that state.²⁰⁵⁷ In response to a defense motion for summary judgment, the plaintiffs successfully pointed to testimony by the individual plaintiff whose identity the defendants allegedly had misappropriated that he had received "hundreds of calls asking whether he had purchased [one of the defendants]";²⁰⁵⁸ moreover,

²⁰⁵³ *Id.* at 881.

²⁰⁵⁴ *See* Am. Auto. Ass'n of N. Cal., Nevada & Utah v. Gen. Motors LLC, 367 F. Supp. 3d 1072 (N.D. Cal. 2019).

²⁰⁵⁵ *Id.* at 1106.

²⁰⁵⁶ *Id.* at 1106-08.

²⁰⁵⁷ *See* Youngevity Int'l v. Smith, 350 F. Supp. 3d 919 (S.D. Cal. 2018).

²⁰⁵⁸ *Id.* at 923.

the same plaintiff testified that “the association greatly disturbed him because he has dedicated his career to improving public health, and believes that [the defendants’] products are very unhealthy and would not want consumers to believe he is endorsing those products.”²⁰⁵⁹ Finally, the plaintiffs benefitted from an expert report opining that the lead plaintiff had “failed to meet its projected revenue goals precisely during the time” of the defendants’ allegedly unlawful conduct.²⁰⁶⁰ The court therefore allowed the plaintiffs’ request for actual damages to proceed.

(2) Calculation of Actual Damages

Awards of actual damages to fund corrective advertising campaigns are rare, but one false advertising plaintiff successfully pursued such a remedy from a jury.²⁰⁶¹ Without success, the defendants objected to the award because the plaintiff had not engaged in any pretrial corrective advertising and because it had failed to adduce any evidence or testimony it would do so in the future. Reviewing the trial record, the court concluded that “[a]lthough [the plaintiff] did not introduce evidence at trial on any amount it would spend on corrective advertising in the future, there was no evidence that [the plaintiff] would not engage in corrective advertising.”²⁰⁶² The court did, however, credit the defendants’ challenge to the quantum of the jury’s award of \$925,617, which it found “punitive, instead of compensatory” in light of the \$1,318,023 the defendant had invested in the advertising found to be false.²⁰⁶³ It therefore exercised its discretion to conclude that “a corrective advertising award in the amount of twenty-five percent of [the defendant’s] advertising expenditures falls within the principles of equity in this case.”²⁰⁶⁴

A different court similarly undertook a remittitur of a jury’s award of actual damages in a false advertising action.²⁰⁶⁵ Although rejecting the defendants’ post-trial attacks on the jury’s finding of liability, the court accepted their argument that the plaintiff’s proof of actual or likely deception was limited to a survey conducted only among Utah residents. Because of the geographic limitations of that proof, the jury’s award—which rested on expert testimony of the alleged damages suffered by the plaintiff in Utah and seven other

²⁰⁵⁹ *Id.*

²⁰⁶⁰ *Id.*

²⁰⁶¹ See *Ill. Tool Works Inc. v. Rust-Oleum Corp.*, 346 F. Supp. 3d 951 (S.D. Tex. 2018), *appeal docketed*, No. 19-20210 (5th Cir. Apr. 4, 2019).

²⁰⁶² *Id.* at 959.

²⁰⁶³ *Id.* at 959-60.

²⁰⁶⁴ *Id.* at 960.

²⁰⁶⁵ See *Bimbo Bakeries USA, Inc. v. Sycamore*, 372 F. Supp. 3d 1291 (D. Utah 2019), *appeal docketed*, No. 19-4040 (10th Cir. Mar. 22, 2019).

states—could not stand. Instead, because the expert had failed to extrapolate his survey data to the other states, the plaintiff had failed to prove any damages outside Utah. That failure resulted in the court reducing the jury’s award of \$8,027,720 to a mere \$83,398.²⁰⁶⁶

A final notable reported opinion on the issue of actual damages excluded an expert’s report after dismantling it piece by piece.²⁰⁶⁷ The plaintiffs retaining the expert were automobile dealerships that objected to an automobile advertiser’s practice of falsely touting a “no haggling” and “no negotiation” experience for car buyers. The court identified multiple flaws in the expert’s methodology, the primary one of which was his failure to establish that “100% of sales made through [the defendant’s advertising service] were caused by advertisements that falsely promised a ‘no haggle’ experience.”²⁰⁶⁸ That failure was apparent on multiple levels because the expert had neglected to account for: (1) sales made through the marketing of the defendant’s “affinity partners”;²⁰⁶⁹ (2) sales made by dealers in the plaintiffs’ geographic markets that did not use the defendant’s services;²⁰⁷⁰ (3) sales made by the plaintiffs themselves while using the defendant’s services;²⁰⁷¹ and (4) variations in the profitability of individual sales that might render his use of a “single, across-the-board figure of \$1,602 in lost sales for each vehicle that went to a [defendant]-affiliated dealer rather than a plaintiff, whether an Audi sold in Massachusetts or a Hyundai sold in New Mexico.”²⁰⁷² The report’s unreliability therefore warranted its exclusion.

(B) Statutory Damages

If a defendant is found liable for counterfeiting, the prevailing plaintiff has the opportunity to elect, in lieu of an award of its actual damages or an accounting of the defendant’s profits, the statutory damages provided for under Section 35(c) of the Act: Such an award can be “not less than \$1,000 or more than \$200,000 per counterfeit mark per type of goods or services sold, offered for sale, or distributed, as the court considers just,” or, alternatively, “if the court finds that the use of the counterfeit mark was willful, not more than \$2,000,000 per counterfeit mark per type of goods or services sold, offered for sale, or distributed, as the court considers just.”²⁰⁷³

²⁰⁶⁶ *Id.* at 1306.

²⁰⁶⁷ *See* Dependable Sales & Serv., Inc. v. TrueCar, Inc., 311 F. Supp. 3d 653 (S.D.N.Y. 2018).

²⁰⁶⁸ *Id.* at 662.

²⁰⁶⁹ *Id.* at 662-63.

²⁰⁷⁰ *Id.* at 663.

²⁰⁷¹ *Id.* at 663-34.

²⁰⁷² *Id.* at 664.

²⁰⁷³ 15 U.S.C. § 1117(c) (2018).

Likewise, under Section 35(d),²⁰⁷⁴ a prevailing plaintiff in a cybersquatting action can elect to receive “an award of statutory damages in the amount of not less than \$1,000 and not more than \$100,000 per domain name, as the court considers just.”²⁰⁷⁵

The discretion accorded to district courts under these mechanisms led to varying results in cases in which prevailing plaintiffs sought awards of statutory damages.²⁰⁷⁶ One prevailing plaintiff secured the full amount of statutory damages it sought, in part by exercising some self-restraint in its request.²⁰⁷⁷ With the defendants having defaulted, the court concluded from the uncontested allegations in the complaint that “each Defendant promoted, distributed, advertised, offered for sale, and/or sold goods bearing marks which were in fact counterfeits of at least one of [Plaintiff’s] [m]arks”; moreover, “the allegations in the Complaint, which are taken as true, clearly establish Defendants intentionally copied [Plaintiff’s] [m]arks for the purpose of deriving the benefit of Plaintiff’s world-famous reputation.”²⁰⁷⁸ Under these circumstances, the court granted the plaintiff’s request for an award of \$1,000,000 per misappropriated mark on each type of good at issue, even though, as it observed, the facts alleged in the complaint might well have justified the maximum award of \$2,000,000 per mark per good. That amount, it found, “should be sufficient to deter Defendants and others from continuing to counterfeit or otherwise infringe Plaintiff’s trademarks, compensate Plaintiff, and punish Defendants, all stated goals of [Section 35(c)].”²⁰⁷⁹

Another prevailing plaintiff similarly went home with the statutory damages it requested against a group of adjudicated counterfeiters, again perhaps because of its restraint in calculating them.²⁰⁸⁰ In the absence of direct controlling authority from the Second Circuit, the New York federal district court hearing the case held on the plaintiff’s unopposed motion for summary judgment that it would apply the following factors from the copyright context:

- (i) “the expenses saved and the profits reaped”; (ii) “the revenues lost by the plaintiff”; (iii) “the value of the copyright”; (iv) “the deterrent effect on others besides the defendant”; (v) “whether the defendant’s conduct was innocent or willful”; (vi) “whether a defendant has cooperated

²⁰⁷⁴ *Id.* § 1117(d).

²⁰⁷⁵ *Id.*

²⁰⁷⁶ *See, e.g.,* John Wiley & Sons, Inc. v. Book Dog Books, LLC, 327 F. Supp. 3d 606, 634 (S.D.N.Y. 2018) (declining to disturb jury’s verdict of maximum \$2 million in statutory damages per mark infringed).

²⁰⁷⁷ *See* Chanel, Inc. v. Replicachanelbag, 362 F. Supp. 3d 1256 (S.D. Fla. 2019).

²⁰⁷⁸ *Id.* at 1265.

²⁰⁷⁹ *Id.* at 1265.

²⁰⁸⁰ *See* Spin Master Ltd. v. Alan Yuan’s Store, 325 F. Supp. 3d 413 (S.D.N.Y. 2018).

in providing particular records from which to assess the value of the infringing material produced”; and (vii) “the potential for discouraging the defendant.”²⁰⁸¹

Despite the absence of evidence or testimony bearing on the first and second factors, the court recognized “an inference of a broad scope of operations in cases dealing specifically with websites that ship and sell to a wide geographic range, such as the websites on which defendants operate in this case.”²⁰⁸² Moreover, it found, “[o]ther . . . factors weigh in favor of a relatively high statutory damages award. [The plaintiff’s] marks are valuable: its products are internationally recognized and highly coveted.”²⁰⁸³ These considerations led the court to agree with the plaintiff that “[a]n award of \$50,000 per defendant is appropriate and just, given that each defendant sold at least one infringing product.”²⁰⁸⁴

In a different case, one in which the precise quantum of statutory damages requested by the plaintiffs was undisclosed, many of the same considerations drove an award of \$300,000 per counterfeit mark per good sold by the lead defendant, leading to a total award of \$19,200,000.²⁰⁸⁵ Although the plaintiffs’ actual damages may have been low, the plaintiffs successfully established “the significant potential for damage to [their] goodwill and reputation through the dissemination of cheaply made, knockoff goods bearing offensive or mutilated settings of [their] trademarks—marks that [they have] developed and strengthened over decades of exposure and expenditure.”²⁰⁸⁶ Beyond that risk, the court found “deeply troubling” the lead defendant’s operation of “a business that facilitated blatant infringement of others’ intellectual property rights on the misguided notion that it was immune to liability as a ‘service provider’ that offered a notice-and-takedown

²⁰⁸¹ *Id.* at 425 (quoting *Fitzgerald Publ’g Co. v. Baylor Publ’g Co.*, 807 F.2d 1110, 1117 (2d Cir. 1986)).

²⁰⁸² *Id.* at 426.

²⁰⁸³ *Id.*

²⁰⁸⁴ *Id.*

The court did, however, refuse the plaintiff’s request for statutory damages under the Copyright Act as impermissibly duplicative:

[The plaintiff] acknowledges that no definitive authority in this Circuit supports an award of dual statutory damages for the same infringed product. Indeed, the weight of authority in this Circuit does not support such an award. The Second Circuit has repeatedly cautioned that, “[a] plaintiff seeking compensation for the same injury under different legal theories is of course only entitled to one recovery.”

Id. at 425 (quoting *Indu Craft, Inc. v. Bank of Baroda*, 47 F.3d 490, 497 (2d Cir. 1995)).

²⁰⁸⁵ See *H-D U.S.A., LLC v. SunFrog, LLC*, 311 F. Supp. 3d 1000 (E.D. Wis.), *appeal dismissed*, No. 18-2073, 2018 WL 6039900 (7th Cir. July 19, 2018).

²⁰⁸⁶ *Id.* at 1048.

procedure.”²⁰⁸⁷ And, if those things were insufficient justifications for a large award, the lead defendant “only begrudgingly dragged its feet down the path to compliance,” consequently “deserving of a sanction to deter it from continuing its business model and to discourage others from making similarly underprepared ventures.”²⁰⁸⁸ Finally, “[t]he public, too, would be served by a weighty damages award”²⁰⁸⁹ The court credited the lead defendant’s objections that it was not itself an actual counterfeiter—it merely sold unlawful goods online—and that the lead defendant had “made slow but significant progress in conforming its conduct to the requirements of the law”²⁰⁹⁰ as bases for not imposing the maximum possible award, but that was undoubtedly small consolation for that losing party.

Plaintiffs in the Northern District of Illinois also were less successful—at least relatively so—in securing the relief they sought. For example, one court in that district imposed a statutory damage award in the amount of \$500,000 after finding the defendants had used counterfeit imitations of the plaintiff’s certification marks on the defendants’ butane heaters.²⁰⁹¹ That award was informed by the \$381,000 to which the plaintiff would have been entitled had it sought a trebled accounting of the defendants’ profits. Although the plaintiff therefore received an augmented recovery, the court did not accept the plaintiff’s invitation to impose an award of \$1,000,000. As it explained, “[t]his is well short of [the plaintiff’s] proposal but strikes the appropriate balance of the equities,” especially because the defendants had discontinued their unlawful conduct, something that rendered the deterrent effect of a larger award moot.²⁰⁹²

Liability for counterfeiting as a matter of law similarly failed to produce the requested award of statutory damages in a case from the same district.²⁰⁹³ The registered mark at issue consisted of the shape of a cookie cutter, the intentional copying of which was not seriously disputed. Noting the wide discretion it enjoyed in setting the quantum of statutory damages, the court identified a number of relevant factors to govern its resolution of the issue. Those included: (1) the value of the plaintiff’s brand; (2) the harm to that value occasioned by the defendants’ conduct; and (3) the defendants’ participation in the action (as opposed to defaulting in response to the plaintiff’s complaint). Relying primarily on the small scale of the defendants’ operations, the court declined to award the \$100,000 in

²⁰⁸⁷ *Id.*

²⁰⁸⁸ *Id.* at 1049.

²⁰⁸⁹ *Id.*

²⁰⁹⁰ *Id.*

²⁰⁹¹ See *UL LLC v. Am. Energy Prods., LLC*, 358 F. Supp. 3d 753 (N.D. Ill. 2019).

²⁰⁹² *Id.* at 761.

²⁰⁹³ See *Entm’t One UK Ltd. v. 2012Shiliang*, 384 F. Supp. 3d 941 (N.D. Ill. 2019).

statutory damages per defendant requested by the plaintiff, choosing instead to impose only half that amount.²⁰⁹⁴

ii. Accountings of Profits

(A) Eligibility of Prevailing Plaintiffs for Accountings of Profits

In keeping with recent increased involvement by the Supreme Court in trademark and unfair competition litigation, the Court agreed in *Romag Fasteners, Inc. v. Fossil, Inc.*²⁰⁹⁵ to hear (and hopefully resolve) a question that has split the Circuits for years. As articulated by the petitioner in that action, that question was “[w]hether, under section 35 of the Lanham Act, willful infringement is a prerequisite for an award of an infringer’s profits for a violation of section 43(a).”²⁰⁹⁶

One possible answer to that question is the traditional rule that willfulness is always a necessary prerequisite for an accounting.²⁰⁹⁷ An example of that rule came in *Romag* itself in an application of Second Circuit law by the Federal Circuit, which required a showing of willfulness and denied an accounting when the prevailing plaintiff failed to make it.²⁰⁹⁸ Another came at the hands of the Eighth Circuit, which declined to overturn a jury’s finding that the infringing defendants *had* acted willfully and that the prevailing plaintiff therefore deserved the accounting it sought.²⁰⁹⁹

²⁰⁹⁴ *Id.* at 952-53.

²⁰⁹⁵ 139 S. Ct. 2778 (2019) (granting cert.).

²⁰⁹⁶ Petition for Writ of Certiorari, *Romag Fasteners, Inc. v. Fossil, Inc.*, 139 S. Ct. 2778 (2019), 2019 WL 1317084, 2019 WL 1327062, at *i (U.S. June 28, 2019).

²⁰⁹⁷ *See, e.g.*, *Am. Auto. Ass’n of N. Cal., Nevada & Utah v. Gen. Motors LLC*, 367 F. Supp. 3d 1072, 1104-05 (N.D. Cal. 2019) (granting defense motion for summary judgment after concluding that no reasonable jury could find that defendants had willfully infringed plaintiff’s mark); *Toyo Tire & Rubber Co. v. Doublestar Dong Feng Tyre Co.*, 128 U.S.P.Q.2d 1472 (C.D. Cal. 2018).

²⁰⁹⁸ *See Romag Fasteners, Inc. v. Fossil, Inc.*, No. 2018-2417, 2019 WL 2677388, at *1 (Fed. Cir. Feb. 5, 2019), *cert. granted*, 139 S. Ct. 2778 (2019).

²⁰⁹⁹ *See Sturgis Motorcycle Rally, Inc. v. Rushmore Photo & Gifts, Inc.*, 908 F.3d 313, 339 (8th Cir. 2018), *on remand*, 129 U.S.P.Q.2d 1392 (D.S.D. 2019). The plaintiff’s mark was a composite one featuring the words “BLACK HILLS MOTOR CLASSIC,” “STURGIS,” and “RALLY & RACES BLACK HILLS S.D.,” along stylized designs of an eagle, stars, motorcycles, bison, and feathers and registered for “promoting sports competitions and/or events of others, namely motorcycle rallies, exhibits and competitions; and promoting economic development in the city of Sturgis and the Black Hills area of South Dakota and Wyoming.” In affirming the finding of willfulness below, the Eighth Circuit noted evidence in the trial record of the mark’s widespread use and public recognition, of the defendant’s knowledge of the plaintiff’s rights, and of the similarity between the plaintiff’s registered mark and a design the defendants had affixed to shot glasses. Of equal significance, the court observed, “[t]he [defendants’] glass also states, ‘Genuine Article-Accept No Substitutes,’ from which the jury could infer that [the defendants] consciously intended consumers to confuse the dominant design on the glass with the closely similar ‘official’ . . . mark [owned by the plaintiff].” *Id.* at 339.

Another possible option, one also reflected in reported opinions over the past year is that, although the degree of a defendants' willfulness can inform the inquiry into whether an accounting is appropriate, willfulness should not perform a gatekeeping function. Courts applying this rule often base it on a 1999 amendment to Section 35(a) of the Lanham Act²¹⁰⁰ in which Congress revised that statute to provide as follows:

When a violation of [Section 32], a violation under [Section 43(a) or Section 43(d)], *or a willful violation under [Section 43(c)]*, shall have been established in any civil action arising under this chapter, the plaintiff shall be entitled, subject to the provisions of [Sections 29 and 32], and subject to the principles of equity, to recover (1) defendant's profits, (2) any damages sustained by the plaintiff, and (3) the costs of the action.²¹⁰¹

The addition of the italicized language quoted above has led some courts to conclude that Congress intended to set up a two-tiered test for monetary relief, including accountings, namely: (1) a showing of willfulness is necessary for an accounting arising from violations of Section 43(c); but (2) such a showing is not a prerequisite for an accounting where violations of Sections 32, 43(a), or Section 43(d) are concerned.

One court taking that approach was the Fifth Circuit.²¹⁰² Rather than according dispositive significance to the willfulness of the defendant before it, that court considered the defendant's scienter only one of six nonexclusive factors, namely:

(1) whether the defendant had the intent to confuse or deceive, (2) whether sales have been diverted, (3) the adequacy of other remedies, (4) any unreasonable delay by the plaintiff in asserting his rights, (5) the public interest in making the misconduct unprofitable, and (6) whether it is a case of palming off.²¹⁰³

In an earlier appeal in the same case, the court had declined to disturb a finding that at least some portion of the defendant's profits were attributable to the defendant's false advertising. Nevertheless, that finding did not necessarily establish that the second factor, that of diverted sales, favored the plaintiffs. Instead:

[T]he attribution and diversion inquiries serve different functions in assessing the propriety of disgorgement. The

²¹⁰⁰ 15 U.S.C. § 1117(a) (2018).

²¹⁰¹ *Id.* (emphasis added).

²¹⁰² See *Retractable Techs., Inc. v. Becton Dickinson & Co.*, 919 F.3d 869 (5th Cir. 2019).

²¹⁰³ *Id.* at 876 (quoting *Pebble Beach Co. v. Tour 18 I Ltd.*, 155 F.3d 526, 554 (5th Cir. 1998), *abrogated on other grounds by* *TraFFix Devices, Inc. v. Mktg. Displays, Inc.*, 532 U.S. 23 (2001)).

“diversion” factor plays an important role in establishing the *plaintiff’s* entitlement to profits. In many cases, disgorgement will not be equitable where few or no sales were ever diverted from the plaintiff to the defendant, because disgorgement in such contexts would grant the plaintiff an unjustified “windfall.” The “attribution” requirement ensures that once the district court has determined disgorgement is equitable, a *defendant* will only be forced to disgorge profits attributable to the Lanham Act violation.²¹⁰⁴

Because the parties were not the primary players in the marketplace, the court rejected the argument that the plaintiffs had been presumptively damaged,²¹⁰⁵ and the factual record otherwise failed to demonstrate anything more than a “speculative and attenuated” relationship between the defendant’s conducted and any sales diverted from the plaintiffs.²¹⁰⁶ Moreover, the district court had properly found that “injunctive relief was sufficient and monetary relief would grant [the defendants] an unjustified windfall”²¹⁰⁷ The district court therefore had not erred in declining to order an accounting.

²¹⁰⁴ *Id.* at 878.

²¹⁰⁵ As the court explained:

[The plaintiff] suggests that the district court on remand should have presumed diversion of sales because [the defendant] engaged in intentionally deceptive comparative advertising. While some of our fellow circuits have applied this presumption to claims for disgorgement in false advertising cases, they have largely done so in cases of intentionally false comparative advertising “where [it is] reasonable to presume that every dollar defendant makes has come directly out of [the] plaintiff’s pocket.” We need not decide the wisdom of this presumption in such cases, because it does not apply here. From the beginning, the district court recognized that [the plaintiff] and [the defendant] were not the only players in the [relevant] market and that it could not presume that any benefit [the defendant] gained from its false advertising came directly at the expense of [the plaintiff]. The district court therefore did not err in looking for more concrete evidence of diversion.

Id. at 880 (third and fourth alterations in original) (footnotes omitted) (quoting *TrafficSchool.com, Inc. v. Edriver Inc.*, 653 F.3d 820, 831 (9th Cir. 2011)).

²¹⁰⁶ *Id.* at 879-81.

In reaching this conclusion, the court rejected the plaintiffs’ challenge to the district court’s finding that the sixth relevant factor, namely, whether the defendant had palmed off its goods as those of the plaintiff, favored the defendant. The plaintiffs argued that this factor should not receive any weight in false advertising actions such as the one they had brought. In particular, they asserted that “in lieu of palming off, the district court should have accounted for the loss of goodwill [the plaintiffs] experienced as a result of the false advertising.” *Id.* at 882. Although acknowledging that the plaintiffs might be correct in principle, the court affirmed the district court’s finding that the plaintiffs had failed to demonstrate as a factual matter that they had suffered any such loss. *Id.* at 882. In fact, the appellate court pointed out, “[the plaintiffs] market share . . . increased and its sales nearly doubled over the relative period of [the defendant’s] false advertising.” *Id.*

²¹⁰⁷ *Id.* at 883.

In a final appellate opinion demonstrating the split in the circuits on the issue, the Eleventh Circuit offered up three possible justifications for accountings of profits, only the first of which turned on a showing of willfulness: “An accounting of a defendant’s profits is appropriate where: (1) the defendant’s conduct was willful and deliberate, (2) the defendant was unjustly enriched, or (3) it is necessary to deter future conduct.”²¹⁰⁸ It did so in an appeal from a finding that the defendant’s infringement had indeed been willful based solely on the defendant’s continued use of its mark after receiving notice of the plaintiff’s objections. The appellate court vacated that conclusion, holding:

[W]hen it received [the plaintiff’s] complaint, [the defendant] had a valid registered trademark [The plaintiff] did not obtain a preliminary injunction, and at the time, no court had adjudicated whether [the defendant] was infringing on [the plaintiff’s] trademark.

Under the district court’s construction of willfulness, a valid trademark holder risks losing all of its profits if it does not immediately cease selling its trademarked product upon receiving a complaint indicating it may be violating the law. The district court determined that at the time [the defendant] obtained its trademark, [the defendant] did not intend to infringe on [the plaintiff’s] trademark. And from the time [the defendant] obtained its trademark to the time the district court made its final determination, there was no further adjudication that [the defendant] was infringing. This continued sale under the color of a valid federal trademark cannot alone establish willfulness.²¹⁰⁹

At the trial court level, a Texas federal district court applied the Fifth Circuit’s six-part test for evaluating the propriety of an accounting to sustain a jury’s finding that the prevailing plaintiff in the case before the court was entitled to recover the defendants’ profits.²¹¹⁰ One basis of the court’s decision to do so was the jury’s finding that the defendants had “acted maliciously, fraudulently, deliberately, or willfully.”²¹¹¹ Likewise, the “strong public interest in making false advertising unprofitable” and the timeliness of the plaintiff’s challenge to the defendants’ conduct also favored an accounting.²¹¹² Although the plaintiff failed to demonstrate the false advertising in question diverted sales to the defendants, that failure

²¹⁰⁸ *PlayNation Play Sys., Inc. v. Velez Corp.*, 924 F.3d 1159, 1170 (11th Cir. 2019).

²¹⁰⁹ *Id.* at 1170.

²¹¹⁰ *See Ill. Tool Works Inc. v. Rust-Oleum Corp.*, 346 F. Supp. 3d 951 (S.D. Tex. 2018), *appeal docketed*, No. 19-20210 (5th Cir. Apr. 4, 2019).

²¹¹¹ *Id.* at 959.

²¹¹² *Id.*

did not warrant disturbing the jury's verdict, especially because the permanent injunction entered by the court was "inadequate to remedy any past harm [the plaintiff] suffered as a result of the [false advertising]." ²¹¹³

Similarly, a Minnesota federal district court invoked the Eighth Circuit rule that "[i]n cases of deliberate infringement, 'an accounting of profits may be based upon 1) unjust enrichment, 2) damages, or 3) deterrence of a willful infringer.'" ²¹¹⁴ It disposed of the first two potential rationales with the explanation that "the Court's finding . . .—that confusion, while likely, was nonetheless probably minimal—strongly suggests there was no unjust enrichment or damages, and [the plaintiffs] advance[] no evidence or argument to the contrary." ²¹¹⁵ It then found the goal of deterrence an insufficient justification for an accounting because the defendants' conduct had been motivated by an apparently genuine belief that they owned the disputed marks and a desire to retaliate against what they regarded as the plaintiffs' infringement of their rights: Although the Court obviously cannot and does not condone such retaliation, it nonetheless concludes that an injunction is sufficient to deter [the defendants] from future infringement of [the plaintiffs'] marks." ²¹¹⁶

A final reported opinion addressing the eligibility of a prevailing plaintiff to an accounting of profits ²¹¹⁷ focused on the significance to the inquiry of Section 29, which provides in relevant part that "in any suit for infringement under this chapter by . . . a registrant failing to give . . . notice of [its] registration, no profits and no damages shall be recovered under the provisions of this chapter unless the defendant had actual notice of the registration." ²¹¹⁸ With the court having found them liable as a matter of law for infringement and likely dilution, the defendants attempted to escape an accounting by arguing in their own summary judgment motion that, in light of the lead plaintiff's failure to use the ® symbol in conjunction with its registered marks, they were unaware the marks were registered until served with the plaintiffs' complaint. The lead plaintiff did not contest that failure, but it pointed to rulings against the defendants by Italian courts in related litigation between the parties, as well as cease-and-desist letters it had sent

²¹¹³ *Id.*

²¹¹⁴ *Safeway Transit LLC v. Disc. Party Bus, Inc.*, 334 F. Supp. 3d 995, 1007 (D. Minn. 2018) (quoting *Minn. Pet Breeders, Inc. v. Schell & Kampeter, Inc.*, 41 F.3d 1242, 1247 (8th Cir. 1994)), *appeal docketed*, No. 18-2990 (8th Cir. Sept. 17, 2018).

²¹¹⁵ *Id.* at 1008.

²¹¹⁶ *Id.*

²¹¹⁷ *See Gianni Versace, S.p.A. v. Versace 19.69 Abbigliamento Sportivo SRL*, 328 F. Supp. 3d 1007 (N.D. Cal. 2018), *appeal dismissed*, No. 19-15188, 2019 WL 2005744 (9th Cir. Apr. 17, 2019).

²¹¹⁸ 15 U.S.C. § 1111 (2018).

to the defendants and the defendants' agreement to indemnify their licensees if the plaintiffs sued them in addition to the defendants themselves. Based on those showings, the court concluded, a reasonable factfinder could find the defendants were on notice of the lead plaintiff's registrations prior to the initiation of the lawsuit.²¹¹⁹

(B) The Accounting Process

Section 35(a) provides “[i]n assessing profits the plaintiff shall be required to prove defendant’s sales only; [the] defendant must prove all elements of cost or deduction claimed.”²¹²⁰ In applying this rule in cases in which an accounting is sought, the Seventh Circuit has in the past clearly distinguished between that equitable remedy, on the one hand, and the legal remedy of an award of actual damages, on the other hand.²¹²¹ Nevertheless, it fell victim to the all-too-common tendency among courts and litigants alike to refer to the outcome of an accounting as a “damages award.”²¹²² It did so in a case in which the jury undertaking the inquiry had received the following instruction from the district court:

Each defendant bears the burden of proving the direct expenses that it incurred in producing, marketing, and selling the products at issue. If a defendant fails to prove such direct expenses, you must find the amount of its gross revenues as the amount of profits.²¹²³

Because the only defendant found liable for infringement apparently failed to adduce evidence or testimony of permissible deductions from its overall revenues, the plaintiff recovered the entirety of those revenues.²¹²⁴

That opinion was not the only one to conflate the separate remedies of accountings of profits and awards of damages but still to apply the proper methodology when addressing the former.²¹²⁵ The court issuing it began in unpromising fashion by addressing the issue under a heading reading “Damages,” but it soon got on track. Although the court found that the defendants had acted willfully and that an accounting therefore was appropriate under Ninth Circuit authority, the defendants declined to participate fully in discovery concerning their overall revenues. Based on that

²¹¹⁹ *Gianni Versace, S.p.A.*, 328 F. Supp. 3d at 1030.

²¹²⁰ 15 U.S.C. § 1117(a) (2018).

²¹²¹ *See generally* *WMS Gaming Inc. v. WPC Prods. Ltd.*, 542 F.3d 601 (7th Cir. 2008).

²¹²² *See* *Barrington Music Prods., Inc. v. Music & Arts Ctr.*, 924 F.3d 966, 968 (7th Cir. 2019).

²¹²³ *Id.*

²¹²⁴ *Id.*

²¹²⁵ *See* *AECOM Energy & Constr., Inc. v. Ripley*, 348 F. Supp. 3d 1038 (C.D. Cal. 2018), *reconsideration denied*, No. CV 17-5398-RSWL-SSx, 2019 WL 2610953 (C.D. Cal. Apr. 24, 2019), *appeal docketed*, No. 19-55588 (9th Cir. May 23, 2019).

circumstance, the court found the plaintiff was justified in relying on three ambitious press releases by the defendants in which they claimed \$1.806 billion in revenue. The court therefore undertook an accounting based on that threshold number, eventually ordering the disgorgement of a figure redacted from its opinion, but which was based on the plaintiff's acceptance of the figures in a two-page summary of claimed costs and deductions belatedly produced by the defendants.²¹²⁶ As the court pointed out, “[g]iven Defendants’ failure to comply throughout discovery and failure to raise a genuine issue as to damages, Plaintiff has met its burden of establishing Defendants’ revenue. Without any argument or evidence provided by Defendant as to costs, the Court accepts Plaintiff’s calculation for the total profits”²¹²⁷

Likewise, a different court declined to disturb a jury’s finding that infringement by a trio of defendants had generated awardable profits in an amount of \$710,261.00.²¹²⁸ The court did not discuss in detail the evidentiary showings supporting that figure beyond citing testimony by one of the defendants that “Defendants were making \$1,000.00 in daily revenue, which he later increased to between \$1,000.00 and \$1,500.00 per day.”²¹²⁹ Because that revenue stream would have generated \$1.3 million during the period of infringement, “the jury’s determination was . . . a rough calculation of the profits, and is well below Plaintiff’s request.”²¹³⁰

Another notable opinion addressing the proper mechanics of an accounting under Section 35(a) confirmed that the nonprofit status of the parties does not necessitate a change to the usual methodology.²¹³¹ As the court summarized the theory of relief of the plaintiffs before it, “because the parties are non-profit organizations, rather than ‘profits’ calculated in the traditional accounting sense of ‘revenue minus expenses,’ plaintiffs seek defendants’ total gross revenue from dues and loan payments [during the period of infringement].”²¹³² The court agreed with the plaintiffs’ proposed approach, holding that “[g]iven that local chapters pay dues on an annual basis, plaintiffs are entitled to those revenues they would have received but for defendants’ wrongful

²¹²⁶ *Id.* at 1064-65.

²¹²⁷ *Id.* at 1065.

²¹²⁸ *See* Talent Mobile Dev., Inc. v. Headios Grp., 382 F. Supp. 3d 953 (C.D. Cal. 2019), *appeal docketed*, No. 19-55258 (9th Cir. Mar. 5, 2019).

²¹²⁹ *Id.* at 963.

²¹³⁰ *Id.*

²¹³¹ *See* Nat’l Grange of the Order of Patrons of Husbandry v. Cal. Guild, 334 F. Supp. 3d 1057 (E.D. Cal.), *reconsideration denied sub nom.* Nat’l Grange v. Cal. Guild, No. 2:16-cv-0201 WBS DB, 2018 WL 5270563 (E.D. Cal. Oct. 22, 2018), *appeal docketed*, No. 18-16671 (9th Cir. Sept. 5, 2018).

²¹³² *Id.* at 1069.

actions.”²¹³³ Nevertheless, and apparently because the parties agreed it was the proper procedure, the court ultimately referred the actual accounting to the jury.²¹³⁴

Finally, a California appellate opinion demonstrated that, whatever burden-shifting effect Section 35(a) might have, the same is not necessarily true under the California statute authorizing accountings for violations of prevailing plaintiffs’ rights of publicity.²¹³⁵ In contrast to Section 35(a), that statute provides that “[i]n establishing [the defendant’s] profits, the injured party or parties are required to present proof only of the gross revenue *attributable to such use*, and the person who violated this section is required to prove his or her deductible expenses.”²¹³⁶ Having failed to secure a jury instruction to the effect that the defendant was responsible for proving the portion of its revenues attributable to sources other than the defendant’s unlawful use of his image, the plaintiff invoked Section 35(a) on appeal, but to no avail. Noting that “[s]tate courts of appeal will resort to federal law for guidance only in the absence of relevant state precedent,”²¹³⁷ the court found that the statute “could not be clearer as to which party bears the burden to prove [the defendant’s] profits attributable to the unauthorized use of [the plaintiff’s] image. Accordingly, we need not turn to any extrinsic sources on this point.”²¹³⁸

The remainder of the court’s opinion was equally favorable to the defendant. To carry his burden of apportionment before the trial court, the plaintiff had retained an expert witness who opined that 1 to 3 percent of the defendant’s overall revenue was attributable to the plaintiff’s appearance in the defendant’s advertising. The trial court excluded the expert’s opinion, however, and the appellate court affirmed. As the latter explained after reviewing the plaintiff’s career as a model, actor, and professional volleyball player:

[The expert] based his opinion on a comparison of royalty agreements with various celebrities, athletes, and other persons of international prominence. These included Joe Namath, George Foreman, Kathy Ireland, Paris Hilton, Barry Bonds, Michael Jordan, Evander Holyfield, Tim Duncan, John Elway, Alex Rodriguez and Tyra Banks. Intending no disrespect to [the plaintiff], nothing in the appellate record indicates that he shared anywhere near the

²¹³³ *Id.*

²¹³⁴ *Id.* at 1070.

²¹³⁵ See *Olive v. Gen. Nutrition Ctrs., Inc.*, 242 Cal. Rptr. 3d 15 (Ct. App. 2018), *reh’g denied* (Jan. 23, 2019), *review denied* (Apr. 17, 2019).

²¹³⁶ Cal. Civil Code § 3344(a) (West 2017) (emphasis added).

²¹³⁷ *Olive*, 242 Cal. Rptr. 3d at 23.

²¹³⁸ *Id.*

same degree of celebrity as those included in [the expert's] sample.²¹³⁹

That was not the only flaw in the expert's methodology, however, for the court also faulted him for "compar[ing] the limited use of [the plaintiff's] image from one photo shoot to comprehensive royalty agreements that included the licensors' name, signature, voice, initials, endorsement, and copyrights."²¹⁴⁰ Finally, although the expert based his opinion in part on alleged testimony by the defendant's president and CEO that the plaintiff's image had driven 1 percent of the defendant's revenue, the actual testimony in question read, "it has the least amount of value of anything I've told you in regards to whether a consumer buys a product. . . . "I can put it at anywhere from zero to slightly more than zero. Very little. . . . I'll go zero to one."²¹⁴¹ Of equal significance, the expert had assumed a causal connection between growth in the defendant's sales and the use of the plaintiff's image in the advertising when, in fact, other considerations might have come into play.²¹⁴² The trial court therefore had properly excluded the testimony of that witness, and additionally, the testimony of another witness based on that of the first.²¹⁴³

iii. Adjustments of Awards of Damages and Accountings of Profits

Section 35 contains several provisions authorizing adjustments to an award of a plaintiff's actual damages or a defendant's profits. To begin with, Section 35(a) provides, "[i]n assessing damages the court may enter judgment, according to the circumstances of the case, for any sum above the amount found as actual damages, not exceeding three times such amount";²¹⁴⁴ the same provision also recites, "[i]f the court shall find that the amount of the recovery based on profits is either inadequate or excessive the court may in

²¹³⁹ *Id.* at 26.

²¹⁴⁰ *Id.*

²¹⁴¹ *Id.*

²¹⁴² *Id.* at 27. According to the court:

[The expert] found a causal connection between [the defendant's] annual growth rate and its unauthorized use of [the plaintiff's] image without identifying any reliable evidence linking the two, such as data from a focus group. [The expert's] analysis did not consider the macroeconomic conditions during the relevant period of time, [the defendant's] pricing promotions, general sales in the vitamin and supplement industry, employee sales promotions, [the defendant's] other marketing efforts, and the impact of professional athletic "ambassadors" used by [the defendant]. [The defendant's] conclusory analysis was therefore unduly speculative.

Id.

²¹⁴³ *Id.* at 27-28.

²¹⁴⁴ 15 U.S.C. § 1117(a) (2018).

its discretion enter judgment for such sum as the court shall find to be just, according to the circumstances of the case.”²¹⁴⁵ Likewise, Section 35(b) provides for enhancements in cases in which a defendant has been found liable for having trafficked in goods or services associated with counterfeit marks:

In assessing damages . . . in a case involving use of a counterfeit mark . . . , the court shall, unless the court finds extenuating circumstances, enter judgment for three times such profits or damages, whichever amount is greater, together with a reasonable attorney’s fee, if the violation consists of

- (1) intentionally using a mark or designation, knowing such mark or designation is a counterfeit mark . . . , in connection with the sale, offering for sale, or distribution of goods or services; or
- (2) providing goods or services necessary to the commission of a violation specified in paragraph (1), with the intent that the recipient of the goods or services would put the goods or services to use in committing the violation.²¹⁴⁶

One court chose to augment the results of an accounting under Section 35(a) by ordering it trebled even before the accounting was undertaken by a jury.²¹⁴⁷ The court did so in a case in which, having been terminated as a state chapter of a national farmers’ organization, the lead defendant undertook a number of actions apparently calculated to create the impression it remained an affiliate in good standing. Citing prior authority authorizing equitable increases in monetary relief based on similar facts, the court concluded that “enhanced damages [sic] [could] account for the willfulness of defendants’ conduct.”²¹⁴⁸ Without apparent consideration of whether a mere doubling of the accounting might suffice, the court settled in advance on a trebling.

In contrast, a different court declined to grant a prevailing plaintiff’s request for an augmented accounting of the defendants’ profits.²¹⁴⁹ Prior to doing so, the court identified the considerations relevant to the issue, which included: (1) the defendants’ intent to deceive; (2) the diversion of any sales; (3) the adequacy of other remedies; (4) delay by the plaintiff in asserting its rights; (5) the

²¹⁴⁵ *Id.*

²¹⁴⁶ *Id.* § 1117(b).

²¹⁴⁷ See *Nat’l Grange of the Order of Patrons of Husbandry v. Cal. Guild*, 334 F. Supp. 3d 1057, 1070 (E.D. Cal. 2018), *reconsideration denied sub nom.* *Nat’l Grange v. Cal. Guild*, No. 2:16-cv-0201 WBS DB, 2018 WL 5270563 (E.D. Cal. Oct. 22, 2018), *appeal docketed*, No. 18-16671 (9th Cir. Sept. 5, 2018).

²¹⁴⁸ *Id.* at 1070.

²¹⁴⁹ See *Evoqua Water Techs. LLC v. M.W. Watermark, LLC*, 128 U.S.P.Q.2d 1775 (W.D. Mich. 2018).

public interest in making defendants' the misconduct unprofitable; and(6) "palming off," i.e., whether the defendant used its infringement of the plaintiff's mark to sell its own products to the public through misrepresentation."²¹⁵⁰ It then held the plaintiff's request was unjustified under an application of those factors: "Here, there is no evidence that Defendants intended to deceive, that [Plaintiff's] sales were diverted, or that Defendants used [Plaintiff's] marks to sell their own products through misrepresentation. Moreover, the jury determined that any infringement was not willful. Thus, [Plaintiff's] request for enhanced damages [sic] is denied."²¹⁵¹

iv. Prejudgment and Post-Judgment Interest

On its face, Section 35 of the Lanham Act expressly authorizes prejudgment interest only in cases in which a defendant has willfully engaged in counterfeiting.²¹⁵² Nevertheless, as one opinion recognized, "[c]ourts award prejudgment interest in Lanham Act cases where 'but for' the wrongful conduct, the plaintiff would have had the damages amount to invest."²¹⁵³ In an application of that standard, the court issuing that opinion noted that "[t]he jury awarded [the plaintiff] . . . disgorgement of [the defendants'] profits and [an award of damages to fund] prospective corrective advertising. It is undisputed [the plaintiff] was not awarded damages for any amount of lost profits or money [the plaintiff] already spent on corrective advertising."²¹⁵⁴ An award of prejudgment interest therefore was inappropriate, even if the plaintiff did receive *post*-judgment interest at a rate of 2.66 percent under 28 U.S.C. § 1961, which provides that "[i]nterest shall be allowed on any money judgment in a civil case recovered in a district court" and "such interest shall be calculated from the date of entry of the judgment."²¹⁵⁵

v. Attorneys' Fees

Trial courts enjoy the discretion to award attorneys' fees under a number of mechanisms to prevailing parties in trademark and

²¹⁵⁰ *Id.* at 1783.

²¹⁵¹ *Id.*

²¹⁵² 15 U.S.C. § 1117(b) (2018).

²¹⁵³ *See* Ill. Tool Works Inc. v. Rust-Oleum Corp., 346 F. Supp. 3d 951, 960 (S.D. Tex. 2018), *appeal docketed*, No. 19-20210 (5th Cir. Apr. 4, 2019).

²¹⁵⁴ *Id.*

²¹⁵⁵ 28 U.S.C. § 1961(a) (2018).

For an additional opinion awarding post-judgment interest under Section 1961(a), albeit without an extended discussion of the issue, see *Spin Master Ltd. v. Alan Yuan's Store*, 325 F. Supp. 3d 413, 426 (S.D.N.Y. 2018).

unfair competition litigation. Those parties in some jurisdictions can secure awards of fees under state law,²¹⁵⁶ but, as always, most cases awarding fees over the past year did so under federal law, which recognizes several bases for fee petitions. For example, and of perhaps greatest familiarity to trademark practitioners, Section 35(a) authorizes the imposition of fees upon the losing party in “exceptional cases,”²¹⁵⁷ while Section 35(b) makes such an award virtually mandatory in cases in which a defendant has been found liable for trafficking in goods or services associated with counterfeit marks.²¹⁵⁸ The Federal Rules of Appellate Procedure authorize awards of fees to reimburse the expenses of frivolous appeals,²¹⁵⁹ and federal district courts also may award fees if a litigant has “unreasonably and vexatiously” multiplied the proceedings in a case.²¹⁶⁰ Federal courts likewise have the inherent power to award fees if bad-faith litigation practices by the parties or other considerations justify them and also may impose awards of fees as sanctions for contempt, under Rules 11 and 41(d) of the Federal Rules of Civil Procedure,²¹⁶¹ or, in the case of discovery violations, under Rule 37.²¹⁶² Finally, Section 21(b)(3) of the Act²¹⁶³ provides for an automatic award of the USPTO’s reasonable “expenses,” if an unsuccessful ex parte appeal from a Trademark Trial and Appeal Board decision is taken to the U.S. District Court for the Eastern District of Virginia, a provision the Fourth Circuit has held includes the Office’s attorneys’ fees and paralegal costs;²¹⁶⁴ that interpretation, however, is almost certainly now bad law in light of the Supreme Court’s rejection in *Peter v. Nantkwest, Inc.*,²¹⁶⁵ of automatic fee awards under the substantively worded Section 145 of the Patent Act.²¹⁶⁶

²¹⁵⁶ See, e.g., *Denali Real Estate, LLC v. Denali Custom Builders, Inc.*, 926 N.W.2d 610, 626 (Neb. 2019) (affirming, without extensive discussion, award of attorneys’ fees to prevailing plaintiff under Nebraska law).

²¹⁵⁷ 15 U.S.C. § 1117(a) (2018).

²¹⁵⁸ *Id.* § 1117(b).

²¹⁵⁹ Fed. R. App. P. 38.

²¹⁶⁰ 28 U.S.C. § 1927 (2018).

²¹⁶¹ Fed. R. Civ. P. 11 & 41(d).

²¹⁶² Fed. R. Civ. P. 37.

²¹⁶³ 15 U.S.C. § 1071(b)(3) (2018).

²¹⁶⁴ See *Booking.com B.V. v. U.S. Patent & Trademark Office*, 915 F.3d 171, 187–88 (4th Cir.), as amended (Feb. 27, 2019), cert. granted, No. 19-46, 2019 WL 5850636 (U.S. Nov. 11, 2019); *Shammas v. Focarino*, 784 F.3d 219, 222-27 (4th Cir. 2015).

²¹⁶⁵ 140 S. Ct. 365 (2019).

²¹⁶⁶ 25 U.S.C. § 145 (2018).

(A) Determination of the Prevailing Party

When a pair of plaintiffs lost their infringement action, the defendants successfully pursued an award of their fees from a New York federal district court under Section 35(a).²¹⁶⁷ But the defendants had prevailed not on the merits of the plaintiffs' claims but instead because those claims were barred by issue preclusion, and that led the defendants to challenge the award on the theory that the plaintiffs were not, in fact, prevailing parties. That theory met with misfortune on appeal to the Second Circuit, which rejected the proposition that, to "prevail," the defendants were required to secure a judgment against the plaintiffs. On the contrary, the appellate court concluded, "a defendant has 'fulfilled its primary objective whenever the plaintiff's challenge is rebuffed, irrespective of the precise reason for the court's decision,' and that therefore "[t]he defendant may prevail even if the court's final judgment rejects the plaintiff's claim for a nonmerits reason."²¹⁶⁸ The court therefore affirmed the district court's identification of the defendants as the prevailing parties.

A different opinion arising from litigation in the same district addressed the question of whether the voluntary dismissal of claims against a group of defendants, along with the service of a covenant not to sue rendered the defendants prevailing parties under Section 35(a).²¹⁶⁹ Although the lack of an actionable case and controversy created by the covenant led the court to dismiss the defendants' counterclaims with prejudice, the court held the defendants were prevailing parties based on their success in defending against the plaintiffs' claims. According to the court:

Both the dismissal with prejudice, and the Covenant—which Defendants have obtained through this litigation—materially alter the legal relationship of the parties. The dismissal of Defendants' counterclaims as moot does not change the calculus because, as a result of the litigation, Defendants will never face an infringement action or claim by Plaintiffs involving the Trademarks at issue.²¹⁷⁰

In contrast, a panel of the California Court of Appeal determined that neither the plaintiff nor the defendant in a right of publicity dispute was a prevailing party for purposes of a requested fee award under the law of that state.²¹⁷¹ In a jury trial, the plaintiff sought an award of over \$23.5 million, while the defendant encouraged the

²¹⁶⁷ See *Manhattan Review LLC v. Yun*, 919 F.3d 149 (2d Cir. 2019).

²¹⁶⁸ *Id.* at 153 (quoting *CRST Van Expedited, Inc. v. E.E.O.C.*, 136 S. Ct. 1642, 1651 (2016)).

²¹⁶⁹ See *Lifeguard Licensing Corp. v. Kozak*, 371 F. Supp. 3d 114 (S.D.N.Y. 2019).

²¹⁷⁰ *Id.* at 131.

²¹⁷¹ See *Olive v. Gen. Nutrition Ctrs., Inc.*, 242 Cal. Rptr. 3d 15 (Ct. App. 2018), *reh'g denied* (Jan. 23, 2019), *review denied* (Apr. 17, 2019).

jury to reach a figure of only \$4,800. Based on the jury's award of \$1.1 million, the trial court, relying in part on the facial expressions of the parties' counsel after learning of the verdict, concluded that, given the "practical realities" of the case, the trial had ended in a draw.²¹⁷² Holding that "it is possible for a trial court to conclude that neither party prevailed because neither party realized its litigation objectives," the appellate court affirmed.²¹⁷³ As it explained, "the trial court was free to view [the jury's verdict] as a mixed result and then exercise its discretion to determine whether one party prevailed, or whether neither party prevailed because neither achieved its practical litigation objectives."²¹⁷⁴

**(B) Eligibility of Prevailing Parties for
Awards of Attorneys' Fees**

(1) Fee Requests by Prevailing Plaintiffs

Outside the context of Section 35(b)'s virtually automatic award of fees to prevailing plaintiffs in counterfeiting cases,²¹⁷⁵ the Supreme Court's interpretations of the test for awards of attorneys' fees under Section 285 of the Patent Act²¹⁷⁶ in *Octane Fitness, LLC v. Icon Health & Fitness, Inc.*,²¹⁷⁷ continued to play a significant role in interpretations of Section 35(a), which, like Section 285, codifies an "exceptional case" standard. For example, the Fifth Circuit affirmed the grant of a fee petition of a plaintiff that had successfully challenged the adoption by a competitor of a stylized bird of prey identical to one used by the plaintiff.²¹⁷⁸ Referring to its past adoption of the *Octane Fitness* standard,²¹⁷⁹ the court remarked, "[a]s we have explained, a fee award may be warranted either where the prevailing party stood out in terms of the strength of its litigating position or where the non-prevailing party litigated the case in an "unreasonable manner."²¹⁸⁰ Addressing the first prong of the *Octane Fitness* test, it agreed with the district court that so many of the relevant likelihood-of-confusion factors favored

²¹⁷² *Id.* at 29.

²¹⁷³ *Id.* at 32.

²¹⁷⁴ *Id.*

²¹⁷⁵ For an example of an opinion awarding fees under Section 35(a) based largely on the defendants' litigation-related misconduct (including assertion of fifty-two affirmative defenses and discovery violations) and not on Section 35(b), despite jury verdict of counterfeiting, see *John Wiley & Sons, Inc. v. Book Dog Books, LLC*, 327 F. Supp. 3d 606, 644 (S.D.N.Y. 2018).

²¹⁷⁶ 35 U.S.C. § 285 (2018).

²¹⁷⁷ 134 S. Ct. 1749 (2014).

²¹⁷⁸ See *Alliance for Good Gov't v. Coal. for Better Gov't*, 919 F.3d 291 (5th Cir. 2019).

²¹⁷⁹ See *Baker v. DeShong*, 821 F.3d 620, 623 (5th Cir. 2016).

²¹⁸⁰ *Alliance for Good Gov't*, 919 F.3d at 295.

the plaintiff's position that confusion apparently had been the defendant's intent when adopting its mark; moreover, "[the defendant] presented meritless defenses at the summary judgment stage: a laches argument that was not supported by any credible evidence, as well as the bare assertion that the composite marks were different because one depicted an eagle while the other depicted a hawk."²¹⁸¹ Then, turning to the second prong, it affirmed the district court's conclusion that the defendant had litigated the matter in an unreasonable manner by pursuing unsupported defenses, a counterclaim, and a motion to dismiss, as well as refusing to cooperate in the scheduling of depositions.²¹⁸² That the defendant was "the unwilling participant in a lawsuit initiated by [the plaintiff]" did not excuse the defendant's conduct and that of its counsel.²¹⁸³

In opinions granting plaintiffs' motions for awards of fees under Section 35(a), some California federal district courts neglected to apply the *Octane Fitness* standard,²¹⁸⁴ despite the Ninth Circuit's prior endorsement of that test.²¹⁸⁵ According to one such court, "[a] case is considered exceptional 'when the infringement is malicious, fraudulent, deliberate, or willful,' however, no egregious conduct or bad faith is required."²¹⁸⁶ Whether that arguable lapse made a difference in the outcome is open to question, however, in light of the voluminous evidence in the summary judgment record of intentional misconduct by the defendants. That misconduct included cybersquatting, the filing of spurious changes of address for registrations owned by a subsidiary of the plaintiff, the fraudulent procurement of a registration of a mark owned by the plaintiff, and the dissemination of literally false advertising in which the defendants claimed credit for construction projects actually undertaken by the plaintiff and its subsidiary. As the court summarized the state of things, "[t]here is ample evidence that Defendants willfully and deliberately infringed upon [Plaintiff's

²¹⁸¹ *Id.* at 296.

²¹⁸² *Id.*

²¹⁸³ *Id.* at 297.

²¹⁸⁴ *See, e.g.,* Nat'l Grange of the Order of Patrons of Husbandry v. Cal. Guild, 334 F. Supp. 3d 1057, 1070 (E.D. Cal.) (holding, in cursory treatment of issue and without reference to *Octane Fitness*, that prevailing lead plaintiff was entitled to recover its fees based on "intentional nature" of infringement and false advertising), *reconsideration denied sub nom.* Nat'l Grange v. Cal. Guild, No. 2:16-cv-0201 WBS DB, 2018 WL 5270563 (E.D. Cal. Oct. 22, 2018), *appeal docketed*, No. 18-16671 (9th Cir. Sept. 5, 2018).

²¹⁸⁵ *See* SunEarth, Inc. v. Sun Earth Solar Power Co., 839 F.3d 1179, 1180-81 (9th Cir. 2016).

²¹⁸⁶ *AECOM Energy & Constr., Inc. v. Ripley*, 348 F. Supp. 3d 1038, 1065 (C.D. Cal. 2018) (quoting *Fifty-Six Hope Rd. Music v. A.V.E.L.A., Inc.*, 778 F.3d 1059, 1079 (9th Cir. 2015)), *reconsideration denied*, No. CV 17-5398-RSWL-SSx, 2019 WL 2610953 (C.D. Cal. Apr. 24, 2019), *appeal docketed*, No. 19-55588 (9th Cir. May 23, 2019).

marks] in an elaborate scheme to pass themselves off as the original [subsidiary of Plaintiff].”²¹⁸⁷

Of course, not all fee petitions by prevailing plaintiffs succeeded and, indeed, *Octane Fitness* led to the denial of at least some.²¹⁸⁸ Thus, for example, the Eighth Circuit invoked *Octane Fitness* to affirm a refusal to award fees to a plaintiff that, although prevailing below in a jury trial, suffered reverses on appeal.²¹⁸⁹ As it held without extended explanation, “the district court did not abuse its discretion in finding [the] case was not ‘exceptional’ with respect to either the “substantive strength of [the plaintiffs] litigating position” or “the unreasonable manner in which the case was litigated.”²¹⁹⁰

A more detailed application of *Octane Fitness* in a dispute similarly originating in the Eighth Circuit also led to the denial of an award of fees.²¹⁹¹ The case presented an unusual factual scenario: Having abandoned their use of the marks in question based on the plaintiffs’ adoption of them, the defendants sought to reclaim the marks by promoting them through online media and registering one with the USPTO. Although finding the defendants liable for infringement, the court credited their belief that they owned the marks as a basis for denying the plaintiffs’ fee petition:

On one hand, the Court cannot condone [the defendants’] vigilante attempt to wrest control of the marks from [the plaintiffs]. On the other, the Court cannot conclude that [an individual defendant] deliberately acted unlawfully given the Court’s factual finding that [the lead defendant] used the terms first. [The individual defendant] testified that it was his understanding that he was entitled to resume use of the marks. Even if that conclusion was not the result of sound legal advice, the Court finds it a plausible explanation of the infringement. Moreover, the totality of the circumstances surrounding this case shows that [the lead plaintiff] is not an innocent actor. Because this inquiry is equitable by nature,

²¹⁸⁷ *Id.*

²¹⁸⁸ *See, e.g.,* *Evoqua Water Techs. LLC v. M.W. Watermark, LLC*, 128 U.S.P.Q.2d 1775, 1784 (W.D. Mich. 2018) (“The jury’s reasonable findings of no liability for [an individual defendant]; the absence of willful infringement; and \$0 in damages vindicate the core defense case through trial. Moreover, as the Court has indicated, a reasonable jury weighing all the relevant factors for infringement could have decided all the issues in Defendants’ favor. Thus, an award of attorney’s fees under § 1117(a) is not warranted.”).

²¹⁸⁹ *See Sturgis Motorcycle Rally, Inc. v. Rushmore Photo & Gifts, Inc.*, 908 F.3d 313 (8th Cir. 2018), *on remand*, 129 U.S.P.Q.2d 1392 (D.S.D. 2019).

²¹⁹⁰ *Id.* at 346 (quoting *Octane Fitness*, 572 U.S. at 544).

²¹⁹¹ *See Safeway Transit LLC v. Disc. Party Bus, Inc.*, 334 F. Supp. 3d 995 (D. Minn. 2018), *appeal docketed*, No. 18-2990 (8th Cir. Sept. 17, 2018).

[the lead plaintiff's] own bad acts may not pass without comment.²¹⁹²

“For all these reasons,” the court declined “to find this case exceptional and will deny [the plaintiffs’] request for an award of attorneys’ fees.”²¹⁹³

So too did a different court decline to award fees to a prevailing plaintiff based on the defendants’ ill-fated decision to dispute the likelihood of confusion between the parties’ marks—REAL CALLER vs. REEL CALLER, both for smartphone caller-identification applications—as well as their assertion of a meritless claim of prior rights and several (unidentified) unsuccessful affirmative defenses.²¹⁹⁴ Without reference to the adoption by its reviewing court of *Octane Fitness*, the court held as an initial matter that “[t]he Ninth Circuit has explained that “generally a trademark case is exceptional for purposes of an award of attorneys’ fees when the infringement is malicious, fraudulent, deliberate or willful.”²¹⁹⁵ It then denied the plaintiff’s fee petition with the following explanation:

Plaintiff’s arguments regarding frivolous defenses with regard to consumer confusion are well taken. But the Defendants’ alleged conduct, under the totality of the circumstances, does not elevate this case to the exceptional standard that triggers attorneys’ fees under the Lanham Act. Defendants had every right to assert counterclaims and the bald assertion that Defendants continued to pursue these claims solely because the pursuit was economically rational falls flat. The absence of any motions to compel supports Defendants’ contention that they did not act in bad faith during discovery. This case does not present the appropriate circumstances to award attorneys’ fees or costs.²¹⁹⁶

(2) Fee Requests by Prevailing Defendants

Having not previously had the opportunity to address the significance of *Octane Fitness*, the Second Circuit received one in a false advertising action in which the prevailing defendants had secured a multimillion dollar award from the district court.²¹⁹⁷ Consistent with the holdings of every other federal appellate court to address the issue, the court held the *Octane Fitness* standard

²¹⁹² *Id.* at 1008.

²¹⁹³ *Id.* at 1008-09.

²¹⁹⁴ *See* Talent Mobile Dev., Inc. v. Headios Grp., 382 F. Supp. 3d 953 (C.D. Cal. 2019), *appeal docketed*, No. 19-55258 (9th Cir. Mar. 5, 2019).

²¹⁹⁵ *Id.* at 964 (quoting *Lindy Pen Co. v. Bic Pen Corp.*, 982 F.2d 1400, 1409 (9th Cir. 1993)).

²¹⁹⁶ *Id.*

²¹⁹⁷ *See* Sleepy’s LLC v. Select Comfort Wholesale Corp., 909 F.3d 519 (2d Cir. 2018).

applicable to fee petitions brought pursuant to Section 35(a): “[U]nder the Lanham Act, an exceptional case is one that stands out from others in the manner articulated by *Octane Fitness*.”²¹⁹⁸ In vacating and remanding the matter, the court declined to resolve on appeal the issue of the defendants’ eligibility under *Octane Fitness* for reimbursement of their fees, leaving that for the district court to address in the first instance. In doing so, however, the court volunteered that the survival of the plaintiff’s false advertising cause of action at the summary judgment stage of the case properly should weigh against a finding that the case was an exceptional one.²¹⁹⁹

The First Circuit also jumped aboard the *Octane Fitness* bandwagon, but it did so in an opinion leading to an actual resolution of the prevailing defendant’s fee petition.²²⁰⁰ The defendant alleged that the district court mistakenly required the defendant to demonstrate the existence of an exceptional case under Section 35(a) by clear and convincing evidence. The First Circuit, however, concluded that the district court had not imposed such an elevated standard of proof on the defendant, and its review of the record disclosed that the district court had not abused its discretion in declining to award fees. On the contrary, it concluded, the district court had anticipated its own holding on the applicability of *Octane Fitness* by applying the test established by the Supreme Court’s opinion. Moreover, although the defendant accused the plaintiff of abuse of process and having brought his suit in bad faith, the court concluded that “[t]he district court was intimately familiar with the totality of the circumstances in this case, and reasonably found the case not to be an ‘exceptional’ one warranting the sought-after award.”²²⁰¹

An Eighth Circuit opinion affirming a refusal to award fees below similarly demonstrated the difficulties prevailing defendants often face when pursuing reimbursement of their fees.²²⁰² That disposition arose from a twelve-year dispute in which the plaintiff had wrangled favorable outcomes from the Supreme Court, the Eighth Circuit, and a jury. In the final analysis, though, the plaintiff’s case fell short when another jury stripped its mark of incontestable status after finding the plaintiff had submitted a fraudulent Section 15 declaration; the declaration’s invalidation led the district court to give issue-preclusive effect to yet another jury’s finding that the plaintiff’s mark was descriptive and lacked acquired

²¹⁹⁸ *Id.* at 531.

²¹⁹⁹ *Id.* at 531 n.7.

²²⁰⁰ *See* Scholz v. Goudreau, 901 F.3d 37 (1st Cir. 2018).

²²⁰¹ *Id.* at 50.

²²⁰² *See* B&B Hardware, Inc. v. Hargis Indus., 912 F.3d 445 (8th Cir. 2018) (“*B&B Hardware II*”), *cert. denied*, 140 S. Ct. 218 (2019).

distinctiveness. The district court denied the defendant's request for reimbursement of its fees, and the Eighth Circuit affirmed. The appellate court held:

This case does not present an example of groundless, unreasonable, or vexatious litigation, as it has arguable merit on both sides—evidenced by the fact that both parties have prevailed at various times throughout its 12-year history. We cannot say that [the plaintiff] pursued litigation in bad faith, as it received a favorable Supreme Court ruling and reasonably believed it could prevail. Therefore, the district court did not abuse its discretion in finding this an unexceptional case, and we affirm its denial of [the defendant's] motion for attorney fees and nontaxable litigation costs.²²⁰³

At the trial level, a Virginia federal district court concluded in an application of *Octane Fitness* that the success of a counterclaim defendant in invalidating its opponent's claimed marks as generic did not entitle the counterclaim defendant to an award of fees.²²⁰⁴ The counterclaim plaintiff's ownership of federal registrations helped its cause because “[e]quipped with [the] presumption of validity [attaching to the registrations], it was not objectively unreasonable for [the counterclaim plaintiff] to take the position that the [m]arks were valid. To find otherwise would undermine the policy of encouraging trademark owners to defend and enforce their presumptively valid trademarks.”²²⁰⁵ Moreover, the court rejected the counterclaim defendant's argument that the counterclaim plaintiff had behaved unreasonably by arguing (unsuccessfully) that the invalidation of a registered mark required proof of genericness by clear and convincing evidence, that the counterclaim defendant's case rested in part on unauthenticated hearsay, that the court should have reconsidered a summary judgment order, and that the counterclaim defendant had engaged in actionable false advertising. “In summary,” the court held:

[The counterclaim defendant] has pointed to no sound basis for concluding, by a preponderance of the evidence, that this case is “exceptional, that it “stands out” from any other ordinary trademark case. To adopt a fitting analogy, if the proverbial bell curve representing the range of trademark cases was developed, this case would clearly fall in the middle, or at least within two standard deviations of the mean. Therefore, because this case is not “exceptional,” [the

²²⁰³ *Id.* at 454.

²²⁰⁴ See *Express Homebuyers USA, LLC v. WBH Mktg. Inc.*, 343 F. Supp. 3d 562 (E.D. Va.), reconsideration denied, No. 1:17-CV-736, 2018 WL 6616675 (E.D. Va. Aug. 29, 2018), appeal docketed, No. 18-2149 (4th Cir. Oct. 22, 2019).

²²⁰⁵ *Id.* at 567.

counterclaim defendant's] motion for attorney's fees must be denied.²²⁰⁶

A New York federal district court similarly applied *Octane Fitness* to deny an award of fees to two defendants who prevailed in the action against them when the plaintiffs proffered a covenant not to sue so ironclad that the court held no actionable case and controversy remained between the parties.²²⁰⁷ Addressing the strength of the plaintiffs' claims before that development, the court noted that the plaintiffs owned incontestable registrations of the marks they sought to protect and that, in addition to having defeated the defendants' motion for summary judgment, the plaintiff had successfully challenged certain of the defendants' affirmative defenses through their own motion.²²⁰⁸ The court then rejected the defendants' argument that the plaintiffs' litigation-related conduct was sufficiently unreasonable to render the case an exceptional one, finding in the process that the following actions by the plaintiffs did not mandate the contrary result: (1) the naming of individual defendants; (2) the pursuit of statutory damages exceeding two million dollars; (3) resistance to discovery requests, which forced the defendants to pursue motions to compel and for sanctions; (4) the proffer of the covenant not to sue on the eve of trial; and (5) the (apparently inaccurate) representation that the covenant not to sue tracked the one held dispositive in *Already, Inc. v. Nike, Inc.*²²⁰⁹ "In short," the court concluded, "this case is not exceptional and does not warrant exercise of the Court's discretion to award attorneys' fees."²²¹⁰

By the same token, the successful defense of a claim of false advertising claim did not lead to an award of fees under *Octane Fitness* by a Michigan federal district court.²²¹¹ With respect to the weakness of the plaintiff's case, the court noted it had denied the defendants' motion for summary judgment earlier in the case, as well as that, "[a]t trial, the parties essentially left the jury to decide which of their respective, self-interested witnesses were more credible."²²¹² unable to prevail under that prong of the *Octane Fitness* standard, the defendants advanced several bases for their assertion that the plaintiff's litigation-related conducted rendered the case was an "exceptional" one under Section 35(a). For example, they accused the plaintiff of serving overbroad discovery requests,

²²⁰⁶ *Id.* at 569 (quoting *Octane Fitness*, 134 S. Ct. at 1756).

²²⁰⁷ *See Lifeguard Licensing Corp. v. Kozak*, 371 F. Supp. 3d 114 (S.D.N.Y. 2019).

²²⁰⁸ *Id.* at 131.

²²⁰⁹ 568 U.S. 85 (2013).

²²¹⁰ *Lifeguard Licensing Corp.*, 371 F. Supp. 3d at 134.

²²¹¹ *See, e.g., Evoqua Water Techs. LLC v. M.W. Watermark, LLC*, 128 U.S.P.Q.2d 1775 (W.D. Mich. 2018).

²²¹² *Id.* at 1785.

but the court pointed out that that strategy had not increased the defendants' fees because "[the defendants] simply objected to these requests and did not comply."²²¹³ Likewise, although "[t]here was definitely some evidence at trial suggesting that [the plaintiff] thought that litigation was warranted simply because [the plaintiff] could absorb the costs more easily than [the defendants]," the court found that consideration did not detract from the plaintiff's good-faith pursuit of its claim.²²¹⁴ Finally, the court found, "[the plaintiff] did prevail on one of its claims [for trademark infringement]—albeit without winning money damages. And the jury could reasonably have decided the other claims differently than in its verdict."²²¹⁵

(C) Calculation of Attorneys' Fees

As always, the "lodestar" method of calculating fees played a role in some reported opinions. That method entails as a threshold calculation the multiplication of a reasonable hourly rate by a reasonable number of hours invested by counsel for the prevailing party.

The first step under the lodestar analysis is a determination of appropriate hourly rates for the prevailing party's counsel. Some proffered rates met with judicial approval, including a set in an appeal to the Seventh Circuit from a contempt proceeding before a Wisconsin federal district court.²²¹⁶ In holding that the district court had not abused its discretion by accepting the rates charged by the plaintiff's counsel, the appellate court noted that "[t]o support this finding, the [district] court relied in part on a third-party declaration from a Wisconsin attorney familiar with trademark infringement litigation who observed that the hourly rates charged by [the plaintiff's] counsel were aligned with market rates."²²¹⁷

In contrast, some courts did not sign off on the hours claimed to have been worked by the prevailing party's counsel.²²¹⁸ For example, in an appeal from a contempt finding below, the Seventh Circuit affirmed a fee award in its entirety, noting with approval the district court's skeptical review of the time records of the plaintiff's counsel. That review led the district court to "trim[] seven hours of billed

²²¹³ *Id.* at 1786.

²²¹⁴ *Id.*

²²¹⁵ *Id.*

²²¹⁶ *See* Seventh Ave., Inc. v. Shaf Int'l, Inc., 909 F.3d 878 (7th Cir. 2018).

²²¹⁷ *Id.* at 881.

²²¹⁸ *See, e.g.,* John Wiley & Sons, Inc. v. Book Dog Books, LLC, 327 F. Supp. 3d 606, 645-47 (S.D.N.Y. 2018) (reducing claimed fees in trademark and copyright action based on "hundreds" of redacted time entries, "block-billing [that] impeded this Court's ability to survey 141 pages containing nearly 7,000 time entries," and "more time . . . devoted to some legal tasks than appears reasonable to this Court" but nevertheless awarding \$4,137,081.70 in fees).

time from [the plaintiff's] outside counsel [after] finding the time redundant of work performed by others and not necessary to the prosecution of the alleged trademark infringement."²²¹⁹ Likewise, the district court also cut time billed by the plaintiff's in-house counsel because "while . . . the overall work [was] necessary and appropriate, . . . certain activities could have been accomplished by a paralegal . . ."²²²⁰ The Seventh Circuit found "nothing unreasonable about these adjustments."²²²¹

A final issue courts entertaining fee petitions must address is that of apportionment or, in other words, the attribution of fees incurred in the prosecution or defense of actions between those that are recoverable under the Lanham Act from those that are not. The most substantive opinion to tackle the question came from the Second Circuit in an appeal from a district court finding that 75 percent of fees incurred by a set of prevailing defendants were attributable to its defense of a claim for false advertising under Section 43(a) that was abandoned in between two trials of the matter in favor of the plaintiff's pursuit of several state law causes of action.²²²² Finding "the district court's high apportionment based solely on the empty, but eventually abandoned, Lanham Act claim puzzling at best,"²²²³ the appellate court vacated it. It acknowledged that other circuits had held prevailing parties eligible to recover their total fees under Section 35(a) if their opponents' claims were so intertwined that it was impossible to distinguish between them.²²²⁴ Nevertheless, it concluded that "permitting full recovery for both Lanham Act and non-Lanham Act claims because of the difficulty of differentiating between them could permit, as might be the case here, a very small Lanham Act tail to improperly wag a huge attorney's-fee dog."²²²⁵ It therefore remanded the apportionment question to the district court with the strong suggestion that the 75 percent apportionment was inappropriate because:

Here, the plaintiff brought what appears to be just such an all-but-the-kitchen-sink complaint, comprising ten causes of action and six theories of liability, only the last of which purportedly arose under the Lanham Act. Indeed, in the introductory portion of the Amended Complaint, which generally summarized the plaintiff's claims to follow, the

²²¹⁹ *Id.* at 881.

²²²⁰ *Id.*

²²²¹ *Id.*

²²²² *See Sleepy's LLC v. Select Comfort Wholesale Corp.*, 909 F.3d 519 (2d Cir. 2018).

²²²³ *Id.* at 531.

²²²⁴ *Id.* at 532 (citing *Procter & Gamble Co. v. Amway Corp.*, 280 F.3d 519, 527 (5th Cir. 2002); *Gracie v. Gracie*, 217 F.3d 1060, 1069 (9th Cir. 2000)).

²²²⁵ *Id.*

plaintiff did not so much as mention the Lanham Act. Moreover, . . . when the plaintiff first appealed this case to this Court, it in effect abandoned its Lanham Act claim by not appealing the district court’s dismissal of it. These factors suggest that the Lanham Act claim was not the central thrust of the plaintiff’s lawsuit—nor a massive burden on the defendants’ defense—and therefore may not have accounted for most—or even much—of the attorneys’ work.²²²⁶

“Of course,” the appellate court further explained, “the district court may still have reasons for concluding otherwise, but it must tell us what they are before we attempt to further evaluate its decision.”²²²⁷

The Fifth Circuit addressed the same issue and reached much the same conclusion.²²²⁸ The plaintiff in the appeal before that court successfully had demonstrated the defendant’s infringement of a logo owned by the plaintiff; the defendant, however, had prevailed on the plaintiff’s claim for infringement of a word mark. The district court granted the entirety of the plaintiff’s fee petition only to have the appellate court vacate that disposition in light of the defendant’s partial victory and, additionally, the plaintiff’s having dropped its causes of action other than that for infringement. The latter court held that “[w]hile [the plaintiff’s] [logo]-mark claim may be intertwined with its other claims to some extent, ‘the impossibility of making an *exact* apportionment does not relieve the district court of its duty to make *some* attempt to adjust the fee award in an effort to reflect an apportionment.’”²²²⁹ It therefore remanded the action for the district court “to account for billed time for claims on which [the plaintiff] did not prevail.”²²³⁰

B. The Relationship Between Courts and the United States Patent and Trademark Office

1. Judicial Review of, and Deference to, United States Patent and Trademark Office Determinations

Litigants most commonly invite courts to defer to actions by the USPTO in three scenarios. The first occurs if the Trademark Trial and Appeal Board previously has produced findings and holdings bearing on one or more marks at issue. A court also may have an opportunity to defer to the USPTO if the parties are engaged in

²²²⁶ *Id.* at 533 (footnote omitted) (citations omitted).

²²²⁷ *Id.*

²²²⁸ *See Alliance for Good Gov’t v. Coal. for Better Gov’t*, 919 F.3d 291 (5th Cir. 2019).

²²²⁹ *Id.* at 298 (quoting *Gracie v. Gracie*, 217 F.3d 1060, 1070 (9th Cir. 2000)).

²²³⁰ *Id.*

ongoing litigation before the Board, and one moves the court to stay its proceedings in favor of allowing the Board to take the first bite at the apple. Finally, litigants often encourage courts to defer to actions taken by examining attorneys in processing applications filed by one of the parties, or, less commonly, by a third party.

Two cases appealed to the United States District Court for the Northern District of Virginia by unsuccessful litigants before the Board fell within the scope of the first of these scenarios. In the cancellation action leading to the first appeal, the Board found the plaintiff had misrepresented the source of its goods in violation of Section 14(3)²²³¹ by: (1) knowingly adopting a mark identical to one used by the defendants in Mexico; (2) copying the defendant's Mexican packaging; and (3) repeatedly invoking the reputation of the defendants' product.²²³² In affirming the Board's invalidation of the plaintiff's registration, the court held with respect to the applicable standard of review that "any new evidence submitted to the court on a disputed factual question is considered *de novo*, while factual findings made by the Board which are untouched by new evidence presented to the court are reviewed under the substantial evidence standard mandated by the Administrative Procedure Act."²²³³ Noting the plaintiff's failure to adduce any new evidence requiring a *de novo* review, the court found the Board's decision "was not arbitrary, capricious, or otherwise not in accordance with law."²²³⁴

The second district court appeal arose from a Board finding that the plaintiff's descriptive mark had not acquired distinctiveness prior to the defendant's priority date.²²³⁵ Because the plaintiff failed to adduce any new evidence or testimony on the issue, the court concluded the plaintiff was not entitled to a *de novo* review of the Board's dismissal of the plaintiff's notice of opposition.²²³⁶ Rather, "[i]f no new evidence was provided, this Court should uphold the TTAB unless its decision was arbitrary, capricious, or not in accordance with law."²²³⁷ Addressing that issue, the court concluded on the defendant's motion for summary judgment that "[t]he TTAB reached its decision after a full trial and after reviewing a voluminous record. The opinion is thorough and supported by the

²²³¹ 15 U.S.C. § 1064(3) (2018).

²²³² See *Belmora, LLC v. Bayer Consumer Care AG*, 338 F. Supp. 3d 477, 488 (E.D. Va. 2018) (citation omitted), *appeal docketed*, No. 18-2183 (4th Cir. Oct. 9, 2018).

²²³³ *Id.* at 484 (citation omitted).

²²³⁴ *Id.* at 488.

²²³⁵ See *RXD Media, LLC v. IP Application Dev.*, 377 F. Supp. 3d 588 (E.D. Va. 2019), *appeal docketed*, No. 19-1461 (4th Cir. 2019).

²²³⁶ *Id.* at 593.

²²³⁷ *Id.*

law. The TTAB did not take arbitrary or capricious action here and its decision should be affirmed.”²²³⁸

Although considerably rarer than the other two, the second scenario presented itself in an action before a Delaware federal district court.²²³⁹ Unusually, the court decided to stay its own proceedings to allow the Board to resolve a prior-filed action between the same parties. It did not do so by relying on the primary jurisdiction doctrine, under which courts should defer to administrative agencies “in cases raising issues of fact not within the conventional experience of judges or cases requiring the exercise of administrative discretion”;²²⁴⁰ after all, the court concluded, it was itself “well equipped to decide the issues of likelihood-of-confusion and dilution.”²²⁴¹ Instead, it identified three other reasons for its decision: (1) “the decision on likelihood-of-confusion may . . . have a preclusive effect after the parties have engaged in the review and appeals process following a TTAB decision”;²²⁴² (2) “[e]ven absent a preclusive effect, courts look to the TTAB for its analysis on both the issues of likelihood-of-confusion and dilution as highly instructive and persuasive”;²²⁴³ and (3) the proceeding before the Board had been pending for three years before the filing of the district court action, and the parties had engaged in “extensive” discovery.²²⁴⁴ Under these circumstances, “the interests of judicial efficiency support a stay of the instant litigation pending the outcome of the TTAB proceeding,”²²⁴⁵ especially in light of the absence of any prejudice to the plaintiff.²²⁴⁶

Finally, the Eleventh Circuit entertained an appeal arising from facts falling within the third scenario.²²⁴⁷ Having been found liable for infringement, the defendant invoked the USPTO’s registration of its mark despite prior registrations of the plaintiff’s mark. It then argued that the Supreme Court’s opinion in *B&B Hardware, Inc. v. Hargis Indus.*²²⁴⁸ required deference to the Office’s apparent determination that confusion was unlikely between the parties’ marks. The court made short work of that contention, holding *B&B Hardware* inapposite:

²²³⁸ *Id.*

²²³⁹ See *Tigercat Int’l, Inc. v. Caterpillar Inc.*, 127 U.S.P.Q.2d 1132 (D. Del. 2018).

²²⁴⁰ *Far E. Conference v. United States*, 342 U.S. 570, 574 (1952).

²²⁴¹ *Tigercat Int’l*, 127 U.S.P.Q.2d at 1137.

²²⁴² *Id.*

²²⁴³ *Id.* at 1138.

²²⁴⁴ *Id.*

²²⁴⁵ *Id.*

²²⁴⁶ *Id.* at 1138-39.

²²⁴⁷ See *PlayNation Play Sys., Inc. v. Vex Corp.*, 924 F.3d 1159 (11th Cir. 2019).

²²⁴⁸ 575 U.S. 138 (2015).

B&B Hardware does not suggest that, absent a prior administrative finding, a district court deciding a trademark infringement action is bound—or even ought to be persuaded—by the PTO’s registration of the defendant’s mark. To the contrary, the Lanham Act expressly gives district courts the power to cancel federal trademarks issued by the PTO when they violate the Lanham Act. Absent issue preclusion, it was not clearly erroneous for the district court not to consider the PTO’s decision to approve [the defendant’s] trademark as a factor.²²⁴⁹

2. Judicial Authority Over Federal Registrations and Applications

Section 37 of the Act provides “[i]n any action involving a registered mark the court may determine the right to registration, order the cancellation of registrations, in whole or in part, restore cancelled registrations, and otherwise rectify the register with respect to the registrations of any party to the action.”²²⁵⁰ With considerable frequency, claims of fraudulent procurement and maintenance of registrations took center stage in litigation invoking Section 37. With near-equal frequency, however, those claims generally fell short.²²⁵¹

One such unsuccessful claim met with misfortune at the hands of the Ninth Circuit, which affirmed a district court’s decision to overturn a jury finding that the lead plaintiff in a dispute between competitors in the tire industry had secured a registration covering a tire design only through fraudulent representations of acquired distinctiveness and nonfunctionality.²²⁵² It did so through an application of the following test:

To succeed on a claim for cancellation based on fraud, a claimant must establish the following elements: 1) a false representation regarding a material fact; 2) the registrant’s knowledge or belief that the representation is false; 3) the registrant’s intent to induce reliance upon the misrepresentation; 4) actual, reasonable reliance on the misrepresentation; and 5) damages proximately caused by that reliance.²²⁵³

²²⁴⁹ *PlayNation Play Sys.*, 924 F.3d at 1169 (citations omitted).

²²⁵⁰ 15 U.S.C. § 1119 (2018).

²²⁵¹ See, e.g., *Marshak v. Sheppard*, 381 F. Supp. 3d 261, 265-66 (S.D.N.Y. 2019) (rejecting defendants’ belated attempt to reargue fraudulent procurement claim under auspices of motion to set aside prior judgment for fraud on the court), *appeal docketed*, No. 19-1885 (2d Cir. June 24, 2019).

²²⁵² See *OTR Wheel Eng’g, Inc. v. W. Worldwide Servs., Inc.*, 897 F.3d 1008 (9th Cir. 2018).

²²⁵³ *Id.* at 1019.

The defendants' claim of fraud with respect to distinctiveness centered on a boilerplate representation to the USPTO by an employee of the lead plaintiff that the tire's appearance "is so distinctive that . . . tire manufacturers, distributors and customers can immediately identify the . . . tire solely by seeing its tread design."²²⁵⁴ According to the defendants, that representation was fraudulent "because it was made without gathering any data from manufacturers, distributors or customers."²²⁵⁵ The court found that theory wanting for several reasons, the first of which was that "[the declarant] did not purport to convey the results of any survey of customers, manufacturers, or distributors";²²⁵⁶ "[t]hus, the statement, by itself, did not constitute clear and convincing evidence a false representation regarding a material fact."²²⁵⁷ Another was the defendants' failure to adduce any evidence or testimony that, even if the statement was false, the declarant was aware of that falsity.²²⁵⁸ Finally, because the USPTO examiner assigned to the application had not accepted the declarant's averment of distinctiveness but had instead continued her refusal to register the design until the lead plaintiff mounted a full-blown showing of acquired distinctiveness, "there was not clear and convincing evidence that the examiner relied on [the] declaration in reaching her conclusion on acquired distinctiveness."²²⁵⁹

The court then turned its attention to the defendants' claim that, because the tread design at issue was self-cleaning, the lead plaintiff's alleged failure to disclose that functionality merited the registration's invalidation. That attack on the registration also fell short in light of evidence that the lead plaintiff's declarant had affirmatively advised the examiner of the tread's self-cleaning properties before successfully arguing that a distinctive angle of the tread was unrelated to those properties. "Given that [the lead plaintiff] had already acknowledged that the tread design made the tires self-cleaning," the court observed, "there was no omission of as material fact."²²⁶⁰

A South Carolina federal district court also rejected as a matter of law a claim of fraudulent procurement in a case between competitors in the market for fall-protection equipment.²²⁶¹ The registered mark in question was a shade of the color orange, for

²²⁵⁴ *Id.* at 1020.

²²⁵⁵ *Id.*

²²⁵⁶ *Id.*

²²⁵⁷ *Id.* at 1021.

²²⁵⁸ *Id.*

²²⁵⁹ *Id.*

²²⁶⁰ *Id.*

²²⁶¹ See *SafeRack, LLC v. Bullard Co.*, 350 F. Supp. 3d 438 (D.S.C. 2018), *report and recommendation adopted*, No. 2:17-cv-1613-RMG, 2019 WL 460699 (D.S.C. Feb. 5, 2019).

which the USPTO required a showing of acquired distinctiveness before issuing the plaintiff a registration on the Principal Register. Part of that showing consisted of the revenue collected by the plaintiff from sales of goods featuring the color, and discovery disclosed that some components of some of the goods were not orange. Based on that disclosure, the defendant argued the plaintiff had defrauded the Office, but the court found otherwise as a matter of law on the parties' cross-motions for summary judgment. As it concluded, "[s]imply because some part of a product does not have orange does not prevent [the plaintiff] from counting the sale as related to its orange color mark."²²⁶²

So too did an Illinois federal district court side with a plaintiff accused of failing to disclose the allegedly generic status of the dominant component—UGG—of a formerly registered composite mark for footwear.²²⁶³ The attorney who prosecuted the application that matured into the registration on behalf of the plaintiff's predecessor recalled responding to an examining attorney's inquiry about the component's potential meaning "that he didn't think [it had one] in the U.S., but that he thought ugg was used to identify sheepskin boots in Australia."²²⁶⁴ As the court summarized their position, the defendants contended that, had the prosecuting attorney truthfully disclosed that ugg was a generic term in Australia, "the examining attorney would have placed a disclaimer on the word UGG in the mark, which would have signaled the mark's generic status in future applications and prevented UGG from obtaining a trademark in the word itself."²²⁶⁵ But, having previously concluded that the mark was not generic in the United States, the court rejected that theory on the ground that "[e]ven assuming that with full disclosure, the examining attorney would have attached a disclaimer [of] UGG [to the application], it does not follow that the word ugg *is* generic. And because it is not generic to the relevant consumers in the U.S., [the plaintiff] may rightfully own its subsequent trademarks."²²⁶⁶ Equally to the point, because the registration in question had lapsed well before the outbreak of hostilities between the parties, "[a]ny fraudulent procurement of the [registration] had no impact on [the defendants], and so [they] cannot recover for that fraud or use it as a defense."²²⁶⁷ The plaintiff's motion for summary judgment on the issue therefore proved meritorious.

²²⁶² *Id.* at 455.

²²⁶³ *See Deckers Outdoor Corp. v. Australian Leather Pty. Ltd.*, 340 F. Supp. 3d 706 (N.D. Ill. 2018).

²²⁶⁴ *Id.* at 717.

²²⁶⁵ *Id.* at 718.

²²⁶⁶ *Id.*

²²⁶⁷ *Id.*

Finally, claims of fraudulent procurement grounded in allegedly false dates of first use failed badly. A California federal district court reached the usual result while addressing a claim that the plaintiff's predecessor had recited inaccurate dates of first use in two successful applications filed with the USPTO and one filed with the state of California.²²⁶⁸ Unless a claim of acquired distinctiveness by an applicant rests on a sworn averment of substantially continuous and exclusive use for a particular period of time,²²⁶⁹ an inaccurate date of first use is ordinarily immaterial to the issuance of a registration, provided that the actual date precludes the date of the claim. The court's holding to that effect while granting the plaintiff's motion to dismiss the defendants' counterclaim for cancellation therefore was no surprise where the plaintiff's two federal registrations are concerned; the same was true of the court's application of that holding to the plaintiff's California registration.²²⁷⁰

In granting a counterclaim plaintiff's preliminary injunction, a Maryland federal district court also rejected a date-of-first-use-based claim of fraudulent procurement.²²⁷¹ The registration in question was owned by the counterclaim plaintiff, and it recited a date of first use of June 1, 1984, for "conducting public opinion polls" and "political consultancy," both of which fell within the same International Class. The counterclaim defendant conceded the accuracy of the June 1, 1984, date with respect to the counterclaim plaintiff's polling services, but it argued the date was inaccurate where political consultancy was concerned. Rejecting that argument, the court noted that Trademark Rule 2.34(a)(v)²²⁷² required a recitation of only a single date of first use for goods or services falling into the same class. Thus, "[e]ven if [the counterclaim defendant] is correct, there is still no fraud. . . . [The counterclaim plaintiff] accurately stated the date of first use as required by federal regulations."²²⁷³

These outcomes outstanding, some claims of fraud gained traction. Perhaps the most notable exception to general judicial hostility towards fraudulent procurement and maintenance claims came from the Second Circuit, which backslid from the strict test for

²²⁶⁸ See *Teeter-Totter, LLC v. Palm Bay Int'l, Inc.*, 344 F. Supp. 3d 1100 (N.D. Cal. 2018).

²²⁶⁹ For an unreported opinion over the past year ordering the cancellation of a fraudulently procured registration based on a false claim under Section 2(f) of five years' continuous use, see *Anello Fence, LLC v. VCA Sons, Inc.*, No. CV133074JMVJBC, 2019 WL 351899, at *13 (D.N.J. Jan. 28, 2019).

²²⁷⁰ *Teeter-Totter*, 344 F. Supp. 3d at 1110.

²²⁷¹ See *Mayson-Dixon Strategic Consulting, LLC v. Mason-Dixon Polling & Strategic Consulting, Inc.*, 324 F. Supp. 3d 569 (D. Md. 2018).

²²⁷² 37 C.F.R. 2.34(a)(v) (2018).

²²⁷³ *Mayson-Dixon Strategic Consulting*, 324 F. Supp. 3d at 576.

fraud applied in such opinions as *In re Bose Corp.*²²⁷⁴ in favor of one resembling that for negligence.²²⁷⁵ As the Second Circuit saw the matter:

Our precedents require a party alleging fraudulent registration to prove by clear and convincing evidence:

1. A false representation regarding a material fact.
2. The person making the representation knew *or should have known* that the representation was false (“scienter”).
3. An intention to induce the listener to act or refrain from acting in reliance on the misrepresentation.
4. Reasonable reliance on the misrepresentation.
5. Damage proximately resulting from such reliance.²²⁷⁶

The underlying basis of the counterclaim plaintiff’s first claim of fraud was that the counterclaim defendant had agreed in a prior settlement between the parties not to use its mark in connection with particular articles of clothing and to amend its applications and registrations in the USPTO to delete those goods. As the court summarized the counterclaim plaintiff’s first theory of fraud, “[the counterclaim plaintiff] argues that [the counterclaim defendant] ‘deliberately withheld’ the Agreement from the PTO while it continued to own and apply for new and renewal registrations,”²²⁷⁷ which constituted a material omission “because ‘the PTO refuses to register marks for goods that the applicant is contractually prohibited from registering.’”²²⁷⁸ The district court had granted summary judgment in the counterclaim defendant’s favor, but the appellate court vacated that disposition, holding instead that “[the counterclaim defendant] has failed to show an absence of clear and convincing evidence supporting [the counterclaim plaintiff’s] cancellation counterclaim, and that [the counterclaim plaintiff] has raised triable issues of fact as to whether [the counterclaim defendant] knowingly made material omissions and false statements with intent to deceive the PTO.”²²⁷⁹ Specifically:

²²⁷⁴ 580 F.3d 1240 (Fed. Cir. 2009).

²²⁷⁵ See *Excelled Sheepskin & Leather Coat Corp. v. Or. Brewing Co.*, 897 F.3d 413 (2d Cir. 2018).

²²⁷⁶ *Id.* at 421-22 (emphasis added).

The court’s adoption of a known-or-should-have-known standard came after it had disavowed that standard in its last reported opinion to address the issue. See *MPC Franchise, LLC v. Tarantino*, 826 F.3d 653, 659 (2d Cir. 2016) (“[A]ny suggestion in [yet another earlier opinion] that the scienter element is satisfied when a plaintiff shows merely that an applicant ‘should have known’ the falsity of a representation is dicta.”).

²²⁷⁷ *Excelled Sheepskin & Leather Coat Corp.*, 897 F.3d at 422.

²²⁷⁸ *Id.*

²²⁷⁹ *Id.*

[T]he evidence that the . . . Agreement on its face required [the counterclaim defendant] to delete “shirts,” “pants,” and “vests” from its trademark registrations, and that [it] failed to do so, supports a reasonable inference that [its] failure to disclose the Agreement in its . . . PTO application was a willful false material omission.”²²⁸⁰

The court was equally—if improbably—receptive to a second theory of fraud asserted by the counterclaim plaintiff, namely, that the counterclaim defendant had claimed an inaccurate date of first use in one of its applications. Unusually, the court agreed with the counterclaim plaintiff that the absence from the counterclaim defendant’s offerings of pants, shirts, and children’s clothing, which the plaintiff’s registration covered, “supports a reasonable inference that [the counterclaim defendant] had not ‘continuously sold’ [those goods] for three years or more at any time prior to 2012, and that its statements otherwise to the PTO were false.”²²⁸¹ Moreover, “[the counterclaim defendant] has failed to show an absence of clear and convincing evidence as to its knowledge and intent to deceive, and the evidence suggesting that [the counterclaim defendant] made material omissions and false statements to the PTO provides sufficient circumstantial evidence to raise a triable issue of fact as to scienter.”²²⁸²

Likewise, a California federal district court declined to dismiss an allegation of fraudulent procurement resting on two theories.²²⁸³ The first was that the defendant had falsely claimed a date of first use in commerce predating the filing date of the use-based application from which the plaintiff’s registration matured, in support of which the plaintiff alleged that the defendant’s advertising had targeted the residents of only a single state. The defendant’s motion to dismiss invited the court to take judicial notice that the defendant was a federally regulated credit union and that the National Credit Union Administration insured its deposits. The court declined to do so, holding that the question of whether use in commerce had occurred prior to the application’s filing date was a question of fact inappropriately resolved at the pleadings stage.²²⁸⁴

The second theory underlying the plaintiff’s claim of fraudulent procurement was that the defendant had falsely represented it enjoyed the exclusive right to use its mark when, in fact, there were extant third-party uses of confusingly similar marks. Consistent with Board authority on the subject, the defendant argued that the

²²⁸⁰ *Id.*

²²⁸¹ *Exceller Sheepskin & Leather Coat Corp.*, 897 F.3d at 422-23.

²²⁸² *Id.* at 423.

²²⁸³ *See San Diego Cty. Credit Union v. Citizens Equity First Credit Union*, 360 F. Supp. 3d 1039 (S.D. Cal. 2019).

²²⁸⁴ *Id.* at 1049.

uses proffered by the plaintiff were irrelevant in the absence of allegations that the third-party users had grounds for objecting to the registration of the defendant's mark.²²⁸⁵ The court found that argument unconvincing as well, explaining only that “[the plaintiff’s] allegations concerning the existence of third[-]party marks do not warrant dismissal of the claim.”²²⁸⁶

Another California federal district court not only reached a finding of fraudulent procurement, it did so as a matter of law.²²⁸⁷ The summary judgment record before that court established to the court’s satisfaction that the defendants’ claim in the application process of a circa-1933 date of first use of their registered mark predated the actual date by seventy-five years. Having thus concluded that the defendants’ registration rested on a false statement, the court turned to the issue of scienter and concluded that the defendants’ intent to deceive the USPTO was established by deposition testimony from one defendant that none of the defendants had used the registered mark prior to 2008; indeed, the actual registrant did not exist until that year.²²⁸⁸ Because that use transpired before the March 26, 2016, filing date of the defendants’ use-based application, the court might well (and should) have found the inaccuracy immaterial. Nevertheless, and likely because of various additional misconduct by the defendants, the court blithely concluded that “the USPTO granted the registration in reliance on the false statements”²²⁸⁹

Of course, not all attacks on applications and registrations taking place in courts rested on allegations of fraud.²²⁹⁰ For example, the Eleventh Circuit affirmed a district court’s order mandating the cancellation of a registration after concluding that the underlying mark was confusingly similar to that of the plaintiff.²²⁹¹ As the court explained, before its fifth anniversary, a

²²⁸⁵ See, e.g., *Intellimedia Sports Inc. v. Intellimedia Corp.*, 43 U.S.P.Q.2d 1203, 1207 (T.T.A.B. 1997) (holding that unless an applicant knows of rights to the same mark that are “superior or clearly established, e.g., by court decree or prior agreement of the parties, then the applicant has a reasonable basis for believing that no one else has the right to use the mark in commerce, and the applicant’s averment of that reasonable belief in its application declaration or oath is not fraudulent”).

²²⁸⁶ See *San Diego Cty. Credit Union*, 360 F. Supp. 3d at 1051.

²²⁸⁷ See *AECOM Energy & Constr., Inc. v. Ripley*, 348 F. Supp. 3d 1038 (C.D. Cal. 2018), *reconsideration denied*, No. CV 17-5398-RSWL-SSx, 2019 WL 2610953 (C.D. Cal. Apr. 24, 2019), *appeal docketed*, No. 19-55588 (9th Cir. May 2, 2019).

²²⁸⁸ *Id.* at 1060.

²²⁸⁹ *AECOM Energy & Constr.*, 348 F. Supp. 3d at 1060.

²²⁹⁰ See, e.g., *A.V.E.L.A., Inc. v. Estate of Marilyn Monroe, LLC*, 364 F. Supp. 3d 291, 314 (S.D.N.Y. 2019) (granting counterclaim plaintiffs’ motion for summary judgment after concluding that “[t]hroughout their extensive briefing, the [counterclaim defendants] offer no clear evidence to suggest that there are any issues with the [counterclaim plaintiffs’] trademarks that would warrant their cancellation”).

²²⁹¹ See *PlayNation Play Sys., Inc. v. Vex Corp.*, 924 F.3d 1159, 1171 (11th Cir. 2019).

registration on the Principal Register can be cancelled for any reason that would have prevented its issuance in the first place.²²⁹² Because a likelihood of confusion with a prior-used or prior-registered mark is one such ground under Section 2(d) of the Act,²²⁹³ the plaintiff's demonstration of prior rights triggered that remedy.

Similarly, a California federal district court addressed, and then rejected, a non-fraud-based challenge to an intent-to-use application on the theory that the defendant filing it—a subsidiary of Apple Inc., which also was named as a defendant—lacked a bona fide intent to use the applied-for mark in commerce.²²⁹⁴ Entering summary judgment in the defendants' favor, the court noted that “[t]he statute does not define bona fide intent, but the Federal Circuit has held bona fide intent must be proved by objective evidence.”²²⁹⁵ It then found no material dispute that the defendants had adduced just such evidence:

Objective evidence of bona fide intent to use may include licensing agreements. An applicant possessing a brand concept that can embrace the use of the new mark, and the claimed goods or services being within the applicant's immediate capability to implement also constitute persuasive evidence of an applicant's bona fide intent to use.

Here, Apple has produced [a] license agreement for the [applied-for] mark, which covers the applied-for services. Apple has also produced evidence, through the form of contemporaneous registration certificates [covering other marks], that it had the capacity to produce the applied-for services. Viewing this in the context of the strength of Apple's brand, and its breadth of products and services, this evidence is sufficient to demonstrate Apple's bona fide intent to use the [applied-for] mark rather than simply reserve rights in the . . . mark.²²⁹⁶

C. Constitutional Matters

1. Article III Case and Controversies

Both Article III of the U.S. Constitution and the federal Declaratory Judgment Act require federal courts acting under their authority to find the existence of an “actual controversy” before proceeding;²²⁹⁷ moreover, state law causes of action are inevitably

²²⁹² *Id.*

²²⁹³ 15 U.S.C. § 1052(d) (2018).

²²⁹⁴ See *RXD Media, LLC v. IP Application Dev.*, 377 F. Supp. 3d 588 (E.D. Va. 2019), *appeal docketed*, No. 19-1461 (4th Cir. Apr.30, 2019).

²²⁹⁵ *Id.* at 594 (citing *M.Z. Berger & Co. v. Swatch AG*, 787 F.3d 1368, 1376 (Fed. Cir. 2015)).

²²⁹⁶ *Id.* at 594 (citations omitted).

²²⁹⁷ U.S. Const. art. III, § 2, cl. 1; 28 U.S.C. § 2201 (2018).

subject to the same requirements. According to the Supreme Court in *MedImmune, Inc. v. Genentech, Inc.*,²²⁹⁸ whether a particular dispute rises to this level properly should turn on “whether the facts alleged, under all the circumstances, show that there is a substantial controversy . . . of sufficient immediacy and reality to warrant the issuance of a declaratory judgment.”²²⁹⁹

Although the mere filing of an opposition or cancellation action ordinarily will not create an actionable case and controversy between the opposer and the applicant, California federal district courts are unusually receptive to declaratory judgment actions arising from pending inter partes proceedings.²³⁰⁰ One example of this phenomenon came in a case in which the court declined to dismiss a claim for declaratory relief filed by a plaintiff after the defendant petitioned for the cancellation of a registration owned by the plaintiff. In declining to grant the defendant’s motion to dismiss, the court noted that “a pre-suit letter or a notice of opposition filed with the USPTO that lays out the elements of a cause of action for trademark infringement, by itself, is sufficient to create a reasonable apprehension of litigation for infringement, and consequently satisfies the actual controversy requirement under the DJA.”²³⁰¹ Citing averments of likely confusion in the defendant’s petition, the court first concluded that “[i]n this case, the petition for cancellation alleges the elements of a cause of action for trademark infringement.”²³⁰² It then found support for its holding in the defendant’s initial disclosures before the Trademark Trial and Appeal Board, which referenced documents “evidencing the potential for damage to [the petitioner] by reason of *respondent’s use* of [the registered mark] as a purported designation of the origin of services offered by respondent.”²³⁰³ Finally, the court determined that the parties’ converging geographic markets additionally created a reasonable apprehension of litigation.²³⁰⁴

In contrast, a different court determined that, whatever the situation may have been at the outset of litigation, the plaintiffs’ unexpected proffer of a covenant not to sue rendered moot any case and controversy arising from the defendants’ counterclaims.²³⁰⁵ Invoking the Supreme Court’s holding to similar effect in *Already*,

²²⁹⁸ 549 U.S. 118 (2007).

²²⁹⁹ *Id.* at 127 (quoting *Md. Cas. Co. v. Pac. Coal & Oil Co.*, 312 U.S. 270, 273 (1941)) (internal quotation marks omitted).

²³⁰⁰ *See San Diego Cty. Credit Union v. Citizens Equity First Credit Union*, 344 F. Supp. 3d 1147 (S.D. Cal. 2018).

²³⁰¹ *Id.* at 1155.

²³⁰² *Id.* at 1156.

²³⁰³ *Id.* at 1157.

²³⁰⁴ *Id.*

²³⁰⁵ *See Lifeguard Licensing Corp. v. Kozak*, 371 F. Supp. 3d 114 (S.D.N.Y. 2019).

Inc. v. Nike, Inc.,²³⁰⁶ the court evaluated the significance of the covenant under a three-factor test for whether the covenant deprived it of subject-matter jurisdiction over the counterclaims. Those factors were: (1) the language of the covenant itself (which the court did not reproduce in its opinion); (2) whether the covenant covered future, as well as past, activity and goods; and (3) any evidence of intention or lack of intention, on the part of the party asserting jurisdiction, to engage in new activity or to undertake new potentially infringing activities arguably not covered by the covenant.²³⁰⁷ Although placing the burden on the defendants to demonstrate the absence of an actionable case and controversy, the court found the defendants had done just that: “This Court is hard pressed to conceive of any product Defendants could market that would infringe [Plaintiffs’ marks] but would not be covered by the Covenant.”²³⁰⁸ In response to that showing, the defendants made much “of the fact that Plaintiffs offered the Covenant just shy of trial, whereas the covenants in Nike and other cases were offered at earlier points in time,” but, the court found, “that fact is not relevant to the question of whether the Covenant is sufficient in scope to moot the parties’ case or controversy.”²³⁰⁹ It therefore dismissed the defendants’ counterclaims without apparent leave to amend.

In another lawsuit in which a request for declaratory relief failed to make the grade, the parties directly competed in the market for glucomannan-based dietary weight-loss supplements.²³¹⁰ Having received a demand letter objecting to certain claims it had made for its supplements, the plaintiff filed suit seeking a declaratory judgment that it was liable for neither false advertising nor a violation of the federal Food, Drug, and Cosmetic Act (FDCA).²³¹¹ Although the counterclaim defendant moved for summary judgment under the FDCA, the court found that “[n]owhere does [the plaintiff] state that [the defendant] is planning to bring [an FDCA] claim, nor did [the defendant] assert such a claim in its counterclaims.”²³¹² Under the circumstances, the court concluded, “[the plaintiff] fails to carry its burden to show that there is a ‘substantial controversy’ between itself and [the defendant] regarding the [FDCA] ‘of

²³⁰⁶ 568 U.S. 85 (2013).

²³⁰⁷ *Lifeguard Licensing Corp.*, 371 F. Supp. 3d at 124.

²³⁰⁸ *Id.* at 126.

²³⁰⁹ *Id.* at 129.

²³¹⁰ *See Obesity Research Inst., LLC v. Fiber Research Int’l, LLC*, 310 F. Supp. 3d 1089 (S.D. Cal.), *motion to certify denied*, No. 15-cv-00595-BAS-MDD, 2018 WL 1791611 (S.D. Cal. Apr. 16, 2018).

²³¹¹ 21 U.S.C. §§ 301 et seq. (2018).

²³¹² *Obesity Research Inst.*, 310 F. Supp. 3d at 1132.

sufficient immediacy and reality to warrant the issuance of a declaratory judgment.”²³¹³

2. The First Amendment

As has increasingly been the case in recent years, the most successful invocations of the First Amendment right to free speech took place under the rubric first articulated by the Second Circuit in *Rogers v. Grimaldi*.²³¹⁴ As it has come to be applied, *Rogers* protects the titles and content of expressive works against likelihood-of-confusion-based challenges unless one of two circumstances is present: (1) the challenged use has no artistic relevance to the underlying work whatsoever; or (2) if the challenged use does have some artistic relevance, it is explicitly misleading as to the source or content of the work.²³¹⁵ Applications of the *Rogers* test more often than not strongly favor defendants, and so it was over the past year.²³¹⁶

This phenomenon was apparent in an opinion from a California federal district court that expanded *Rogers* beyond its usual confines.²³¹⁷ The plaintiff before that tribunal owned a federal registration of the MASTERMIND mark for audio and video recordings, while the defendants had put out an album titled *Mastermind* and had undertaken a tour under the same name; of perhaps greater significance, the lead defendant had taken on “the persona of ‘Mastermind.’”²³¹⁸ Although the plaintiff might have attempted to distinguish the Ninth Circuit’s past aggressive applications of *Rogers* by characterizing the lead defendant’s use as that of a service mark, he instead argued that *Rogers* did not apply because his claim of infringement sounded in reverse confusion. Unfortunately for the plaintiff, however, the court held that “the *Rogers* test is not barred in this case simply because it involves reverse confusion.”²³¹⁹ It then applied that test to the extreme detriment of the plaintiff, finding as a matter of law that the defendants’ use of the disputed term was artistically relevant to their underlying conduct because “six of the nineteen songs on the album make direct use of ‘mastermind’ in the lyrics, and one song, ‘Thug Cry,’ even directly references the overall album itself by its

²³¹³ *Id.* (quoting *Maryland Cas. Co. v. Pac. Coal & Oil Co.*, 312 U.S. 270, 273 (1941)).

²³¹⁴ 875 F.2d 994 (2d Cir. 1989).

²³¹⁵ *Id.* at 999.

²³¹⁶ *See, e.g.*, *Dr. Seuss Enters. v. ComicMix LLC*, 372 F. Supp. 3d 1101, 1128 (S.D. Cal. 2019) (referencing court’s past grant of defense motion for summary judgment under application of *Rogers*).

²³¹⁷ *See Caiz v. Roberts*, 382 F. Supp. 3d 942, 946 (C.D. Cal. 2019), *appeal dismissed*, No. 19-55611, 2019 WL 6331647 (9th Cir. Aug. 30, 2019).

²³¹⁸ *Id.* at 945.

²³¹⁹ *Id.* at 949.

title—linking the title to its contents”;²³²⁰ “[m]oreover,” the court went on, “Defendants have provided evidence of the use of the term ‘mastermind’ as part of a larger, abstract theme used by artists in hip-hop claiming to be masterminds of music.”²³²¹ Things did not improve for the plaintiff under the second prong of *Rogers*, in connection with which the court found it undisputed that “Plaintiff only provides legal argument that Defendants’ use of ‘Mastermind’ in the same way is explicitly misleading, but points to no evidence indicating that Defendants’ use even ‘implicitly suggest[s]’ that the album is associated with Plaintiff, let alone any evidence of an overt association.”²³²² The defendants therefore were entitled to the dismissal of the plaintiff’s case on summary judgment.

Outside the context of challenges to the titles and content of creative works, the Fifth Circuit sustained a First Amendment-based challenge to a Mississippi statute²³²³ restricting commercial uses of the word “engineer” to those holding engineering licenses from the state.²³²⁴ The plaintiff sued a Mississippi regulatory agency to vindicate its right to use the TIRE ENGINEERS mark for automotive service centers after the agency determined that the mark violated the statute. Although the district court granted the agency’s motion for summary judgment, the Fifth Circuit reversed that disposition under an application of the Supreme Court’s *Central Hudson* intermediate scrutiny test.²³²⁵ The court held that “[a]lthough the Constitution protects commercial speech, that protection is more limited than for most other speech.”²³²⁶ Still, however, the state of Mississippi had failed to carry its “heavy” burden of justifying the restriction.

The court then turned to the three prongs of the *Central Hudson* test, which contemplated that the statute could survive scrutiny if: (1) the asserted governmental interest underlying it was substantial; (2) the statute directly advanced that interest; and (3) the statute was no more extensive than necessary. The court determined that the plaintiff’s use of “engineering” was neither inherently nor actually misleading, but, based on the results of “a telephonic public opinion poll” showing that 47.8 percent of respondents believed the plaintiff performed “engineering services

²³²⁰ *Id.*

²³²¹ *Id.*

²³²² *Id.* at 951 (alteration in original) (quoting *Gordon v. Drape Creative, Inc.*, 909 F.3d 257, 270 (9th Cir. 2018)).

²³²³ Miss. Code Ann. § 73-13-39 (2019).

²³²⁴ See *Express Oil Change, L.L.C. v. Miss. Bd. of Licensure for Prof'l Eng'rs & Surveyors*, 916 F.3d 483 (5th Cir. 2019).

²³²⁵ See *Cent. Hudson Gas & Elec. Corp. v. Pub. Serv. Comm'n of N.Y.*, 447 U.S. 557, 566 (1980).

²³²⁶ *Express Oil Change*, 916 F.3d at 487 (footnote omitted).

for tires,”²³²⁷ it concluded that the plaintiff’s mark was potentially deceptive, therefore triggering a substantial state interest in regulating the mark.²³²⁸ Based on the plaintiff’s failure to contest the issue, the court also held that the statute directly advanced the state’s interest.²³²⁹ Despite this promising beginning, however, the agency failed to carry its burden with respect to the third *Central Hudson* factor both because other states with similar statutes had not challenged the plaintiff’s mark and because the agency had neglected “to address why alternative, less-restrictive means, such as a disclaimer, would not accomplish its stated goal of protecting the public.”²³³⁰

Another successful First Amendment-based argument came in the unlikely context of a criminal prosecution of a motorcycle club for racketeering and conspiracy.²³³¹ Following entry of a guilty verdict by a jury, the federal government sought to seize three collective membership marks owned by the club and used in connection with such goods as clothing, namely the following:²³³²

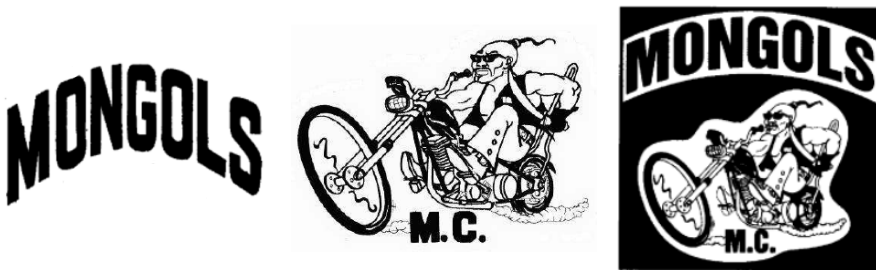

The court rejected the government’s request, concluding as initial matters that “[t]here is no doubt that the display of word marks or symbols on a body or leather vest is pure speech” and that “[c]lothing identifying one’s association with an organization is generally considered expressive conduct entitled to First Amendment protection.”²³³³ Equally to the point, because the government sought to seize the marks at issue because they stoked “fear in the public,” “[t]he requested forfeiture also functions as a content-based restriction on speech” that the government failed to justify.²³³⁴ In the final analysis:

²³²⁷ *Id.* at 490.

²³²⁸ *Id.* at 491-92.

²³²⁹ *Id.* at 492.

²³³⁰ *Id.* at 493.

²³³¹ See *United States v. Mongol Nation*, 370 F. Supp. 3d 1090 (C.D. Cal. 2019).

²³³² *Id.* at 1105.

²³³³ *Id.* at 1112.

²³³⁴ *Id.* at 1114.

[Federal racketeering law] allows for less speech-restrictive means by which the Government can dismantle a criminal entity, such as the seizure of financial assets. Regardless of how “potent” a symbol may be, or how much “fear” a symbol generates, the Government cannot justify the restriction of this speech, especially given the symbols’ purely associative purpose. Though the symbol may at times function as a mouthpiece for unlawful or violent behavior, this is not sufficient to strip speech of its First Amendment protection.²³³⁵

Unsuccessful invocations of the First Amendment by defendants (or by potential defendants pursuing declaratory relief) happened less frequently, but they did occur. For example, after losing its charter from the lead plaintiff, a farmers’ organization, the lead defendant and its principal engaged in a variety of activities creating the impression the defendants remained affiliated with the plaintiffs.²³³⁶ Seeking to avoid what the court deemed infringement and false advertising, the defendants asserted the First Amendment protected their conduct, but the court entered summary judgment against them on that issue as well, holding that “it is well established that the ‘First Amendment does not protect false or misleading commercial speech.’ Defendants’ statements in this case were false or misleading, and as such they are not protected.”²³³⁷

Unusually, even the invocation of the *Rogers* test failed to produce a defense victory in another case.²³³⁸ The counterclaim defendants sold T-shirts emblazoned with images of Marilyn Monroe and the word mark MARILYN, while the counterclaim plaintiffs claimed to own the same mark, the MARILYN MONROE mark, a stylized pair of lips, and Monroe’s persona-based rights. Although the Second Circuit’s opinion in *Rogers* was controlling authority for the New York federal district court hearing the case, the court held that “the *Rogers* test is usually not the appropriate mechanism for examining an ordinary commercial product.”²³³⁹ It additionally agreed with the counterclaim plaintiffs that “any First Amendment concerns are already addressed by the consumer confusion test applicable to commercial products.”²³⁴⁰

²³³⁵ *Id.*

²³³⁶ See *Nat’l Grange of the Order of Patrons of Husbandry v. Cal. Guild*, 334 F. Supp. 3d 1057 (E.D. Cal.), *reconsideration denied sub nom.* *Nat’l Grange v. Cal. Guild*, No. 2:16-cv-0201 WBS DB, 2018 WL 5270563 (E.D. Cal. Oct. 22, 2018), *appeal docketed*, No. 18-16671 (9th Cir. Sept. 5, 2018).

²³³⁷ *Id.* at 1067 (quoting *Amarin Pharma, Inc. v. U.S. Food & Drug Admin.*, 119 F. Supp. 3d 196, 228 (S.D.N.Y. 2015)).

²³³⁸ See *A.V.E.L.A., Inc. v. Estate of Marilyn Monroe, LLC*, 364 F. Supp. 3d 291 (S.D.N.Y. 2019).

²³³⁹ *Id.* at 321.

²³⁴⁰ *Id.* at 322.

“Furthermore,” it held, “even if [the counterclaim defendants] artwork had some artistic value, it is not clear that such value could save it from an infringement claim”²³⁴¹ because:

The [counterclaim plaintiffs] argue that [the lead counterclaim defendant] tricks licensees into a belief that its products are officially endorsed by the individuals holding the rights to the Monroe persona. Even in *Rogers*, the Second Circuit made plain that “[p]oetic license is not without limits. The purchaser of a book, like the purchaser of a can of peas, has a right not to be misled as to the source of the product.”²³⁴²

Thus, “a trial on this question is necessary; the First Amendment, despite all its power, does not resolve this question.”²³⁴³

The uncertain status of *Rogers* in the Seventh Circuit—that court has neither accepted nor rejected the Second Circuit’s analysis—led an Illinois federal district court to decline a defense invitation to dismiss an action for failure to state a claim.²³⁴⁴ The gravamen of the plaintiffs’ claim was that, having left the band Survivor, the defendant had promoted his solo performances using the SURVIVOR mark. Although the defendant invoked *Rogers*, he did so unsuccessfully, with the court holding that “resolution of [the defendant’s] First Amendment argument depends largely upon factual questions that are not properly resolved at the pleading phase.”²³⁴⁵ In substantial part that was because “the dispute boils down to whether [the defendant’s] use of ‘Survivor’ is artistic as opposed to commercial in nature. Here, the complaint plausibly alleges that [the defendant] uses the name ‘Survivor’ to promote his appearances for commercial gain.”²³⁴⁶

3. The Seventh Amendment

The Seventh Amendment provides that “[i]n Suits at common law, where the value in controversy shall exceed twenty dollars, the right of trial by jury shall be preserved, and no fact tried by a jury, shall be otherwise re-examined in any Court of the United States, than according to the rules of the common law.”²³⁴⁷ On its face, the amendment does not address the question of whether the constitutional right to a jury trial extends to the resolution of equitable defenses, but the Eighth Circuit answered that question

²³⁴¹ *Id.*

²³⁴² *Id.* (citation omitted) (quoting *Rogers*, 875 F.2d at 997).

²³⁴³ *Id.*

²³⁴⁴ See *Sullivan v. Bickler*, 360 F. Supp. 3d 778 (N.D. Ill. 2019).

²³⁴⁵ *Id.* at 786.

²³⁴⁶ *Id.*

²³⁴⁷ U.S. Const. amend. VII.

with a resounding no.²³⁴⁸ It did so in a case in which the district court had submitted the plaintiff's claims of infringement and unfair competition to a jury but then had held monetary relief barred by the affirmative defenses of laches and acquiescence. On appeal, the plaintiff argued unsuccessfully that, because the defenses presented "fact-bound inquiries," they properly should have gone to the jury along with the plaintiff's claims of liability.²³⁴⁹ In rejecting that contention, the court of appeals concluded instead that "[t]he 'determination of equitable defenses . . . is a matter for the court to decide, not the jury.'"²³⁵⁰

In another interpretation of the Seventh Amendment, the Eleventh Circuit addressed the perennial question of whether the amendment guarantees a jury trial in a case in which the plaintiff seeks an equitable accounting of the defendant's profits but not the legal remedy of an award of its own actual damages.²³⁵¹ The Supreme Court's opinion in *Dairy Queen, Inc. v. Wood*,²³⁵² a case presenting a standard breach-of-contract claim as well as one for service mark infringement, has led some courts to answer that question affirmatively,²³⁵³ but the Eleventh Circuit did not make that error. It turned first to the Supreme Court's two-part test for determining the amendment's applicability:

To determine whether a statutory action is more similar to cases that were tried in courts of law than to suits tried in courts of equity or admiralty, the Court must examine both the nature of the action and of the remedy sought. First, we compare the statutory action to 18th-century actions brought in the courts of England prior to the merger of the courts of law and equity. Second, we examine the remedy sought and determine whether it is legal or equitable in nature.²³⁵⁴

After a scholarly discussion of the issue, the court held with respect to the first prong of the test that "when the Seventh Amendment was ratified trademark rights had 'been long recognized by the common law and the chancery courts of England,' [and] this part of

²³⁴⁸ See *Sturgis Motorcycle Rally, Inc. v. Rushmore Photo & Gifts, Inc.*, 908 F.3d 313 (8th Cir. 2018), *on remand*, 129 U.S.P.Q.2d 1392 (D.S.D. 2019).

²³⁴⁹ *Id.* at 343.

²³⁵⁰ *Id.* (quoting *Smith v. World Ins. Co.*, 38 F.3d 1456, 1462 (8th Cir. 1994)).

²³⁵¹ See *Hard Candy, LLC v. Anastasia Beverly Hills, Inc.*, 921 F.3d 1343 (11th Cir. 2019).

²³⁵² 369 U.S. 469 (1962).

²³⁵³ See, e.g., *Oxford Indus. v. Hartmarx Corp.*, 15 U.S.P.Q.2d 1648, 1654 (N.D. Ill. 1990) (recognizing right to jury trial on request for accounting because "an award of profits in the trademark context is more like an award of damages than restitution").

²³⁵⁴ *Hard Candy*, 921 F.3d at 1354 (quoting *Tull v. United States*, 481 U.S. 412, 417-18 (1987)).

the Supreme Court’s test is indeterminate.”²³⁵⁵ The second prong, however, provided “substantially more guidance,” because “[t]he remedy sought by [the plaintiff], an accounting and disgorgement of profits, was historically a matter for courts of equity,”²³⁵⁶ and that principle was apparent in opinions arising from trademark disputes as well as those in other areas of the law.²³⁵⁷ Properly recognizing that the *Dairy Queen* Court considered the purported claim for an accounting before it actually to be one for an award of damages,²³⁵⁸ the Eleventh Circuit ultimately opined that “a claim for an accounting and disgorgement of profits under the Lanham Act is equitable in nature and, therefore, . . . the Seventh Amendment’s guarantee of a jury trial does not apply.”²³⁵⁹

The correctness of the Eleventh Circuit’s holding on this point did not stop other courts from referring accountings to juries.²³⁶⁰ For example, having conducted a jury trial on the liability of the defendant before it, a Texas federal district court rejected the defendant’s post-trial attack on the resulting calculation.²³⁶¹ And a California federal district court noted in otherwise entering summary judgment in the lead plaintiff’s favor that “[t]he parties are in agreement that a jury trial will be needed in order to determine the amount of damages [the lead plaintiff] is entitled to.”²³⁶² Only one court referring a request for an accounting to a jury attempted to justify that step under *Dairy Queen*, and it did so after the fact in denying a post-trial attack on the outcome:

[I]n deciding that the plaintiff in a trademark infringement claim who sought the remedy of an “equitable accounting” of the defendant’s profits was entitled to a jury trial, [the *Dairy Queen* Court] stated that determining whether a remedy was

²³⁵⁵ *Id.* at 1355 (quoting *United States v. Steffens (The Trade-Mark Cases)*, 100 U.S. 82, 92 (1879)).

²³⁵⁶ *Id.*

²³⁵⁷ *Id.* at 1355-57.

²³⁵⁸ *See* 369 U.S. at 477-78 (“The respondents’ contention that this money claim is ‘purely equitable’ is based primarily upon the fact that their complaint is cast in terms of an ‘accounting,’ rather than in terms of an action for ‘debt’ or ‘damages.’ But the constitutional right to trial by jury cannot be made to depend upon the choice of words used in the pleadings.”).

²³⁵⁹ *Hard Candy*, 908 F.3d at 1358.

²³⁶⁰ *See, e.g.,* *Talent Mobile Dev., Inc. v. Headios Grp.*, 382 F. Supp. 3d 953, 963 (C.D. Cal. 2019) (declining to overturn accounting of profits by jury), *appeal docketed*, No. 19-55258 (9th Cir. Mar. 5, 2019); *Evoqua Water Techs. LLC v. M.W. Watermark, LLC*, 128 U.S.P.Q.2d 1775, 1782 (W.D. Mich. 2018) (same).

²³⁶¹ *See* *Ill. Tool Works Inc. v. Rust-Oleum Corp.*, 346 F. Supp. 3d 951, 958-59 (S.D. Tex. 2018), *appeal docketed*, No. 19-20210 (5th Cir. Apr. 4, 2019).

²³⁶² *See* *Nat’l Grange of the Order of Patrons of Husbandry v. Cal. Guild*, 334 F. Supp. 3d 1057, 1070 (E.D. Cal.), *reconsideration denied sub nom. Nat’l Grange v. Cal. Guild*, No. 2:16-cv-0201 WBS DB, 2018 WL 5270563 (E.D. Cal. Oct. 22, 2018), *appeal docketed*, No. 18-16671 (9th Cir. Sept. 5, 2018).

equitable or legal—and thus whether or not the constitutional jury trial right adhered—did not depend on word choice but on the substantive question whether there was “the absence of an adequate remedy at law.” The Court explained that, when the remedy sought was “a money claim,” it was a “rare case” where no remedy at law would be available, limited to those instances where “the accounts between the parties are of such a complicated nature that only a court of equity can satisfactorily unravel them.” *Dairy Queen* directs the outcome here. Although disgorgement may have some history in equity, [the plaintiffs’] claim required nothing more than the adding up of unjustly earned profits, a task well within the ken of the jury.²³⁶³

4. The Eighth Amendment

The relationship between federal trademark law and the Eighth Amendment²³⁶⁴ is not readily apparent, but the two intersected in the unlikely context of a criminal racketeering prosecution.²³⁶⁵ Having secured guilty verdicts against the defendant, the Mongol Nation motorcycle club (as well as against a number of its members), the government sought the forfeiture of the defendant’s assets, including collective membership marks owned by the club.²³⁶⁶ As the court summarized the basis of the government’s forfeiture petition, “[t]he collective membership marks are ‘potent emblem[s]’ used to ‘generate fear among the general public,’ and the Government has sought orders to prevent use of ‘the trademark to create an atmosphere of fear through public display.’”²³⁶⁷

Unfortunately for the government, and whatever the merits of the requested seizure may have been from a purely statutory perspective, the court held that relief barred by the Eighth Amendment’s prohibition on cruel and unusual punishment. According to the court, “[t]he Government has sought to punish the Mongol Nation by proceeding against it criminally, *in personam*; the forfeiture is punitive, and the test for the excessiveness of a punitive forfeiture involves solely a proportionality determination.”²³⁶⁸ Undertaking that determination, the court found that “[f]orfeiture of the rights associated with and appurtenant to collective

²³⁶³ *De Simone v. VSL Pharm., Inc.*, 395 F. Supp. 3d 617, 636-37 (D. Md. 2019) (quoting *Dairy Queen*, 369 U.S. at 477-78), *appeal docketed sub nom De Simone v. Alfasigma USA, Inc.*, No. 19-1731 (4th Cir. July 12, 2019), and *appeal docketed sub nom. De Simone v. Leadiant Biosciences, Inc.*, No. 19-1762 (4th Cir. July 22, 2019).

²³⁶⁴ U.S. Const. amend. VIII.

²³⁶⁵ *See United States v. Mongol Nation*, 370 F. Supp. 3d 1090 (C.D. Cal. 2019).

²³⁶⁶ *Id.* at 1096.

²³⁶⁷ *Id.* at 1097.

²³⁶⁸ *Id.* at 1117.

membership marks is harsh and grossly disproportionate.”²³⁶⁹ Although acknowledging that the jury had convicted the defendant of a “serious offense,”²³⁷⁰ it concluded:

[T]he collective membership marks were acquired in 1969 upon first use and have been maintained through continuous use for decades. The symbols have immense intangible, subjective value to the Mongol Nation and its members. Indeed, numerous members have permanently tattooed the images on their backs and elsewhere. . . . Individual Mongol Nation members may have displayed the symbols while committing crimes, but the defendant association did not use the rights associated with the collective membership marks in furtherance of those acts. . . . And the collective membership marks are not the fruits of any illegal activity. They were legally acquired via first use in 1969 and were legally maintained via continuous use.²³⁷¹

Especially “[g]iven the punishments already secured by the United States [in connection with its prosecution of the defendant’s individual members], the forfeiture of the collective membership marks is grossly disproportionate to the gravity of the RICO conspiracy”²³⁷² and therefore would violate the Eighth Amendment’s protection.

D. Procedural Matters

1. Federal Subject-Matter Jurisdiction

Opinions addressing the requirements for federal subject-matter jurisdiction were rare outside the contexts of disputes over arbitrability²³⁷³ and the existence of actionable cases and controversies between parties.²³⁷⁴ Nevertheless, Section 37 of the Act—which makes available the possible remedy of cancellation in any action involving a registered mark—led to the usual holding that, because it does not create an independent cause of action, that section cannot itself be the basis of an exercise of federal subject-

²³⁶⁹ *Id.* at 1119.

²³⁷⁰ *Id.*

²³⁷¹ *Id.*

²³⁷² *Id.* at 1120.

²³⁷³ See *Landau v. Eisenberg*, 922 F.3d 495, 498 (2d Cir. 2019) (affirming district court’s exercise of subject-matter jurisdiction over dispute originally addressed by rabbinical court); *Armor All/STP Prods. Co. v. TSI Prods., Inc.*, 337 F. Supp. 3d 156, 167 (D. Conn. 2018) (exercising subject-matter jurisdiction over question of arbitrability in the first instance).

²³⁷⁴ See *Lifeguard Licensing Corp. v. Kozak*, 371 F. Supp. 3d 114, 129 (S.D.N.Y. 2019) (finding that covenant not to sue precluded exercise of federal subject-matter jurisdiction).

matter jurisdiction.²³⁷⁵ Consequently, if a litigant invoking Section 37 fails to demonstrate its priority of rights vis-à-vis a registered mark, its request for cancellation of the mark's registration necessarily will fail.²³⁷⁶

Other disputes over the existence or nonexistence of federal subject-matter jurisdiction produced holdings that it existed.²³⁷⁷ One such dispute arose from a plaintiff's decision to bring its claims in federal court after initially asserting them in an eventually-dismissed action in Connecticut state court.²³⁷⁸ Seeking the dismissal of the federal court action under Federal Rule of Civil Procedure 12(b)(1),²³⁷⁹ the defendant bizarrely accused the plaintiff of the improper removal of the original action to federal court. Not surprisingly, the court held that "Defendant's arguments of dismissing under Rule 12(b)(1), even generously construed, are entirely meritless."²³⁸⁰ It explained: "[T]his case does not involve removal. Granted, plaintiff sought to bring this claim in state court, but its request for leave to amend its complaint to include [a] cybersquatting claim was denied by the Connecticut state court."²³⁸¹ Moreover, although the defendant argued that the absence of a federal cause of action from the original complaint in state court precluded the existence of federal subject-matter jurisdiction over the subsequent one in federal court—which did include an ACPA claim—the court held instead that "[a]lthough there may be a factual nexus between the two lawsuits, they are procedurally distinct. The cause of action that plaintiff has pled before this Court is based solely on a federal statute, the AntiCybersquatting Consumer Protection Act. The case therefore presents a federal question."²³⁸² The court then rejected the defendant's final argument that a prior agreement between the parties governed by Connecticut law prevented the court from entertaining the action because the plaintiff's cybersquatting action did not arise from the prior agreement and, additionally, because "even if the clause were applicable here, it would govern only which state's law this Court

²³⁷⁵ See *My Pillow, Inc. v. LMP Worldwide, Inc.*, 331 F. Supp. 3d 920 (D. Minn. 2018).

²³⁷⁶ *Id.* at 933.

²³⁷⁷ See, e.g., *Rush v. Hillside Buffalo, LLC*, 314 F. Supp. 3d 477, 483 (W.D.N.Y. 2018) (denying motion to dismiss and explaining that "[a]lthough Plaintiff's allegations invoking the Lanham Act are somewhat unclear and not wholly fleshed out, in reviewing the Complaint as a whole the Court preliminarily finds that it has subject matter jurisdiction to entertain this action on the basis of federal question jurisdiction").

²³⁷⁸ See *McAllister Olivarius v. Mermel*, 298 F. Supp. 3d 661 (S.D.N.Y. 2018).

²³⁷⁹ Fed. R. Civ. P. 12(b)(1).

²³⁸⁰ *McAllister Olivarius*, 298 F. Supp. 3d at 667.

²³⁸¹ *Id.*

²³⁸² *Id.* at 668 (citation omitted).

must apply and therefore would not bar this Court's exercise of jurisdiction."²³⁸³

2. Appellate Jurisdiction

Federal Rule of Appellate Procedure 3(c)(1)(B) requires that a notice of appeal "designate the judgment, order, or part thereof being appealed."²³⁸⁴ Having lost its case on summary judgment, one plaintiff moved the court to reconsider that outcome and, when the motion failed, the plaintiff noticed an appeal to the First Circuit that mentioned only the denial of the motion for reconsideration.²³⁸⁵ When the plaintiff filed an appellate brief that also addressed the defendants' successful summary judgment motion, the defendants argued that, under Rule 3(c)(1)(B), the plaintiff's incomplete notice of appeal deprived the First Circuit of jurisdiction over that aspect of the plaintiff's appeal.

The appellate court acknowledged that its past opinions on the subject "certainly accommodate a robust application of waiver in circumstances such as this one. We have several times ruled that we do not have jurisdiction to review an underlying judgment when the notice of appeal designates only the district court's denial of a motion for reconsideration."²³⁸⁶ Nevertheless, the same case law featured "some looseness in the joints" that ultimately allowed the plaintiff to prevail, at least with respect to the question of appellate jurisdiction.²³⁸⁷ According to the court's reading of the record below, the district court's grant of the defendants' motion for summary judgment and its denial of the plaintiff's motion for reconsideration turned on the same trademark-based issues. For that reason, "deeming the notice of appeal sufficient to preserve for appellate review the overlapping issues of law raised by the summary judgment ruling and the [reconsideration] ruling will cause no unfair prejudice to the appellees in this case or to the administration of the appeal."²³⁸⁸

²³⁸³ *Id.* at 668.

²³⁸⁴ Fed. R. App. P. 3(c)(1)(B).

²³⁸⁵ *See* *Comite Fiestas De La Calle San Sebastian, Inc. v. Soto*, 925 F.3d 528 (1st Cir. 2019).

²³⁸⁶ *Id.* at 531.

²³⁸⁷ *Id.*

²³⁸⁸ *Id.* at 532.

This holding notwithstanding, the court did reject the plaintiff's attempt to pursue a different argument on appeal, namely, that the defendants (a municipality and certain of its employees) had violated the First Amendment by retaliating against the plaintiff based on the plaintiff's criticism of the defendants. Because the plaintiff had failed to move for reconsideration of the district court's summary dismissal of that claim, the notice of appeal could not be fairly read to cover it. *Id.* at 533.

3. Standing

To establish its standing to pursue a cause of action for purposes of Article III of the Constitution, a plaintiff must credibly aver a redressable injury attributable to the defendant's conduct;²³⁸⁹ it must then also satisfy any additional requirements for standing under the particular cause of action under which it is proceeding. In *Lexmark International v. Static Control Components, Inc.*,²³⁹⁰ a case presenting allegations of false advertising under Section 43(a) of the Act, the Supreme Court established a two-part test for standing. First, the plaintiff's interest must be within the zone of interests the Act is intended to protect.²³⁹¹ And, second, the plaintiff must allege that its injuries were proximately caused by defendant's deceptive practices.²³⁹² Not surprisingly, *Lexmark* has played a major role in the resolution of the standing inquiry in false advertising disputes since its issuance; somewhat less predictably, though, the Supreme Court's analysis also has appeared in many, but not all, opinions addressing other causes of action under the Act.

a. Opinions Finding Standing

One court hearing cross-motions for summary judgment recognized the standing of a counterclaim plaintiff under Section 43(a) to challenge allegedly false statements concerning glucomannan-based weight-loss supplements.²³⁹³ As part of a larger transaction, the counterclaim plaintiff had acquired a third party's rights to bring suit against the counterclaim defendant based on the latter's misrepresentations, and that necessitated a threshold holding by the court that the assignment was valid as a matter of Nevada law.²³⁹⁴ Reviewing the salient language of the transaction document, the court first concluded that "[t]his provision [assigning the right to sue] is clear and unambiguous, and, though it is limited in scope, the Court finds that it encompasses the [counterclaim

²³⁸⁹ See generally *Lujan v. Defenders of Wildlife*, 504 U.S. 555, 560-61 (1992).

²³⁹⁰ 134 S. Ct. 1377 (2014).

²³⁹¹ *Id.* at 1388.

²³⁹² *Id.* at 1390.

²³⁹³ See *Obesity Research Inst., LLC v. Fiber Research Int'l, LLC*, 310 F. Supp. 3d 1089 (S.D. Cal.), *motion to certify denied*, No. 15-cv-00595-BAS-MDD, 2018 WL 1791611 (S.D. Cal. Apr. 16, 2018).

²³⁹⁴ Reviewing the salient language of the transaction document, the court first concluded that "[t]his provision [assigning the right to sue] is clear and unambiguous, and, though it is limited in scope, the Court finds that it encompasses the [counterclaim plaintiff's] Lanham Act false advertising claim." *Id.* at 1109. It then rejected the counterclaim defendant's argument that Nevada law prohibited the assignment of tort claims because the prohibition in question applied only to tort claims arising from alleged personal injuries. *Id.* at 1109-10.

plaintiff's] Lanham Act false advertising claim."²³⁹⁵ It then rejected the counterclaim defendant's argument that Nevada law prohibited the assignment of tort claims because the prohibition in question applied only to tort claims arising from alleged personal injuries.²³⁹⁶

Having resolved that issue, the court turned to the counterclaim defendant's argument that the counterclaim plaintiff lacked standing under both Article III of the Constitution and Section 43(a). One basis of the counterclaim plaintiff's claims was the allegation that the counterclaim defendant had misrepresented the results of studies of the effectiveness of the glucomannan produced by the counterclaim plaintiff's predecessor in a manner suggesting that the results applied with equal force to the counterclaim defendant's supplements, which contained glucomannan produced by a third party. Other alleged misrepresentations related to the counterclaim defendant's descriptions of one study, namely, that a "major university" had conducted it and that participants had not been asked to change their lifestyle. Finally, the counterclaim plaintiff accused the counterclaim defendant of falsely representing that its supplements contained "pure glucomannan" but "no known allergens."

The court held that these allegations established the counterclaim plaintiff's standing under the Constitution and the Act. With respect to the former, the court concluded: (1) "[the counterclaim plaintiff] provides support to show that [its predecessor] was injured in fact by losing opportunities to expand into the weight loss supplement market through its distributors and failing to realize gains from its research and development investments";²³⁹⁷ (2) "[the counterclaim plaintiff] has met its burden to show that [its predecessor's] injuries were caused by [the counterclaim defendant's] actions flowing directly from the allegedly false advertisements relating to the . . . studies";²³⁹⁸ and (3) [the counterclaim plaintiff] has shown that the injury is likely redressed by a favorable decision as [the counterclaim plaintiff] seeks monetary and injunctive relief for [its predecessor's] damages."²³⁹⁹ And, with respect to the latter, the court determined that the counterclaim plaintiff enjoyed standing under the "not . . . particularly demanding" test established by *Lexmark*²⁴⁰⁰ because: (1) "[the counterclaim plaintiff's predecessor] invested millions of dollars into developing its products and sought to expand its product

²³⁹⁵ *Id.* at 1109.

²³⁹⁶ *Id.* at 1109-10.

²³⁹⁷ *Id.* at 1112.

²³⁹⁸ *Id.*

²³⁹⁹ *Id.*

²⁴⁰⁰ *Id.* at 1114.

distribution, including within the United States”;²⁴⁰¹ (2) “while it is not a direct competitor with [the counterclaim defendant], [the predecessor] also distributes glucomannan, which is the main ingredient in [the counterclaim defendant’s product], and supplies glucomannan to [the counterclaim plaintiff], who seeks to compete with [the counterclaim defendant’s product] in the glucomannan supplement market”;²⁴⁰² and (3) [the counterclaim defendant] advertises [its product]—which no longer contains [the predecessor’s] glucomannan—using a clinical study that analyzed [the predecessor’s glucomannan].”²⁴⁰³ Under those circumstances, the court found as a matter of law that “[the counterclaim plaintiff] met its burden to show that [its predecessor] likely suffered an injury to a commercial interest in reputation or sales.”²⁴⁰⁴

Lexmark played a key role in a different court’s finding that a spring water supplier had standing to challenge representations by a direct competitor and the competitor’s distributors that the water they sold also came from springs when, in fact, it allegedly was mere well water.²⁴⁰⁵ The court easily recognized the plaintiff’s standing to challenge the direct competitor’s advertising:

Because Plaintiff and [the other water supplier] are direct competitors, Plaintiff’s loss of sales flows directly from, and is thus proximately caused by, [the competitor’s] violation of the statute. The ‘classic Lanham Act false-advertising claim’ is one in which ‘one competitor directly injures another by making false statements about his own goods or the competitor’s goods and thus inducing customers to switch.’²⁴⁰⁶

This was all the more true in light of the plaintiff’s identification of particular distributors that had dropped its water in favor of the competitive distributor’s water, as well as its averments that the competitor had instigated regulatory investigations of the plaintiff’s water, which the court held adequate to allege reputational damage creating standing.²⁴⁰⁷

The plaintiff’s standing to challenge the allegedly false claims by the other defendants that the water they had acquired from the competitive distributor was spring water presented a different question. As the court summarized the issue, “[t]he proximate cause analysis is more complex as to the [other] Defendants because

²⁴⁰¹ *Id.* at 1115.

²⁴⁰² *Id.*

²⁴⁰³ *Id.*

²⁴⁰⁴ *Id.*

²⁴⁰⁵ See *Frompovic v. Niagara Bottling, LLC*, 337 F. Supp. 3d 498 (E.D. Pa. 2018).

²⁴⁰⁶ *Id.* at 506 (quoting *Lexmark*, 572 U.S. at 137).

²⁴⁰⁷ *Id.* at 507.

Plaintiff does not directly compete with them. Rather, the [other] Defendants are Plaintiff's potential consumers: He seeks to sell his water to bottlers, who would then sell to consumers."²⁴⁰⁸ Crediting the plaintiff's averments that two of those defendants had once sourced their water from the plaintiff, the court held that the preexisting commercial relationship between the plaintiff and those defendants rendered it plausible that those defendants would have continued to purchase water from the plaintiff absent the defendants' scheme to mislabel their water as having come from springs. The court therefore allowed the plaintiff's case to proceed against those two defendants but not against other distributors lacking a prior relationship with the plaintiff.²⁴⁰⁹

An additional reported opinion finding standing in a false advertising action was notable for mentioning neither *Lexmark* nor the test for standing arising from that opinion.²⁴¹⁰ The plaintiff in the action producing that opinion manufactured medical dermatology products at the time it filed suit against the defendants, but the plaintiff's parent corporation divested itself of certain portions of its business to another member of its corporate family during the pendency of the litigation. Following the divestiture, the parties no longer targeted goods toward the same patients, and that circumstance led the defendants to challenge the plaintiff's continued standing to prosecute the action. The court delved into the summary judgment record assembled by the parties before rejecting the defendants' argument. From that record, it determined that the plaintiff continued to distribute the pharmaceutical products at issue and also indirectly benefitted from earnings tied to the sales of those products. Those circumstances, the court found, conferred standing on the plaintiff to prosecute its action on a going-forward basis.²⁴¹¹

b. Opinions Declining to Find Standing

Two reported opinions rejecting claims of standing did so in cases brought by licensees, rather than owners, of marks. The first came in an appeal to the Eleventh Circuit from a district court opinion dismissing on summary judgment a claim for unfair competition under Section 43(a).²⁴¹² That result held below because the license governing the plaintiff's use of the disputed mark recited that the licensor retained all ownership rights and the right to

²⁴⁰⁸ *Id.*

²⁴⁰⁹ *Id.* at 509-10.

²⁴¹⁰ See *Allergan USA, Inc. v. Prescribers Choice, Inc.*, 364 F. Supp. 3d 1089 (C.D. Cal. 2019).

²⁴¹¹ *Id.* at 1103.

²⁴¹² See *Kroma Makeup EU, LLC v. Boldface Licensing + Branding, Inc.*, 920 F.3d 704 (11th Cir.), *cert. denied sub nom.* *Kroma Makeup EU, LLC v. Kardashian*, 140 S. Ct. 381 (2019).

enforce those rights against violations by third parties, subject only to the duty to reimburse the licensee for any damages caused by those violations. Citing *Lexmark*, the appellate court held that, “[t]o start, ‘a statutory cause of action extends only to plaintiffs whose interests fall within the zone of interest protected by the law invoked.’”²⁴¹³ It then affirmed the district court’s entry of summary judgment because:

Here, applying the licensing agreement to this inquiry is a straightforward exercise. The plain language of the agreement demonstrates the parties’ intent for [the licensor] to retain all ownership and enforcement rights. [The licensee]—while it may have other rights under the agreement—does not possess the ability to assert its rights in the mark in this proceeding.²⁴¹⁴

The second opinion came from a California federal district court.²⁴¹⁵ In the dispute before it, a defense motion for summary judgment targeted a Section 32 cause of action for infringement and a Section 43(c) cause of action for likely dilution asserted by a plaintiff that was a licensee of the mark it sought to protect. Although holding the defendants liable for having violating the licensor’s rights as a matter of law, the court held that the licensee lacked standing to assert anything more than a cause of action for unfair competition under Section 43(a): “[The defendants] [are] correct that only a mark’s owner has standing under federal and [California] law to bring claims for trademark dilution and infringement.”²⁴¹⁶

In a less conventional factual scenario, a long-standing battle between rival farmers’ organizations produced a holding that one of the plaintiffs lacked standing to prosecute its claims for infringement and unfair competition.²⁴¹⁷ The defendants were a disaffiliated state chapter of the lead plaintiff and the former chapter’s leadership while the other plaintiff was a corporation formed after the disaffiliation of the defendants from the lead plaintiff. As the court summarized the summary judgment record on the subject, “[t]his corporation [the second plaintiff] has no bank

²⁴¹³ *Id.* at 709 (quoting *Lexmark*, 572 U.S. at 129).

²⁴¹⁴ *Id.*

²⁴¹⁵ *See Gianni Versace, S.p.A. v. Versace 19.69 Abbigliamento Sportivo SRL*, 328 F. Supp. 3d 1007 (N.D. Cal. 2018), *appeal dismissed*, No. 19-15188, 2019 WL 2005744 (9th Cir. Apr. 17, 2019).

²⁴¹⁶ *Id.* at 1031.

²⁴¹⁷ *See Nat’l Grange of the Order of Patrons of Husbandry v. Cal. Guild*, 334 F. Supp. 3d 1057 (E.D. Cal.), *reconsideration denied sub nom. Nat’l Grange v. Cal. Guild*, No. 2:16-cv-0201 WBS DB, 2018 WL 5270563 (E.D. Cal. Oct. 22, 2018), *appeal docketed*, No. 18-16671 (9th Cir. Sept. 5, 2018).

account records and it does not collect dues.”²⁴¹⁸ Attempting to salvage the second plaintiff’s standing, the plaintiffs argued they sought to vindicate the rights of their organization as a whole and not those of any individual company. The court objected to the suggestion that an undifferentiated “amorphous entity” such as that posited by the plaintiffs could have standing,²⁴¹⁹ and it was equally unconvinced that the moribund nature of the second plaintiff’s activities qualified it to bring suit. It therefore entered summary judgment in the defendants’ favor dismissing the second plaintiff from the action.²⁴²⁰

c. Opinions Deferring Resolution of the Standing Inquiry

As always, some courts weighed, but then declined to accept as a matter of law, defendants’ claims that their opponents lacked standing.²⁴²¹ In one case, having been accused of having made false representations concerning the characteristics of its goods and those of its competitors, a defendant manufacturer of single-server coffee brewers and the cartridges used in them disputed the competitors’ standing to challenge representations it allegedly had made to retail customers (as opposed to end consumers).²⁴²² According to the defendant, the plaintiffs had failed to aver sufficiently how those representations were the proximate cause of any damages suffered by the plaintiffs. The court was in no mood to entertain that argument; instead, citing allegations that the defendant’s representations concerning the simplicity of its goods had led to the loss of retail customers, it denied the defendant’s motion to dismiss as to the plaintiffs’ Section 43(a) causes of action.²⁴²³ It then reached the same conclusion with respect to their claims under New York and Illinois law.²⁴²⁴

Opinions declining to resolve plaintiffs’ standing on motions for summary judgment occur relatively infrequently, but a Florida federal district court took that step in denying a defense motion for summary judgment on the issue.²⁴²⁵ The prevailing plaintiffs—at least at that stage of the proceeding—were affiliated timeshare

²⁴¹⁸ *Id.* at 1065.

²⁴¹⁹ *Id.* at 1065.

²⁴²⁰ *Id.*

²⁴²¹ *See, e.g.*, *Steer Mach. Tool & Die Corp. v. SS Niles Bottle Stoppers, LLC*, 331 F. Supp. 3d 429, 433-34 (M.D. Pa. 2018) (holding that plaintiff had adequately established its standing to challenge alleged false advertising and passing off by direct competitor).

²⁴²² *See In re Keurig Green Mountain Single-Serve Coffee Antitrust Litig.*, 383 F. Supp. 3d 187 (S.D.N.Y. 2019).

²⁴²³ *Id.* at 249.

²⁴²⁴ *Id.* at 251.

²⁴²⁵ *See Diamond Resorts Int’l, Inc. v. Aaronson*, 371 F. Supp. 3d 1088 (M.D. Fla. 2019).

developers managing “over 420 membership resorts worldwide.”²⁴²⁶ The defendants were an attorney and law firm specializing in assisting timeshare owners to escape their contracts. According to the plaintiffs, the defendants solicited clients through false statements concerning the plaintiffs’ business practices and the rights of timeshare owners generally. “Thus,” the court noted in summarizing the plaintiffs’ allegations, “timeshare members have ceased payments under their Timeshare Contracts, and occasionally [the plaintiffs have] faced baseless arbitration proceedings.”²⁴²⁷

Challenging the plaintiffs’ standing under Section 43(a), the defendants argued that, because the plaintiffs had waived their claims for actual damages tied to reputational harm, they no longer fell within the zone of interests protected by the statute, but the court concluded instead that “[g]iven the Subject Advertisements, particularly those targeted at [the plaintiffs], the Court finds that a reasonable jury could find that any false accusations in the Subject Advertisements have harmed [the plaintiffs’] reputation.”²⁴²⁸ The court then rejected the defendants’ improbable theory that the monetary losses claimed by the plaintiffs were not actual damages but were more accurately characterized as “only an interest in ‘accounts receivables,’” concerning which the court found that “[a]bsent authority to the contrary, . . . these unpaid obligations, coupled with the lost customers associated with these unpaid obligations, constitute ‘lost sales’ that are a sufficient harm to maintain this false advertising claim.”²⁴²⁹ The plaintiffs’ claim therefore survived until trial.

4. Personal Jurisdiction

Depending on the extent of a defendant’s contacts with the forum state, an exercise of personal jurisdiction over it “can be either ‘general’ or ‘specific.’”²⁴³⁰ As one court explained, under “general or ‘all-purpose’ jurisdiction, courts located where defendants are at ‘at home’ may exercise jurisdiction over any claim against them.”²⁴³¹ In contrast, the propriety of an exercise of personal jurisdiction over a nonresident defendant by the courts of a particular state traditionally has turned on whether: (1) the forum state’s long-arm statute confers personal jurisdiction over the defendant; and (2) an

²⁴²⁶ *Id.* at 1093.

²⁴²⁷ *Id.* at 1094.

²⁴²⁸ *Id.* at 1102.

²⁴²⁹ *Id.*

²⁴³⁰ *San Diego Cty. Credit Union v. Citizens Equity First Credit Union*, 325 F. Supp. 3d 1088, 1095 (S.D. Cal. 2018); *see also Sullivan v. Bickler*, 360 F. Supp. 3d 778, 783 (N.D. Ill. 2019); *Nat’l Women’s Political Caucus, Inc. v. Metro. Louisville Women’s Political Caucus, Inc.*, 359 F. Supp. 3d 13, 18 (D.D.C. 2019).

²⁴³¹ *IMAPizza, LLC v. At Pizza Ltd.*, 334 F. Supp. 3d 95, 109 (D.D.C. 2018).

exercise of jurisdiction would comport with the Due Process Clause of the Fourteenth Amendment.²⁴³² If the reach of the state long-arm statute in question is coextensive with due process, only the constitutional analysis need take place.²⁴³³ That analysis typically turns on the application of a tripartite test:

(1) The non-resident defendant must purposefully direct his activities or consummate some transaction with the forum or resident thereof; or perform some act by which he purposefully avails himself of the privilege of conducting activities in the forum, thereby invoking the benefits and protections of its laws; (2) the claim must be one which arises out of or relates to the defendant's forum-related activities; and (3) the exercise of jurisdiction must comport with fair play and substantial justice, i.e. it must be reasonable.²⁴³⁴

In addition to this traditional analysis, plaintiffs faced with non-U.S. defendants have in recent years turned to Federal Rule of Civil Procedure 4(k)(2) as an alternative means of establishing the propriety of an exercise of jurisdiction. That rule provides that:

For a claim that arises under federal law, serving a summons or filing a waiver of service establishes personal jurisdiction over a defendant if:

- (A) the defendant is not subject to jurisdiction in any state's courts of general jurisdiction; and
- (B) exercising jurisdiction is consistent with the United States Constitution and laws.²⁴³⁵

a. Opinions Exercising Personal Jurisdiction

Even in cases in which defendants did not consent to exercises of personal jurisdiction over them,²⁴³⁶ that outcome still held. For example, in a declaratory judgment action for noninfringement, the acquisition by an Illinois-based credit union of a smaller California-

²⁴³² See, e.g., *Am. Dairy Queen Corp. v. W.B. Mason Co.*, 129 U.S.P.Q.2d 1291, 1293 (D. Minn. 2019); *Haas Outdoors, Inc. v. Dryshod Int'l, LLC*, 347 F. Supp. 3d 266, 269 (N.D. Miss. 2018); *Nat'l Women's Political Caucus*, 359 F. Supp. 3d at 18; *IMAPizza*, 334 F. Supp. 3d at 110.

²⁴³³ See *Am. Dairy Queen*, 129 U.S.P.Q.2d at 1293 (Minnesota long-arm statute coextensive with due process); *Sullivan*, 360 F. Supp. 3d at 783 (Illinois long-arm statute coextensive with due process); *Nat'l Women's Political Caucus*, 359 F. Supp. 3d at 18-19 (District of Columbia long-arm statute coextensive with due process); *San Diego Cty. Credit Union*, 325 F. Supp. 3d at 1095 (California long-arm statute coextensive with due process).

²⁴³⁴ *San Diego Cty. Credit Union*, 325 F. Supp. 3d at 1098 (quoting *Schwarzenegger v. Fred Martin Motor Co.*, 374 F.3d 797, 802 (9th Cir. 2004)).

²⁴³⁵ Fed. R. Civ. P. 4(k)(2).

²⁴³⁶ For an example of a case in which a defendant was deemed to have consented to an exercise of personal jurisdiction by virtue of its certificate to do business within the forum state, see *American Dairy Queen Corp.*, 129 U.S.P.Q.2d at 1293.

based entity in the same business helped subject the first company to an exercise of specific personal jurisdiction under California law.²⁴³⁷ The record on the defendant's motion to dismiss established that, after purchasing the three-branch California credit union, the defendant expanded its operations in the state by opening two additional branches and by registering an agent for service of process in California. It then petitioned the Trademark Trial and Appeal Board to cancel a registration owned by the plaintiff based on the defendant's allegations that the registered mark infringed the defendant's rights to a similar mark.

Although declining to accept the plaintiff's argument that the defendant's presence in California rendered an exercise of general personal jurisdiction appropriate, the court found that it enjoyed specific personal jurisdiction over the defendant. With respect to the question of whether the defendant had purposefully directed its activities toward the state of California, the court applied the tripartite "effects test" arising from the Supreme Court's opinion in *Calder v. Jones*,²⁴³⁸ to conclude that: (1) "[the defendant] . . . committed intentional acts by acquiring three branches of [the California credit union], rebranding them . . . , adding two branches in California and marketing its services by using the purported trademarks [upon which it based its cancellation action]";²⁴³⁹ (2) the same considerations and the defendant's petition to cancel the plaintiff's registration meant the defendant had purposefully directed its activities toward California;²⁴⁴⁰ and (3) "the intentional acts of [the defendant] expressly aiming its conduct at California will likely cause harm to [the plaintiff] in California."²⁴⁴¹ The court then concluded that the plaintiff's claims arose out of the defendant's activities in California because "[t]he impetus of [the defendant's] cancellation petition was a result of its expansion of its credit union services from Illinois to northern California."²⁴⁴²

Having resolved those two inquiries in the plaintiff's favor, the court required the defendant to demonstrate that an exercise of jurisdiction would not comport with fair play and substantial justice. Applying a five-part test, it found seriatim that: (1) "litigation will not significantly burden [the defendant] as it conducts business in California and has many employees here";²⁴⁴³ (2) "California has a strong interest in protecting its citizens from trademark infringement and consumer confusion between two entities

²⁴³⁷ See *San Diego Cty. Credit Union*, 325 F. Supp. 3d at 1097-1102.

²⁴³⁸ 465 U.S. 783 (1984).

²⁴³⁹ *San Diego Cty. Credit Union*, 325 F. Supp. 3d at 1099.

²⁴⁴⁰ *Id.* at 1099-1100.

²⁴⁴¹ *Id.* at 1101.

²⁴⁴² *Id.*

²⁴⁴³ *Id.* at 1102.

operating in California”;²⁴⁴⁴ (3) “[the plaintiff] has an interest in obtaining full relief in this Court because relief in the TTAB cancellation proceedings is limited”;²⁴⁴⁵ (4) “California is the most efficient forum for judicial resolution as this case will resolve all issues while the TTAB is limited to deciding matters relating to registration”;²⁴⁴⁶ and (5) “California has a strong interest in furthering substantive social policies as [the defendant] seeks to protect its California operations and consumers from [the plaintiff’s] alleged infringement and [the plaintiff] filed this case to protect itself and its California consumers.”²⁴⁴⁷ The court therefore declined to dismiss the action for want of personal jurisdiction.

The same result transpired in an opinion by a different California federal district court.²⁴⁴⁸ A primary basis of the plaintiff’s claim that the defendant was subject to an exercise of specific personal jurisdiction was the defendant’s operation of an interactive website, of which the plaintiff averred that “through the use of its interactive website, Defendant advertised, displayed, and offered for sale products [under the accused mark] that were similar to Plaintiff’s products to consumers in this district”;²⁴⁴⁹ plus, “Defendant’s website also [allegedly] includes several news articles and promotional advertisements targeted at the [forum district].”²⁴⁵⁰ In any case, however, “personal jurisdiction does not hinge on the sale of the accused products in the forum state; all that a plaintiff needs to show is that the defendant ‘willfully infringed’ and that the defendant knew that the plaintiff had its principal place of business in this district,” both of which were established by the averments in the plaintiff’s complaint.²⁴⁵¹ Having thus concluded that the defendant had purposefully directed its activities toward California, the court next concluded that the defendant’s alleged knowledge of the plaintiff’s domicile in that state satisfied the requirement that the defendant’s conduct cause foreseeable harm there.²⁴⁵² With the defendant failing to put up much of a fight on the issues of whether the plaintiff’s claim arose out of the defendant’s California-related conduct and the constitutional

²⁴⁴⁴ *Id.*

²⁴⁴⁵ *Id.*

²⁴⁴⁶ *Id.*

²⁴⁴⁷ *Id.*

²⁴⁴⁸ *See Int’l Aero Prods., LLC v. Aero Advanced Paint Tech., Inc.*, 325 F. Supp. 3d 1078 (C.D. Cal. 2018).

²⁴⁴⁹ *Id.* at 1085.

²⁴⁵⁰ *Id.*

²⁴⁵¹ *Id.*

²⁴⁵² *Id.*

reasonableness of haling it into a California court, the court denied its motion to dismiss.²⁴⁵³

Alleged online misconduct by a defendant similarly produced an exercise of specific personal jurisdiction by a Virginia federal district court.²⁴⁵⁴ According to the plaintiff, the out-of-state defendant had directed business activity into Virginia not only by changing the phone number listed in the plaintiff's Google listing but also by substituting a new number that, despite having a Virginia area code, diverted callers to a Michigan-based competitor of the plaintiff. Based on those allegations, the court denied the defendant's motion to dismiss, holding that "[the defendant] targeted a Virginia company and attempted to usurp Virginia clients using a phone number with a Virginia area code. For these reasons, the Court can constitutionally exercise personal jurisdiction over [the defendant]."²⁴⁵⁵

In an additional case presenting an unsuccessful motion to dismiss for want of specific personal jurisdiction, the owner of a pizzeria chain based in the District of Columbia haled a group of Scottish domiciliaries into federal district court in that jurisdiction.²⁴⁵⁶ According to the plaintiff, the lead defendant's principals had visited one of the plaintiff's stores, where they masqueraded as customers as part of a scheme to establish copycat restaurants in Scotland. The court concluded that this conduct qualified as "transacting any business in the District of Columbia" for purposes of the local long-arm statute,²⁴⁵⁷ even though the defendants did not operate any restaurants in the District. According to the court, the defendants' travel to the District to research the plaintiff's operations "could be considered an important business activity";²⁴⁵⁸ "[m]oreover," the court found, "there was at least some kind of 'transaction' in the traditional sense, as [one of the defendants] was a customer of [the plaintiff's local restaurant] during his visit."²⁴⁵⁹ Not only did the plaintiff's claims therefore arise from the defendants' conduct within the District and establish purposeful conduct with it,²⁴⁶⁰ that nexus satisfied the constitutional reasonableness of the defendants answering for their conduct in a D.C. court.²⁴⁶¹

²⁴⁵³ *Id.* at 1086.

²⁴⁵⁴ See *BHR Recovery Cmtys., Inc. v. Top Seek, LLC*, 355 F. Supp. 3d 416 (E.D. Va. 2018).

²⁴⁵⁵ *Id.* at 423.

²⁴⁵⁶ See *IMAPizza, LLC v. At Pizza Ltd.*, 334 F. Supp. 3d 95 (D.D.C. 2018).

²⁴⁵⁷ D.C. Code § 13-423(a)(1) (2011).

²⁴⁵⁸ *IMAPizza*, 334 F. Supp. 3d at 112.

²⁴⁵⁹ *Id.*

²⁴⁶⁰ *Id.* at 113-15.

²⁴⁶¹ *Id.* at 115-16.

An application of the same long-arm statute similarly resulted in a Louisville, Kentucky-based political caucus being haled into court in the District to answer to a claim of infringement.²⁴⁶² That defendant once had been a local affiliate of the plaintiff and for decades collected and sent membership dues to the plaintiff in Washington, D.C. That relationship was enough to establish the defendant's purposeful availment of the privilege of doing business in the District:

[The defendant] voluntarily chose to affiliate with [the plaintiff], thereby creating an ongoing relationship between the two entities. The fact [the defendant] was obligated—according to [the plaintiff's] allegations, which the Court must take as true for the purposes of this motion—to remit membership dues to the national organization in D.C., all while abiding by [the plaintiff's] rules, using [the plaintiff's] marks, and encouraging its members to attend and participate in [the plaintiff's] events, suggests [the defendant] “reach[ed] out beyond one state and create[d] continuing relationships and obligations with citizens of another state,” namely D.C. That is a quintessential act of purposeful availment.²⁴⁶³

Moreover, the parties' former relationship was equally sufficient to preclude an exercise of specific personal jurisdiction over the defendant from offending constitutional considerations of fair play and substantial justice, especially because the defendant's alleged violation of the plaintiff's rights—which arose from the defendant's continued use of the plaintiff's marks after its termination as a licensee—was inextricably linked to that relationship.²⁴⁶⁴

Seeking to escape an action filed against him in Illinois, a former member of the band Survivor successfully convinced a court that the plaintiffs' complaint—filed by the band's founding member and a company he controlled—failed to allege that the defendant had used the band's name within the state.²⁴⁶⁵ Although that initial success ordinarily might have led to the dismissal of the case, the complaint did allege that, while an Illinois resident, the defendant had executed an agreement defining the terms of his withdrawal from the band. The court found that “[a]s the contract was negotiated and signed in Illinois, and the parties to the contract were domiciled in the state at the time, it is reasonable to assume that the parties contemplated that performance of the agreement would occur in

²⁴⁶² See *Nat'l Women's Political Caucus, Inc. v. Metro. Louisville Women's Political Caucus, Inc.*, 359 F. Supp. 3d 13 (D.D.C. 2019).

²⁴⁶³ *Id.* at 24 (eighth alteration in original) (citation omitted) (quoting *Travelers Health Ass'n v. Com. of Va. ex rel. State Corp. Comm'n*, 339 U.S. 643, 647 (1950)).

²⁴⁶⁴ *Id.* at 24-25.

²⁴⁶⁵ See *Sullivan v. Bickler*, 360 F. Supp. 3d 778 (N.D. Ill. 2019).

Illinois as well.”²⁴⁶⁶ Moreover, “[the corporate plaintiff], which is still located in Illinois, has consistently worked with [the defendant] or his attorney in order to meet its obligations under the agreement, including sending him paychecks from its Illinois bank account and preparing and issuing tax documents to [the defendant] from Illinois.”²⁴⁶⁷ “Accordingly,” the court held, “both the negotiation of the Withdrawal Agreement and the subsequent dealings between [the parties] indicate that [the defendant] would have expected at some point to be ‘haled into court’ in Illinois if there was a contract dispute.”²⁴⁶⁸

Because the New York long-arm statute is not coextensive with due process,²⁴⁶⁹ establishing the propriety of an exercise of personal jurisdiction under it can be difficult. Nevertheless, one group of plaintiffs successfully did so in an action in which an individual defendant domiciled in Illinois sought to escape a lawsuit in New York for want of personal jurisdiction.²⁴⁷⁰ Based in part on a purchase made by their private investigator, the plaintiffs averred that the individual defendant was personally responsible for shipments by companies he controlled of goods bearing infringing copies of the plaintiffs’ marks into New York. Not only did that alleged conduct satisfy the requirements of the long-arm statute, but it also meant that “[the defendant’s] purposeful availment of the forum state is also closely tied to the claims asserted by the [plaintiffs]: the business transactions conducted by [the defendant] in New York are sales of the allegedly infringing products that form the basis for the [plaintiffs’] claims in this suit.”²⁴⁷¹

Finally, the First Circuit upheld an exercise of specific personal jurisdiction through an application of Rule 4(k)(2), which it held mandated the application of a tripartite test: “Rule 4(k)(2) has three requirements: (1) the cause of action must arise under federal law; (2) the defendant must not be subject to the personal jurisdiction of any state court of general jurisdiction; and (3) the federal court’s exercise of personal jurisdiction must comport with due process.”²⁴⁷² The defendant, a company based in Germany operating an English-language website providing cloud-based services, did not dispute that the first two of these factors favored an exercise of jurisdiction, but it argued that haling it into court in Maine violated its due process rights because it had not purposefully availed itself of the

²⁴⁶⁶ *Id.* at 785.

²⁴⁶⁷ *Id.*

²⁴⁶⁸ *Id.* at 785-86.

²⁴⁶⁹ See *Licci ex rel. Licci v. Lebanese Canadian Bank, SAL*, 732 F.3d 161, 170 (2d Cir. 2013).

²⁴⁷⁰ See *Nat’l Hockey League v. Hockey Cup LLC*, 129 U.S.P.Q.2d 1354 (S.D.N.Y. 2019).

²⁴⁷¹ *Id.* at 1360.

²⁴⁷² *Plixer Int’l, Inc. v. Scrutinizer GmbH*, 905 F.3d 1, 6 (1st Cir. 2018).

privilege of doing business within that state and because an exercise of personal jurisdiction was constitutionally unfair.

As had the district court before it, the First Circuit rejected both of those arguments. With respect to the first, the court noted that the defendant had not done anything to discourage United States consumers from purchasing its services; “[i]n fact,” the court concluded, “the [defendant’s] website gives no indication that it is not meant for U.S. consumption, or even that it is run by a German company.”²⁴⁷³ Moreover, “[the defendant] voluntarily served U.S. customers” over a three-year period, which the court held precluded the defendant from claiming its contact with the United States was involuntary.²⁴⁷⁴ Finally, the court cited the defendant’s “nearly \$200,000 in [U.S.] business over three-and-a-half years” and the filing of an application to register its allegedly infringing mark with the USPTO as additional evidence of purposeful availment.²⁴⁷⁵

Turning to the inquiry into whether an exercise of personal jurisdiction was constitutionally reasonable, the court acknowledged that litigation in the United States would impose a “significant burden” on the defendant, but it accorded that burden reduced weight in light of the defendant’s “substantial and recurrent business in the U.S.”²⁴⁷⁶ It then observed, “the United States has an interest in remedying an alleged injury that occurs in the United States.”²⁴⁷⁷ Under these circumstances, the defendant had failed to demonstrate the unfairness of requiring it to defend itself in a United States: In the final analysis, “[w]hen minimum contacts have been established, often the interests of the plaintiff and the forum in the exercise of jurisdiction will justify even the serious burdens placed on the alien defendant.”²⁴⁷⁸

b. Opinions Declining to Exercise Personal Jurisdiction

The reach of the New York long-arm statute²⁴⁷⁹ is not coextensive with due process, meaning that its requirements must be satisfied before a court reaches the constitutional component of an inquiry into specific personal jurisdiction.²⁴⁸⁰ One plaintiff learned that proposition the hard way in a case in which it sought to hale an individual defendant into a federal district court located

²⁴⁷³ *Id.* at 9.

²⁴⁷⁴ *Id.*

²⁴⁷⁵ *Id.* at 10-11.

²⁴⁷⁶ *Id.* at 12.

²⁴⁷⁷ *Id.*

²⁴⁷⁸ *Id.* at 13 (quoting *Asahi Metal Indus. v. Superior Ct. of Cal.*, 480 U.S. 102, 114 (1987)).

²⁴⁷⁹ N.Y. C.P.L.R. 302 (McKinney 2008).

²⁴⁸⁰ See *Banco Ambrosiano, S.P.A. v. Artoc Bank & Trust Ltd.*, 464 N.E.2d 432, 435 (N.Y. 1984) (“[I]n setting forth certain categories of bases for long-arm jurisdiction, [the New York long-arm statute] does not go as far as is constitutionally permissible.”).

in that state.²⁴⁸¹ The plaintiff's amended complaint averred in conclusory fashion that that defendant—a principal of the lead corporate defendant—had personally participated in the trade dress infringement and related torts covered by the complaint's various causes of action, and the plaintiff argued in response to the defendant's motion to dismiss that the court was obligated to assume the truth of that averment. The court disagreed, pointing out the inapplicability of that rule "since the amended complaint is bereft of any facts tending to support those allegations."²⁴⁸² It next rejected the theory that the lead corporate defendant had acted as the individual defendant's agent for purposes of the statute because "Plaintiff's conclusory allegations in the complaint are insufficient to make a prima facie showing that [the individual defendant] was a primary actor in the specific transactions giving rise to plaintiff's claims in the amended complaint" or that the individual defendant had benefitted from those transactions.²⁴⁸³ In the final analysis, the court held, "[s]ince plaintiff has not made a prima facie showing that [the individual defendant's] own conduct or contacts with the state satisfy New York's long-arm statute, or that the Court's jurisdiction over the [corporate defendants] should be imputed to him under an agency theory," the long-arm statute did not authorize an exercise of personal jurisdiction over him.²⁴⁸⁴

In a second case turning on the requirements of a state long-arm statute,²⁴⁸⁵ a Mississippi federal district court declined to find that the Texas-based defendants' alleged conduct fell within the scope of that state's statute.²⁴⁸⁶ Much of that conduct centered on the defendants' request for a license to use a camouflage pattern in which the plaintiff claimed trade dress rights. According to the plaintiff, the defendants abruptly terminated negotiations between the parties, after which they introduced their own confusingly similar pattern on apparel sold in direct competition with apparel sold by the plaintiff. In addition, the plaintiff averred, the defendants had then sold their offending goods in Mississippi.

The court rejected the plaintiff's argument that those facts satisfied the requirements of the long-arm statute. Although the parties' negotiations took place over a four-month period, "[t]he Defendants' unconsummated negotiations to secure a license, however, do not constitute 'doing business' . . . in the state."²⁴⁸⁷ Moreover, "[t]hat [the plaintiff] resides in Mississippi does not

²⁴⁸¹ See *Wolo Mfg. Corp. v. ABC Corp.*, 349 F. Supp. 3d 176 (E.D.N.Y. 2018).

²⁴⁸² *Id.* at 196.

²⁴⁸³ *Id.* at 199.

²⁴⁸⁴ *Id.*

²⁴⁸⁵ See *Haas Outdoors, Inc. v. Dryshod Int'l, LLC*, 347 F. Supp. 3d 266 (N.D. Miss. 2018).

²⁴⁸⁶ Miss. Code Ann. § 13-3-57 (2019).

²⁴⁸⁷ *Id.* at 270.

necessarily mean the injury occurred in Mississippi, because the actual injury must be distinguished from ‘its resultant consequences’²⁴⁸⁸ On that issue, the court held that “the tort occurs where infringing sales are made, not simply where the mark owner resides” and that any sales in Mississippi had been made by one of the defendants’ distributors, rather than the defendants themselves.²⁴⁸⁹ Finally, it found, “[t]he only retail purchase of the offending goods was made by [the plaintiff’s] employees,”²⁴⁹⁰ which meant “[i]t cannot be said that [the plaintiff] was ‘confused as to the source of the products in question.’”²⁴⁹¹ Because the state long-arm statute did not extend to the limits of due process, the failure of the plaintiff’s averments to satisfy its requirements obviated the need to proceed with a constitutional analysis.²⁴⁹²

5. Venue

Under 28 U.S.C. § 1391(b), venue in a federal court action will properly lie in a district in which “any defendant resides, if all defendants are residents of the State in which the district is located,” “in which a substantial part of the events or omissions giving rise to the claim occurred,” or in which any defendant may be found “if there is no district in which an action may otherwise be brought.”²⁴⁹³ A challenge to the venue chosen by a plaintiff can take the form of a motion to dismiss brought under Federal Rule of Civil Procedure 12(b)(3) and 28 U.S.C. § 1406(a), the latter of which authorizes federal district courts to transfer or dismiss cases “laying venue in the wrong division or district,”²⁴⁹⁴ and which is arguably a codification of the common-law doctrine of *forum non conveniens*.²⁴⁹⁵ A venue challenge can also include a motion to transfer under 28 U.S.C. § 1404(a), which provides, “[f]or the convenience of [the] parties and the witnesses, in the interest of justice, a district court may transfer any civil action to any other district or division where it might have been brought”²⁴⁹⁶ Finally, under Federal Rule of Civil Procedure 45(f), a showing of “exceptional circumstances” can

²⁴⁸⁸ *Id.* (quoting *Allred v. Moore & Peterson*, 117 F.3d 278, 281 (5th Cir. 1997)).

²⁴⁸⁹ *Id.*

²⁴⁹⁰ *Id.*

²⁴⁹¹ *Id.* (quoting *721 Bourbon, Inc. v. House of Auth, LLC*, 140 F. Supp. 3d 586, 596 (E.D. La. 2015)).

²⁴⁹² *Id.* at 272.

²⁴⁹³ 28 U.S.C. § 1391(b) (2018).

²⁴⁹⁴ *Id.* § 1406(a).

²⁴⁹⁵ See generally *Sinochem Int’l Co. v. Malaysia Int’l Shipping Corp.*, 549 U.S. 422, 423 (2007) (noting that dismissal or transfer appropriate under *forum non conveniens* “when considerations of convenience, fairness, and judicial economy so warrant”).

²⁴⁹⁶ 28 U.S.C. § 1404(a) (2018).

justify the transfer of subpoena-related motions to the court of issuance.²⁴⁹⁷

a. Opinions Finding Venue Proper

In the event of competing lawsuits by the same parties, the “first-to-file” rule generally provides that the court hearing the first action will enjoy jurisdiction over both parties’ claims, with the usual result that the second-filed suit will either be dismissed or transferred.²⁴⁹⁸ An unusual—and predictably unsuccessful—invocation of the rule occurred in a dispute in which the plaintiff filed an action in the Central District of California, in response to which the defendant filed its own action in the Southern District of Ohio, after which the plaintiff served an amended complaint that differed from the original only in that it corrected an inaccurate description of the defendant’s domicile.²⁴⁹⁹ Rather improbably, the defendant asserted its action as the prior-filed one, and it sought a transfer to the Southern District of Ohio as a result. The court was in no mood to entertain that theory: On the contrary, it (properly) held that “[t]he first-filed rule is triggered upon the filing of a complaint, regardless of whether a plaintiff later amends the complaint.”²⁵⁰⁰ Because “[i]t is abundantly clear that Plaintiff’s action in this district was filed first,” the defendant’s motion for a transfer of the action was meritless.²⁵⁰¹

A more conventional application of the first-to-file rule came in a dispute in which the plaintiff filed an action in the District of Minnesota, after which the defendant initiated its own lawsuit in the District of Massachusetts.²⁵⁰² The defendant then moved the Minnesota court to transfer the proceedings before it to Massachusetts, but, in the estimation of the Minnesota court, it failed to identify “any compelling circumstances” warranting that disposition. In particular, it found, “[the defendant] has not sufficiently argued that [the plaintiff] acted in bad faith, that [the plaintiff] raced to the courthouse as a result of learning [the defendant] was going to file, or that [the plaintiff] sought a declaratory judgment against [the defendant].”²⁵⁰³ Worse still, “[the

²⁴⁹⁷ Fed. R. Civ. P. 45(f).

²⁴⁹⁸ See generally *Cordell Eng’g, Inc. v. Picker Int’l, Inc.*, 540 F. Supp. 1316, 1318 (D. Mass. 1982) (“[W]here two suits involve the same issues, and prosecution of both would entail duplicative litigation and a waste of judicial resources, the first filed suit is generally preferred.”).

²⁴⁹⁹ See *Int’l Aero Prods., LLC v. Aero Advanced Paint Tech., Inc.*, 325 F. Supp. 3d 1078 (C.D. Cal. 2018).

²⁵⁰⁰ *Id.* at 1087.

²⁵⁰¹ *Id.*

²⁵⁰² See *Am. Dairy Queen Corp. v. W.B. Mason Co.*, 129 U.S.P.Q.2d 1291 (D. Minn. 2019).

²⁵⁰³ *Id.* at 1297.

defendant] has not adequately stated that it is more convenient for the parties or witnesses to litigate in Massachusetts or that the interests of justice would be served in doing so.”²⁵⁰⁴ The litigation therefore remained lodged in Minnesota.

A New York federal district court similarly rejected an attempt by a pair of defendants to divest it of an infringement and unfair competition action, albeit in a case not featuring a competing lawsuit elsewhere.²⁵⁰⁵ On one level, the defendants argued venue was improper, but the court disposed of that theory by finding that a substantial part of the events giving rise to the action had occurred in the forum district. It reached that finding based on the plaintiffs’ averment that the defendants had shipped products into the district²⁵⁰⁶ and that consumers within it could make purchases on the defendants’ website. Equally to the point, “[t]he [plaintiffs] [are] headquartered in the district and any injuries resulting from the alleged violation of the [plaintiffs’] intellectual property rights thus would have occurred, at least in part, in this district.”²⁵⁰⁷ The plaintiffs therefore had made out a prima facie case that venue was proper.

The court then addressed—and similarly rejected—the defendants’ backup argument that they were entitled to a transfer of the action to the Northern District of Illinois under 28 U.S.C. § 1404(a). The defendants’ argument on that issue was hindered by the court’s initial holding that “[g]enerally speaking, there is ‘a strong presumption in favor of the plaintiff’s choice of forum,’ and, indeed, ‘unless the balance is strongly in favor of the defendant, the plaintiff’s choice of forum should rarely be disturbed.’”²⁵⁰⁸ The court then identified the private-interest and public-interest factors properly governing the inquiry whether a transfer was appropriate:

Factors relating to the parties’ private interests include relative ease of access to sources of proof; availability of compulsory process for attendance of unwilling, and the cost of obtaining attendance of willing, witnesses; possibility of view of premises, if view would be appropriate to the action; and all other practical problems that make trial of a case easy, expeditious and inexpensive. Public-interest factors may include the administrative difficulties flowing from court congestion; the local interest in having localized controversies decided at home; [and] the interest in having

²⁵⁰⁴ *Id.*

²⁵⁰⁵ *See Nat’l Hockey League v. Hockey Cup LLC*, 129 U.S.P.Q.2d 1354 (S.D.N.Y. 2019).

²⁵⁰⁶ On this issue, the court noted that “[t]he fact that these allegedly infringing items were purchased by an investigator employed by the [plaintiffs’] law firm does not make venue improper.” *Id.* at 1358.

²⁵⁰⁷ *Id.*

²⁵⁰⁸ *Id.* (quoting *Norex Petroleum Ltd. v. Access Indus.*, 416 F.3d 146, 154 (2d Cir. 2005)).

the trial of a diversity case in a forum that is at home with the law. The Court must also give some weight to the plaintiffs' choice of forum.²⁵⁰⁹

The defendants fared poorly in an application of those factors. Not only did the plaintiffs' choice of forum deserve "significant weight," there was no evidence that their decision to file suit in their home forum "was made for any wrongful tactical purpose."²⁵¹⁰ So too did the defendants fail to demonstrate that the balance of the parties' convenience favored a transfer in light of their inability to identify more than one non-party potential witness located in the proposed transferee forum. Finally, the defendants' motion fell short under the public-interest factors as well because "[s]everal of the [plaintiffs'] claims arise under New York law, a body of law with which this district is likely more familiar than is the Northern District of Illinois."²⁵¹¹ The case therefore remained in the Southern District of New York.

The deference accorded a plaintiff's choice of forum helped lead to the denial of an additional motion to transfer under Section 1404(a).²⁵¹² The plaintiff chose to file the action in its home forum of the District of Minnesota, while the defendant sought a transfer to the Eastern District of Michigan. Seeking to establish that the convenience of the parties themselves favored relocation of the case, the defendant argued it was a much smaller company than the plaintiff, but the court found the defendant's prospective inconvenience of litigating in Minnesota "only slighter than the inconvenience to the plaintiff of litigating in Michigan."²⁵¹³ The court also rejected the defendant's argument that the convenience of potential witnesses favored a transfer, concluding instead that the location of party witnesses deserved little weight and that neither the plaintiff nor the defendant had adequately explained the potential significance of its proffered non-party witnesses.²⁵¹⁴ The defendant's reliance on the interests of justice similarly failed to get the job done because, although one dispute in the case presented a question of Michigan contract law, that question was not complicated or nor novel and because "only a minor difference exists in the average lengths of time from filing to disposition" within the two districts in question.²⁵¹⁵ Finally, although not dispositive, the plaintiff's choice of forum weighed against the requested transfer,

²⁵⁰⁹ *Id.* (alteration in original) (quoting *Atl. Marine Constr. Co. v. U.S. Dist. Court for W. Dist. of Texas*, 571 U.S. 49, 62 n.6 (2013)).

²⁵¹⁰ *Id.*

²⁵¹¹ *Id.* at 1359.

²⁵¹² *See My Pillow, Inc. v. LMP Worldwide, Inc.*, 331 F. Supp. 3d 920 (D. Minn. 2018).

²⁵¹³ *Id.* at 928.

²⁵¹⁴ *Id.*

²⁵¹⁵ *Id.*

“particularly when the plaintiff resides in the district in which the lawsuit was filed.”²⁵¹⁶

In a last reported opinion denying a motion to dismiss or, in the alternative, for a transfer to the Western District of Kentucky, a District of Columbia federal district court went even further in identifying the plaintiff’s choice of forum as the “paramount consideration” under Section 1404(a).²⁵¹⁷ In doing so, the court rejected the defendant’s argument that the balance of the conveniences “strongly” favored a transfer, finding instead that “[i]t is likely the case will involve witnesses located in D.C., Kentucky, and elsewhere around the country; neither forum would eliminate the need for at least some witnesses to travel.”²⁵¹⁸ Moreover, “[w]hile it would be more convenient for [the defendant] to litigate in Kentucky, where all its board members reside, transfer for this reason would simply ‘shift inconvenience to the plaintiffs’ rather than ‘lead to an overall increase in convenience for the parties.’”²⁵¹⁹ So too, the court found, “the ease of access to sources of proof, is also a wash; [the defendant] admits that the main sources of proof will consist of ‘documentary evidence that can be readily exchanged electronically,’ and so this factor favors neither venue.”²⁵²⁰ Not only was there consequently no reason to disregard the plaintiff’s choice of forum, the defendant also failed to demonstrate “how Kentucky’s interest in the parties’ trademark infringement and unfair competition dispute is any stronger than D.C.’s.”²⁵²¹ The court therefore rejected the defendant’s bid for a transfer.

b. Opinions Declining to Find Venue Proper

When a Mississippi-based plaintiff sued a Texas-based group of defendants, the defendants successfully established to the satisfaction of the federal district court hearing the matter that an exercise of personal jurisdiction over them would violate the requirements of the state long-arm statute.²⁵²² Rather than dismissing the matter, however, the court exercised the discretion accorded to it under the Federal Rules of Civil Procedure²⁵²³ and

²⁵¹⁶ *Id.* at 930.

²⁵¹⁷ Nat’l Women’s Political Caucus, Inc. v. Metro. Louisville Women’s Political Caucus, Inc., 359 F. Supp. 3d 13, 26 (D.D.C. 2019) (quoting *Air Line Pilots Ass’n v. E. Air Lines*, 672 F. Supp. 525, 526 (D.D.C. 1987)).

²⁵¹⁸ *Id.* at 26.

²⁵¹⁹ *Id.* (quoting *United States ex rel. Westrick v. Second Chance Body Armor, Inc.*, 771 F. Supp. 2d 42, 48 (D.D.C. 2011)).

²⁵²⁰ *Id.*

²⁵²¹ *Id.*

²⁵²² *See Haas Outdoors, Inc. v. Dryshod Int’l, LLC*, 347 F. Supp. 3d 266, 270 (N.D. Miss. 2018).

²⁵²³ *See Fed. Rule Civ. P. 12(b)(2).*

federal statutory law²⁵²⁴ and to transfer the matter from the Northern District of Mississippi to the Western District of Texas. The court identified several reasons for taking that step. To begin with, it noted, the defendants resided in the transferee district and both personal jurisdiction and venue would properly lie there. In addition, the plaintiff had originally filed its action in that district before dismissing it and refiled in the Northern District of Mississippi; the doctrinal significance of that consideration went unexplained.²⁵²⁵

In a rare disposition, a different court responded to a motion to quash a subpoena duces tecum by transferring the matter to the court issuing the subpoena under Rule 45(f).²⁵²⁶ The subpoena in question targeted records by outside intellectual property counsel for the defendant in the underlying litigation and arose from the plaintiffs' concern that they would not receive the responsive documents from the defendants themselves via the plaintiffs' discovery requests. Rather than evaluate the plaintiff's entitlement to the documents in question itself, the court instead referred that question to the originating court, finding in the process that:

[E]xceptional circumstances exist for two reasons. First, the [plaintiffs in the underlying action] only seek this information from the [law firm and its attorneys] because they are concerned that they cannot get it from [the defendant in the underlying action]. The propriety of these third-party subpoenas necessarily turns on what [the plaintiffs] can obtain from [the defendant], and *that* issue is already before the originating court. Second, even the issue of attorney-client privilege raised in the [law firm's] Motion to Quash rests on factual and legal developments that the underlying court will be in a better position to manage.²⁵²⁷

The court therefore sua sponte ordered the matter transferred to the originating court.

6. Issue and Claim Preclusion

a. Issue Preclusion (Collateral Estoppel)

In *B & B Hardware, Inc. v. Hargis Indus.*,²⁵²⁸ the Supreme Court offered the following explanation of the doctrine of issue preclusion:

Sometimes two different tribunals are asked to decide the same issue. When that happens, the decision of the first

²⁵²⁴ See 28 U.S.C. § 1406(a) (2018).

²⁵²⁵ *Haas Outdoors*, 347 F. Supp. 3d at 273.

²⁵²⁶ See *In re Nonparty Subpoenas Duces Tecum*, 327 F.R.D. 23 (D.D.C. 2018).

²⁵²⁷ *Id.* at 23-24 (citation omitted).

²⁵²⁸ 575 U.S. 138 (2015) ("*B&B Hardware I*").

tribunal usually must be followed by the second, at least if the issue is really the same. Allowing the same issue to be decided more than once wastes litigants' resources and adjudicators' time, and it encourages parties who lose before one tribunal to shop around for another. The doctrine of collateral estoppel or issue preclusion is designed to prevent this from occurring.²⁵²⁹

The Court's opinion did not end the dispute between the parties to that litigation, however, and, indeed, their continued litigation produced a new opinion from the Eighth Circuit over the past year, one that again addressed the metes and bounds of issue preclusion.²⁵³⁰ In a previous battle in the parties' war, a jury found that the plaintiff's registered mark was merely descriptive and lacked acquired distinctiveness. That did not discourage the plaintiff from filing a declaration of incontestability for its registration, and, when the plaintiff initiated a new lawsuit against the defendant, the filing of the declaration constituted a factual change that prevented the plaintiff's earlier loss from having issue-preclusive effect.

In the second trial, however, a different jury found that the plaintiff's Section 15 declaration was fraudulent, thereby giving the plaintiff's registration the same evidentiary value as it had had in the earlier suit. That circumstance, the Eighth Circuit held, barred the second suit under its test for issue preclusion.²⁵³¹ As it explained in affirming the district court's conclusion to identical effect:

[O]ther than incontestability and the passage of time, [the plaintiff] has failed to allege any intervening factual change that would allow it to escape the application of collateral estoppel. Absent any evidence that [its] mark has developed secondary meaning since the [earlier] trial, we decline to allow [the plaintiff] to relitigate that issue.²⁵³²

²⁵²⁹ *Id.* at 140.

²⁵³⁰ *See* B&B Hardware, Inc. v. Hargis Indus., 912 F.3d 445 (8th Cir. 2018) ("*B&B Hardware II*"), *cert. denied*, 140 S. Ct. 218 (2019).

²⁵³¹ That test required showings by the party invoking the doctrine that:

(1) the party sought to be precluded in the second suit was a party . . . in the prior suit; (2) the issue sought to be precluded is the same as the issue involved in the prior action; (3) the issue was actually litigated in the prior action; (4) the issue was determined by a valid and final judgment; and (5) the determination in the prior action was essential to the judgment.

Id. at 452 (alterations in original) (quoting *Morse v. Comm'r of Internal Revenue Serv.*, 419 F.3d 829, 834 (8th Cir. 2005)).

²⁵³² *Id.* at 454.

b. Claim Preclusion (Res Judicata)

Under the doctrine of claim preclusion, or *res judicata*, “a final judgment on the merits of an action precludes the parties or their privies from relitigating issues that were or could have been raised in that action.”²⁵³³ Having explored the parameters of the separate doctrine of issue preclusion in *B & B Hardware*, the Supreme Court turned to claim preclusion by agreeing to review the outcome of an appeal to the Second Circuit.²⁵³⁴ The lower court’s opinion was the latest development in a series of adversarial proceedings, the first round of which the parties resolved through a settlement agreement containing mutual releases and the parties’ consent to the entry of a consent judgment. When the plaintiff uncovered evidence that the defendants had violated the agreement, it filed suit for a second time in 2005, leading the defendants to argue in a motion to dismiss that the mutual releases in the settlement agreement barred the new suit. After the district court denied that motion, the defendants asserted claim preclusion as an affirmative defense in their answer, but otherwise did not raise the issue again. The 2005 action produced a jury verdict in the plaintiff’s favor and a new injunction against the defendants.

In 2011, the plaintiff again filed suit, and the defendants successfully moved the district court for summary judgment based on the plaintiff’s earlier release of them from liability, only to have the Second Circuit reverse that disposition: According to the appellate court, the release did not apply to alleged misconduct occurring after the earlier judgment.²⁵³⁵ On remand, the plaintiff amended its complaint, which the district court dismissed for failure to state a claim after concluding that the plaintiff’s amended claims related only to conduct predating the plaintiff’s execution of the release. In the process, the district court held claim preclusion inapplicable to defenses such as the one asserted by the defendants.

The Second Circuit reversed once again, observing as an initial matter that “[f]or the past quarter of a century, we have assumed that claim preclusion may bar a litigation defense but we have not had a case in which we have found a defense to be so precluded.”²⁵³⁶ The proceeding before it proved to be just such a case under the court’s newly adopted four-part test for claim preclusion:

[D]efense preclusion bars a party from raising a defense where: (i) a previous action involved an adjudication on the merits; (ii) the previous action involved the same parties or

²⁵³³ *Allen v. McCurry*, 449 U.S. 90, 94 (1980).

²⁵³⁴ *See Marcel Fashions Grp. v. Lucky Brand Dungarees, Inc.*, 898 F.3d 232 (2d Cir. 2018) (“*Marcel II*”), *cert. granted*, 139 S. Ct. 2777 (2019).

²⁵³⁵ *See Marcel Fashions Grp. v. Lucky Brand Dungarees, Inc.*, 779 F.3d 102, 108 (2d Cir. 2015) (“*Marcel I*”).

²⁵³⁶ *Id.* at 237.

those in privity with them; (iii) the defense was either asserted or could have been asserted, in the prior action; and (iv) the district court, in its discretion, concludes that preclusion of the defense is appropriate because efficiency concerns outweigh any unfairness to the party whose defense would be precluded.²⁵³⁷

Deeming these requirements “easily met,”²⁵³⁸ the court summarily disposed of the defendants’ attempted reliance on the inconsistency of the court allowing the plaintiff to assert new claims while not allowing the defendant the opportunity to assert a new defense in response to those claims. As it explained in a footnote, though our rulings, when read together, mean that [the plaintiff’s] claims are not barred by *res judicata* but that one of [the defendants’] defenses to those claims is so precluded, there is no unfairness in that. Both are traditional applications of claim preclusion principles.”²⁵³⁹ Undoubtedly because of the patent inconsistency of that outcome with holdings to opposite effect from the Ninth Circuit,²⁵⁴⁰ the Eleventh Circuit²⁵⁴¹ and the Federal Circuit,²⁵⁴² the Supreme Court granted the defendants’ petition for a writ of certiorari, which presented the following question: “Whether, when a plaintiff asserts new claims, federal preclusion principles can bar a defendant from raising defenses that were not actually litigated and resolved in any prior case between the parties.”²⁵⁴³

In a less momentous dispute producing a holding of claim preclusion, the plaintiff had previously asserted a claim of reverse passing off against a privy of one of the defendants.²⁵⁴⁴ The earlier action was resolved through a stipulated dismissal disposing of “all claims and causes of action arising in the above-styled action,”²⁵⁴⁵ and that resolution led to a holding of claim preclusion in the later case because each of the three requirements for that doctrine under Third Circuit law was present, namely: “(1) a final judgment on the

²⁵³⁷ *Id.* at 241.

²⁵³⁸ *Id.*

²⁵³⁹ *Id.* at 242 n.10.

²⁵⁴⁰ *See Orff v. United States*, 358 F.3d 1137, 1141 (9th Cir. 2004) (holding defensive claim preclusion inapplicable in subsequent case asserting claims post-dating resolution of earlier case), *aff’d on other grounds*, 545 U.S. 596 (2005).

²⁵⁴¹ *See McKinnon v. Blue Cross & Blue Shield of Ala.*, 935 F.2d 1187, 1192 (11th Cir. 1991) (“For *res judicata* to apply [to a defense], the same cause of action must be involved in both cases (i.e., the cases must be based upon the same factual predicate).”).

²⁵⁴² *See Nasalok Coating Corp. v. Nylok Corp.*, 522 F.3d 1320, 1327 (Fed. Cir. 2008) (holding that “the plaintiff and defendant” are “treated equally” when it comes “to *res judicata*”).

²⁵⁴³ *Petition for Writ of Certiorari at *i, Lucky Brand Dungarees, Inc. v. Marcel Fashions Grp.*, 139 S. Ct. 2777 (2019) (No. 18–1086).

²⁵⁴⁴ *See Ecore Int’l, Inc. v. Downey*, 343 F. Supp. 3d 459 (E.D. Pa. 2018).

²⁵⁴⁵ *Id.* at 508.

merits in a prior suit involving (2) the same parties or their privies and (3) a subsequent suit based on the same cause of action.”²⁵⁴⁶ This was especially true in light of the plaintiff’s awareness of the role of defendant’s privity in the alleged reverse passing off prior to dismissing its claims against the privity. The defendant therefore was entitled to summary judgment with respect to that cause of action.

In contrast, an assertion of claim preclusion fell short in litigation between a national farmers’ association, on the one hand, and a disaffiliated chapter and its leadership, on the other.²⁵⁴⁷ Earlier litigation between the parties had resulted in a finding of liability for infringement and unfair competition based on the defendants’ continued use of the plaintiffs’ marks. The defendants asserted that that outcome precluded the plaintiffs’ filing of a subsequent suit, but the court held otherwise on the plaintiffs’ motion for summary judgment:

The conduct alleged to support plaintiff’s Lanham Act [and California false advertisement] claims in this action is different from the conduct enjoined in [the earlier litigation]. It involves more than merely the use of the [disputed mark]. To the extent that the complaint here alleges that defendants are representing they are the same organization as the [plaintiffs], that they are responsible for the history and achievements of the [plaintiffs], or making other false or misleading representations causing confusion among local [affiliates of the plaintiffs], it goes beyond the complaint in [the earlier litigation] and seeks to enjoin different conduct.²⁵⁴⁸

Litigation between hospital bed manufacturers, on the one hand, and a medical supply company, on the other, similarly resulted in a summary judgment opinion rejecting the defendants’ assertion of claim preclusion, at least in part.²⁵⁴⁹ In earlier litigation, the plaintiff had accused the defendants of various torts before the parties settled. Although the court held some of the plaintiffs’ allegations in the second suit barred by claim preclusion, that conclusion did not apply to the plaintiffs’ challenge to advertising undertaken by the defendants after the earlier litigation. That advertising, the court held, prevented the defendants from satisfying the third requirement of the court’s three-part test for claim preclusion: (1) an identity of parties; (2) a final judgment on

²⁵⁴⁶ *Id.* (quoting *Davis v. Wells Fargo*, 824 F.3d 333, 341 (3d Cir. 2016)).

²⁵⁴⁷ See *Nat’l Grange of the Order of Patrons of Husbandry v. California Guild*, 334 F. Supp. 3d 1057 (E.D. Cal.), *reconsideration denied sub nom.* *Nat’l Grange v. California Guild*, No. 2:16-cv-0201 WBS DB, 2018 WL 5270563 (E.D. Cal. Oct. 22, 2018), *appeal docketed*, No. 18-16671 (9th Cir. Sept. 5, 2018).

²⁵⁴⁸ *Id.* at 1064.

²⁵⁴⁹ See *VitalGo, Inc. v. Kreg Therapeutics, Inc.*, 370 F. Supp. 3d 873 (N.D. Ill. 2019).

the merits; and (3) an identity of the causes asserted in the two actions.²⁵⁵⁰

c. Judicial Estoppel

Judicial estoppel precludes a party from abandoning positions after it has prevailed on them in earlier litigation.²⁵⁵¹ In the only reported trademark or unfair competition opinion to address a claim of judicial estoppel over the past year, the court adopted a tripartite test for the doctrine's applicability:

Three factors that inform the decision about whether to apply judicial estoppel are (1) whether the later position is clearly inconsistent with the earlier position; (2) whether the party to be estopped succeeded in persuading the first court to accept its earlier position, "so that judicial acceptance of an inconsistent position in a later proceeding would create the perception that either the first or second court was misled;" and (3) whether the party seeking to assert an inconsistent position would derive an unfair advantage or impose an unfair detriment on the opposing party if not estopped.²⁵⁵²

In an application of that test on a motion to dismiss, the court found the first of these prerequisites was not satisfied. In a prior proceeding between the parties, the plaintiffs had sought to escape liability for breach of contract by assuring the court (and the defendants) that they did not object to the sale of certain goods in the defendants' possession. As the court found, however, the plaintiffs' complaint in the second action did not challenge the defendants' sale of the goods but instead accused the defendants of having infringed the plaintiffs' mark while advertising the goods. The lack of inconsistent positions taken by the plaintiffs therefore disposed of the defendants' claim of judicial estoppel.²⁵⁵³

7. Indispensable Parties

In cases in which a licensee asserts rights to a mark and the defendant counterclaims for the mark's invalidation, courts typically hold that the mark's licensor is an indispensable party to

²⁵⁵⁰ *Id.* at 882.

²⁵⁵¹ *See generally* *Zedner v. United States*, 547 U.S. 489, 504 (2006).

²⁵⁵² *VitalGo, Inc. v. Kreg Therapeutics, Inc.*, 370 F. Supp. 3d 873, 886 (N.D. Ill. 2019) (quoting *In re Knight-Celotex, LLC*, 695 F.3d 714, 721 (7th Cir. 2012)).

²⁵⁵³ *Id.* at 866.

the litigation.²⁵⁵⁴ One court explained the policy considerations underlying that rule in the following manner:

This principle protects (i) absent trademark owners from the estoppel effect of a judgment in which the trademark owner did not participate and which determined the trademark to be invalid, (ii) the plaintiff's interest in avoiding multiple lawsuits concerning the same basic facts and (iii) the public's interest in efficiently utilizing judicial resources.²⁵⁵⁵

Nevertheless, the same court declined to grant a motion to dismiss filed by a group of defendants accused of infringing the plaintiffs' mark simply because, although having named the owner of the allegedly infringing mark as an additional defendant and challenging the validity of his registration, the plaintiffs had not yet served him with the complaint. That outcome held because, in contrast to the usual scenario in which the issue of an indispensable party is raised, "[h]ere, . . . Defendants argue for joinder of another defendant, not a licensor-plaintiff, which eliminates the risk that Defendants will be subject to double, multiple or inconsistent obligations. As a result, this case is better 'analogized to other tort actions' where 'all infringers are jointly and severally liable.'"²⁵⁵⁶ Although thus denying the motion to dismiss, the court noted the defendants could renew it if the plaintiffs proved unable to serve the absent defendant with process.²⁵⁵⁷

8. Extraterritorial Applications of the Lanham Act

An operator of a chain of pizzerias proceeding in the District of Columbia successfully convinced the federal court hearing its case to exercise specific personal jurisdiction over United Kingdom-based defendants the plaintiff accused of infringing its mark, but, despite winning that battle, it ultimately lost the war.²⁵⁵⁸ The fatal flaw in the plaintiff's complaint was an absence of any allegations that the defendants' infringement took place in any way in the United States; instead, the complained-of conduct took place at a single restaurant in Edinburgh, Scotland. Lacking controlling authority on the issue, the court declined to adopt any of the out-of-circuit tests proffered by the parties, holding instead that "[the plaintiff's] claims

²⁵⁵⁴ See, e.g., *May Apparel Grp. v. Ava Imp.-Exp., Inc.*, 902 F. Supp. 93, 96 (M.D.N.C. 1995) ("[T]he owner of a trademark is an indispensable party to any action to cancel the trademark.").

²⁵⁵⁵ *WM Int'l, Inc. v. 99 Ranch Mkt. #601*, 329 F.R.D. 491, 497 (E.D.N.Y. 2019).

²⁵⁵⁶ *Id.*

²⁵⁵⁷ *Id.* at 498.

²⁵⁵⁸ See *IMAPizza, LLC v. At Pizza Ltd.*, 334 F. Supp. 3d 95 (D.D.C. 2018).

are obviously deficient under any test.”²⁵⁵⁹ As the court summarized the averments underlying the plaintiff’s claims of infringement:

[Defendants’] business . . . operates solely in Scotland. As a single pizza restaurant, it is a quintessentially local business. Unsurprisingly, then, there is no allegation that Defendants have made any purchases of supplies or sales of pizza in the United States, or even that their products or advertisements have entered the United States through the stream of commerce. Thus, it does not matter whether one requires a “substantial” effect, “significant” effect, or “some” effect on U.S. commerce. In this case, there is no plausible effect.²⁵⁶⁰

Although the plaintiff strained mightily to “conjure up an effect on U.S. commerce” by invoking the many “25-34 year olds” visiting Edinburgh each year from the United States, the court rejected that theory because “[i]f that were enough to state a claim, then the Lanham Act would extend to all commercial conduct occurring anywhere in the world that American tourists visit in significant numbers.”²⁵⁶¹ The defendants’ motion to dismiss therefore carried the day.²⁵⁶²

9. Sanctions

As usual, motions for sanctions in trademark cases typically fell short. That was the result in an appeal to the Ninth Circuit in which the district court had dismissed the plaintiff’s case with prejudice after offering the plaintiff the opportunity to amend its complaint before a particular date.²⁵⁶³ The Ninth Circuit acknowledged that the Federal Rule of Civil Procedure invoked by the district court—Rule 41(b)—authorized the dismissal of actions for failure to comply with court-ordered deadlines. Nevertheless, it held the rule inapplicable because the district court’s deadline had been permissive, rather than mandatory: “The district court’s dismissal under Rule 41(b) required noncompliance with a court order. A grant of leave to amend is not an order to amend. Therefore, Rule 41(b) did not apply here, and the district court’s dismissal on this ground constituted an abuse of discretion.”²⁵⁶⁴

Two opinions addressed motions for sanctions brought under 28 U.S.C. § 1927, which allows an aggrieved litigant to pursue sanctions against its opposing counsel if that counsel multiplies “the

²⁵⁵⁹ *Id.* at 122.

²⁵⁶⁰ *Id.* at 122 (citations omitted).

²⁵⁶¹ *Id.* at 123.

²⁵⁶² *Id.* at 124.

²⁵⁶³ *See Applied Underwriters, Inc. v. Lichtenegger*, 913 F.3d 884 (9th Cir. 2019).

²⁵⁶⁴ *Id.* at 892.

proceedings . . . unreasonably and vexatiously.”²⁵⁶⁵ “In order for § 1927 to be applicable,” however, “there must be a causal connection between the objectionable conduct of counsel and multiplication of the proceedings. Under the plain statutory language, objectionable conduct—even ‘unreasonable and vexatious’ conduct—is not sanctionable unless it results in proceedings that would not have been conducted otherwise.”²⁵⁶⁶ As the Supreme Court has held, “pretty much by definition, . . . the court can shift only those attorney’s fees incurred because of the misconduct at issue.”²⁵⁶⁷

This requirement of but-for materiality tripped up a group of defendants pursuing sanctions under Section 1927 before a Georgia federal district court.²⁵⁶⁸ The defendants unsuccessfully had sought the dismissal of the plaintiff’s complaint for failure to state a claim, after which they unsuccessfully sought reconsideration of the order denying their motion to dismiss. According to the defendants’ motion for sanctions, counsel for the plaintiff had defeated the motion for reconsideration through a deliberate misrepresentation of fact and thereby unreasonably and vexatiously multiplied the proceeding. In fact, however, the court had denied the motion for reconsideration because of the defendants’ failure to comply with the local rule governing such motions, and it had held a hearing on the defendants’ motion at the *defendants’* and not the *plaintiff’s* request. Because these considerations precluded the showing of materiality necessary under Section 1927, the defendants’ invocation of that section was misplaced and their motion for sanctions without merit.²⁵⁶⁹

Another motion for sanctions under Section 1927 fell short before a different court but for a different reason.²⁵⁷⁰ The occasion of its filing was the plaintiff’s successful challenge at the pleadings stage to two counterclaims for the cancellation of three registrations owned by the plaintiff. One counterclaim asserted all three registrations had been fraudulently procured, while the other rested on the theory that the intent-to-use application maturing into one of the registrations had been unlawfully assigned. Despite the fatal infirmity of each counterclaim, the court disagreed with the plaintiff’s claim that the defendants’ counsel had vexatiously multiplied the pleadings in the case. Instead, it held, “although [the

²⁵⁶⁵ 28 U.S.C. § 1927 (2018).

²⁵⁶⁶ *Peterson v. BMI Refractories*, 124 F.3d 1386, 1396 (11th Cir. 1997).

²⁵⁶⁷ *Goodyear Tire & Rubber Co. v. Haeger*, 137 S. Ct. 1178, 1186 (2017).

²⁵⁶⁸ *See Thompson v. Does 1-5*, 376 F. Supp. 3d 1322 (N.D. Ga. 2019).

²⁵⁶⁹ *Id.* at 1329 (“The Court did not deny the motion for reconsideration, which kept this suit alive, based on the alleged misrepresentations of fact; it did so because Defendants’ motion was procedurally improper. The hearing on the motion to dismiss was also granted at the *Defendants’* request—not [Plaintiff’s].”).

²⁵⁷⁰ *See Teeter-Totter, LLC v. Palm Bay Int’l, Inc.*, 344 F. Supp. 3d 1100 (N.D. Cal. 2018).

defendant] failed to state claims as a matter of law, the ... [c]ounterclaims were not so frivolous as to warrant an award of attorney's fees and costs."²⁵⁷¹

In contrast, a Minnesota federal district court imposed sanctions for discovery-related misconduct.²⁵⁷² That result held after the defendant failed to disclose information relevant to the issue of monetary relief, even while it proffered an expert witness report on that issue. It did so because of its conviction that the plaintiff would share the information in question to a third party that, unlike the plaintiff, directly competed with the defendant. Although the defendant advised the plaintiff of its withholding of the information and asked the plaintiff to agree to a revised protective order, the plaintiff declined to do so and instead pursued a motion to compel and for sanctions. The court granted the motion after finding the defendant had “engaged in extra-judicial self-help, taking it upon itself to decide what information to disclose while holding other evidence hostage in an effort to force [the plaintiff] to agree to its terms.”²⁵⁷³ It also found that the defendant's conduct was not harmless based on the fact that the deadline for a rebuttal expert report from the plaintiff had come and gone without the defendant complying with its discovery obligations. Although not excluding testimony from the defendant's monetary relief expert, the court therefore awarded the defendant its attorneys' fees as a sanction.²⁵⁷⁴

10. Arbitration

The most interesting opinion to address the question of arbitrability came from the Second Circuit in a dispute originally addressed by a rabbinical tribunal.²⁵⁷⁵ After that body entered its judgment, the prevailing petitioners sought confirmation of the award in federal district court under the Federal Arbitration Act (FAA),²⁵⁷⁶ only to have a respondent unsuccessfully challenge it by raising subject-matter jurisdiction, venue, and merits-based challenges; for their part, the petitioners unsuccessfully challenged the district court's exercise of jurisdiction over the respondent's challenge. In affirming the district court's affirmance of the arbitration award, the Second Circuit held that, because the FAA did not serve as an independent basis for subject-matter jurisdiction, district courts should “look-through” the petition to the underlying substantive controversy to determine whether the

²⁵⁷¹ *Id.* at 1111.

²⁵⁷² *See TrueNorth Cos. v. TruNorth Warranty Plans of N. Am., LLC*, 353 F. Supp. 3d 788 (N.D. Iowa 2018).

²⁵⁷³ *Id.* at 810.

²⁵⁷⁴ *Id.* at 811.

²⁵⁷⁵ *See Landau v. Eisenberg*, 922 F.3d 495 (2d Cir. 2019).

²⁵⁷⁶ 9 U.S.C. § 9 (2018).

claims arose under federal law.²⁵⁷⁷ It then confirmed the district court had reached the proper outcome when applying this methodology, concluding that “[t]he substantive controversy underlying the petition involved questions of federal trademark law, over which district courts unquestionably possess subject matter jurisdiction.”²⁵⁷⁸ In particular, “[b]ecause the district court would have had jurisdiction over the underlying substantive controversy, it had jurisdiction to confirm the arbitration award pursuant to [the] FAA”²⁵⁷⁹

Another opinion turning on the scope of the FAA came from a Connecticut federal district court.²⁵⁸⁰ The plaintiff before that tribunal previously had employed a principal of the lead defendant (who was himself a named individual defendant) as a consultant, and that relationship produced a written agreement containing a clause providing that arbitration was “the only mechanism to settle any dispute, controversy or claim arising out of or relating to this Agreement.”²⁵⁸¹ When the individual defendant and his new company introduced a line of products under marks and trade dresses the plaintiff considered to infringe its rights, the plaintiff filed suit, only to have the defendants move for the dismissal of the action on the theory that, under the FAA, the agreement deprived the court of federal subject-matter jurisdiction over the plaintiff’s claims. Although the defendants argued that the question of arbitrability was within the exclusive jurisdiction, the court disagreed. In its view, “[t]he question whether the parties have submitted a particular dispute to arbitration, i.e., the ‘*question of arbitrability*,’ is ‘an issue for judicial determination unless the parties clearly and unmistakably provide otherwise.’”²⁵⁸² Because the agreement in question did not so clearly and unmistakably provide, the court addressed the question of arbitrability itself in the first instance.²⁵⁸³ Having won that initial battle, however, the plaintiff lost the war, for the court ultimately concluded that the plaintiff’s trademark and unfair causes of action were based on activities by the individual defendant post-dating his agreement with the plaintiff.²⁵⁸⁴

A final notable opinion turning on the arbitrability of the parties’ dispute addressed the effect of a forum-selection clause in a prior agreement designating a nonexistent arbitration service, namely,

²⁵⁷⁷ *Laundau*, 922 F.3d at 498.

²⁵⁷⁸ *Id.*

²⁵⁷⁹ *Id.*

²⁵⁸⁰ *See* *Armor All/STP Prods. Co. v. TSI Prods., Inc.*, 337 F. Supp. 3d 156 (D. Conn. 2018).

²⁵⁸¹ *Id.* at 162.

²⁵⁸² *Id.* at 164 (quoting *Howsam v. Dean Witter Reynolds, Inc.*, 537 U.S. 79, 83 (2002)).

²⁵⁸³ *Id.* at 167.

²⁵⁸⁴ *Id.* at 170, 174.

the “International Arbitrary [sic] Commission.”²⁵⁸⁵ Seeking to avoid arbitration, the plaintiffs argued in a motion to dismiss that, the entirety of the arbitration provisions in the agreement were void, but the court rejected that argument. It initially held that “[w]hile the designation of a non-existent arbitration forum in an arbitration clause, makes the forum selection provision itself ‘null and void,’ that is not dispositive of the arbitration issue.”²⁵⁸⁶ Because the arbitration clause otherwise provided for three arbitrators and a method for their selection, “the parties’ arbitration clause is otherwise valid and exhibits an intent to arbitrate. The parties, thus, must submit any arbitrable disputes to arbitration.”²⁵⁸⁷

E. Evidentiary Matters

1. Admissibility of Expert Witness Testimony

As a general proposition, courts applying Federal Rule of Evidence 702²⁵⁸⁸ admitted the testimony and reports of survey experts and monetary relief experts, but proffered experts in other areas received mixed treatment. For example, in a case in which the validity or genericness of the plaintiff’s mark—UGG for footwear—was hotly disputed, the court proved receptive to an expert report from a linguistics professor describing her searches through various databases and the failure of those searches to disclose any generic uses of the mark.²⁵⁸⁹ The court also credited testimony to similar effect from a footwear historian who concluded from the results of his own research and reviewed catalogs and materials provided to him that “ugg had no significance in the footwear trade or among American consumers” prior to the plaintiff’s adoption of the word as a mark.²⁵⁹⁰ In contrast, however, the court excluded from consideration a report from an Australian intellectual property law

²⁵⁸⁵ See *E. Hedinger AG v. Brainwave Sci., LLC*, 363 F. Supp. 3d 499, 505 (D. Del. 2019).

²⁵⁸⁶ *Id.* at 507.

²⁵⁸⁷ *Id.* at 508.

²⁵⁸⁸ That rule provides:

A witness who is qualified as an expert by knowledge, skill, experience, training, or education may testify in the form of an opinion or otherwise if:

- (a) the expert’s scientific, technical, or other specialized knowledge will help the trier of fact to understand the evidence or to determine a fact in issue;
- (b) the testimony is based on sufficient facts or data;
- (c) the testimony is the product of reliable principles and methods; and
- (d) the expert has reliably applied the principles and methods to the facts of the case.

Fed. R. Evid. 702.

²⁵⁸⁹ See *Deckers Outdoor Corp. v. Australian Leather Pty. Ltd.*, 340 F. Supp. 3d 706, 714 (N.D. Ill. 2018).

²⁵⁹⁰ *Id.* at 715.

professor concerning the alleged unprotectability of the mark in her country; with respect to that testimony, it concluded that “the legal status of the term in Australia is irrelevant, and the legal expert is not qualified to testify about consumer perceptions.”²⁵⁹¹

Another split decision appeared in the opinion of an Ohio federal district court weighing the eligibility of a lollipop producer for a preliminary injunction against a competitor that allegedly redesigned its packaging to imitate that of the plaintiff.²⁵⁹² In support of its bid for interlocutory relief, the plaintiff sought to introduce evidence from an alleged expert in marketing and branding. Although allowing the witness to opine on matters related to product development, the court found his report’s treatment of other (unidentified) issues to be fatally defective because of his conclusory opinions resting on unverified methodology. In particular, the court noted, the witness had “no ‘specialized knowledge’ of many of the topics on which he opines,”²⁵⁹³ meaning that “his opinion is informed by various blogs and articles he discovered through internet searches conducted in preparation of this case.”²⁵⁹⁴ Moreover, “though he quotes extensively to these articles and blogs in the report and bases his opinion on them, [the witness] did not know many of the sources or authors and was unable to attest to their reputation.”²⁵⁹⁵ “Finally,” the court found, “[the witness] did not verify the underlying data and methodology used to reach the conclusions upon which he relies and quotes.”²⁵⁹⁶ The outcome therefore was a partial grant of the defendant’s motion to exclude.

2. Admissibility of Other Evidence and Testimony

Although the Supreme Court may have held in *TrafFix Devices, Inc. v. Marketing Displays, Inc.*²⁵⁹⁷ that [a] utility patent is strong evidence that the features therein claimed are functional,²⁵⁹⁸ the Seventh Circuit confirmed that not all utility patent filings proffered by a defendant necessarily merit introduction into evidence.²⁵⁹⁹ The court did so in a case in which the parties tried the issue of the nonfunctionality or functionality of the configuration of

²⁵⁹¹ *Id.* at 716.

²⁵⁹² *See Spangler Candy Co. v. Tootsie Roll Indus.*, 372 F. Supp. 3d 588 (N.D. Ohio), *appeal dismissed*, No. 19-3227, 2019 WL 2564576 (6th Cir. May 10, 2019).

²⁵⁹³ *Id.* at 595.

²⁵⁹⁴ *Id.*

²⁵⁹⁵ *Id.*

²⁵⁹⁶ *Id.*

²⁵⁹⁷ 532 U.S. 23 (2001).

²⁵⁹⁸ *Id.* at 29.

²⁵⁹⁹ *See Bodum USA, Inc. v. A Top New Casting Inc.*, 927 F.3d 486 (7th Cir. 2019).

a coffee press to a jury. At trial, the defendant sought to cross-examine an expert witness retained by the plaintiff using certain utility patents its counsel had identified. The court articulated two reasons why the district court had not abused its discretion by excluding the patents, the first of which was that the defendant's proposed exhibits consisted only of portions of the patents, namely, their drawings. The second was that, when the district court examined the patents in their entireties, it concluded that they did not claim the appearance of the plaintiff's configuration.²⁶⁰⁰ Under those circumstances, "[p]ermitting the jury to view and consider the patents would cause confusion as to the proper inquiry for functionality."²⁶⁰¹

The Seventh Circuit was not the only court to order the exclusion of evidence. For example, a California federal district court held that defendants responding to a motion for summary judgment by their adversary were not entitled to rely upon a one-page excerpt from a collegiate senior thesis to bolster their claim that the plaintiff had abandoned its rights to a mark misappropriated by the defendants.²⁶⁰² According to the excerpt, the plaintiff had discontinued use of its mark to rid itself of a "tarnished reputation," but the plaintiff successfully objected to its introduction because the witness purporting to authenticate it had "no personal knowledge of who the author is, the author's background, how [it] was created, or what materials the author considered."²⁶⁰³ Exclusion therefore was appropriate because "Defendants have not established [the witness] has the personal knowledge required to authenticate the document."²⁶⁰⁴ Moreover, to the extent the defendants sought to rely upon the thesis for a quotation from a former employee of a subsidiary of the plaintiff speculating on the lost value of the allegedly abandoned mark, exclusion was additionally appropriate because of the hearsay nature of the quotation.²⁶⁰⁵

A hearsay objection similarly tripped up certain testimony and exhibits proffered by a plaintiff before a Texas federal district court.²⁶⁰⁶ Certain of the plaintiff's attempted showings were aimed at establishing a geographic overlap between the parties' respective markets, but, because they depended on out-of-court statements by third parties as to their putative locations, they were inadmissible

²⁶⁰⁰ *Id.* at 496.

²⁶⁰¹ *Id.* at 497.

²⁶⁰² See *AECOM Energy & Constr., Inc. v. Ripley*, 348 F. Supp. 3d 1038 (C.D. Cal.), reconsideration denied, No. CV 17-5398-RSWL-SSx, 2019 WL 2610953 (C.D. Cal. Apr. 24, 2019), appeal docketed, No. 19-55588 (9th Cir. May 23, 2019).

²⁶⁰³ *Id.* at 1048.

²⁶⁰⁴ *Id.*

²⁶⁰⁵ *Id.*

²⁶⁰⁶ See *Cross Trailers, Inc. v. Cross Trailer Mfg. & Sales, LLC*, 363 F. Supp. 3d 774 (W.D. Tex. 2018).

hearsay.²⁶⁰⁷ Accounts of contacts by other third parties put forward by the plaintiff to prove actual confusion between the marks in question suffered the same fate to the extent they described the putative reasons why one third party would not do business with the plaintiff and why another had contacted the plaintiff by mistake.²⁶⁰⁸

Hearsay also proved an insurmountable obstacle to a pair of defendants seeking to demonstrate the genericness of the trademark they were accused of infringing.²⁶⁰⁹ Much of the defendants' showing of alleged genericness rested on the mark's status in Australia and, consistent with that focus, they sought to introduce a declaration from a proceeding in the Australian Trade Marks Office supported by exhibits comprising "Australian telephone books, advertisements, and dictionaries using the term."²⁶¹⁰ Citing the unfilled requirements of 28 U.S.C. § 1746(1) for declarations executed outside the United States,²⁶¹¹ the court found the declaration inadmissible hearsay. "As a result," it concluded, "the exhibits are not properly authenticated, and I do not consider them."²⁶¹²

Of course, the resolution of admissibility disputes sometimes favored the parties tendering the disputed evidence or testimony.²⁶¹³ One notable example of such a resolution came in an appeal to the First Circuit from a jury finding that the counterclaim plaintiff—a former guitarist for the rock band Boston—had not complied with a particular term under a prior settlement agreement between the parties.²⁶¹⁴ The term in question prohibited the defendant's use of the BOSTON mark except in the phrase "Formerly of Boston, which the plaintiff alleged had been violated by a third party's creation of a "pop-up" music video replete with references to the BOSTON mark. Objecting to the jury's apparent

²⁶⁰⁷ *Id.* at 786.

²⁶⁰⁸ *Id.* at 785.

²⁶⁰⁹ *See Deckers Outdoor Corp. v. Australian Leather Pty. Ltd.*, 340 F. Supp. 3d 706 (N.D. Ill. 2018).

²⁶¹⁰ *Id.* at 715.

²⁶¹¹ 28 U.S.C. § 1746(1) (2018) (Wherever, under any law of the United States . . . any matter is required or permitted to be supported, evidenced, established, or proved by the sworn declaration . . . in writing of the person making the same . . . such matter may . . . be supported . . . by the unsworn declaration . . . in writing of such person which is subscribed by him, as true under penalty of perjury, and dated, in substantially the following form: (1) If executed without the United States: 'I declare (or certify, verify, or state) under penalty of perjury under the laws of the United States of America that the foregoing is true and correct. Executed on (date).

(Signature)').").

²⁶¹² *Id.*

²⁶¹³ *See, e.g., id.* at 786 (allowing testimony describing inquiries (as opposed to statements) by third parties).

²⁶¹⁴ *See Scholz v. Goudreau*, 901 F.3d 37 (1st Cir. 2018).

reliance on the video, the defendant argued on appeal that the district court should have excluded the video as a constitutionally protected artistic parody, especially in the absence of any evidence of his involvement in it.

The First Circuit declined to overturn the district court's admission of the video as an abuse of discretion. To begin with, it held, "the music video . . . was relevant to an issue [submitted to the jury] at trial: whether [the defendant] was liable for contributory or vicarious trademark infringements contained in the video."²⁶¹⁵ Equally to the point, conduct causing confusion in the marketplace typically falls outside the scope of the First Amendment, and "[a] 'pop-up' video that features two former members of BOSTON, contains text describing [the defendant] and [the band's former] drummer . . . as founding original members of BOSTON, discusses BOSTON's record sales and the artwork on BOSTON's first album cover, and displays old footage of BOSTON, would certainly have the potential to cause consumer confusion."²⁶¹⁶ Finally, in the appellate court's estimation, the defendant had failed both to preserve the issue for appeal and to establish that the video, "and not other pieces of evidence," had led the jury to find against him.²⁶¹⁷

The First Circuit's opinion was not the only one favoring the admissibility of evidence. Following a jury verdict favoring a competitor it had accused of trade dress infringement, a bottle manufacturer sought a new trial by arguing the court had erred in admitting into evidence numerous bottles produced by third parties and allegedly similar to the plaintiff's own bottles.²⁶¹⁸ As summarized by the court, one basis of the plaintiff's motion was that, "[o]verwhelmed with the physical presence of these bottles in evidence, the jury would [have] incorrectly assume[d] that consumer awareness was proportional to the distribution of bottles before them and that [the plaintiff's] trade dress had no secondary meaning."²⁶¹⁹ Declining to grant a new trial on that basis, the court noted the defendant's disclosure of at least some of the third-party designs in enough time for the plaintiff "to discover the market share and advertising revenue of these other brands, and then to make specific arguments to the jury about the probative value of these bottles";²⁶²⁰ "[h]aving opted not to pursue this equally accessible and easily discoverable information," the court held, "[the plaintiff] cannot now complain that it is prejudiced without it."²⁶²¹

²⁶¹⁵ *Id.* at 51.

²⁶¹⁶ *Id.* at 52.

²⁶¹⁷ *Id.*

²⁶¹⁸ See *Can't Live Without It, LLC v. ETS Express, Inc.*, 373 F. Supp. 3d 434 (S.D.N.Y. 2018).

²⁶¹⁹ *Id.* at 440.

²⁶²⁰ *Id.* at 441.

²⁶²¹ *Id.*

Moreover, and in any case, “[the plaintiff] cross-examined the relevant . . . witnesses [of the defendant] regarding their knowledge of the market share of the bottles they bought, and established that they had no idea how many other were purchased or how many customers were aware of these brands.”²⁶²² Because the jury therefore was “placed on guard” against the claimed prejudice underlying the plaintiff’s motion, a new trial was unwarranted.²⁶²³

Third-party usage also was the subject of an evidentiary dispute in a dispute between competitors in the real estate business.²⁶²⁴ En route to a finding that the counterclaim plaintiff’s claimed marks were, in fact, generic and unprotectable, a Virginia federal district court addressed, and rejected, a number of objections to the counterclaim defendant’s evidentiary proffers. One such proffer was that of newspaper evidence, which the counterclaim defendant argued was unauthenticated; the court disagreed, holding it self-authenticating under Rule 902(b) of the Federal Rules of Evidence.²⁶²⁵ The court also admitted “evidence [of genericness] from the Internet, including Google search results and other evidence,” which it held was authenticated under Rule 901(b)(4) in light of the “appearance, contents, substance, internal patterns, or other distinctive characteristics” of the items in question.²⁶²⁶ Finally, it held, “a number of documents in the record are taken directly from the PTO’s website, which may be judicially noticed.”²⁶²⁷

Other requests for courts to take judicial notice of USPTO records were equally successful,²⁶²⁸ as were those covering other

²⁶²² *Id.*

²⁶²³ *Id.*

²⁶²⁴ See *Express Homebuyers USA, LLC v. WBH Mktg. Inc.*, 323 F. Supp. 3d 784 (E.D. Va.), *reconsideration denied*, No. 1:17-CV-736, 2018 WL 6616675 (E.D. Va. Aug. 29, 2018), *appeal docketed*, No. 18-2149 (4th Cir. Oct. 2, 2018).

²⁶²⁵ *Id.* at 788 n.2.

²⁶²⁶ *Id.* at 788 n.3.

²⁶²⁷ *Id.*

²⁶²⁸ See, e.g., *Caiz v. Roberts*, 382 F. Supp. 3d 942, 947 (C.D. Cal.) (similarly taking judicial notice of the “file history” of plaintiff’s registration “[b]ecause the document is not subject to reasonable dispute, is capable of accurate and ready determination by resort to sources whose accuracy cannot reasonably be questioned, and is a matter of public record”), *appeal dismissed*, No. 19-55611, 2019 WL 6331647 (9th Cir. Aug. 30, 2019); *Knowles-Carter v. Feyonce, Inc.*, 347 F. Supp. 3d 217, 221 n.2 (S.D.N.Y. 2018) (“The Court takes judicial notice of the trademark registrations and other publicly available USPTO records to the extent that they are relevant in deciding this motion [for partial summary judgment.]”); *Express Homebuyers USA, LLC v. WBH Mktg. Inc.*, 323 F. Supp. 3d 784, 789 n.3 (E.D. Va.) (“[A] number of [disputed] documents in the record are taken directly from the PTO’s website, which may be judicially noticed.”), *reconsideration denied*, No. 1:17-CV-736, 2018 WL 6616675 (E.D. Va. Aug. 29, 2018), *appeal docketed*, No. 18-2149 (4th Cir. Oct. 2, 2018); *Disney Enters. v. Sarelli*, 322 F. Supp. 3d 413, 425 n.2 (S.D.N.Y.) (“[T]his Court is entitled to take judicial notice of Plaintiffs’ ownership of the relevant trademarks and copyrights from the publicly filed certificates of registration and file

materials,²⁶²⁹ including Wayback Machine search results,²⁶³⁰ but some produced varying outcomes. Thus, for example, one court judicially noticed an FDA regulation but refused to do the same with respect to “various documents, including books, journal articles, [other] regulations, and many others.”²⁶³¹ A different court similarly splitting the evidentiary baby took judicial notice of securities filings by the plaintiff but warned the defendants that “[t]he Court does not, however, take judicial notice of reasonably disputed facts contained within the judicially noticed documents.”²⁶³² And still another declined to take judicial notice altogether that the defendant was a federally regulated credit union and that the National Credit Union Administration insured its deposits for purposes of the inquiry into whether the defendant had used a particular mark in commerce.²⁶³³

F. Trademark- and Service Mark-Related Transactions

1. Interpretation and Enforcement of Trademark and Service Mark Assignments

Unusually, the opinion devoting the most attention to an assignment of trademark rights arose from a potential such transaction and not an actual one.²⁶³⁴ It came from a California federal district court before which the government had successfully prosecuted a criminal racketeering action against a motorcycle club and a number of the club’s members. Following up on a jury’s guilty verdicts, the government sought the forfeiture of several collective membership marks owned by the club. Although denying that relief for other reasons, the court expressed doubt as to whether the proposed forfeiture would be anything other than an invalid assignment in gross. In the court’s view, “the collective membership marks would be forcibly transferred to the United States in gross

wrappers.”), *reconsideration denied*, No. 16 CIV. 2340 (GBD), 2018 WL 5019745 (S.D.N.Y. Sept. 26, 2018).

²⁶²⁹ See, e.g., *Great Am. E & S Ins. Co. v. Theos Med. Sys., Inc.*, 357 F. Supp. 3d 953, 959 n.1 (N.D. Cal. 2019) (taking judicial notice of pleadings in underlying suit against insured), *appeal docketed*, No. 19-15351 (9th Cir. Feb. 28, 2019); *San Diego Comic Convention v. Dan Farr Prods.*, 336 F. Supp. 3d 1191, 1198 n.2 (S.D. Cal. 2018) (taking judicial notice of contents of defendants’ website).

²⁶³⁰ See *Safeway Transit LLC v. Disc. Party Bus, Inc.*, 334 F. Supp. 3d 995, 1000 n.5 (D. Minn. 2018), *appeal docketed*, No. 18-2990 (8th Cir. Sept. 17, 2018).

²⁶³¹ See *Obesity Research Inst., LLC v. Fiber Research Int’l, LLC*, 310 F. Supp. 3d 1089, 1106 (S.D. Cal.), *motion to certify denied*, No. 15-cv-00595-BAS-MDD, 2018 WL 1791611 (S.D. Cal. Apr. 16, 2018).

²⁶³² *Allergan USA, Inc. v. Prescribers Choice, Inc.*, 364 F. Supp. 3d 1089, 1095 (C.D. Cal. 2019).

²⁶³³ See *San Diego Cty. Credit Union v. Citizens Equity First Credit Union*, 360 F. Supp. 3d 1039, 1049 (S.D. Cal. 2019).

²⁶³⁴ See *United States v. Mongol Nation*, 370 F. Supp. 3d 1090 (C.D. Cal. 2019).

because the goodwill associated with the marks cannot be transferred. What the . . . collective membership marks represent is membership in the . . . motorcycle club, which will continue to exist after this case.”²⁶³⁵ Thus, the marks’ special nature distinguished the government’s forfeiture request from those in past cases involving more conventional trademarks and service marks.²⁶³⁶

Another notable reported opinion turned on the proper interpretation of the prohibition in Section 10(a)(1) of the Act²⁶³⁷ on the assignment of intent-to-use applications prior to the filing of verified statements of use of the marks covered by the applications.²⁶³⁸ The court’s treatment of that issue had its origins in an ITU application listing two individuals as joint applicants. After the application’s filing date but before the submission of a statement of use, the applicants executed a document in which one transferred to the other “all right, title, and interest throughout the world in and to the [applied-for mark],” as well as “any and all goodwill of the business connected with the use of, and symbolized by, the same, and the business in connection with which the trademark is intended to be used.”²⁶³⁹ Ownership of the registration maturing from the application eventually passed to the plaintiff, which asserted it as a basis for its alleged priority of rights.

The defendants responded to that assertion by moving to dismiss it for failure to state a claim. The defendants’ motion argued the transaction between the applicants violated Section 10(a)(1) and that the registration necessarily was void as a result. Relying on Trademark Trial and Appeal Board authority addressing the identical question,²⁶⁴⁰ the court disagreed, holding that the transfer in question was more in the nature of a relinquishment of ownership rights by one of the joint owners than a true assignment to a different legal entity. “In this case,” the court held, “the Assignment Document only *removed* [one applicant] as an owner of the intent-to-use registration. [The second applicant] owned the mark before and after the Assignment Document’s execution; there was thus no transfer to another.”²⁶⁴¹ Under these circumstances, “the transfer executed via the Assignment Document was not an assignment subject to § 1060(a)(1), and [the lead defendant’s counterclaim for cancellation] must be dismissed.”²⁶⁴²

²⁶³⁵ *Id.* at 1125.

²⁶³⁶ *See, e.g.,* Cash Processing Servs. v. Ambient Entm’t, Inc., 418 F. Supp. 2d 1227, 1229 (D. Nev. 2006).

²⁶³⁷ 15 U.S.C. § 1060(a)(1) (2018).

²⁶³⁸ *See* Teeter-Totter, LLC v. Palm Bay Int’l, Inc., 344 F. Supp. 3d 1100 (N.D. Cal. 2018).

²⁶³⁹ *Id.* at 1107.

²⁶⁴⁰ *See* Amazon Techs., Inc. v. Wax, 95 U.S.P.Q.2d 1865 (T.T.A.B. 2010).

²⁶⁴¹ *Teeter-Totter*, 344 F. Supp. 3d at 1107.

²⁶⁴² *Id.*

In contrast, two federal appellate opinions concluded that assignments of rights had, in fact occurred. In the dispute leading to the first one, the Fifth Circuit sustained the assignment of rights to the marks and trade dress associated with a single-location restaurant.²⁶⁴³ The transaction documents conveyed the entire business to the assignees and, according to the court, “[w]hen selling an entire business, the rights to associated trademarks are necessarily sold unless at least two conditions are met: (1) the contract expressly reserves some right and interest in the trademark, and (2) the seller retains some of the business’s goodwill.”²⁶⁴⁴ Because neither of those exceptions applied, the assignees had received the marks and trade dress along with the rest of the business. Although the assignors attempted to escape the court’s holding by arguing that the effect of the assignment was limited to the single restaurant they operated at the time of the transaction (which would have allowed them to begin using the marks and trade dress in connection with new restaurants), the court rejected that claim. Instead, it held:

We have not been able to locate a case, and [the assignors] point[] to none, where a trademark owner sells his sole business, assigns a related trademark only as to that single business location, and retains a right to use the trademark when no other business or portion of the business with goodwill symbolized by that trademark exists. The point is not that a geographically bounded right to a trademark can never be assigned. The point is that in the context of this transaction it could not.²⁶⁴⁵

The second opinion came from the Third Circuit.²⁶⁴⁶ When the members of a limited partnership fell out, a former partner who claimed he had coined a mark used by the partnership sued on the theory that he was the mark’s rightful owner. That claim was undone by a 2004 contract between the former partner and the limited partnership’s predecessor in interest in which the former partner agreed that all trademarks “applied for or registered” by the predecessor would belong to it.²⁶⁴⁷ Although a subsequent agreement between the parties in 2004 modified the 2002 agreement’s treatment of “intellectual property,” the precisely worded definition of “intellectual property” in the 2004 agreement

²⁶⁴³ See *Uptown Grill, L.L.C. v. Camellia Grill Holdings, Inc.*, 920 F.3d 243 (5th Cir. 2019).

²⁶⁴⁴ *Id.* at 248-49.

²⁶⁴⁵ *Id.* at 249.

²⁶⁴⁶ See *Sköld v. Galderma Labs.*, 917 F.3d 186 (3d Cir. 2019).

²⁶⁴⁷ *Id.* at 189.

did not include “trademarks.” Accordingly, the predecessor (and therefore the limited partnership) owned the disputed mark.²⁶⁴⁸

2. Interpretation and Enforcement of Trademark and Service Mark Licenses

A number of reported opinions arose out of disputed language in licensing agreements, with perhaps the most consequential coming from a New York federal district court.²⁶⁴⁹ The parties before it previously had entered into a license allowing the licensor to withhold approval for new products bearing the licensed mark, provided that the licensor not do so unreasonably. When the licensor declined to extend its approval, the resulting litigation forced the court to address the question of whether the licensor had behaved reasonably, which the court held turned on the following question: “Whether [the licensor] had an objective basis that would be acceptable from a reasonable trademark owner’s viewpoint.”²⁶⁵⁰ In formulating the inquiry in this manner, the court held that the reasonableness determination must rest on facts known to the licensor at the time,²⁶⁵¹ that the licensor’s motive in withholding consent was irrelevant,²⁶⁵² and that the licensee bore the burden of proving that the licensor had acted unreasonably.²⁶⁵³ It also rejected the licensee’s argument that an objectively reasonableness standard necessarily incorporated requirements of fairness, good faith, and non-arbitrariness.²⁶⁵⁴ Finally, it held that the licensor need not articulate material reasons for withholding its approval at the time of the withholding; rather, the licensor was required to identify those reasons only in response to an initial showing of unreasonableness by the licensee.²⁶⁵⁵

Other reported opinions addressed different license-related issues. Under the doctrine of licensee estoppel, a licensee can establish protectable rights to a licensed mark vis-a-vis its licensee even after the license runs its course. As an Eighth Circuit opinion demonstrated, however, licensee estoppel has its limits.²⁶⁵⁶ The court’s discussion of the doctrine arose from litigation in which a licensor sought to establish the protectability of its claimed marks

²⁶⁴⁸ See *id.* at 194-95.

²⁶⁴⁹ See *IGT v. High 5 Games, LLC*, 380 F. Supp. 3d 390 (S.D.N.Y. 2019).

²⁶⁵⁰ *Id.* at 393.

²⁶⁵¹ *Id.* at 395-96.

²⁶⁵² *Id.* at 396.

²⁶⁵³ *Id.*

²⁶⁵⁴ *Id.* at 397-98.

²⁶⁵⁵ *Id.* at 399.

²⁶⁵⁶ See *Sturgis Motorcycle Rally, Inc. v. Rushmore Photo & Gifts, Inc.*, 908 F.3d 313 (8th Cir. 2018), *on remand*, 129 U.S.P.Q.2d 1392 (D.S.D. 2019).

by pointing to a license it had issued to one of several defendants. Although the license granted the licensed defendant the right to use a single mark, its preamble recited that the plaintiff owned several other marks. Affirming the district court's rejection of the plaintiff's invocation of licensee estoppel, the appellate court noted as an initial matter that "[l]icensee estoppel precludes only licensees of a mark from contesting it; 'other parties, even those closely affiliated with the licensee, are not foreclosed.'"²⁶⁵⁷ Moreover, because the sole defendant that was itself a licensee had used only a single mark under its agreement with the plaintiff, the license's preamble did not have dispositive effect with respect to the other marks at issue. "It would be antithetical in any event to the pro-competitive purposes of trademark law," the court concluded, "to allow a licensor to lay claim to marks that its licensees have not used by inserting superfluous language into its licensing agreements."²⁶⁵⁸

The same Eighth Circuit opinion addressed another aspect of licensing practice but, in doing so, it demonstrated a much looser understanding of the issue at stake. In addition to claiming licensee estoppel, the plaintiff attempted to establish the acquired distinctiveness of its geographically descriptive mark by proffering testimony and evidence of sales by a licensee. The court was unimpressed, and it overturned a jury finding of distinctiveness with the observation that "[the plaintiff] . . . appears to assume that whenever an independent user of the [claimed mark] on . . . goods and services becomes its licensee, all of that person's pre-licensed uses of the word are transformed into uses of it as [the plaintiff's] mark."²⁶⁵⁹ Contrary to the court's understanding of the significance of a license on these facts, however, the plaintiff's assumption was correct: Under the merger doctrine, "[a] licensee's prior claims of any independent rights to a trademark are lost, or merged into the license, when he accepts his position as licensee, thereby acknowledging the licensor owns the marks and that his rights are derived from the licensor and enure to the benefit of the licensor."²⁶⁶⁰

The Fifth Circuit similarly declined to give the merger doctrine its usual effect.²⁶⁶¹ At a better time in their relationship, the parties had entered into a transaction that the court held had transferred the plaintiffs' rights to the defendants. Shortly after that transaction, however, the parties entered into another agreement purporting to license the defendants to use some of the same properties covered by the transaction document. Under a strict

²⁶⁵⁷ *Id.* at 321 (quoting *Fair Isaac Corp. v. Experian Info. Sols., Inc.*, 650 F.3d 1139, 1150 (8th Cir. 2011)).

²⁶⁵⁸ *Id.* at 322.

²⁶⁵⁹ *Id.* at 325.

²⁶⁶⁰ *Bunn-O-Matic Corp. v. Bunn Coffee Serv., Inc.*, 88 F. Supp. 2d 914, 923 (C.D. Ill. 2000).

²⁶⁶¹ *See Uptown Grill, L.L.C. v. Camellia Grill Holdings, Inc.*, 920 F.3d 243 (5th Cir. 2019).

application of the merger document, the later transaction would trump the earlier one, and ownership of the rights in question would automatically revert to the plaintiffs as licensors. The court declined to give the license that effect, however, concluding instead that “[t]he parties appear to have made a mutual mistake as to a material, basic assumption upon which the License Agreement was made: that [the plaintiffs] had rights to license.”²⁶⁶² Because the license agreement did not supersede or modify the earlier transaction, that assumption was misplaced.²⁶⁶³

In a case not requiring the court to address the merger doctrine, a Louisiana federal district court found the counterclaim plaintiffs had licensed the counterclaim defendant to use a mark at a particular address in the city of New Orleans.²⁶⁶⁴ When the counterclaim defendant began using the mark elsewhere, the counterclaim plaintiffs sought preliminary injunctive relief, claiming both infringement and breach of the license agreement. After holding the counterclaim plaintiffs entitled to prevail on the former theory, the court reached the same conclusion under the latter. Although the license in question did not affirmatively restrict the counterclaim defendant from using the licensed mark at any other location, the court held such a restriction was necessarily contemplated by that document. In particular, it concluded, “if a party owns a mark, then a license to use that mark implies an obligation not to use the mark outside the scope of the license.”²⁶⁶⁵ The counterclaim defendant’s breach of the license therefore was an additional basis for liability.

Another reported opinion found multiple breaches of a license between the City of New York and its licensee for the TAVERN ON THE GREEN mark, which the license permitted the licensee to use in connection with a restaurant in Central Park, as well as with cooking oils and salad dressings.²⁶⁶⁶ The license both required the licensee to avoid mentioning Central Park, or using any pictures or other depictions of the park, or its structures without the city’s consent and to use certain disclaimers. When the City learned the licensee had violated the license’s prohibitory language, it objected on March 18, 2016, and then, eighteen business days later, sent a notice of termination. On February 16, 2017, the City forwarded its objection to another claimed violation of the license’s prohibitory language, this one by a consultant acting on the licensee’s behalf,

²⁶⁶² *Id.* at 250.

²⁶⁶³ *Id.*

²⁶⁶⁴ See *Helpful Hound, L.L.C. v. New Orleans Bldg. Corp.*, 331 F. Supp. 3d 581 (E.D. La. 2018).

²⁶⁶⁵ *Id.* at 603.

²⁶⁶⁶ See *City of N.Y. v. Tavern on the Green Int’l LLC*, 351 F. Supp. 3d 680 (S.D.N.Y. 2018).

after which it filed suit on February 24, 2017—eight business days after its last objection but 217 days after its first one.

Seeking to avoid liability, the licensee argued the City had breached the license by failing to allow the licensee to avail itself of a twenty-business-day cure period, but the court held otherwise on the parties' motions for summary judgment. It accepted the City's argument that the license did not require a formal notice of termination, much less one following the cure period; rather, the license authorized a suit twenty days after a notice of breach. Consequently, the City had not breached the license by filing a lawsuit challenging the licensee's initial violation.²⁶⁶⁷

The same could not be said where the licensee's second violation was concerned, however, because the City had waited only eight business days after its notice of breach before filing suit. Nevertheless, the court identified two reasons for declining to accept the licensee's argument that the City's failure to satisfy a condition precedent precluded the City for claiming a breach by the licensee. First, the court found, the licensee had responded to the City's last notice of breach by insisting its advertising complied with the license's terms. Second, and "more importantly[,] [the licensee's] continued infringement even after the suit was commenced makes clear that [the licensee] never would have availed itself of the opportunity to cure" ²⁶⁶⁸ "Indeed," the court found, "the [licensee's consultant's] website persisted in posting the prohibited statements as late as July 27, 2018—more than a year after the initiation of this suit."²⁶⁶⁹

Having thus held the City entitled to prevail on its breach of contract cause of action, the court then rejected the licensee's claim that the City had itself violated the license by opposing an application by the licensee to register the TAVERN ON THE GREEN mark for salad dressing and cooking oils. As the court pointed out, the language of the license upon which the licensee relied allowed the licensee to register that mark in "combin[ation] with and accompanied by differentiating language in the nature of a geographic or location identifier . . . and used for restaurant, bar and catering services."²⁶⁷⁰ Because the licensee's application did not include "restaurant, bar and catering services" in its identification of goods and services, and, additionally, did not cover the mark with the required differentiating language, the application did not fall within the safe harbor established by the license.²⁶⁷¹

²⁶⁶⁷ *Id.* at 692.

²⁶⁶⁸ *Id.* at 693.

²⁶⁶⁹ *Id.*

²⁶⁷⁰ *Id.* at 694 (alteration in original).

²⁶⁷¹ *Id.* at 694-95.

Nevertheless, not all licensees would up on the losing side of disputes with their licensors, and, indeed, one group of franchisees successfully defended themselves against allegations that their use of the plaintiffs' mark during the pendency of the franchise agreement had been unauthorized (and therefore infringing).²⁶⁷² Going through the franchisees' obligations under the parties' agreements point-by-point, the court found each satisfied. Worse still for the franchisors' case, the summary judgment record contained evidence that the franchisors had gone so far as to announce the opening of the franchisees' store in their corporate newsletter and to submit photographs of that store as specimens in support of an application to register the disputed mark. In the face of overwhelming evidence that the franchisors' use the mark was authorized (and therefore not infringing), the franchisors accused two of the franchisees of fraudulently inducing the franchisors' entry into the agreements by failing to disclose they were married to each other. The court rejected that argument as a matter of law: "[The franchisors] . . . offer no evidence to demonstrate this contention. Furthermore, [the franchisors] have also failed to demonstrate how it [sic] relied on the allegedly fraudulent misrepresentation and did so to their detriment."²⁶⁷³

3. Interpretation and Enforcement of Settlement Agreements

Although releases of liability were not the only subjects of litigation arising from prior settlement agreements,²⁶⁷⁴ they took center stage in four reported opinions. In the case producing the first, the agreement in question recited that the counterclaim defendant enjoyed the right to use its corporate name and a logo "for its existing business as conducted on the date hereof."²⁶⁷⁵ Seven years later, they entered into a technology transfer agreement that provided, inter alia, for the termination of the earlier agreement and for the release of all rights they may have received under it "relating to limitations on general releases."²⁶⁷⁶ Based on that release, the counterclaim plaintiff claimed the counterclaim defendant had waived its ability to use the corporate name and logo referenced by

²⁶⁷² See *Xiao Wei Yang Catering Linkage in Inner Mongolia Co. v. Inner Mongolia Xiao Wei Yang USA, Inc.*, 340 F. Supp. 3d 70 (D. Mass. 2018), *appeal dismissed*, No. 18-2037, 2019 WL 1927139 (1st Cir. Feb. 21, 2019).

²⁶⁷³ *Id.* at 78.

²⁶⁷⁴ See, e.g., *Steer Mach. Tool & Die Corp. v. SS Niles Bottle Stoppers, LLC*, 331 F. Supp. 3d 429, 433-34 (M.D. Pa. 2018) (denying motion to dismiss breach-of-contract cause of action for failure to state a claim after identifying "eighteen paragraphs of allegations [in the complaint] that pertain directly to violations of the settlement agreement").

²⁶⁷⁵ *Welding Eng'rs Ltd. v. NFM/Welding Eng'rs, Inc.*, 352 F. Supp. 3d 416, 423 (E.D. Pa. 2018).

²⁶⁷⁶ *Id.* at 424.

the earlier agreement; in other words, it argued that the sole source of the counterclaim defendant's ownership of the name and logo was the earlier agreement. Granting the counterclaim defendant's motion for summary judgment, the court disagreed. Contrary to the counterclaim plaintiff's reading of the second agreement, the court interpreted the language in question as releasing the parties' rights only as to the limitations on general releases, rather than releasing any and all rights the parties may have had under the earlier agreement.²⁶⁷⁷

Italian law governed the settlement agreement leading to the second opinion.²⁶⁷⁸ That agreement barred the lead defendant from using the VERSACE mark for any purpose other than to comply with a legal requirement that it use its full corporate name, namely, "Versace 19.69 Abbigliamento Sportivo, S.R.L." When goods bearing that name appeared in United States markets, the plaintiffs filed suit alleging infringement and likely dilution, which led the defendants improbably to accuse the plaintiffs of breach of contract in a counterclaim. Granting the plaintiffs' motion for summary judgment, the court found the defendants' counterclaim fatally flawed and not merely because "[the lead defendant] admitted in this litigation that no U.S. law requires [it] to place its full name on products involved in the present lawsuit."²⁶⁷⁹ Instead, and in addition to that admission against interest, "numerous Italian courts" had rejected the defendants' argument that the agreement in fact allowed them to use the full name even in the absence of a legal requirement to do so.²⁶⁸⁰

A final opinion addressing the significance of a prior settlement agreement did not definitively resolve one issue at stake but instead merely declined to do so as a matter of law in response to a motion to dismiss.²⁶⁸¹ The plaintiff's complaint accused the defendant in part of having purchased certain ad words in violation of the earlier agreement, and it supported that allegation with a screenshot purportedly documenting that violation. In response, the defendant argued that the plaintiff's breach-of-contract claim was a legal conclusion not entitled to a presumption of truth at the pleadings stage. The court rejected that argument, holding instead that the alleged breach was "a specific fact that does not require a chain of inferences."²⁶⁸²

²⁶⁷⁷ *Id.* at 430-31.

²⁶⁷⁸ *See Gianni Versace, S.p.A. v. Versace 19.69 Abbigliamento Sportivo SRL*, 328 F. Supp. 3d 1007 (N.D. Cal. 2018), *appeal dismissed*, No. 19-15188, 2019 WL 2005744 (9th Cir. Apr. 17, 2019).

²⁶⁷⁹ *Id.* at 1025.

²⁶⁸⁰ *Id.* at 1025-26.

²⁶⁸¹ *See My Pillow, Inc. v. LMP Worldwide, Inc.*, 331 F. Supp. 3d 920 (D. Minn. 2018).

²⁶⁸² *Id.* at 931.

Nevertheless, the court *did* dismiss another basis of the plaintiff's claim of breach, namely, that the defendant used its mark in a manner not authorized by the agreement. On that issue, the court determined, "[t]he complaint's only allegation pertaining to the [defendant's] mark is a screen shot of [the defendant's] website featuring the [defendant's] mark and photographs of [its goods]." ²⁶⁸³ That use appeared to the court to be consistent with the parties' agreement; in any case, however, "because this allegation is too conclusory to be entitled to a presumption of truth, the complaint fails to allege facts supporting a determination that [the defendant's] use of the [defendant's] mark was unauthorized." ²⁶⁸⁴

G. The Relationship Between the Lanham Act and Other Statutes

1. The Copyright Act

A cause of action for false endorsement under Section 43(a) based on a claim of ownership to Marilyn Monroe's persona-based rights led to an opinion addressing the proper relationship between that section and the Copyright Act. ²⁶⁸⁵ Seeking to defeat the counterclaim plaintiffs' challenge to their sale of T-shirts and other goods bearing images of Monroe, the counterclaim defendants proffered copyrights to "certain Monroe-related artwork," which they argued entitled them to use her image. ²⁶⁸⁶ Describing the copyrights as having "limited utility," ²⁶⁸⁷ the court denied the counterclaim defendants' motion for summary judgment on the issue. It doing so, it corrected what it saw as the motion's mischaracterization of the counterclaim plaintiffs' cause of action, observing, "[a]t bottom, the [counterclaim plaintiffs] argue that the [counterclaim defendants] have made illicit use of Marilyn Monroe's persona, and not any fixed depiction of her. Copyright law provides no protection for the [counterclaim defendants] on this argument." ²⁶⁸⁸

2. The Bankruptcy Code

When a company reorganizes under Chapter 11 of the Bankruptcy Code, Section 365(a) of the Code generally allows either the trustee or the debtor-in-possession to pursue court permission

²⁶⁸³ *Id.* at 932.

²⁶⁸⁴ *Id.*

²⁶⁸⁵ *See* A.V.E.L.A., Inc. v. Estate of Marilyn Monroe, LLC, 364 F. Supp. 3d 291 (S.D.N.Y. 2019).

²⁶⁸⁶ *Id.* at 321.

²⁶⁸⁷ *Id.*

²⁶⁸⁸ *Id.*

to reject executory contracts into which it has entered.²⁶⁸⁹ The ability to reject such a contract is not equivalent to an ability to rescind or revoke it; rather, it merely gives the debtor the choice of assuming the contract or breaching it. Therefore, if rejection occurs, the non-debtor will have a pre-petition claim for the recovery of expectation damages, in connection with which it can receive a distribution through the usual claims allowance process, but the non-debtor ordinarily is not eligible for the equitable remedy of specific performance. Under Section 365(n)(1) of the Code, however, an exception to the last of these propositions applies if the rejected contract is one “under which the debtor is a licensor of a right to intellectual property,” in which case the licensee may elect to “retain its rights . . . to such intellectual property,” thereby requiring the debtor to continue licensing the property in question.²⁶⁹⁰

The definition of “intellectual property” set forth in Section 101(35A) of the Code²⁶⁹¹ does not include trademark rights, however, which led the Supreme Court to address the question of whether the rejection of an executory contract comprising a trademark license by a bankrupt debtor that issued the license necessarily terminates the licensee’s right to continue using the licensed mark. Under Seventh Circuit law, the answer was yes,²⁶⁹² but the First Circuit’s contrary conclusion created a split in the circuits that attracted the Court’s attention.²⁶⁹³ A determination of the proper resolution of that inter-Circuit split was complicated by a number of issues, including a deliberate decision by Congress in 1988 not to provide an answer as a matter of statutory law, the question of whether a licensor’s duty to exercise control over the quality of the goods or services provided under the licensed mark arises as a matter of contract law from the license itself or independently under trademark law, and the nature and extent of remedies available to a nonbreaching licensee outside the bankruptcy context.

The Court ruled in favor of the licensee (and the Seventh Circuit approach to the issue). As the Court observed, a breach by the licensor would not ordinarily lead to a termination of the licensee’s right to use the mark outside of a bankruptcy proceeding. It drove this point home using the following comparison:

A dealer leases a photocopier to a law firm, while agreeing to service it every month; in exchange, the firm commits to pay a monthly fee. During the lease term, the dealer decides to

²⁶⁸⁹ 11 U.S.C. § 365(a) (2018).

²⁶⁹⁰ *Id.* § 365(n)(1).

²⁶⁹¹ *Id.* § 101(35A).

²⁶⁹² See *Sunbeam Prods., Inc. v. Chi. Am. Mfg., LLC*, 686 F.3d 372, 377 (7th Cir. 2012).

²⁶⁹³ See *In re Tempnology, LLC*, 879 F.3d 389 (1st Cir. 2018), *rev’d sub nom.* *Mission Prod. Holdings, Inc. v. Tempnology, LLC*, 139 S. Ct. 1652 (2019).

stop servicing the machine, thus breaching the agreement in a material way. The law firm now has a choice (assuming no special contract term or state law). The firm can keep up its side of the bargain, continuing to pay for use of the copier, while suing the dealer for damages from the service breach. Or the firm can call the whole deal off, halting its own payments and returning the copier, while suing for any damages incurred. But to repeat: The choice to terminate the agreement and send back the copier is for the *law firm*. By contrast, the *dealer* has no ability, based on its own breach, to terminate the agreement. Or otherwise said, the dealer cannot get back the copier just by refusing to show up for a service appointment. The contract gave the law firm continuing rights in the copier, which the dealer cannot unilaterally revoke.²⁶⁹⁴

Thus, “because rejection ‘constitutes a breach’ [under Section 365(g) of the Bankruptcy Code], . . . [t]he debtor can stop performing its remaining obligations under the agreement. But the debtor cannot rescind the license already conveyed. So the licensee can continue to do whatever the license authorizes.”²⁶⁹⁵

3. The Food, Drug, and Cosmetic Act

The issue of when the Food, Drug, and Cosmetic Act bars causes of action challenging allegedly deceptive promotional claims concerning goods within the FDCA’s scope has long been the subject of judicial attention. In *POM Wonderful LLC v. Coca-Cola Co.*,²⁶⁹⁶ the Supreme Court held that the FDCA does not prevent the use of Section 43(a) by plaintiffs claiming that beverage labels are unlawfully misleading, but the Court left open the decision’s significance to products other than foods and beverages. Although the lower federal courts have had little difficulty applying *POM Wonderful’s* holding in similar cases,²⁶⁹⁷ the limited scope of the Court’s holding (deliberate or otherwise) has opened the door for future litigants to dispute the extent to which *POM Wonderful* applies in other contexts.

One opinion to address the issue came from the Eleventh Circuit in a dispute between competing manufacturers of dietary-

²⁶⁹⁴ *Mission Prod. Holdings, Inc. v. Tempnology, LLC*, 139 S. Ct. 1652, 1662 (2019) (citation omitted).

²⁶⁹⁵ *Id.* at 1662-63.

²⁶⁹⁶ 573 U.S. 102 (2014).

²⁶⁹⁷ *See, e.g., Danone, US, LLC v. Chobani, LLC*, 362 F. Supp. 3d 109, 121 (S.D.N.Y. 2019) (rejecting reliance on FDA regulations of defendant found to have falsely advertised the sugar content of its drinkable yogurt and noting that “[r]egulatory compliance does not automatically negate Lanham Act liability”).

supplement products,²⁶⁹⁸ one of which had accused the other of violating Section 43(a) and the Georgia Uniform Deceptive Trade Practices Act.²⁶⁹⁹ The gravamen of the plaintiff's complaint was that the label used by the defendant was unlawfully misleading in multiple respects.²⁷⁰⁰ According to the plaintiff, the label misrepresented the quantity and source of the protein in each serving of the defendant's product. The plaintiff did not, however, aver that the label was inconsistent with regulations from the FDA implementing the FDCA, and that led the district court to dismiss the plaintiff's complaint for failure to state claims upon which relief could be granted.

The Eleventh Circuit affirmed in part and reversed in part. Declining to disturb the district court's dismissal of the plaintiff's claim under Georgia law, the appellate court held that claim expressly preempted by the FDCA because it purported to "directly or indirectly establish . . . [a] requirement for nutrition labeling of food that is not identical to the requirement[s] of the [FDCA]";²⁷⁰¹ specifically, the court explained, "[the plaintiff's] state-law claim is preempted because it would impose liability for labeling that does not violate the Food, Drug, and Cosmetic Act or the regulations that carry it into effect."²⁷⁰² The court reversed the dismissal of the plaintiff's federal claim, however, which it held was not fatally inconsistent with the FDCA for two reasons: (1) the defendant could both comply with the FDA's requirements and include the clarifying information the plaintiff alleged was necessary to prevent deception;²⁷⁰³ and (2) the plaintiff's cause of action did not ask the district court to circumvent the FDA's authority by finding the defendant's labeling failed to comply with the FDCA despite the agency's conclusion to the opposite effect.²⁷⁰⁴

The preemptive effect of the FDCA also disposed of a claim of unfair competition under Pennsylvania common law.²⁷⁰⁵ The case focused on the provenance of water sold by the defendants, which FDA regulations considered "spring water," but which Pennsylvania law considered "well water."²⁷⁰⁶ The court agreed with the defendants that the plaintiff's state law claim challenging the defendants' promotion of their water as having come from a spring depended on the adoption of a standard at odds with that of the

²⁶⁹⁸ See *Hi-Tech Pharm., Inc. v. HBS Int'l Corp.*, 910 F.3d 1186 (11th Cir. 2018).

²⁶⁹⁹ Ga. Code Ann. § 10-1-372(a).

²⁷⁰⁰ *Hi-Tech Pharm.*, 910 F.3d at 1189.

²⁷⁰¹ *Id.* at 1195 (quoting 15 U.S.C. § 343-1(a)(4) (2018)).

²⁷⁰² *Id.*

²⁷⁰³ *Id.* at 1198-99.

²⁷⁰⁴ *Id.* at 1199.

²⁷⁰⁵ See *Frompovicz v. Niagara Bottling, LLC*, 337 F. Supp. 3d 498 (E.D. Pa. 2018).

²⁷⁰⁶ *Id.* at 512.

FDA, and it therefore granted their motion to dismiss that claim. As it explained, “[t]o the degree that Plaintiff’s unfair competition claim is premised on Pennsylvania’s permitting requirements as to what constitutes ‘spring water’ differing from the FDA’s labeling requirements as to what constitutes ‘spring water,’ that claim is preempted”²⁷⁰⁷ It then reached the same conclusion with respect to another theory asserted by the plaintiff, namely, that the defendants’ water did not qualify as spring water under the FDA’s definition of that beverage: “The upshot is that Plaintiff’s ‘generic state law claim’ for unfair competition ‘would not be actionable absent a violation of the FDCA standard. Because Plaintiff’s claim ‘would not exist but for a FDCA regulation, [the FDCA] impliedly preempts the claim.’”²⁷⁰⁸

In a case not raising the specter of preemption, the Federal Circuit also had the opportunity to address the relationship between the Lanham Act and the FDCA.²⁷⁰⁹ It did so in an appeal from a decision by the International Trade Commission not to institute an investigation based on the complaint of a pharmaceutical company that certain of its competitors promoted their products as “dietary supplements,” when, in fact, those products were unapproved new drugs. According to the complaint, the competitors’ use of that terminology violated Section 337 of the Tariff Act²⁷¹⁰ because it violated Section 43(a)’s prohibition against false advertising. Surveying post-*POM Wonderful* jurisprudence on the subject, the court observed (with considerable understatement) that “[g]iven the lack of a private right to enforce the FDCA, other circuit courts have grappled with the extent to which private parties’ claims under § 43(a) of the Lanham Act are limited by the FDCA.”²⁷¹¹ Nevertheless, it resolved the appeal before it in short order by affirming the ITC’s decision not to initiate a proceeding because “[i]n our case, the alleged violations of § 337 are based entirely on—and could not exist without—the FDCA.”²⁷¹² Targeting the complainant’s reliance on *POM Wonderful*, the court observed:

Although *POM Wonderful* held that the FDCA does not categorically preclude a Lanham Act claim based on a product (e.g., a label) that is regulated by the FDCA, the court did not open the door to Lanham Act claims that are based on proving FDCA violations. The allegations

²⁷⁰⁷ *Id.*

²⁷⁰⁸ *Id.* at 513 (quoting *Patane v. Nestle Waters N. Am., Inc.*, 314 F. Supp. 3d 375, 386-87 (D. Conn. 2018)).

²⁷⁰⁹ See *Amarin Pharma, Inc. v. Int’l Trade Comm’n*, 923 F.3d 959, 967 (Fed. Cir. 2019).

²⁷¹⁰ 19 U.S.C. § 1337(a)(1)(A) (2018).

²⁷¹¹ *Amarin Pharma*, 923 F.3d at 966.

²⁷¹² *Id.* at 967.

underlying the Lanham Act claim in *POM Wonderful* did not require proving a violation of the FDCA itself.²⁷¹³

The ITC therefore did not err in declining to pursue the matter.

Finally, and in contrast, an Illinois federal district court directly asserted its jurisdiction over a Section 43(a) cause of action for false advertising, holding that “[c]ourts can evaluate Lanham Act claims that do not require specialized knowledge or interpretation of the FDCA’s requirements.”²⁷¹⁴ It did so while denying a motion to dismiss a challenge to the allegedly false representation on the lead defendant’s labels that its product was “indicated for the introduction of local (topical) anesthesia of accessible mucous membranes of the oral, laryngeal and nasal cavities.”²⁷¹⁵ Citing favorably to an FDA publication providing that a “topical” route was “[a]dministration to a particular spot on the outer surface of the body,”²⁷¹⁶ the court held that “[t]aking [the plaintiff’s] allegations as true for the purposes of this motion, the inside of the nose, mouth, and larynx are not ‘particular spots on the outer surface of the body’ and [the product’s] route of administration cannot accurately be described as ‘topical’ under the FDA’s definitions.”²⁷¹⁷ Dismissal was inappropriate because “[i]t takes no special expertise to determine that the inside of the nose, mouth, and larynx are not on the outside of the body.”²⁷¹⁸

4. The Federal Trade Commission Act

The most notable opinion to address the potential intersection of trademark law and antitrust law came not from a court but instead from the Federal Trade Commission (“FTC”).²⁷¹⁹ Unusually, that agency not only initiated an investigation into long-since resolved trademark disputes, it concluded that the plaintiff had engaged in an actionable conspiracy to restrain trade in violation of Section 1 of the Sherman Act.²⁷²⁰ The underlying actions arose from 1-800 Contacts’ objections to the purchase of its flagship mark as a trigger for paid online advertising, which led it to file trademark infringement actions against a number of its competitors. 1-800

²⁷¹³ *Id.* at 968.

²⁷¹⁴ *See, e.g.,* Genus Lifesciences Inc. v. Lannett Co., 378 F. Supp. 3d 823, 833 (N.D. Cal.) (holding, without extended discussion, that (quoting *Belcher Pharm., LLC v. Hospira, Inc.*, No. 17-cv-2353, 2018 WL 4643292, at *4 (M.D. Fla. Apr. 9, 2018)), *reconsideration denied*, No. 18-CV-07603-WHO, 2019 WL 4168958 (N.D. Cal. Sept. 3, 2019).

²⁷¹⁵ *Id.* at 836.

²⁷¹⁶ *Id.* (alteration in original).

²⁷¹⁷ *Id.*

²⁷¹⁸ *Id.*

²⁷¹⁹ *See In re 1-800 Contacts, Inc.*, No. 9372, 2018 WL 6078349 (F.T.C. Nov. 14, 2018), *appeal docketed*, No. 18-3848 (2d Cir. Dec. 18, 2018).

²⁷²⁰ 15 U.S.C. § 1 (2018).

Contacts lost one of those actions on summary judgment;²⁷²¹ the remaining ones were settled through joint agreements with the defendants, pursuant to which the parties agreed not to bid on their respective marks as keywords. In a lengthy main opinion, accompanied by additional ones by individual commissioners, the FTC found that the settlement agreement violated Section 1 of the Sherman Act²⁷²² and therefore Section 5 of the FTC Act²⁷²³ as well:

We find that the agreements harm consumers and competition for the online sale of contact lenses. We also find that Respondent has not demonstrated valid offsetting procompetitive justifications for the advertising restraints, and that the restraints were not reasonably necessary to achieve the claimed procompetitive benefits. Consequently, we enter a cease-and-desist order that prohibits 1-800 Contacts from enforcing the unlawful provisions in the challenged agreements and prevents 1-800 Contacts from entering into similar agreements in the future. We also find that challenged agreements harm competition in bidding for search engine key words, artificially reducing the prices that Respondent paid and the quality of the search engine results delivered to consumers—without offsetting efficiencies.²⁷²⁴

FTC action came into play in another context as well. If compliance with FDA regulations will not necessarily immunize a producer of food and beverages against false-advertising-based challenges to its packaging, what about compliance with FTC guidelines? One court addressing that question held that a defendant accused of misrepresenting the sugar content of its drinkable yogurt could not escape liability for false advertising by invoking an FTC policy statement addressing “absolute nutrient content claims.”²⁷²⁵ The court identified two rationales for its holding, the first of which was that “this is a Lanham Act case, not an agency enforcement action. Regulatory compliance does not automatically negate Lanham Act liability.”²⁷²⁶ The second was that “[the defendant] has not persuaded the Court that it is complying with the relevant regulations.”²⁷²⁷

²⁷²¹ See *1-800 Contacts, Inc. v. Lens.com, Inc.*, 722 F.3d 1229 (10th Cir. 2013).

²⁷²² 15 U.S.C. § 1.

²⁷²³ *Id.* § 45.

²⁷²⁴ *1-800 Contacts*, 2018 WL 6078349, at *2.

²⁷²⁵ See *Danone, US, LLC v. Chobani, LLC*, 362 F. Supp. 3d 109 (S.D.N.Y. 2019).

²⁷²⁶ *Id.* at 121.

²⁷²⁷ *Id.*

H. Insurance-Related Issues

1. Opinions Ordering Coverage

The issue of whether advertising injury clauses obligate the carriers issuing the policies containing the clauses to cover the defense of allegations of trade dress infringement has long vexed courts, but reported opinions addressing it have been relatively rare in recent years. Nevertheless, an exception to that general trend came in an appeal to the Second Circuit concerning a policy governed by New York law.²⁷²⁸ The court justifiably described the salient clauses of the policy as “convoluted” because, taken together, they provided that: (1) “personal and advertising injury” included the “offense” of “infringing upon another’s copyright, trade dress or slogan in [an] ‘advertisement’”;²⁷²⁹ but (2) advertising injuries arising from “trademark . . . and other intellectual property rights” were expressly excluded;²⁷³⁰ but again (3) the exclusion was subject to another exclusion providing that the first exclusion “this exclusion does not apply to infringement, in your ‘advertisement’, of copyright, trade dress or slogan.”²⁷³¹ The court offered the following summary of the dovetailing clauses in the policy:

The[e] secondary exclusion from the primary exclusion was apparently inserted to make clear that the primary exclusion does not exclude coverage for trade dress infringement in an advertisement

As a result, [the carrier] does not cover claims that a product or the packaging of a product sold by [the insured] infringes on the trade dress of another company’s product but does cover claims that [an] . . . advertisement containing a photo or drawing of [the insured’s] product infringes the trade dress of another company’s product.²⁷³²

Noting that New York law allowed the carrier to “deny its insured a defense ‘only if it could be concluded as a matter of law that there is no possible factual or legal basis on which the insurer might eventually be held to be obligated to indemnify the insured under any provision of the insurance policy,’”²⁷³³ the court affirmed the district court’s entry of summary judgment in the insured’s favor. It did so based on the appearance of the insured’s shoes in advertisements such as the following:

²⁷²⁸ See *High Point Design, LLC v. LM Ins. Corp.*, 911 F.3d 89 (2d Cir. 2018).

²⁷²⁹ *Id.* at 94.

²⁷³⁰ *Id.*

²⁷³¹ *Id.*

²⁷³² *Id.* (footnote omitted).

²⁷³³ *Id.* at 95 (quoting *Servidone Constr. Corp. v. Sec. Ins. Co. of Hartford*, 477 N.E.2d 441, 444 (N.Y. 1985)).

gifts for mom
 you spend \$50 or more on clothing.

40-50% off
 Handbags and collies
 Reg. 12.00-18.00 sale 11.00-16.00

303930
 303991

303995
 303994

\$11.99 sale
 Bracelets Reg. 15.00

\$14.00 sale
 Pendants Reg. 20.00

40% off
 Spring hats and tunics
 Reg. 6.00-20.00 sale 3.60-14.00
 30-40% off tops or accessories

303992
 303990

2-10.99 sale
 Colorful fuzzy beanie slippers
 Reg. 15.00 sale

40% off
 All sunglasses
 Reg. 35.00-75.00 sale 21.00-45.00

30% off
 All flip flops
 Reg. 10.00-15.00 sale 7.00-10.50

SHOP YOUR WAY REWARDS
 EARN REWARDS & FREE
 BOXED CHALK BOARD MUG
 FOR EACH WHEN YOU
 SPEND \$50 OR MORE

As it explained, “[d]isplaying the infringing trade dress in an advertisement is an advertising injury for which damages can be awarded where, as here, it is a means by which the alleged infringer creates customer confusion and trades on the offended party’s goodwill and protected designs.”²⁷³⁴ Nevertheless, although otherwise affirming the district court’s order mandating coverage, the court held that the duty to cover had arisen only when discovery served by the plaintiff in the underlying litigation had made the nature of its claims apparent to the carrier.²⁷³⁵

An even more pro-insured opinion emanated from the Supreme Judicial Court of Massachusetts.²⁷³⁶ The policy in question covered the defense of challenges to the “[t]he use of another’s advertising idea in your ‘advertisement,’” but did not define “advertising idea.”²⁷³⁷ The absence of such a definition came into play when the insured, a shoe manufacturer, sold a five-toed shoe under the BIKILA mark, which led to a challenge by the heirs of long-distance Ethiopian runner Abebe Bikila, who famously won the 1960 Olympic marathon while running barefoot. Their complaint against

²⁷³⁴ *Id.* at 96.

²⁷³⁵ *Id.* at 98.

²⁷³⁶ See *Holyoke Mut. Ins. Co. in Salem v. Vibram USA, Inc.*, 106 N.E.3d 572 (Mass. 2018).

²⁷³⁷ *Id.* at 575.

the insured asserted the plaintiffs had, “by their commercial uses, sponsorships and promotion of historical and education events, and multimedia events emphasizing the cultural and athletic legacy of Abebe Bikila, . . . intentionally associated their family name with Abebe Bikila’s barefoot dedication to succeed under any circumstances.”²⁷³⁸ Although not expressly asserting a claim of trademark infringement, they nevertheless accused the insured of violating Bikila’s right of publicity under Washington state law, false designation of origin and unfair competition under Section 43(a), and unjust enrichment.

Before the trial court, the insured successfully argued that the claims in the underlying action were entirely persona-based and therefore did not accuse the insured of misappropriating an advertising idea falling within the scope of its policy. The appellate court disagreed:

[T]he complaint reasonably may be interpreted as claiming that the Bikila family intentionally created a connection between their [sic] family name and Abebe Bikila’s legacy and desirable qualities for purposes of using “Bikila,” and everything it conveyed, to attract customers to their [sic] running-related commercial ventures. In other words, the Bikila family’s advertising idea was using the name Bikila, and the legacy that name conveyed, to attract business to each of their [sic] ventures. Because the allegations in the complaint generally allege that the Bikila family used the Bikila name to advertise and promote their [sic] various running-related ventures, the judge erred in concluding that the Bikila family had not actually used the name Bikila as an advertising idea.²⁷³⁹

Likewise, the court found it “uncontested that [the insured’s] use of ‘Bikila’ to advertise its minimalist . . . running shoes constituted an advertising idea. [The insured] used the name of a legendary barefoot marathon runner for purposes of calling attention to its running shoes that simulated barefoot running.”²⁷⁴⁰ The court therefore reversed the carrier’s victory below and remanded the action with instructions to order coverage.²⁷⁴¹

Another state court of last report—that of Wisconsin—rejected arguments that a knowing-violation exclusion excused a carrier from covering the defense of a lawsuit accusing the carrier’s insured of various trademark-related torts.²⁷⁴² That court applied the standard rule under Wisconsin law that “[u]nless an exclusion

²⁷³⁸ *Id.* (alteration in original).

²⁷³⁹ *Id.* at 580.

²⁷⁴⁰ *Id.* at 579.

²⁷⁴¹ *Id.* at 581.

²⁷⁴² *See* *W. Bend Mut. Ins. Co. v. Ixthus Med. Supply, Inc.*, 923 N.W.2d 550 (Wis. 2019).

knocks out every pleaded claim, leaving no potentially covered advertising-injury claim for which the insured could be liable, the duty to defend remains.”²⁷⁴³ Reviewing the complaint in the underlying action, the court identified “multiple claims that fall within [the policy’s] personal and advertising injury coverage provision and do not require proof that [the insured] acted with knowledge or with intent to violate [the plaintiff’s] rights and inflict injury.”²⁷⁴⁴ Those included the plaintiff’s allegations of likely dilution under Section 43(c) and New York state law, as well as its claim of deceptive trade practices under New York law. Coverage therefore was appropriate because:

Even though the complaint generally asserts [the insured] acted wrongfully and with knowledge that it was defrauding [the plaintiff], [the carrier] is not relieved of its duty to defend because this complaint alleges at least one potentially covered advertising-injury claim, which does not depend on whether [the insured] acted with knowledge that it was violating [the plaintiff’s] rights or with knowledge that it was inflicting advertising injury.²⁷⁴⁵

2. Opinions Declining to Order Coverage

Like that of most other states, California law is slanted toward insureds,²⁷⁴⁶ but that general rule did not result in coverage for an insured found liable for several torts in Texas state court.²⁷⁴⁷ One successful claim advanced by the plaintiff in the underlying case was that the insured had fabricated a letter allegedly from the local Better Business Bureau explaining that complaints against the insured were in reality complaints against the plaintiff but had been misclassified because of the similarities of the marks used by the plaintiff and the insured. There was apparently no dispute that the insured had used the disparaging letter in promoting its business, and the policy in question unambiguously covered the defense of actions arising from any “[o]ral or written publication, in any manner, of material that slanders or libels a person or organization or disparages a person’s or organization’s goods, products or

²⁷⁴³ *Id.* at 561.

²⁷⁴⁴ *Id.*

²⁷⁴⁵ *Id.* at 562.

²⁷⁴⁶ *See, e.g.,* Scottsdale Ins. Co. v. MV Transp., 115 P.3d 460, 466 (Cal. 2005) (“If any facts stated or fairly inferable in the complaint, or otherwise known or discovered by the insurer, suggest a claim potentially covered by the policy, the insurer’s duty to defend arises and is not extinguished until the insurer negates all facts suggesting potential coverage.”).

²⁷⁴⁷ *See* Premier Pools Mgmt. Corp. v. Colony Ins. Co., 328 F. Supp. 3d 1075 (E.D. Cal. 2018), *appeal docketed*, No. 18-16551 (9th Cir. Aug. 16, 2018).

services.”²⁷⁴⁸ Unfortunately, however, the summary judgment record demonstrated the insured had failed to tender a claim for the defense of that allegation, which led the court to conclude that “[the carrier’s] duty to defend was not triggered under any potential disparagement allegations.”²⁷⁴⁹

The insured fared no better with an alternative strategy, which was to argue that the plaintiff’s challenge to the insured’s PREMIER POOLS AND SPAS service mark qualified the underlying action as one for misappropriation of an “advertising idea” owned by the plaintiff, which used the PREMIER POOLS mark. According to the court:

“Premier Pools” is a name, and not an advertising idea. The Court finds that [the plaintiff in the underlying dispute] did not allege that [the insured] stole an advertising idea, e.g., a special computer program designed to track customer preference data. The “use of an advertising idea” Policy coverage provision does not apply.²⁷⁵⁰

Not surprisingly, that holding foreshadowed the insured’s failure to establish a factual dispute under a third theory upon which it relied, namely, that the plaintiff’s challenge to the insured’s service mark qualified the underlying action as one alleging use of an infringing slogan, which the policy’s advertising injury clause clearly reached. According to the insured, “Premier Pools” comprised “both a name and a slogan because it is a brief, attention-getting phrase used in advertising or promotion.”²⁷⁵¹ Once again, the court was unconvinced, and it entered summary judgment in the carrier’s favor under this theory as well. As it explained, the complaints in the underlying suit did not expressly allege infringement of slogan. Instead, they alleged “only . . . that Premier Pools is a valuable brand that [the insured] unfairly used. To find [the carrier] had a duty to defend, the Court would have to improperly presume facts not alleged in the complaint.”²⁷⁵²

Finally, the insured fell short in its attempt to invoke the policy’s coverage for the defense of actions for trade dress infringement. As the court summarized this particular claim, “the [complaint] gave [the carrier] notice of a potential trade dress claim because of allegations of consumer confusion based on [the insured’s] use of a ‘Premier Pools’ logo in marketing materials and also because [the insured’s trial counsel] testified that he was prepared to defend a

²⁷⁴⁸ *Id.* at 1079.

²⁷⁴⁹ *Id.* at 1087.

²⁷⁵⁰ *Id.* at 1088.

²⁷⁵¹ *Id.* at 1089.

²⁷⁵² *Id.* at 1090-91.

trade dress infringement claim.”²⁷⁵³ That theory, the court held, was an insufficient basis for coverage: “[The complaint] did not contain potential trade dress allegations or facts giving rise to such claims. [The plaintiff] made no allegations that [the insured] copied its designs and so [the carrier] was not on notice that a trade dress claim was possible.”²⁷⁵⁴ Summary judgment in the carrier’s favor therefore was appropriate on that basis as well.

A second application of California law failed to mandate coverage for another pair of insureds alleged to have violated a consent injunction in the underlying action that prohibited them from disparaging the plaintiff.²⁷⁵⁵ The court granted the carrier’s motion for summary judgment on two grounds, the first of which was that the plaintiff sought only an award of its attorneys’ fees as a sanction, rather than the “damages” required to trigger the policy.²⁷⁵⁶ The second was the presence in the insured’s policy of disclaimers excluding coverage for “any claim or suit” arising of “any actual, alleged, or threatened misappropriation, infringement, or violation of any intellectual property or intellectual property right or law of any description” or out of “any actual, alleged, or threatened violation of any statutes, common law, of other laws or regulations concerning unfair competition, . . . trade, piracy, unfair trade practices, or any similar laws or regulations.”²⁷⁵⁷ Invoking those exclusions, the carrier successfully argued that they barred coverage because the allegations in the underlying suit swept in claims under the Lanham Act: “The Court agrees with [the carrier] that these exclusions bar coverage of the *entire* [underlying suit], including the Contempt Proceeding. Importantly, the exclusions apply not just to ‘any claim,’ but also to any ‘*suit*’ that includes intellectual property or unfair competition claims.”²⁷⁵⁸

Similar language in an exclusion produced a similar outcome in an application of New York law.²⁷⁵⁹ That language excluded coverage both for “any actual or alleged infringement or violation of any intellectual property right” and “[a]ny injury or damage alleged

²⁷⁵³ *Id.* at 1091.

²⁷⁵⁴ *Id.*

²⁷⁵⁵ *See* Great Am. E & S Ins. Co. v. Theos Med. Sys., Inc., 357 F. Supp. 3d 953 (N.D. Cal. 2019), *appeal docketed*, No. 19-15351 (9th Cir. Feb. 28, 2019).

²⁷⁵⁶ According to the court’s holding on this point:

Under California law, attorneys’ fees do not constitute covered “damages.” Sanctions also do not constitute “damages.” Therefore, the Court agrees with [the carrier] that to the extent [the plaintiff] only sought attorneys’ fees and sanctions, those claims do not constitute a claim for “damages” that is covered by the policies.

Id. at 967 (citations omitted).

²⁷⁵⁷ *Id.* at 969-70.

²⁷⁵⁸ *Id.* at 970.

²⁷⁵⁹ *See* Lepore v. Hartford Fire Ins. Co., 374 F. Supp. 3d 334 (S.D.N.Y. 2019).

in any claim or ‘suit’ that also alleges an infringement or violation of any intellectual property right, . . . regardless of whether this insurance would otherwise apply.”²⁷⁶⁰ It came into play after the filing of an underlying action accusing the insured of a variety of torts, “among them breach of contract, tortious interference with advantageous business relationships, common law unfair competition, breach of fiduciary duty, breach of the covenant of good faith and fair dealing, and unjust enrichment.”²⁷⁶¹ The insured argued that the exclusion’s reference to “common law unfair competition” did not capture trademark infringement, but the complaint in the underlying action averred the insured’s actions “either have caused the public to be confused, or are likely to cause the public to mistakenly believe, that Defendants are authorized to sell products bearing the [Plaintiff’s marks].”²⁷⁶² Based on that averment, the court held on the parties’ cross-motions for summary judgment that “[t]his Court need not decide whether *any* claim of unfair competition would bring a suit within the IP Exclusion, because these allegations state a claim for violation of intellectual property rights.”²⁷⁶³ An application of Florida law to the same general scenario also yielded a victory for a carrier on cross-motions for summary judgment.²⁷⁶⁴ The plaintiff in the underlying case was a franchisor that sued the insureds for infringement, unfair competition, and breach of contract, after the insureds continued using the plaintiff’s marks following their termination as franchisees. Those allegations brought the case squarely within the scope of exclusions covering the defense of suits “[a]rising out of a breach of contract” and “[a]rising out of the infringement of copyright, patent, trademark, trade secret or other intellectual property right.”²⁷⁶⁵ Arguing that the plaintiff’s cause of action for unfair competition alleged a tort potentially not triggering the first exclusion, the insureds attempted to call the court’s attention to a summary judgment omnibus order in the underlying case, but the court declined to consider the order because it was outside the four corners of the complaint.²⁷⁶⁶ And, after reviewing that document, the court concluded that [the plaintiff’s] unfair competition claim is not broader than an infringement-related claim.”²⁷⁶⁷ Moreover, “no matter which legal theory [the plaintiff] proceeded under, each

²⁷⁶⁰ *Id.* at 340.

²⁷⁶¹ *Id.*

²⁷⁶² *Id.* at 346.

²⁷⁶³ *Id.*

²⁷⁶⁴ *See* Starr Indem. & Liab. Co. v. Miami Chocolates, LLC, 337 F. Supp. 3d 1216 (S.D. Fla. 2018), *appeal dismissed*, No. 18-14035-HH, 2018 WL 9779593 (11th Cir. Dec. 18, 2018).

²⁷⁶⁵ *Id.* at 1220.

²⁷⁶⁶ *Id.* at 1223.

²⁷⁶⁷ *Id.* at 1225.

claim—including its unfair competition claim—was ultimately based on conduct that arose out of [the insureds'] breach of the Agreement. As a result, the Breach Exclusion also applies to each of [the plaintiff's] underlying claims."²⁷⁶⁸

A final reported opinion declining to order coverage came in an application of Idaho law by the supreme court of that state.²⁷⁶⁹ The issue presented for the court's consideration was a fairly simple one, namely, whether a prior-publication exclusion rendered the insured's claim for coverage moot. In affirming the carrier's victory on summary judgment below, the court held that "[s]o long as there exists a genuine dispute over facts bearing on coverage under the policy or over the application of the policy's language to the facts, the insurer has a duty to defend."²⁷⁷⁰ In the case at hand, however, no such dispute existed; instead, the complaint in the underlying action clearly accused the insured of having infringed its mark a month before coverage under the policy began based on the mark's appearance on the Facebook page of the insured's soon-to-open restaurant. The insured argued it had not done business under the accused mark until after the policy took effect, but the court held that:

Plainly read, the exclusion clearly indicates that if an injury arises after coverage is purchased, it will not be covered if the material was published prior to coverage. The "arising out of" language necessitates a causal connection with the later advertising injury, but so long as that connection exists the prior publication exclusion excludes coverage.²⁷⁷¹

The court then rejected the insured's backup argument that, because the insured had introduced goods bearing the mark following the policy's effective date, sales of those goods constituted "fresh wrongs" triggering coverage. As it explained, "[a]dvertising [an allegedly infringing mark] in connection with a restaurant about to open and thereafter placing an almost identical [mark] on glassware, clothing, beer and ale, and Facebook creates substantially similar wrongs."²⁷⁷² The policy therefore did not obligate the carrier to defend the underlying action.

²⁷⁶⁸ *Id.* at 1226.

²⁷⁶⁹ *See* *Scout, LLC v. Truck Ins. Exch.*, 434 P.3d 197 (Idaho 2019).

²⁷⁷⁰ *Id.* at 203.

²⁷⁷¹ *Id.* at 204-05.

²⁷⁷² *Id.* at 208.

GUIDELINES FOR SUBMITTING A MANUSCRIPT TO *THE TRADEMARK REPORTER*

The Trademark Reporter (TMR) invites all submissions that concern trademark law and related topics under U.S. and international law, including articles, commentaries, and book reviews. Submissions may be sent via email to tmr@inta.org.

Please see the TMR Style and Submission Guide at <https://www.inta.org/TMR/Pages/StyleGuide.aspx>.

THE TRADEMARK REPORTER ONLINE

International Trademark Association: Issues of *The Trademark Reporter* beginning with Volume 105, Number 1, 2015, are available to the public at <https://www.inta.org/TMR>. All issues are available to INTA members free of charge at <https://www.inta.org/TMR>.

HeinOnline: Issues of *The Trademark Reporter*, beginning with Volume 1, Number 1, 1911, are available through HeinOnline's database service under "Law Journal Library" at <https://www.heinonline.org>.

LexisNexis: Issues of *The Trademark Reporter*, beginning with Volume 31, Number 1, 1941, are available through the LexisNexis database service under "Law Reviews & Journals" at <https://www.lexis.com>.

Westlaw: Issues of *The Trademark Reporter*, beginning with Volume 80, Number 1, 1990, are available through the Westlaw database service under "Treatises & Other Materials" at <https://www.westlaw.com>.

PRINTED COPIES

Printed copies of *The Trademark Reporter* can be ordered from William S. Hein & Co., Inc. (order@wshein.com).