

FIREQUIP HYDRANT LANDING VALVE

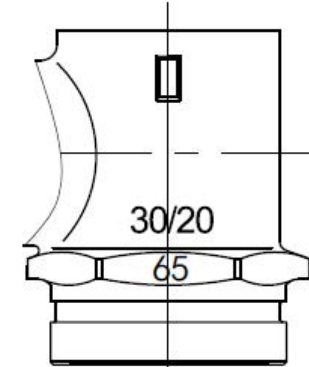

ITEM	DRAWING NUMBER	NAME	QTY	MATERIAL	REMARK
1	J280 C9-fm1-01	Body	1	C83600	
2	J280-fm1-0	Nut	1	QuZn36Pb2As	
3	J280 C-fm1-03	Washer	1	NBR (A80° ± 5°)	N3578.80 Ø70xØ12.9x5
4	J280 C-fm1-04	Seat	1	QuZn36Pb2As	
5	J280 C-fm1-05	Spindle	1	QuZn36Pb2As	
6	J280 C-fm1-06	Cover	1	C83600	
7	O-72x1.8-NBR	O-Ring	1	NBR	Ø72 xØ1.8
8	O-18.5x355-NBR	O-Ring	1	NBR	Ø18.5 xØ3.55
9	J280A-fm1-07	Cover Nut	1	C37700	
10	J280-fm1-09	Wheel Handle	1	QT400-18	
11	DP-23x8.2.2x2-304	Washer	1	S 304	Ø23 x8.2 x2
12	LD-5/16x12.5-304	Hex Bolt (S14)	1	S 304	5/16x12.5
13	J280 C-fm1-13B	Aluminum Joint	1	Parts Assembly	
14	CV-221-05.03	Cap	1	POM	Red
15	CV-221-05.04	Chain	1	Q235A	L36

Working Pressure: 1400kPa
 Test Pressure 2700kpa
 Temperature Rating -10°~85°

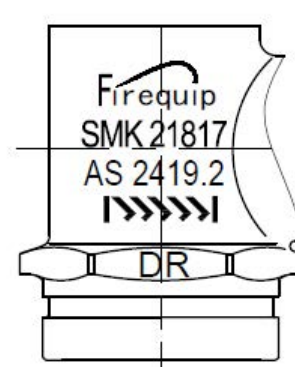
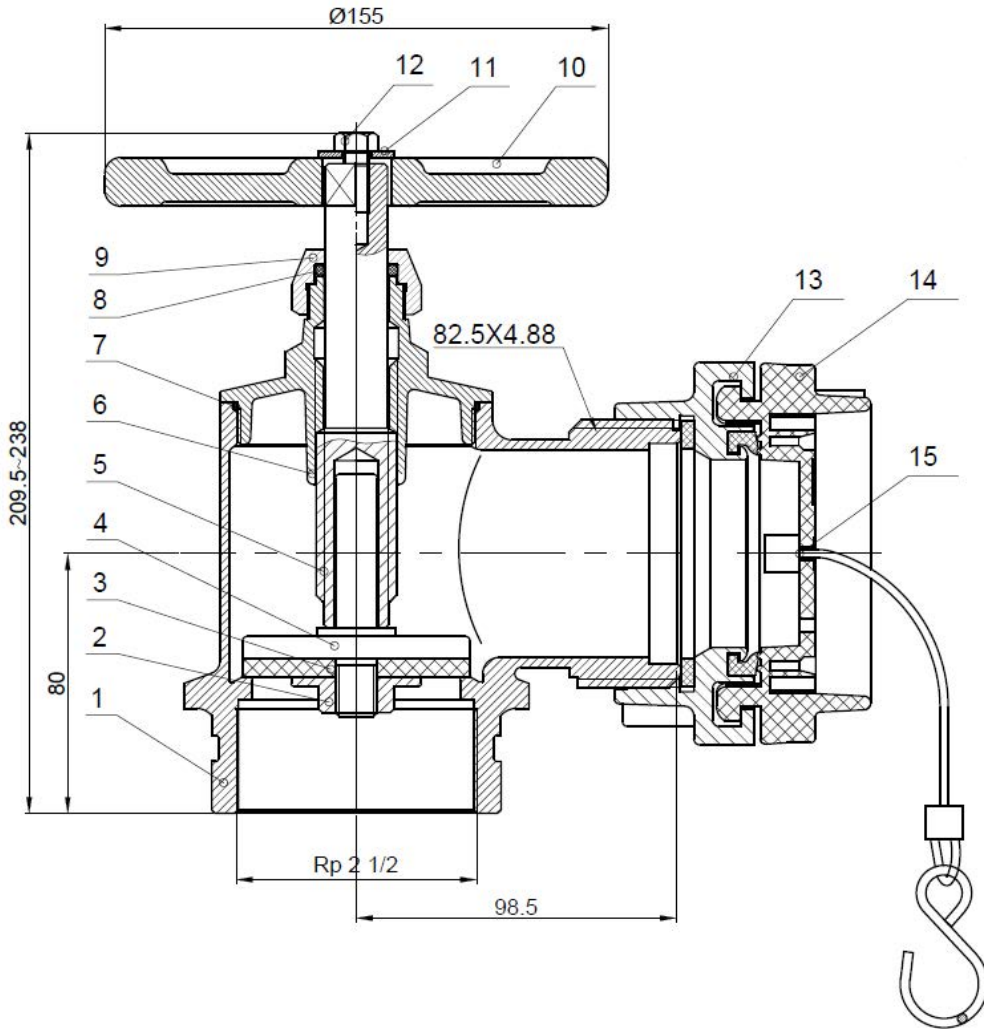

AS2419.2
 CERTIFICATE NUMBER SMK21817