

TECHNICAL SPECIFICATIONS

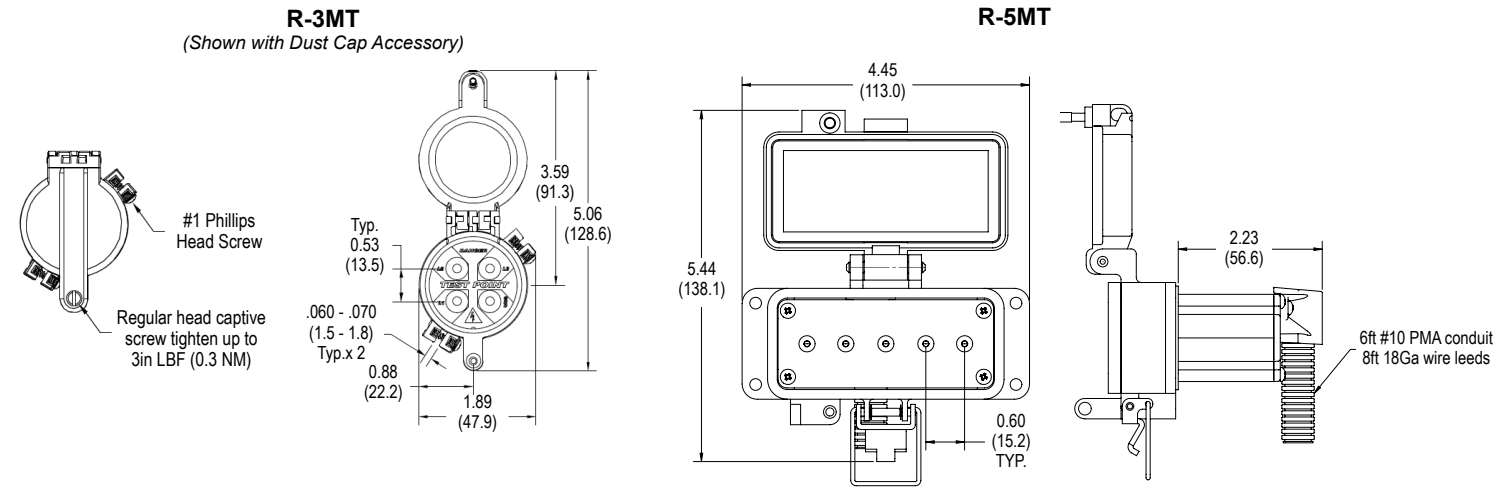

For more details on each product please refer to the installation guide(s).

FREQUENTLY ASKED QUESTIONS

Q: What is the shock hazard when using this device?

A: This high impedance device limits the max. available fault current to 2.94mA at 600V and 2.35mA at 480V when any two test point jacks are shorted together. According to OSHA document 3075 (2002) page 7, "any shock hazard under 6mA is considered a slight shock; uncomfortable, but not painful."

Q: How do I perform a "live-dead-live" test with the 3-MT?

A: Always follow lockout/tagout procedures as per Article 120.4 and "live-dead-live" test procedure as per Article 120.5(7) of NFPA 70E (2018)--with a properly rated test instrument, verify the test instrument to a known source, then insert the test probes into the R-3MT test point assembly to verify the presence of voltage. Next, open the isolator and proceed to verify the absence of voltage on the R-3MT assembly by measuring L1-L2, L1-L3, L2-L3, L1-G, L2-G and L3-G. Once you have verified voltage absence, re-verify the test instrument to a known source.

Q: What would a typical Lockout/Tagout (LOTO) procedure include with this device?

A: Follow NFPA 70E Article 120.5, Process for establishing and verifying an electrically safe work condition. The Safe-Test Point™ allows voltage measurements from phase to phase and phase to ground to check for absence of voltage safely from outside the enclosure.

Q: Where do I install the Safe-Test Point™ on my equipment?

A: Safe-Test Point™ can be directly wired to either the load side or line side of the LOTO voltage source point. It can also be directly wired onto the bus below the fuses to measure a blown fuse or a tripped circuit breaker.

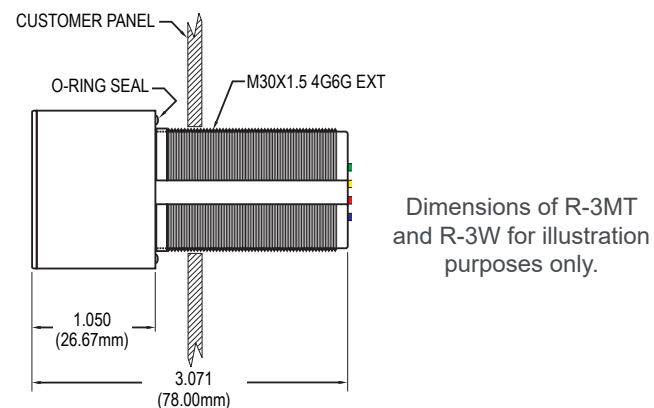

Dimensions of R-3MT and R-3W for illustration purposes only.

For a complete listing of Frequently Asked Questions please scan the QR Code to the left to go to our Knowledge Base.

Warning: Verify an electrical conductor has been de-energized using an adequately rated test instrument before working on it. Follow appropriate Energy Control (Lockout/Tagout) procedures as per OSHA Subpart S.

© Grace Engineered Products, Inc. All rights reserved. Specifications are subject to change with/without notice.

SAFE-TEST POINT™

High impedance protected device that allows for a closed-door absence of voltage test



NEW
5-Wire
Safe-Test Point™
now available!

SAFE-TEST POINT™ FEATURES

- ▶ **Safe-Test Point™** is a Permanent Electrical Safety Device (PESD) that allows workers to safely perform an Absence of Voltage Test (AVT) from outside the electrical cabinet with a portable test instrument.
- ▶ The **Safe-Test Point™** contains test point jacks that are hardwired directly to energy sources and allows measurement of both AC and DC voltages by inserting the insulated meter probes into any two test point jacks to take a voltage reading.
- ▶ The 4-Wire option comes complete with a tool-entry dust cap that also includes a label and the 5-Wire option is featured in a pad-lockable housing that also includes tool-entry.
- ▶ Provides a safer and more productive method of performing Lockout/Tagout (LOTO), while enhancing compliance with NFPA 70E and the OSHA energy isolation principle.

FOR MORE INFORMATION VISIT PESD.COM OR CALL 1.800.280.9517



OPERATION



The **Safe-Test Point™** provides voltage test point jacks to allow measurement of AC/DC voltages either phase-to-phase, phase-to-ground, phase-to-neutral, or neutral-to-ground. Following facility safety procedures, insert insulated meter probes with .080" tips into any two test point jacks to take a voltage reading with properly rated test equipment (*see Test Instrument Requirements*). By following proper safety procedures, the risks of arc flash or shock hazard is greatly reduced.

In addition to the 4-Wire testing option, the Safe-Test Point is the first voltage portal from our line of GracePESDs® to feature an optional 5-Wire configuration for use on wye power systems with a neutral terminal. Mounting options will vary between the 4-Wire and 5-Wire configurations (*refer to the installation guide(s) for more details*).

SAFE-TEST POINT™ TECHNICAL SPECIFICATIONS

	CAT III & IV RATED	
	 R-3MT-KIT-H	 R-5MT
SERIES	4-WIRE SAFE-TEST POINT™	5-WIRE SAFE-TEST POINT™
Product Number	R-3MT-KIT-H* R-3MT-KIT-F*	R-5MT R-5MT-4X R-5MT-12
Descriptions	4-Wire Safe-Test Point™ with label and dust cap	5-Wire Safe-Test Point™
Operating & Storage Temperature	Operate: -20°C to +55°C Storage: -45°C to +85°C	Operate: -20°C to +55°C Storage: -45°C to +85°C
Operational Range AC Single or 3-Phase	0 to 600VAC phase to phase and/or phase to ground 0 - 400HZ	0 to 600V CAT IV, 0 to 1000V CAT III phase to phase and/or phase to ground 0-400 HZ
Operational Range DC or Stored Energy	0 to 1000VDC, any (2) wires line-to-line or line-to-ground (UL Listed to 600VDC)	
Internal Resistance	102 kΩ in series with each input (L1, L2, L3, GND) wire to respective output jack	102 kΩ in series with each input (L1, L2, L3, N, GND) wire to respective output jack
Correction Factor	2% (Voltage measured value reads 2% less than the actual value due to the impedance protection inside the device)	
Wire Specifications	8ft UL Listed 18AWG PVC Insulated	
Components	3 Red jacks (L1, L2, L3), 1 Green jack (GND), .080" DIA pin sockets, 30mm push button hole, minimum probe insertion length .480"	3 Red jacks (L1, L2, L3), 1 Black jack (Neutral), 1 Green jack (GND), .080" DIA pin sockets, minimum probe insertion length .480"
Certifications	UL Type 12 & 13 File #: E311256; CE**	Port: UL Type 4,4X,12 File #: E311256, E207344; CE





FOR MORE INFORMATION VISIT PESD.COM OR CALL 1.800.280.9517

Warning: Verify an electrical conductor has been de-energized using an adequately rated test instrument before working on it. Follow appropriate Energy Control (Lockout/Tagout) procedures as per OSHA Subpart S.

© Grace Engineered Products, Inc. All rights reserved. Specifications are subject to change with/without notice.



R-3W SERIES VOLTAGE INDICATOR AND SAFE-TEST POINT™ COMBO TECHNICAL SPECIFICATIONS

	CAT III & IV RATED			
	 R-3WMT-LMH	 R-3W2MT-LMF	 R-3WSMT-LMH	 R-3WAMT-LMF
Product Number	R-3WMT-LMH* R-3WMT-LMF*	R-3W2MT-LMH* R-3W2MT-LMF*	R-3WSMT-LMH* R-3WSMT-LMF*	R-3WAMT-LMH* R-3WAMT-LMF*
Voltage Indicator	R-3W (Flashing red LEDs)	R-3W2 (Flashing red LEDs)	R-3W-SR (Non-flashing red LEDs)	R-3WA-RA (Flashing amber ground LEDs)
Label Dimensions	Horizontal - 4.323"H x 6.50"W		Flange - 10.058"H x 1.90"W	
Operating & Storage Temperature	Operate: -20°C to +55°C Storage: -45°C to +85°C			
Operational Range AC Single or 3-Phase	40-600VAC 50/60Hz	40-600VAC 50/60/400Hz	40-600VAC 50/60Hz	40-600VAC 50/60Hz
Operational Range DC or Stored Energy	Voltage Indicators: 30 to 1000VDC Safe-Test Point: 0 to 1000VDC (UL listed to 600VDC)			
Wire Specifications	PVC insulated with nylon jacket, 8ft, 18AWG Wire, 90°C @ 1000V, UL 1452, pre-stripped and tinned			
Certifications**	UL 12 & 13, CE			

Special configurations and custom labels available upon request. Contact your sales representative for more information.

*Part numbers ending in H are horizontal mount units and labels. Part numbers ending in F are flange mount units and labels.

**Dust cap and label are not UL or CE certified.

R-3MT TERMINATIONS

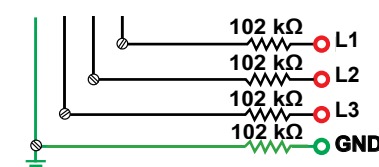

Note: Test Point Assembly with 102 kΩ impedance on L1, L2, L3, and GND affects voltage readings - 2%.

R-5MT TERMINATIONS

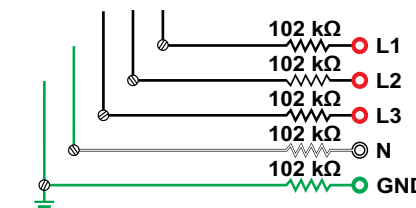

PORTABLE TEST INSTRUMENT REQUIREMENTS

Voltage test instrument with 1000V AC/DC rated input minimum, a typical 10MΩ input impedance and CAT III & IV. A pair of insulated test probes with .080" DIA. points with minimum probe insertion length of .480".

FOR MORE INFORMATION VISIT PESD.COM OR CALL 1.800.280.9517

Warning: Verify an electrical conductor has been de-energized using an adequately rated test instrument before working on it. Follow appropriate Energy Control (Lockout/Tagout) procedures as per OSHA Subpart S.

© Grace Engineered Products, Inc. All rights reserved. Specifications are subject to change with/without notice.

