



FROMMM | AIRPAD
SYSTEMS

AP150 Bubble on demand

- User-friendly
- Compact design
- Roll production or storage

FROMM's compact bubble on demand system



Benefits

- Compact and ergonomic design
- Easy to integrate on any packstation
- High reliability
- Reduces material handling

Specifications

- Built-in or external blower
- Modular configuration
- Wide range of films, up to 800mm | 31.5"

Characteristics

		STD	PRO
Item code	220 V	50.1092	50.1096
	110 V	50.1090	50.1094
Speed (m/min ft/min)		8.0 26.2	8.0 26.2
Weight (kg lbs)		8.8 19.4	8.8+12.0 19.4+26.5
Internal blower for standard inflation pressure		YES	NO
External compressor for high inflation pressure		NO	YES
Units per pallet		24	20
Optional winder		YES ⁽¹⁾	YES ⁽²⁾
Optional stand		STD version	PRO version
Overhead hopper		YES	YES
Compact bin		YES	YES

⁽¹⁾ to be used with external control box (item code 50.2127)

⁽²⁾ to be used with external control box (item code 50.2127) and an ethernet/RJ45 port splitter

AP 150 STD



AP 150 PRO





AP150 accessories

Roll production

Compact stand

- Suitable for both STD and PRO versions
- Use as single stand
- Available with optional winder
- Item code:
AP150 STD: 50.100160
AP150 PRO: 50.100161

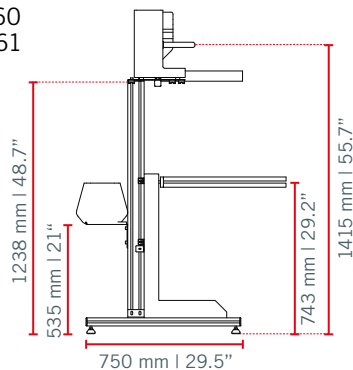

Standalone floor winder

- Easy connection to the machine by aviation cable and control box
- Sensor for automatic stop of winder and machine at the end of the roll
- Item code:
Winder 110V: 50.2122
Winder 220V: 50.2120

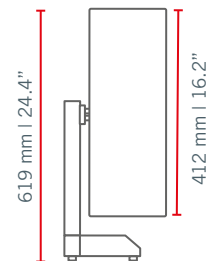

Storage station

Top bin mini

- Versatile for single or multiple packstations
- Various mounting options
- Electric lift for easy film loading
- Adjustable height
- Automatic filling of the bin
- Custom design

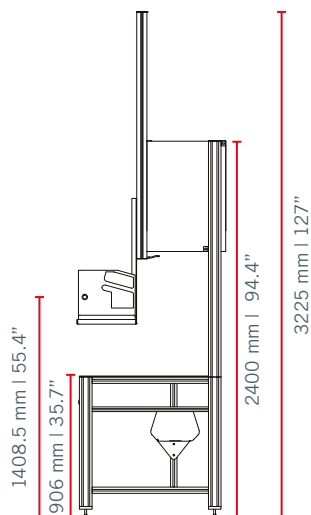

Compact bin

- Simple and compact solution for efficient integration
- Easy to assemble and install
- Universal solution for all packstations
- Ergonomic solution with easily adjustable pad holder
- Item code:
AP150 STD: 50.100450
AP150 PRO: 50.100451

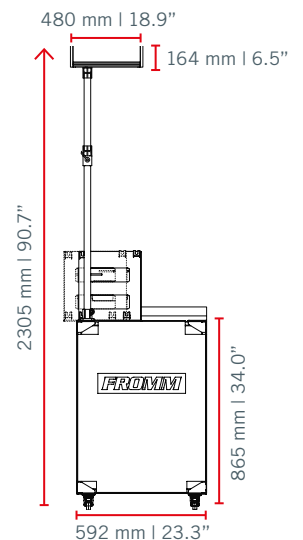



The right solution for your packaging needs

High performance films

- Suitable for bottom and side wrapping
- Suitable for various shapes
- Ensures optimal protection

Product name	Roll width	Roll length	Perf.length	Sealing pattern	Film type	Item code
BBL1 400x300mm 16x12"	400mm 16"	450m 1476'	300mm 12"		 Strong	37.9351
BBL1 400x300mm 16/12"	400mm 16"	450m 1476'	300mm 12"		 Barrier	37.9357
BBL1 600x300mm 24x12"	800mm 24"	220m 722'	300mm 12"		 Barrier	37.9359
BBL1 800x300mm 32x12"	800mm 32"	110m 361'	300mm 12"		 Barrier	37.9360

Tailor-made integration

- FROMM is present at all steps of your project, from identification of needs to installation and full maintenance of the line
- FROMM's end-of-the line expertise ensures reliable solutions, increased productivity and optimum ergonomics



On-time delivery



Optimum working conditions



Profitable equipment



Flexible financing

FROMM PACKAGING SYSTEM CANADA
 UNIT 6, 676 MONARCH AVE,
 AJAX, ON, CANADA
 L1S 4S2
 Tel. +1 905-428-3444
 sales@frommpackaging.ca
 www.frommpackaging.ca

scan this code

A 5-STEP PROCESS

- 1 Needs identification**
Audit questionnaire for accurate description of requirements
- 2 Integration approach**
2D/3D drawings within 2 weeks
Quotation
Lead time
- 3 System manufacturing**
- 4 Installation & commissioning**
- 5 Maintenance & Support**