

ORTAL

YOUR LIFE. YOUR FIRE.

Installation and Operation Manual Wilderness 44H Series

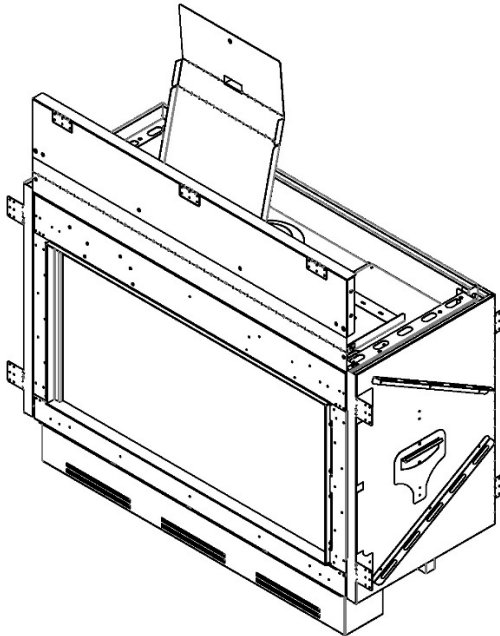
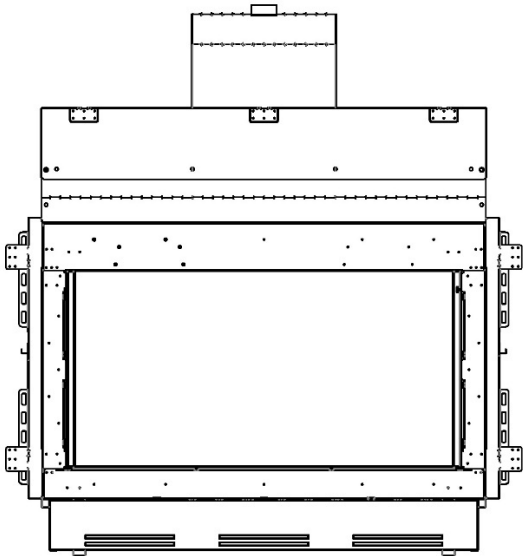

Wilderness 44H Series Fireplaces:

Wilderness 44H Front
Wilderness 44H RS
Wilderness 44H LS
Wilderness 44H TS

⚠ WARNING:

FIRE OR EXPLOSION HAZARD

Failure to follow safety warnings exactly could result in serious injury, death, or property damage

- **DO NOT** store or use gasoline or other flammable vapors and liquids in the vicinity of this or any other appliance.
- **What to do if you smell gas**
 - **DO NOT** try to light any appliance
 - **DO NOT** touch any electrical switch. **DO NOT** use any phone in you building
 - Leave ther building immediately
 - Immediatly call your gas supplier from a neighbor's phone. Follow the gas suppliers's instructions
 - If you cannot reach your gas supplier, call the fire department.
- Installation and service must be performed by a qualified installer, service agency, or the gas supplier.

! DANGER



**HOT GLASS WILL
CAUSE BURNS.**

**DO NOT TOUCH GLASS
UNTIL COOLED**

**NEVER ALLOW CHILDREN
TO TOUCH GLASS.**

A barrier designed to reduce the risk of burns from the hot viewing glass is provided with this appliance and must be installed for the protection of children and other at-risk individuals



General

Safety Information and Warnings

WARNING: REVIEW ALL WARNINGS

Be sure to review all safety warnings and installation guidelines contained in this manual. Consider installation location, vent configuration, clearances, structural requirements, framing and finish materials, and local codes. ALL warnings and instructions apply to all products manufactured and distributed by Ortal.

WARNING: DO NOT OPERATE FIREPLACE IF:

The glass is NOT properly secured in place; Connection points are not sealed (for fireplaces with glass-to-glass connections); Glass is cracked; You smell gas; Any part of the fireplace has been under water; You have any doubt about safe operation of the fireplace; Or if any part has been under water, do not use the fireplace. Immediately call a qualified, professional service technician to inspect the fireplace and to replace any parts of the control system and any gas controls which have been under water.

WARNING: ELECTRICAL GROUNDING

All electrical connections must be properly installed, insulated, and secured to avoid potential **ELECTRICAL SHOCK** and **FIRE HAZARD** and malfunction of the system. Consult local building code requirements. In the absence of local codes, refer to the National Electric Code, ANSI/NFPA 70, or the Canadian Electric Code, CSA C22.1.

WARNING: MATERIAL USAGE

All materials and objects used to carry out the installation must be certified/approved or specified by Ortal and are suitable for use. Do NOT install the system with different materials or objects than those approved for installation by Ortal.

WARNING: INSTALLATION AND SERVICE

Installation and repairs on the fireplace and vent system must be done by an authorized Ortal qualified installer service agency or gas supplier. If these components are not installed by an authorized Ortal dealer/installer, the warranty of all components will be void and Ortal will not be responsible for any damage caused by improper installation. The fireplace should be inspected before use and at least annually by a professional service person. More frequent cleaning may be required due to excessive lint from carpeting, bedding material, etc. Control compartments, burners and circulating air passageways of the fireplace must be kept clean. Any alteration to the product can cause soot or carbon to form and may result in damage. This damage and any other damage that results from not following the instructions outlined in this manual is not the responsibility of Ortal.

WARNING: HEAT BARRIER

A barrier designed to reduce the risk of burns from hot viewing glass is provided with this fireplace and shall be installed. The fireplace **MUST** not be used without the heat barrier in place. If the barrier becomes damaged, the barrier shall be replaced with the manufacturer's barrier for this fireplace. **Any safety screen, guard, or barrier removed for servicing the fireplace must be replaced before operating.**

WARNING: FIREPLACE TEMPERATURE

Due to hot temperatures, the fireplace should be located out of traffic and away from furniture and draperies. Children and adults should be alerted to the hazards of high surface temperature and should stay away to avoid burns or clothing ignition. Clothing or other flammable material should not be placed on or near the fireplace. **Young children should be carefully supervised when they are in the same room as the fireplace.** Toddlers, young children, and others may be susceptible to accidental contact burns. A physical barrier is recommended if there are at-risk individuals in the house. To restrict access to a fireplace or stove, install an adjustable safety gate to keep toddlers, young children, and other at-risk individuals out of the room and away from hot surfaces.

WARNING: GLASS HANDLING

Only an Ortal certified installer is authorized to remove the glass using a suction cup supplied by Ortal.

WARNING: INSTALLATION AND OPERATION

The fireplace and accompanying components must be installed as an OEM installation in manufactured homes (USA only) or an aftermarket permanently located, or a mobile home, where not prohibited by local codes. The fireplace must be installed in accordance with the Manufacturer's instructions and the Manufactured Home Construction and Safety Standard, Title 24 CFR, Part 3280, in the United States, or the Standard for Installation in Mobile Homes, CAN/CSA Z240 MH Series, in Canada. **Exceeding the restrictions imposed in these instructions may result in a fire or explosion, causing property damage, personal injury, or loss of life. Ortal will not be responsible for any damage caused by improper installation. Do not store or use gasoline or other flammable vapors and liquids near this fireplace.**

WARNING: GAS FIREPLACE

This fireplace is for use only with the type of gas indicated on the rating plate. These fireplaces are not convertible for use with other gases unless a certified kit is used, and the conversion is performed by an authorized and qualified technician. Applicable standards are Vented Gas Fireplace Heaters ANSI Z21.88 / CSA 2.33a and Gas-fired Fireplaces for Use at High Altitudes CAN/CGA 2.17-M91

Table of Contents

General	2
Safety Information and Warnings	2
Product Information	4
Certification	4
Models	4
Rating Label	5
Zero-Clearance Stand-Offs	5
Installation	6
Prior to Installation	6
Locate the Fireplace	6
Fireplace Installation	6
First Trip to Site: Planning	6
Second Trip to Site: Installation	6
Third Trip to Site: Startup	7
Post-Installation	7
Initial Burning Period	7
Final Inspection Procedure	7
Final Checks and User Instruction	7
Building Around the Fireplace	8
Building Checklist	8
Framing	9
Framing Dimensions	9
5/8" Type X Drywall Requirements	11
Platform	11
General Clearances	12
Heat Release	14
Air Intake	16
Mounting a TV/Artwork	18
Access Panel	20
Chase Area Minimum	20
Recessed Ledge	21
Structural Weight Support	22
Step-by-Step Chase Construction	23
Finishing	24
Non-Combustible Finish	24
Combustible Finish	26
Combustible Floor/Hearth	28
Venting	29
General Venting Requirements	29
Vent Installation	29
Vent Clearances	30
Offset Maximum	30
Vent Configuration Diagrams	31
Vent Restrictor Sizing Guidelines	32
Restrictors and Vent Configuration	33
Vent Termination	34
Horizontal Termination Clearance Diagram	34
Vertical Termination Clearance Diagram	35
Chimney Shroud	36
Vent Maintenance	36
Gas	37
Gas Pressures	37
Routing the Gas Line	37
Gas Conversion	37
High Altitude Requirements	37
Gas and Electrical Components	38

Electrical	39
Electrical Requirements	39
Pairing the Remote and Receiver	39
Wiring Diagrams	40
Carbon Monoxide Detector Wiring Diagrams	44
Smart Home Wiring Diagram	46
Driftwood Log Set	46
Log Placement	47
Log Base Position Adjustment	53
Adjustment Instructions	54
Operation	58
10-Button Remote Control Handset	58
Wall Switch	59
myFire App	60
Fireplace Maintenance	60
General Maintenance	60
Troubleshooting	61

Product Information

Certification

Wilderness 44H series fireplaces have been tested and approved by CSA Group for safety and efficiency for use with Natural Gas (NG) and Propane (LP) only, and **NOT** for use with solid fuels. **CSA Group is approved by the American National Standards Institute (ANSI) as an Accredited Standards Developer.**

Certification Standard:

US: ANSI Z21.88 – 2016: Vented Gas Fireplace Heaters

Canada: CSA 2.33 – 2016: Vented Gas Fireplace Heaters



Products:

CLASS 2901 84: DOMESTIC HEATERS (GAS) Vented Fireplace: Certified to US Standard

CLASS 2901 04: DOMESTIC HEATERS (GAS) Vented Fireplace

The fireplaces are permitted for indoor use only. “Indoor” is defined as a conditioned space. The fireplaces are not approved for outdoor or partial outdoor installation. The fireplaces must be installed while maintaining required clearances. Installation is recommended in living spaces such as bedrooms, living rooms, great rooms, etc. The fireplaces are not approved for closet installation. The fireplace must be installed according to Ortal requirements in addition to any local codes that may apply, such as USA: ANSI Z223.1/NFPA 54, Canada: CSA B149.

! IMPORTANT:

- Consult the authority having jurisdiction to determine the need for a permit prior to starting the installation.
- It is the responsibility of the fireplace dealer and installer to ensure that this fireplace is installed and framed in compliance with these instructions and all applicable codes.
- Before starting, take careful note of **ALL** the **WARNINGS** in this manual.

Models

Series	Models	Burner	Certification Standard	Available Gas Types	Venting
Wilderness 44H	Wilderness 44H Front Wilderness 44H RS Wilderness 44H LS Wilderness 44H TS	Driftwood Log Set	US: ANSI Z21.88 - 2016 Canada: CSA 2.33 - 2016	Natural Gas or Propane	5"x8" Co-axial Direct Vent

! NOTE: Venting is not supplied by Ortal with the fireplace. The fireplace is certified to be used with, and can be obtained from, the vent manufacturers outlined in “General Venting Requirements” section.

Rating Label

The fireplace rating label is found on a metal plate separate included with the fireplace.

DEALERS/INSTALLERS: You **MUST** leave the fireplace's rating label with the fireplace in an area easily accessible by the owner (typically near the access panel, if available). You must instruct the owner before handing over the fireplace where this label can be found.

OWNERS: Make sure the installer leaves your fireplace's rating label in an area that is easily accessible for you. This information is required for servicing and receiving replacement parts.

ORTAL [®]			
Manufacturer/Fabricant Ortal Ltd. 14 Haharash St. Hod Hasharon, 4524087 Israel Tel: 011-972-9-7402828 Fax: 011-972-9-7402687		For use only with vent, glass and interior design media certified and approved for use with the appliance. Not for use with solid fuel. For use with barriers certified for this appliance only. Utilisez uniquement avec des conduits, des panneaux vitrés et des accessoires décoratifs intérieurs homologués et approuvés pour une utilisation avec cet appareil. Pas pour l'usage avec le combustible solide. Pour une utilisation avec des barrières certifiées pour cet appareil uniquement.	
Serial No.:		Approved By: Homologué Par:	CSA No.: 2358468
Tested to: CSA/ANSI Z21 88-2016 • CSA 2 33-2016 for Vented Gas Fireplace Heater Examiné à: CSA/ANSI Z21 88-2016 • CSA 2 33-2016 pour Foyer au gaz à évacuation			
Altitude rating: Estimation d'altitude:	0-2000 ft. / 0-610 m.	Electrical Rating: Estimation Électrique:	110 volt / 60 Hz / less than 5A
Model Series / Modèle Série: Wilderness Driftwood			
<input type="checkbox"/> Wilderness 44 Front RS/LS/TS <input type="checkbox"/> Wilderness 51 Front RS/LS/TS <input type="checkbox"/> Wilderness 60 Front RS/LS/TS <input type="checkbox"/> Wilderness 44H Front RS/LS/TS <input type="checkbox"/> Wilderness 51H Front RS/LS/TS <input type="checkbox"/> Wilderness 60H Front RS/LS/TS <input type="checkbox"/> Wilderness 44HH Front RS/LS/TS <input type="checkbox"/> Wilderness 51HH Front RS/LS/TS <input type="checkbox"/> Wilderness 60HH Front RS/LS/TS <input type="checkbox"/> Wilderness Traditional 28i <input type="checkbox"/> Wilderness Traditional 36 <input type="checkbox"/> Wilderness Traditional 36S <input type="checkbox"/> Wilderness Traditional 42 <input type="checkbox"/> Wilderness Traditional 51			
Fuel Type/Type de combustible:		<input type="checkbox"/> NG/GN	<input type="checkbox"/> PROPANE
Max Input / Débit max. (BTU/HR):		32,163	31,400
Min Input / Débit min. (BTU/HR):		15,696	21,400
Orifice Size / Taille de l'orifice:		320-160-320 380	90-60-90 180
Gas Inlet Pressure (W.C.) inches: Pression d'entrée de gaz (CE) pouces:		7.0	11.0
Gas manifold Pressure (W.C.) inches: Pression d'alimentation (CE) pouces:		4.7	4.7
Clearances to Combustibles (with included standoffs): Espace par rapport aux matériaux inflammables (avec entretoises inclus):		Sides: Côtés: 0"	Back: Arrière: 0" In front of Glass Devant le panneau vitré: 40"
Also adhere to clearance diagrams and instructions included in the ORTAL manual. Adhérer également aux schémas d'espacement et des instructions figurant dans le manuel ORTAL.			
SKU: M209-WILD-DRIFT			

Wilderness Driftwood Log Set Rating Label

Zero-Clearance Stand-Offs

Fireplace has zero-clearance stand-offs fastened to the body of the fireplace as shown in the figures below. Stand-offs must be fully extended upon installation.

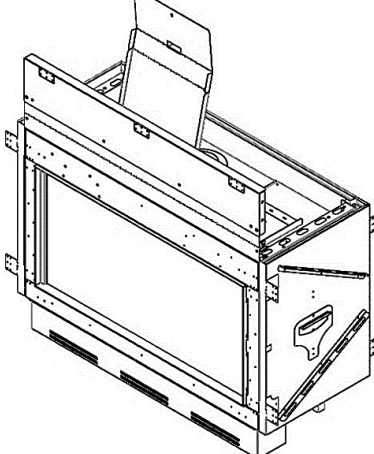

Zero-Clearance Stand-Offs (Isometric View)

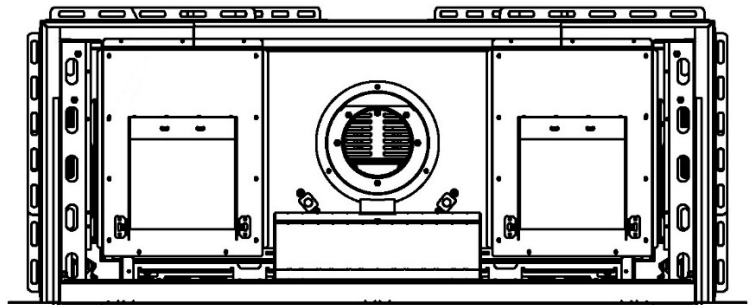

Zero-Clearance Stand-Offs (Top View)

Installation

Prior to Installation

Locate the Fireplace

Keep the following factors in mind when selecting a location for the fireplace:

- Fireplace clearance requirements (review “General Clearances” sections).
- Heat release and air intake requirements (review “Heat Release” and “Air Intake” sections).
- Adequate space for servicing.
- Access panel recommendations (review “Access Panel” section).
- Minimum vertical vent rise, allowed horizontal lengths, and degree of offset (review “Venting” section).
- Framing and finishing requirements (review “Framing” and “Finishing” sections).
 - Front wall installation and finishes to be completed after fireplace and vent installation (review “Step-By-Step Chase Construction” section).
- Floor or Platform requirements (review “Platform” section).

Fireplace Installation

Use the following guidelines to ensure a smooth installation. The installation sequence is divided into three phases: Planning, Installation, and Startup.

First Trip to Site: Planning

Consult with the contractor and go over all requirements:

- Chase framing requirements.
- 5/8” Type X Drywall (or equivalent) requirements.
- Heat release requirements.
- Air Intake requirements (if applicable).
- Access panel size and location.
- Gas and electric specs and location.
- Vent configuration.
- Finishing details.

 **NOTE: Provide the contractor with a printed copy of the “Building Checklist” and review requirements with them.**

Second Trip to Site: Installation

- Confirm the following items are properly located and built to specification:
 - Framing (with 5/8” Type X Drywall as applicable)
 - Platform
 - Gas and electric
 - Access panel (if applicable)
 - Heat release
 - Air intake (if applicable)
- Clear a path free of any possible obstruction to carry in the fireplace.
- Uncrate the fireplace and set in place.
- Make sure all zero-clearance metal stand-offs on the outside of the fireplace are fully extended.
- Secure the fireplace to the framing by attaching the nailing flanges to the framing. See “Securing the Fireplace” section below.
- Remove all zip ties.
- Optional: Remove gas and electrical components from metal shipping plate if desired.
- Move the components to the access panel location. Be mindful of the routing for future service needs.
- Connect the light grounding cable to the fireplace leg closest to the access panel.
- Install the vent components. See “Vent Installation” section below.
- Review the front wall requirements (see “Step-By-Step Chase Construction” section) and finishing details with the contractor.
- Protect the fireplace and components from damage.

Securing the Fireplace

The fireplace has nailing flanges attached to the upper and lower face of the front of the fireplace (highlighted in grey on “Nailing Flanges” image). The nailing flanges are to be attached into the framing upon installation. It is crucial to the finishing that the fireplace is stable, level, and plumb. For added stability (though not required), re-use the shipping brackets to secure the legs of the fireplace to floor/platform.

Vent Installation

Venting must be installed according to the requirements detailed in the “Venting” section of this manual in conjunction with the vent system manufacturer’s installation instructions. Venting must be supported by the structural surrounding and not by the fireplace. Each offset (elbow) must be strapped to reduce movement or possible disconnection.

The first section of venting must be secured to the fireplace starter collar with a minimum of 3 sheet metal screws no longer than ½”. DO NOT use silicone to seal the sections. If sealing is required by the vent manufacturer or local code, use Mil-Pac sealant.

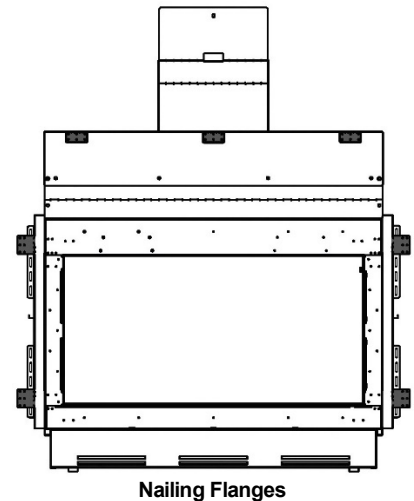

Third Trip to Site: Startup

- Perform a visual inspection to confirm that all work was completed correctly and per specification.
- Confirm that gas and electric are properly connected and live.
- Remove the safety barrier and glass and clean the inside of the fireplace.
- Install the Driftwood Logs on the burner as specified in “Log Placement” section.
- Confirm the log placement is set up per specification.
- Confirm the fireplace is operating properly.
- Check remote-control setup.
- Remove protective layer from glass
- Clean glass.
- Reinstall the glass and safety barrier.
- Review operation of the fireplace and remote control with the owner.
- Set up return visit to clean glass after the Initial Burning Period (see “Post-Installation” section below).

Post-Installation

Complete the following post-installation steps upon 4th trip to site.

Initial Burning Period

There is a 12-hour minimum burning period following installation of the fireplace. This 12-hour period must include a minimum of 4 consecutive hours of continuous burning. During this time, the owner or installer may notice:

- The glass developing a white or “cloudy” residue
- An unusual smell

Both the residue and the smell are due to the paint on the fireplace metal heating and “burning off”. This is normal. The cloudiness and odor will disappear after the 12-hour period elapses and the installer returns to service the fireplace and complete startup.

Final Inspection Procedure

When the 12-hour burning period is complete, the installer must return and perform the final inspection, which includes:

- Cleaning the glass with a ceramic glass cleaner (otherwise the white residue will remain)
- Checking the interior media setup
- Checking for gas leaks
- Adjusting the restrictor (if necessary)
- Performing an overall check to make sure that everything is working properly

When these activities are complete, initial startup is concluded and the fireplace may be operated by the owner.

Final Checks and User Instruction

Before releasing the fireplace to the customer for use without installer supervision, the installer must ensure that the fireplace is burning correctly. In addition, the installer must review and explain the following to the owner:

- Safety warnings
- Fireplace operation
- Warranty requirements
- Maintenance requirements
- Glass is hot during and after operation
- If any questions or concerns arise, owner must contact the local Ortal dealer/installer for support.

Building Around the Fireplace

Building Checklist

The following building checklist is a quick reference for a typical Ortal Wilderness 44H Series fireplace installation. This list is not exhaustive and does not supplement thorough review of the installation manual.

- ☑ **Fireplace Location:** Ensure the location allows for min. 40" clearance from viewing area to furniture and other combustibles. Make sure a clear path is established to allow the fireplace to be safely transported to installation location.
- ☑ **Venting:** Confirm vent size (5"x8"), vent clearance (1" on sides and bottom, 3" on top), vent configuration, and termination location.
- ☑ **Platform Height:** Determine desired fireplace viewing area location on the wall. Average height of bottom of glass to the floor is 12"-24". Platform must be able to bear the weight of the fireplace. Platform can be constructed out of wood, concrete, metal, or any other solid materials (not required to be non-combustible). A platform is not required. The fireplace may sit directly on the floor. The floor has the same construction requirements as a platform.
- ☑ **Chase Construction:** No materials can be attached directly to the fireplace (exceptions: 5/8" Type X Drywall). The area of the chase interior must be min. 124 square inches at any given point within the chase.
- ☑ **Framing:** Adhere to minimum framing dimensions (or greater). The first 18" above the top of the fireplace viewing area must always be non-combustible framing. Maintain min. 1/4" clearance from front face of fireplace and front metal off-set to the framing. For recessed fireplaces, do not exceed 12" max. front overhang depth limit. No material is permitted to extend past the 1/2" metal lip surrounding the fireplace viewing area.
- ☑ **5/8" Type X Drywall Requirements:** One layer of 5/8" Type X Drywall (or equivalent) must be installed on the exterior of the chase framing. 5/8" Type X Drywall (or equivalent) may be fastened to the front face of the fireplace with 1" self-tapping drywall screws 16" on center a minimum of 2 1/2" from the metal lip (above the viewing area).
- ☑ **TV/Artwork:** TV/Art must be min. 12" above top of fireplace viewing area. First 18" min. above the viewing area must have non-combustible framing (top front metal stand-off + non-combustible studs).
- ☑ **Gas Supply Line and Power Location:** Locate gas line with manual shut off according to local code. Power provided by single gang 120V outlet in same area as gas line.
- ☑ **Access Panel:** Access panel highly recommended to access gas and electrical components for servicing. Depending on the model, access panel can be placed at side or back of the fireplace within 3' of the pilot. Access panel is required for power-vented fireplaces. Min. size 10"x10".
- ☑ **Heat Release:** *Crucial for Cool Wall Technology.* Must start within 6" (max.) from the chase's ceiling. Min. heat release size is 124 sq.in. of net free air space. Height of the heat release must not exceed 1/3 of the width.
- ☑ **Air Intake:** Only required for double glass heat barrier. Must be located at or below level of double glass fans. Min. 124 sq.in. of net free air space.
- ☑ **Finishing:** Maintain required clearances depending on your finish material.

Framing

Fireplace chase may be framed with either combustible (typically wood studs) or non-combustible framing (typically metal studs). Any framing within 18" from the top of the fireplace glass (viewing area) must be non-combustible.

The framing of the fireplace chase must be designed to carry the entire weight of the wall and finish material. Surrounding material must not transfer weight to the fireplace or be connected in any way to the fireplace, with the exception of 5/8" Type X drywall (or its equivalent). It may be fastened to the front face of the fireplace with 1" self-tapping drywall screws 16 inches on center, with a minimum of 2 1/2 inches from the metal lip (above the viewing area).

No material is permitted to extend past the 1/2" metal lip surrounding the fireplace viewing area. This area must be unobstructed to allow the heat barrier and inside glass panel to be removable.

Framing Dimensions

The following diagrams are for illustrative purposes only. There are multiple approved installation scenarios. A flush application is not the only permitted application. The fireplace may be recessed into the wall. Refer to diagrams and values below and in the following pages for details.

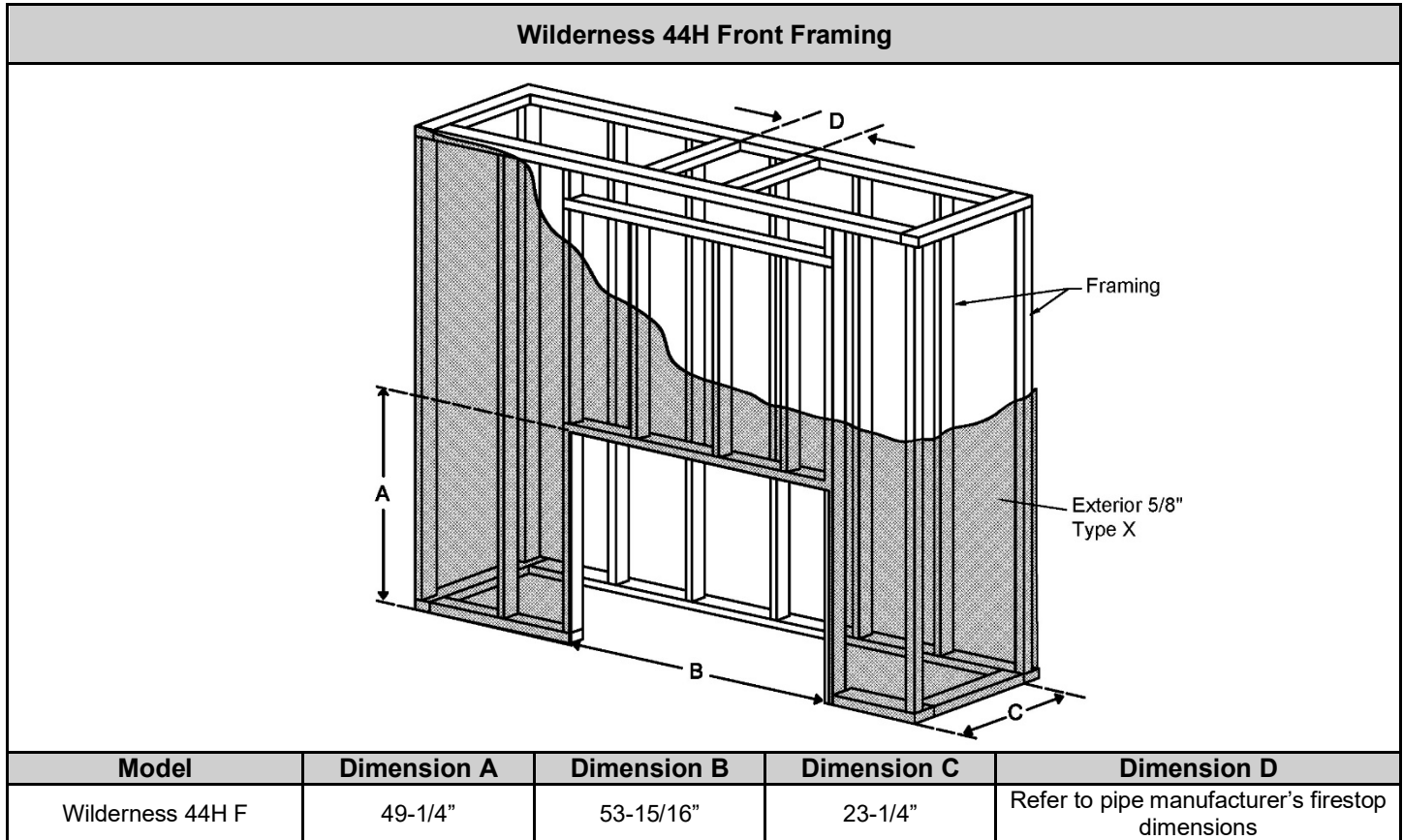

Wilderness 44H Corner (RS/LS) Framing

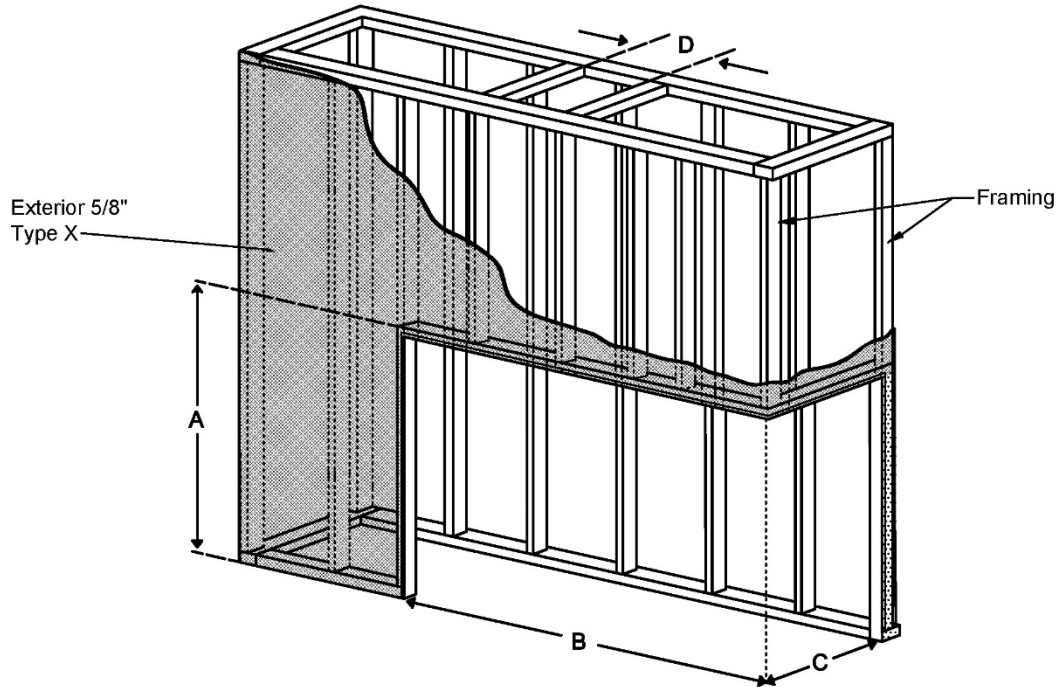

Model	Dimension A	Dimension B	Dimension C	Dimension D
Wilderness 44H RS/LS	55-9/16"	51-15/16"	23-1/4"	Refer to pipe manufacturer's firestop dimensions

Wilderness 44H Three Sided Framing

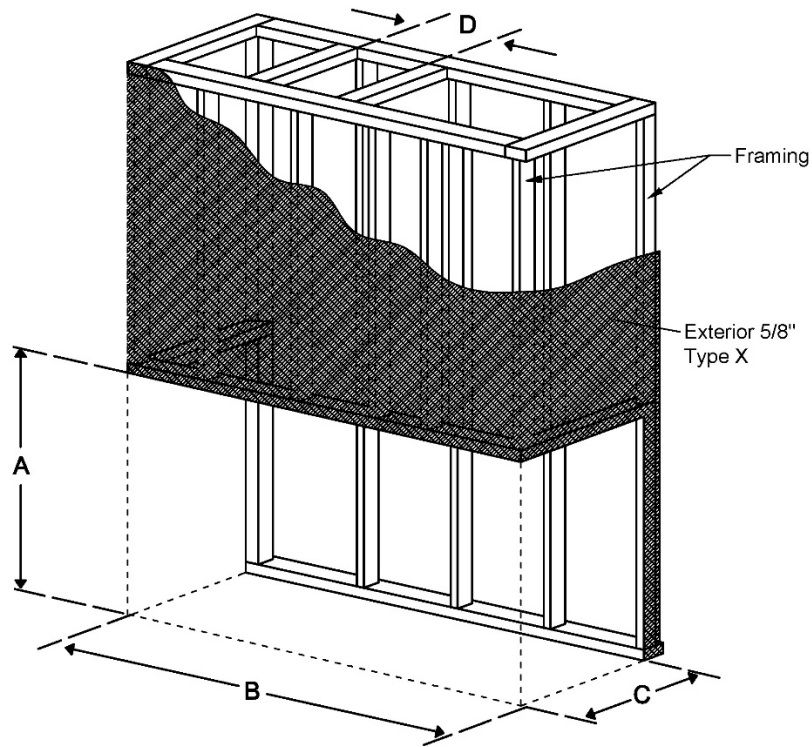

Model	Dimension A	Dimension B	Dimension C	Dimension D
Wilderness 44H TS	55-9/16"	48-15/16"	23-3/4"	Refer to pipe manufacturer's firestop dimensions

5/8" Type X Drywall Requirements

Framing must be covered with 5/8" Type X Drywall (or equivalent). The chase interior does not require a layer of 5/8" Type X Drywall (or equivalent). The chase interior does not require a non-combustible layer.

! NOTE: 5/8" Type X Drywall (or equivalent) is not required on the exterior portion of an insulated outside-facing wall.

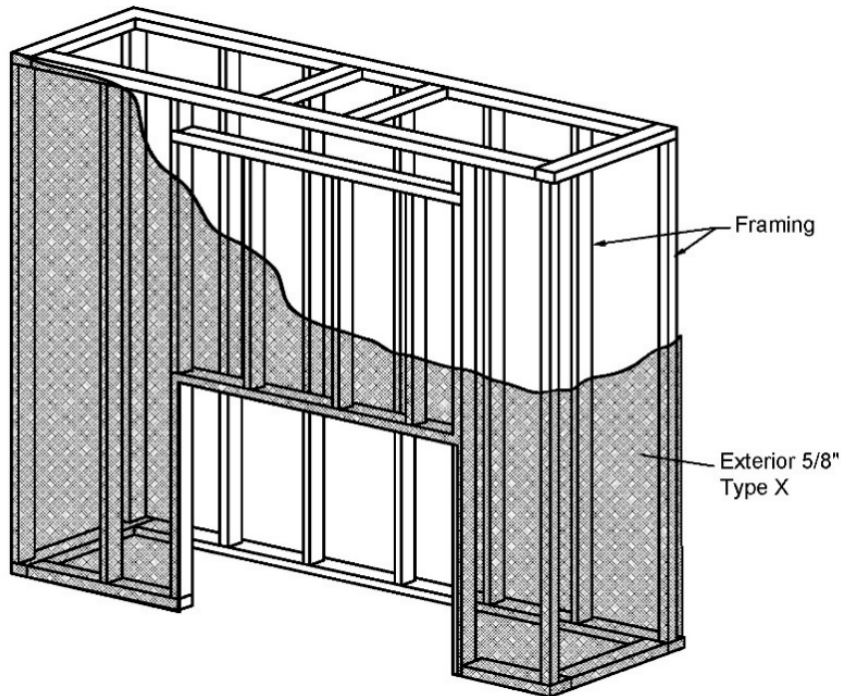

Platform

The fireplace must be installed on a flat, solid, continuous surface. Surface can be wood, concrete, metal, and other typical solid floor types. Surface material is not required to be non-combustible.

To raise the fireplace higher than standard height, build a platform to which the fireplace can be secured. Platform must be stable and able to bear the full weight of the fireplace. Platform can be constructed out of wood, concrete, metal, or any other solid materials. Material is not required to be non-combustible.

To lower the fireplace, it must be recessed into the floor. Fireplace legs cannot be removed, cut, or adjusted.

General Clearances

Non-Combustible Zone

Furniture and other combustibles are not permitted within the non-combustible zone. The non-combustible zone is an area that extends 40 inches perpendicular from the fireplace glass. Combustibles are permitted below and around the non-combustible zone.

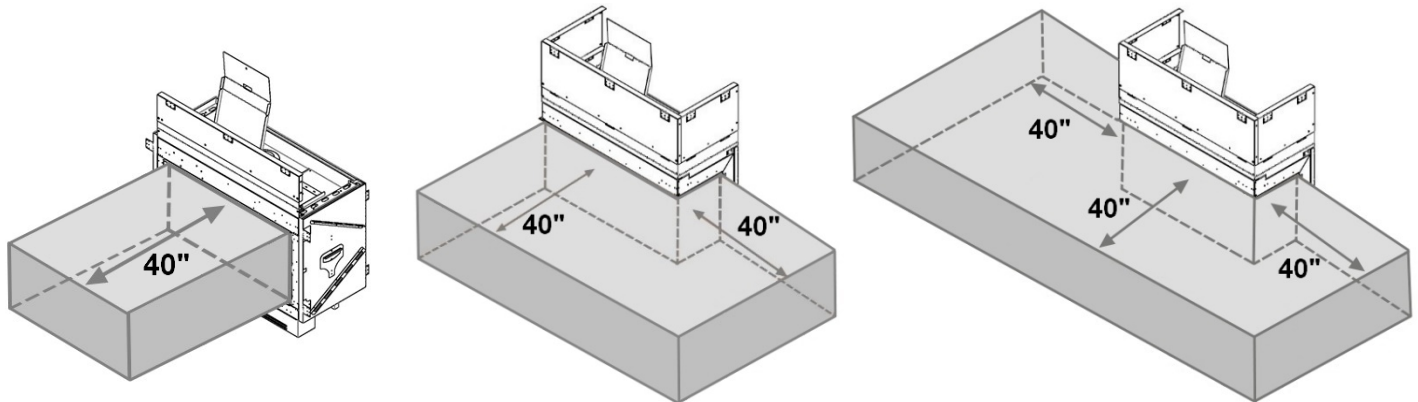

Non-Combustible Zone

Framing Clearance

Maintain a minimum 1/4 inches of space between the framing and the face of the fireplace/front stand-off.

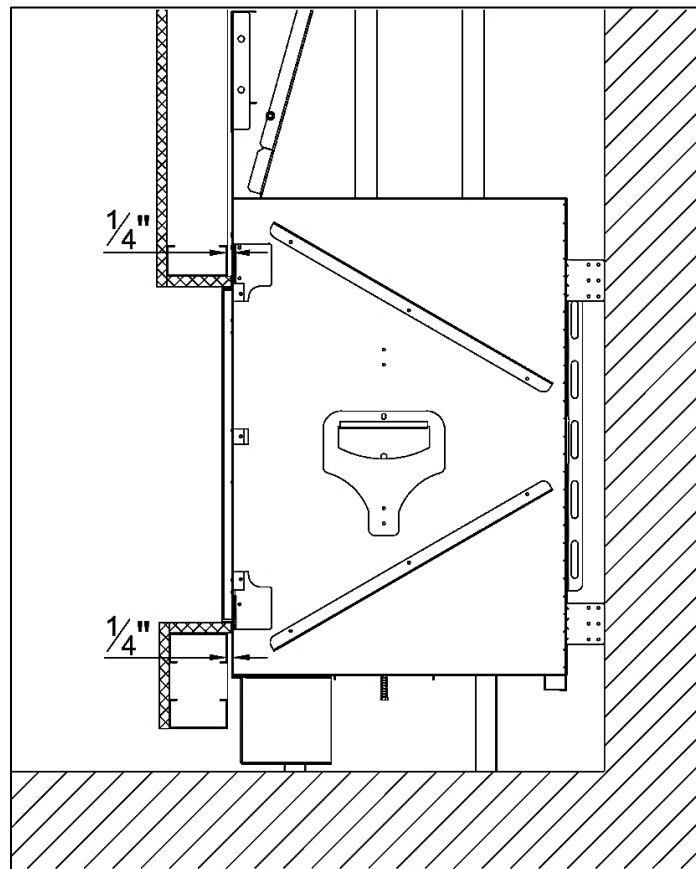

Clearance to a Side Wall

The following requirements apply to the front glass of the fireplace. It does not apply to the *side glass* of a Corner or Three Sided fireplace.

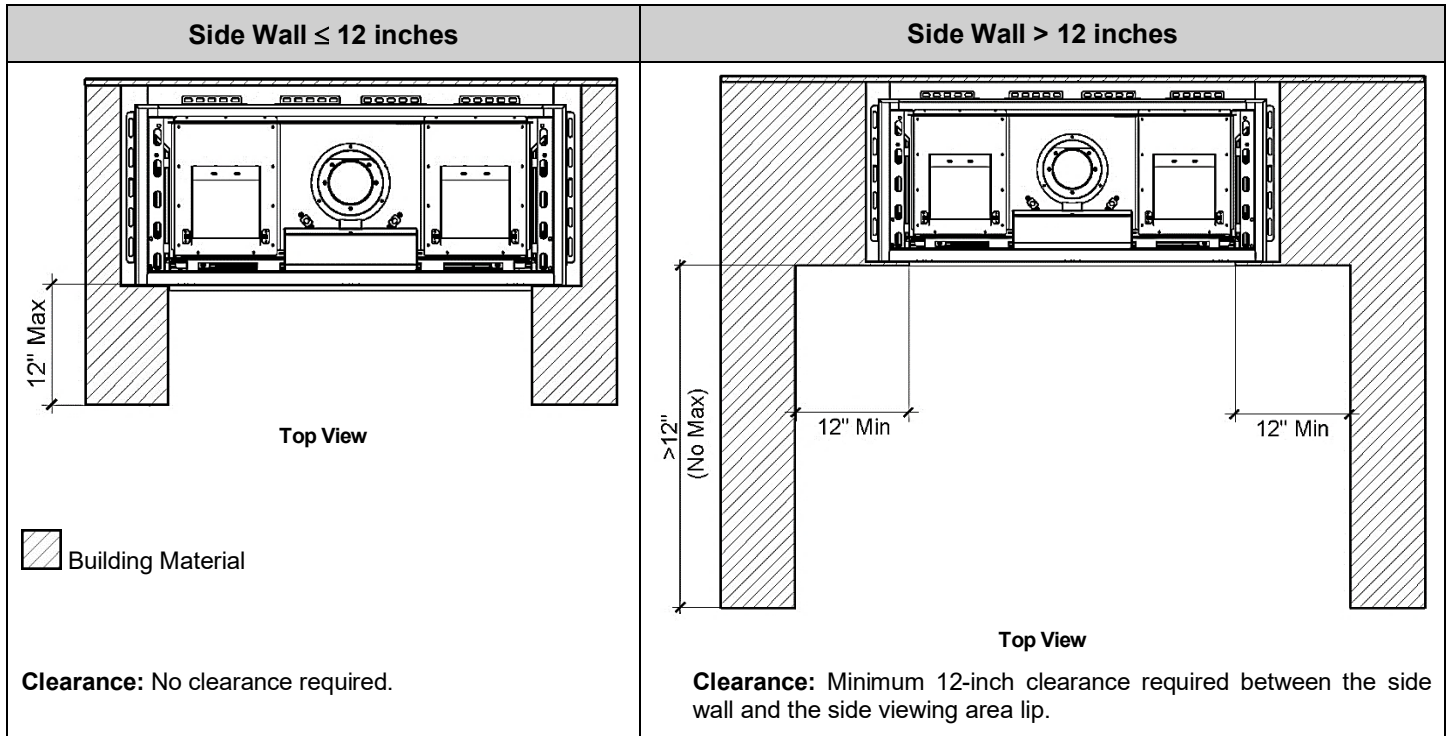

Maximum Overhang Depth

Overhang depth of a recessed fireplace must not exceed the clearances shown in the diagrams below. Overhang depth is measured from the edge of the fireplace lip to the out-most part of the wall (including finish material).

Bottom recess (or "hearth extension") has no minimum or maximum depth requirement. If bottom recess depth exceeds 12", ensure the structure is capable of supporting the weight of a fireplace technician for servicing.

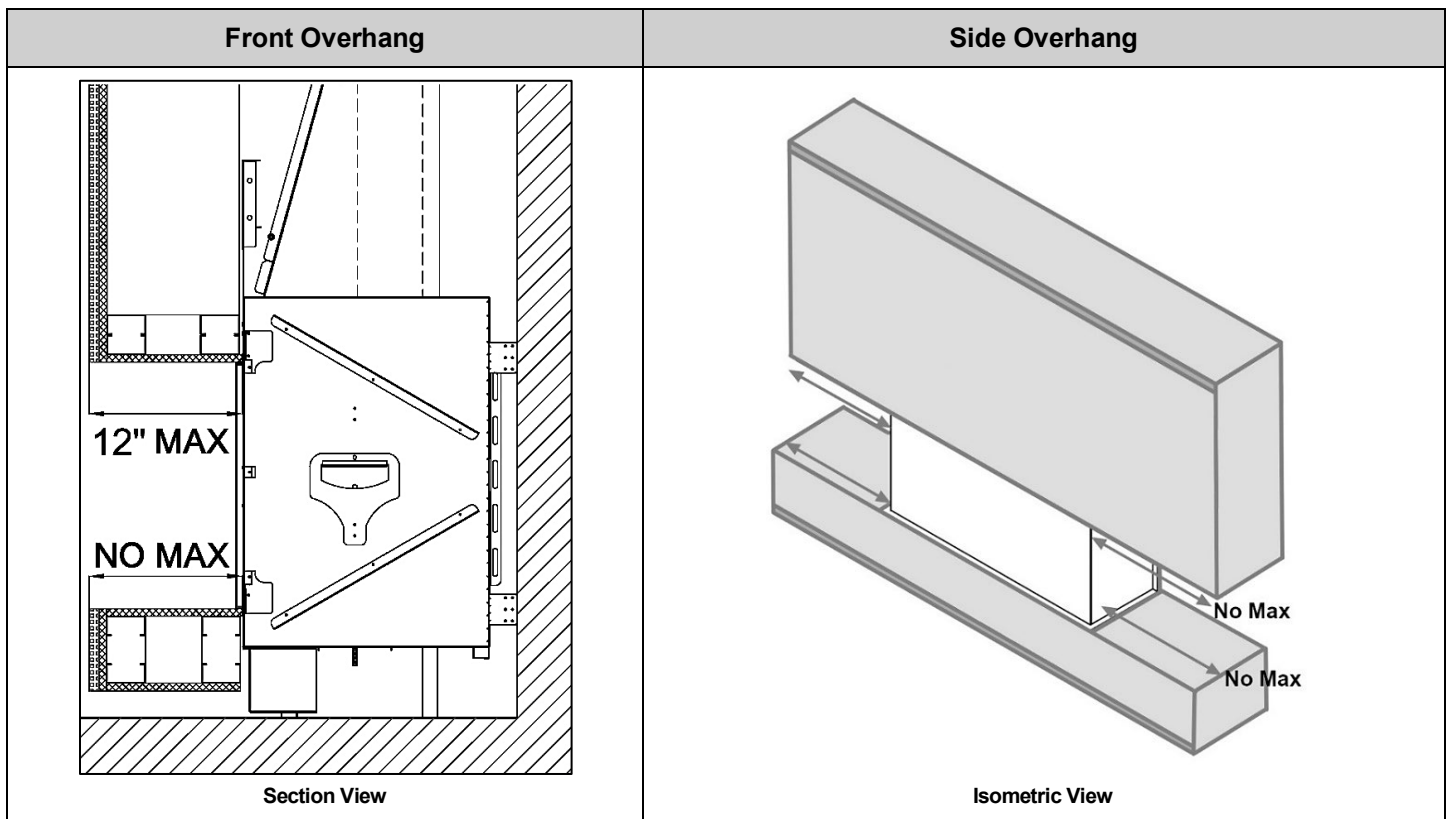

Heat Release

A heat release is an opening in the fireplace chase that allows the heat inside the chase to passively circulate into an interior room. This heat is generated convectively as the fireplace heats up. It is separate from exhaust heat produced at the combustion chamber of the fireplace. **A heat release is required** to keep the wall around the fireplace cool.

Heat Release Requirements

- The heat release must be located at or near the top of the fireplace chase and **start within** 6 inches (0-6 inches max) of the chase ceiling (draft stop). It can start at the chase ceiling. It can be located on the front, sides or back of the chase. It can be released into any interior space that shares a wall with the chase.
- The heat release cannot be vented outdoors as this would expose the fireplace to outdoor elements.
- Minimum heat release size requirement depends on heat release orientation:

Horizontal Heat Release	Vertical Heat Release
Minimum 124 sq. in. of net free air space	Minimum 160 sq. in. of net free air space

- For horizontal heat releases, the height of the heat release must not exceed 1/3 of the width. The heat release must be 2/3 wider than it is tall.
- The heat release can be in the form of (but not limited to) a louvered ventilation grille, gap, or reveal.
 - For louvered ventilation grilles, the net free air space allowed in the louvered area must be equal or greater than the minimum number of square inches required per fireplace.
- The interior area of the narrowest part of the fireplace chase (in square inches) must never be less than your required heat release size (see "Chase Area Minimum" section for details).

The following diagrams are examples of potential heat release options. These drawings serve as illustrative purposes only.

Horizontal Heat Release

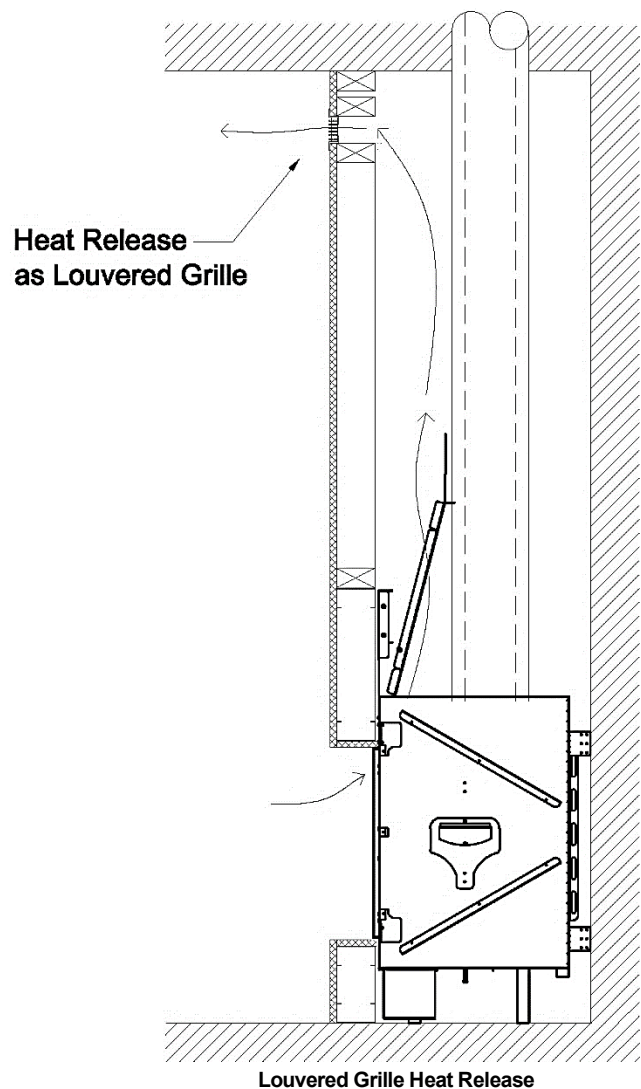
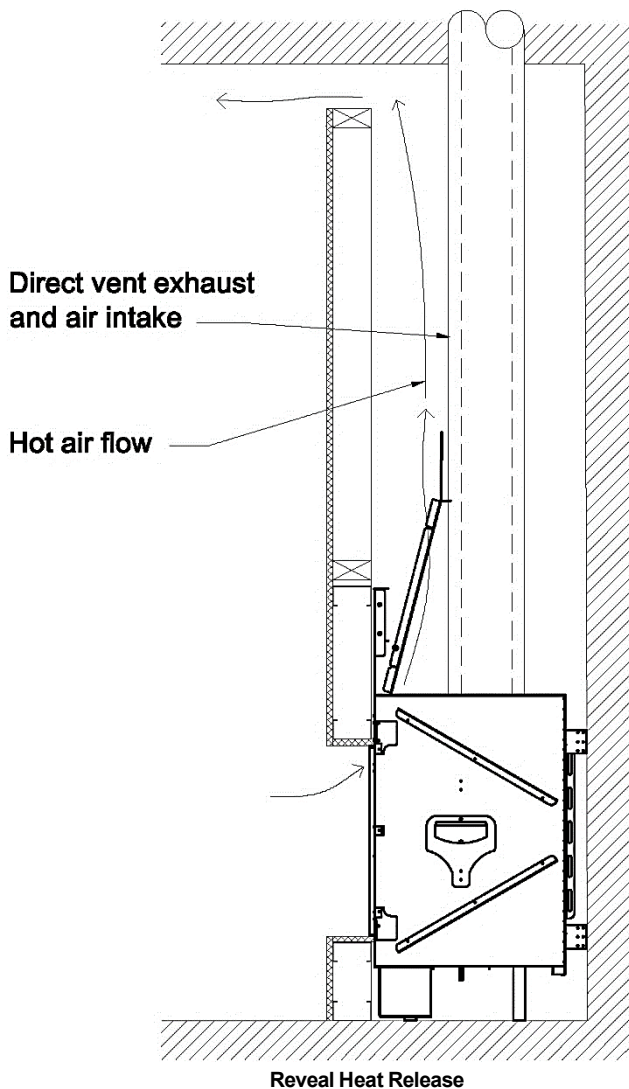

Vertical Heat Release: Split Front

The heat release is oriented vertically and split between the two sides of the chase.

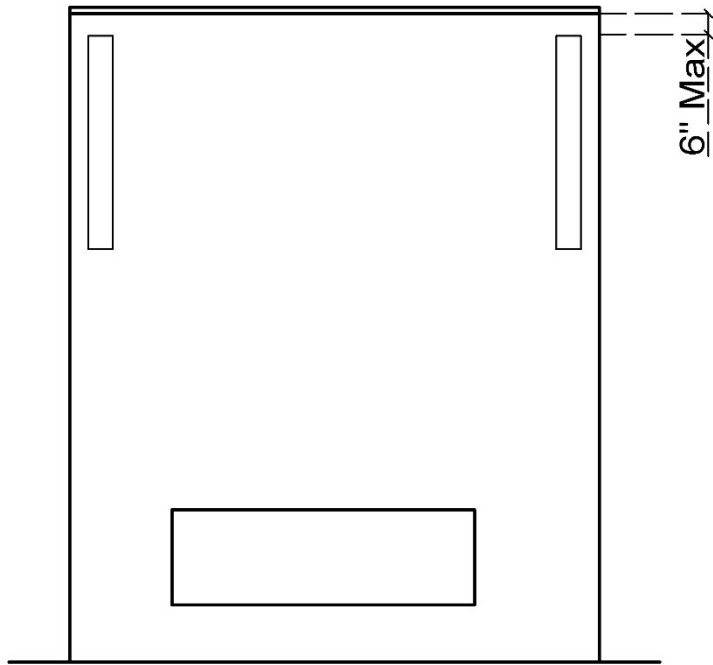

Split Front Vertical Heat Release

Vertical Heat Release: Full Side

The heat release is oriented vertically. Entire heat release is on one side of the fireplace chase.

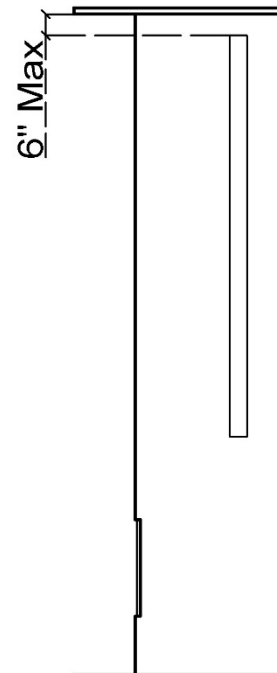

Full Vertical Heat Release on One Side

Sprinkler Clearance to Heat Release

In a situation where a sprinkler head is near the heat release, the sprinkler head must be minimum 60 inches (linear length) from every point of the heat release opening.

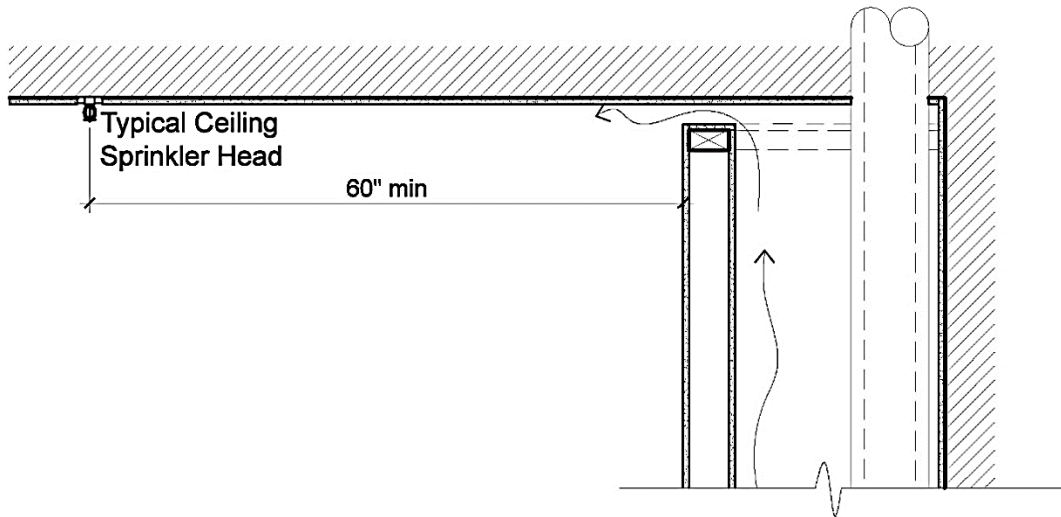

Air Intake

When installing a fireplace with a double glass heat barrier, it is essential to maintain cool air flow between the double glass panels. For this purpose, an opening must be provided toward the bottom of the wall to allow the double glass fans to circulate room air through the glass panels and up into the chase. This opening, called an air intake, needs to be made before closing the wall surface below the fireplace. Air intake must meet the minimum size requirement.

Air Intake
Minimum 124 sq. in. of net free air space

The air intake can be in the form of a louvered ventilation grille, gap, or toe-kick (reveal). For louvered ventilation grilles, the net free air space allowed in the louvered area must be equal or greater than the minimum number of square inches required per fireplace.

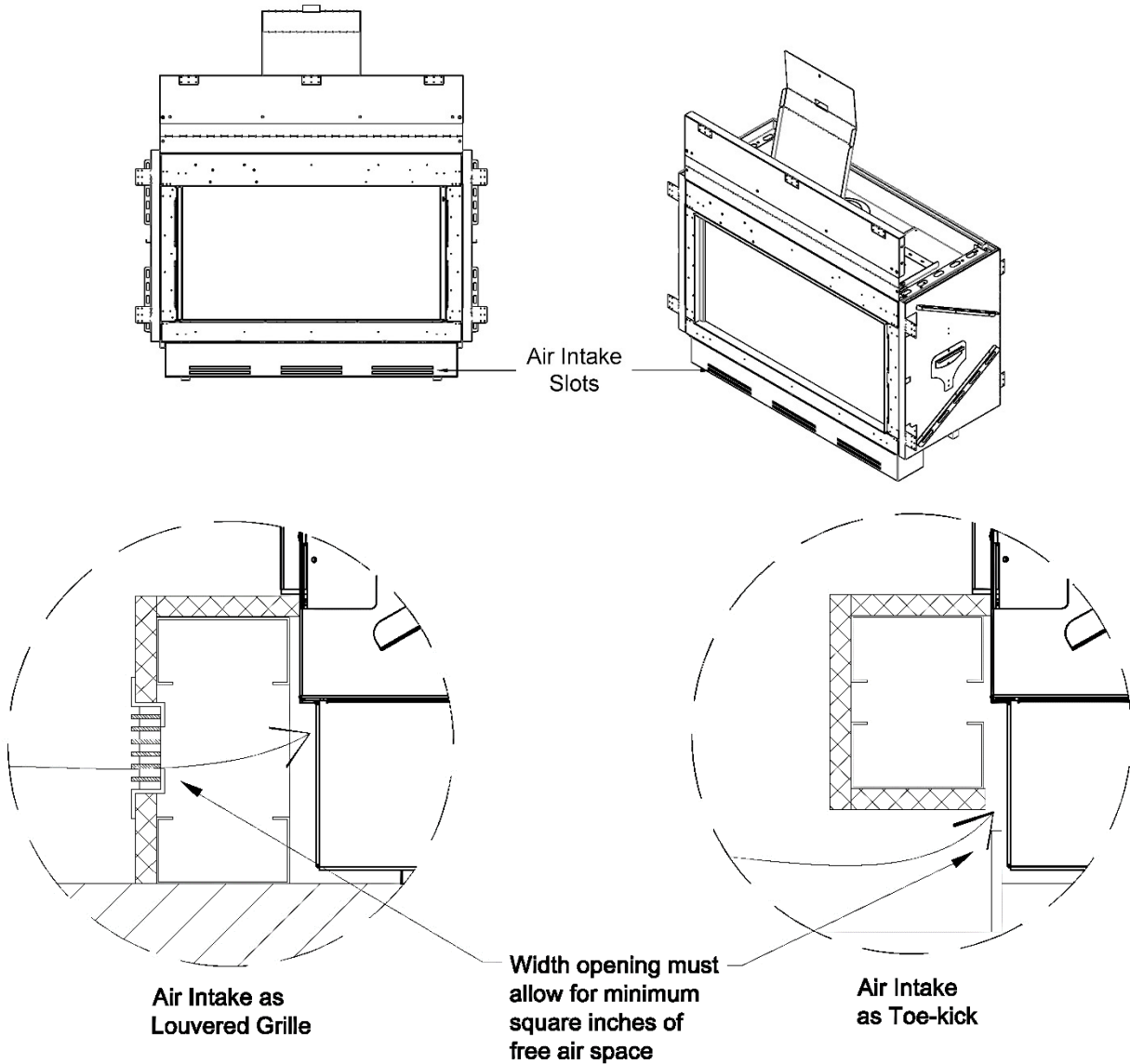

The entire air intake must be located at or below the level of the double glass fans. The air intake is not required to be on the front wall of the fireplace. The air intake cannot be on a wall that allows air from outside the house directly into the fireplace chase. Air must be from a conditioned space. **Air flow must be able to get to the double glass fans through the air intake slots in the protective bracket at the bottom of the fireplace.**

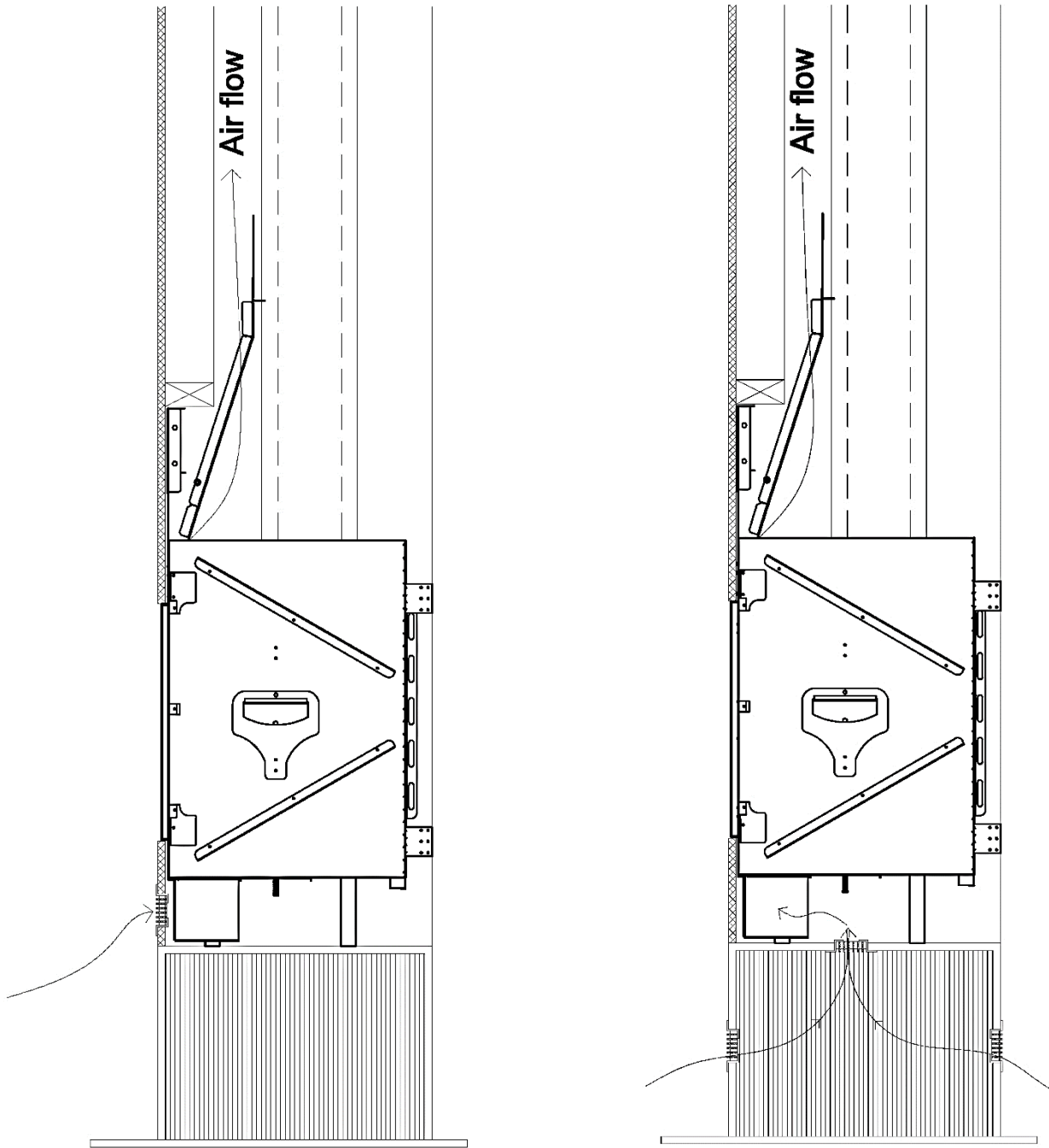

Air Intake for a Platform



LEGEND

-  5/8" Type X Drywall
-  Combustible Framing

 **NOTE:** Please refer to the “Platform” section for details on platform construction.

Mounting a TV/Artwork

Ortal's Cool Wall Technology is a technique that reduces the convective heat from the fireplace and prevents heat buildup inside the fireplace chase, mitigating any damage that may result from the wall reaching high temperatures. Ortal's Cool Wall system enables the option of safely installing artwork, a TV, or other similar electronic components above the fireplace by reducing the wall temperature above the fireplace.

Location	Wall Temperature
0-6 inches above fireplace	100°F - 120°F
6-12 inches above fireplace	90°F - 100°F
12 inches above fireplace	80°F - 90°F

Required minimum clearance between bottom edge of TV or other similar device or artwork and top of fireplace viewing area is 12 inches.

Maintain the following general requirements to mount a TV or artwork above the fireplace and prevent heat damage:

- Mount the TV or artwork a minimum of 12 inches above the top of the fireplace viewing area.
- TV wires must be routed through framing and cannot pass through the fireplace chase.

The decision to install a television above an Ortal fireplace is up to the discretion of the owner. TV and art manufacturers may specify that their product should not be installed on, near or above a heat source. Ortal will not be held liable for any adverse effects on a TV, artwork or other equipment located near the Ortal fireplace. It is the owner's responsibility to verify that their TV or artwork can withstand the wall temperatures as outlined in the above wall temperature chart.

The following diagrams can be used as a guide for customers who do decide to locate their TV and artwork above their Ortal fireplace. These drawings illustrate ways of reducing the amount of heat impact to the area surrounding the fireplace.

Flush Mounted TV/Artwork

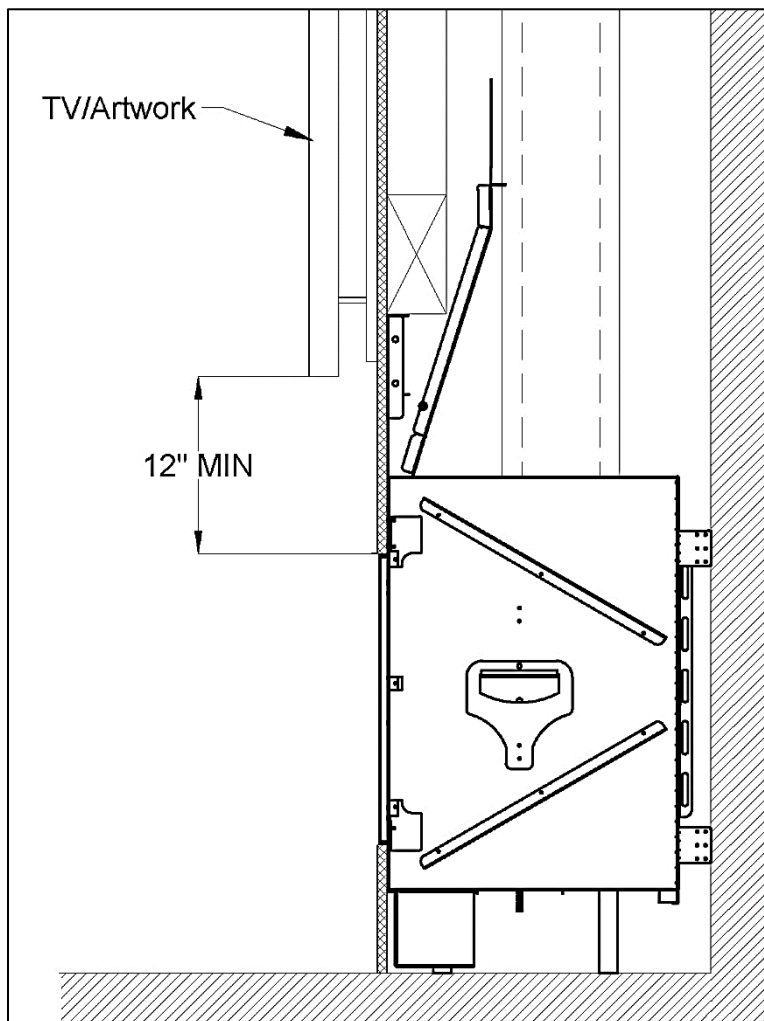

LEGEND

 5/8" Type X Drywall

Recessed TV/Artwork

The top stand-off on the fireplace is composed of two metal panels. The top panel is attached to the bottom panel with a series of bolts. This top panel can be unbolted and removed for recessed TV installations.

The first 18 inches above the top of the fireplace viewing area must be framed with non-combustible framing. The lower stand-off offsets your non-combustible framing distance. Non-combustible framing plus the height of the lower stand-off must be minimum 18 inches.

! IMPORTANT NOTE: When a TV/artwork is recessed above the fireplace, the depth of the fireplace prevents the TV/artwork from being closer than 15" from the top of the viewing area. See diagram below for illustration.

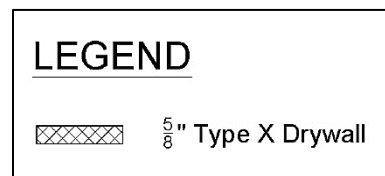
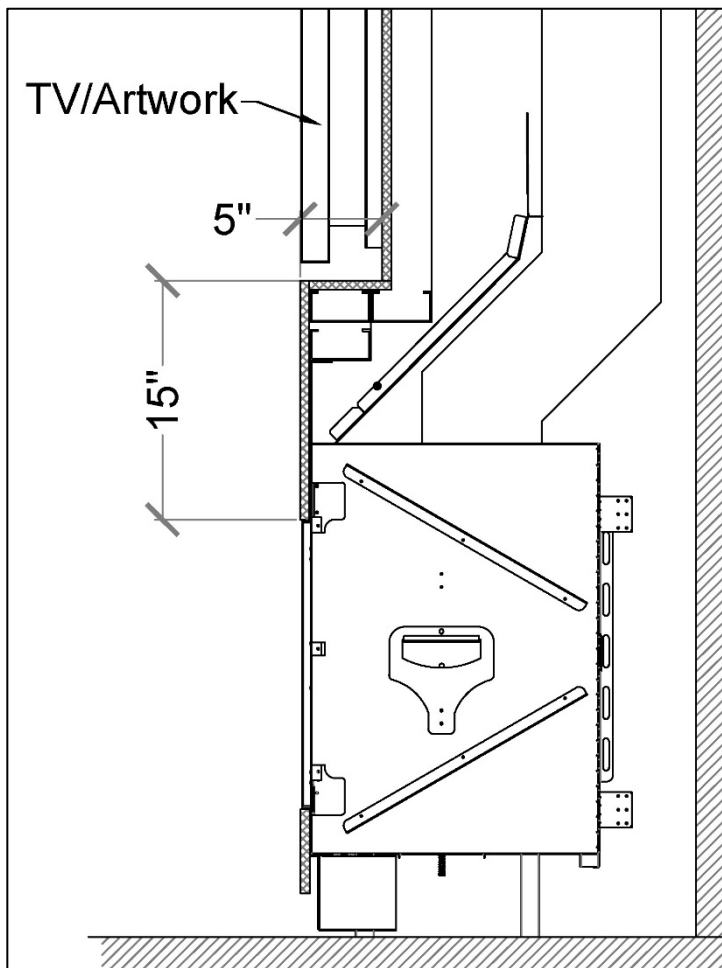
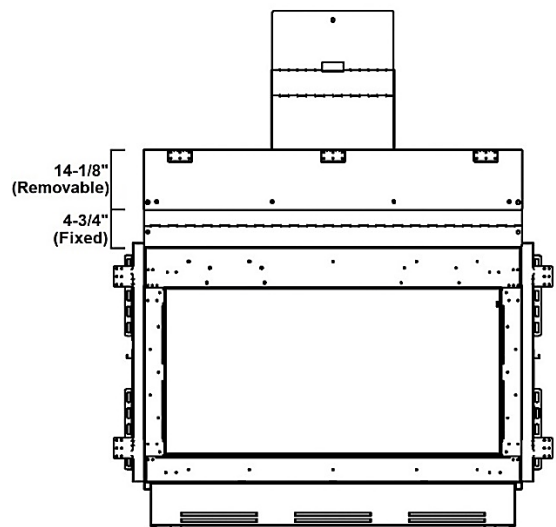

! NOTES:

- The first 18 inches above the top of the fireplace viewing area must be framed with non-combustible framing.

Access Panel

An access panel is not required (see note below for exception), but it is ***highly recommended***. It allows for access to the fireplace's gas and electrical components for servicing.

NOTE: An access panel at the fireplace is ***required*** for fireplaces with a power vent to allow access to the power vent control box for servicing.

Access Panel Size and Location Recommendations:

- Minimum of 10 inches x 10 inches in size
- Located within 36 inches of the pilot to the side or back of the fireplace (see "Routing the Gas Line")

The size and location of the access panel may vary, but in all cases, it must allow the technician to comfortably access and service the fireplace's gas and electrical components. These components are attached to the pilot on a flexible gas line and can be moved within 36 inches of the pilot (located at the center front of the burner) to the side or back of the fireplace.

For ease of access, move the fireplace's gas and electrical components as close to the access panel as possible. **If there is any distance between the access panel and the gas and electrical components, the access panel size must be increased accordingly.** Prior to installation, fireplace dealers/installers should work with the owner, builder, project architects and/or interior designers to determine the best size and location of their access panel.

If an access panel cannot be incorporated, the alternative method of servicing the gas and electrical components is through the fireplace. This procedure requires removing the glass panel(s) and interior design media, and lifting the grill, burner, and bottom pressure release valve. This will increase service time and difficulty. An access panel is always preferred. Fireplace dealers/installers are advised to consult with their clients regarding the advantages and disadvantages of each service option.

The protective bracket at the bottom of the fireplace blocks service access to gas and electrical components. The protective bracket is installed under the glass panel sides of the fireplace, and the location of accessibility varies per model.

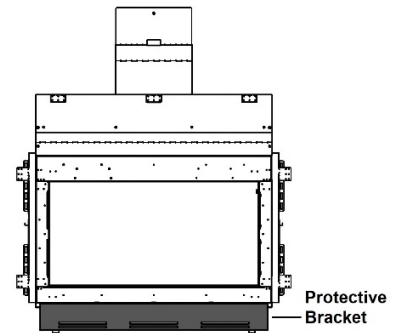

NOTE: If local code requires an access panel, defer to local code requirements.

Gas and electrical components are accessible in the following locations on each model:

Model	Access Location			
	Right	Left	Back	Front
Wilderness 44H Front	✓	✓	✓	
Wilderness 44H LS	✓		✓	
Wilderness 44H RS		✓	✓	
Wilderness 44H TS			✓	

NOTE: Access location is referenced from an elevation viewpoint.

Chase Area Minimum

To ensure the convective heat within the chase passively moves to the heat release at an optimal rate, all parts of the interior of the chase must be **minimum 124 sq. in.** in size at any given point. To determine if your chase meets this requirement, use the following equation at the narrowest part of the chase.

$$\text{Chase Area} = (\text{Chase Length} \times \text{Chase Depth}) - (50.27\text{in}^2)$$

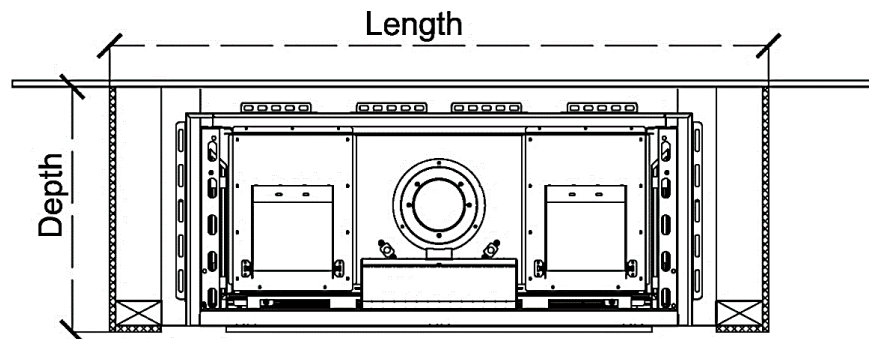

Fireplace Chase (Top View)

If the heat release is split into 25/75 portions due to an oversized ledge, the chase only needs to be the size of 75% of the heat release because 25% of the heat is already being released at the ledge (see "Ledge Detail" section below for details).

Recessed Ledge

A ledge over the top of a fireplace that is less than 24 inches from the top of the fireplace viewing area must maintain a minimum of **12 inches from the top of the viewing area to the bottom of the building material. Entire structure must be non-combustible (framing and finish).**

If ledge surface area exceeds **220 sq.in.**, the heat release must be divided up between the ledge and the chase ceiling: 25% at the ledge and 75% at the chase ceiling.

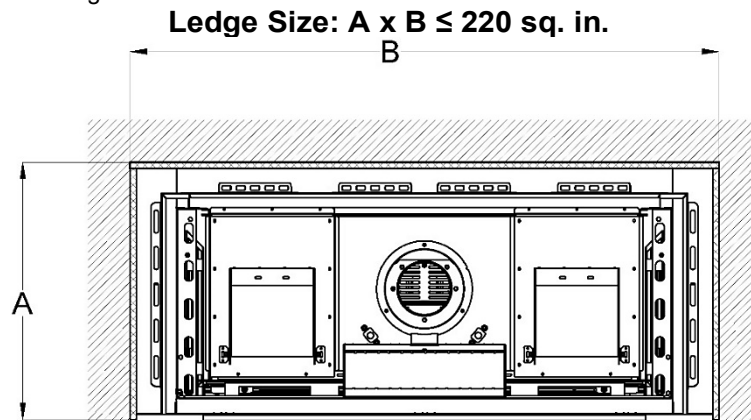

A = ledge depth, B= ledge length (Top View)

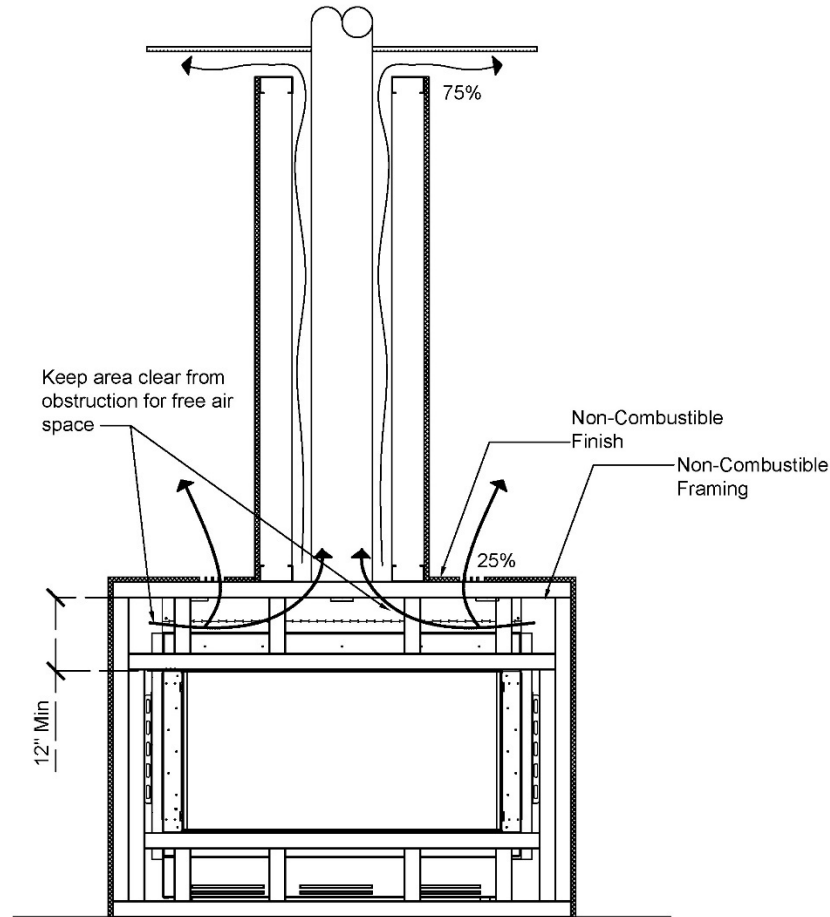

! NOTES:

- Top portion of the top front stand-off must be removed. See "Recessed TV/Artwork" section for details.
- Chase area minimum requirements must be met throughout the entire fireplace chase. See "Chase Area Minimum" section above for details.

Structural Weight Support

The fireplace must not carry any structural weight. The framing must be supported by another surface. Consult with the project structural engineer and refer to your local building codes for proper wall support.

The following drawing shows a recommended approach to this type of installation. Please note that these drawings are not to scale. All fireplace drawings with correct dimensions are available on the Ortol website.

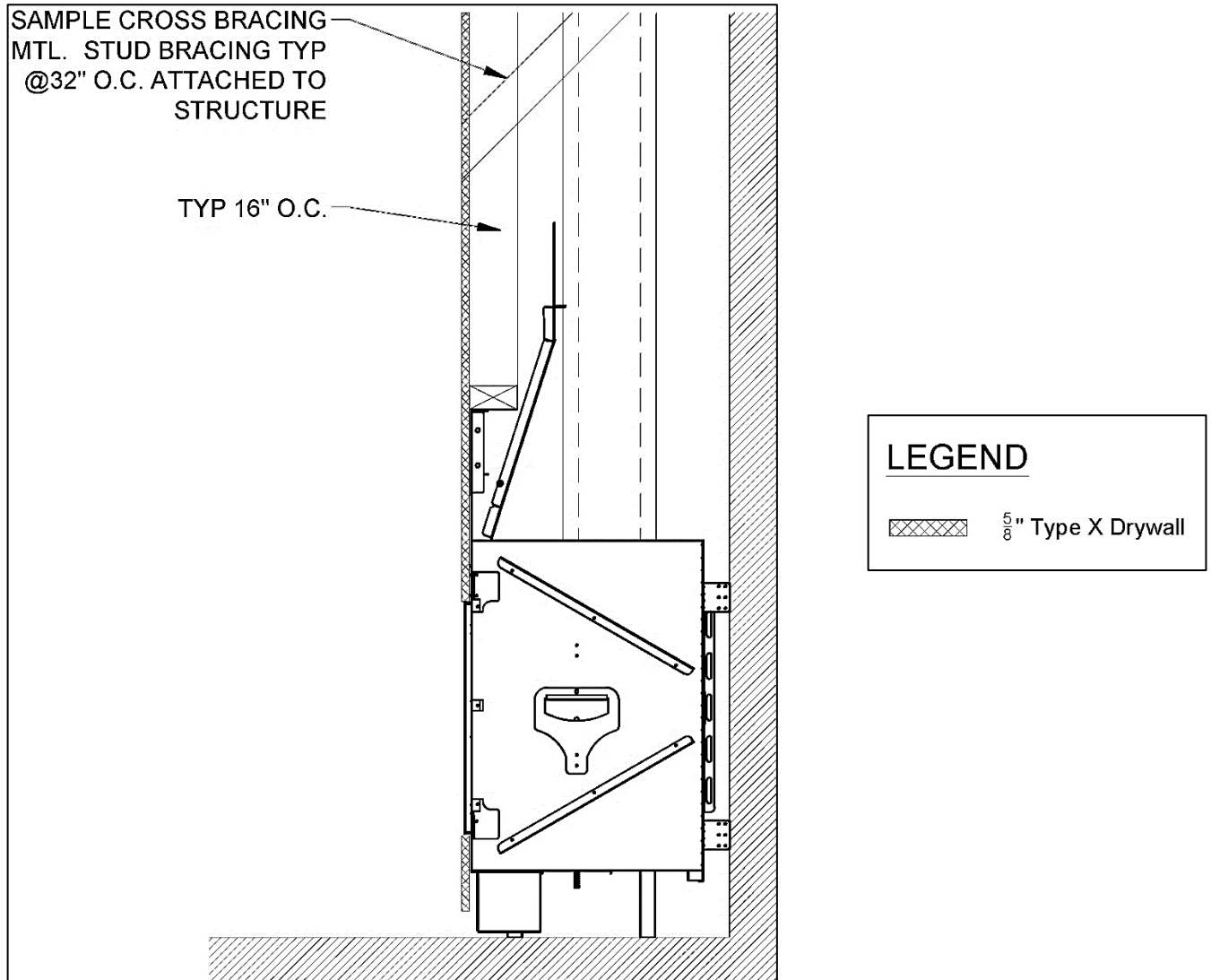

Step-by-Step Chase Construction

The following checklist is a simplified overview of typical chase construction for an Ortal Wilderness 44H Series fireplace installation. This list is not exhaustive and does not supplement thorough review of the installation manual.

Step 1

BUILD BACK AND SIDE WALLS

- ☑ Frame the back and side walls according to framing requirements.
- ☑ Build the platform (if necessary) to the desired height and install inside fireplace chase.
 - Platform must be stable and able to bear the full weight of the fireplace. Platform can be constructed out of wood, concrete, metal, or any other solid materials. Material is not required to be non-combustible.

Step 2

INSTALL FIREPLACE AND VENTING, RUN GAS AND ELECTRICAL

- ☑ Install the fireplace and venting. This must be completed by an authorized Ortal dealer (unless otherwise authorized by Ortal with written approval).
- ☑ Move the gas valve and receiver unit to the designated access panel location. If the fireplace will not have an access panel, keep gas valve and receiver unit directly underneath the fireplace.
- ☑ Run gas and electric to the gas valve and receiver unit location.

Step 3

BUILD FRONT WALL

- ☑ Install front chase wall:
 - Build front wall according to framing requirements.
 - Stand up the front wall and move into place.
 - Secure front wall to the rest of the chase structure.
- ☑ Cover the exterior of each wall (sides and front, and back if applicable depending on your design) with 5/8" Type X Drywall (or equivalent) and seal gaps with a non-combustible fire sealant.



NOTE: 5/8" Type X Drywall (or equivalent) is not required on the exterior portion of an insulated outside-facing wall.

- ☑ Check to make sure constructed chase meets heat release and air intake (if applicable) requirements.

Step 4

APPLY FINISHES

- ☑ Apply finishes and install accessories, following all clearances and building requirements.
- ☑ Ensure furniture and other combustible materials maintain a minimum 40 inches of clearance directly in front of the fireplace viewing area for both front and side viewing areas (as applicable).

Finishing

The following diagrams show various finish applications.



IMPORTANT NOTES:



- All recessed installations must comply with applicable maximum overhang limit and side wall clearances. See “Maximum Overhang Depth” and “Clearance to a Side Wall” sections for details.
- No material is permitted to extend past the ½” metal lip surrounding the fireplace viewing area. This area must be unobstructed to allow the heat barrier and inside glass panel to be removable.

Non-Combustible Finish

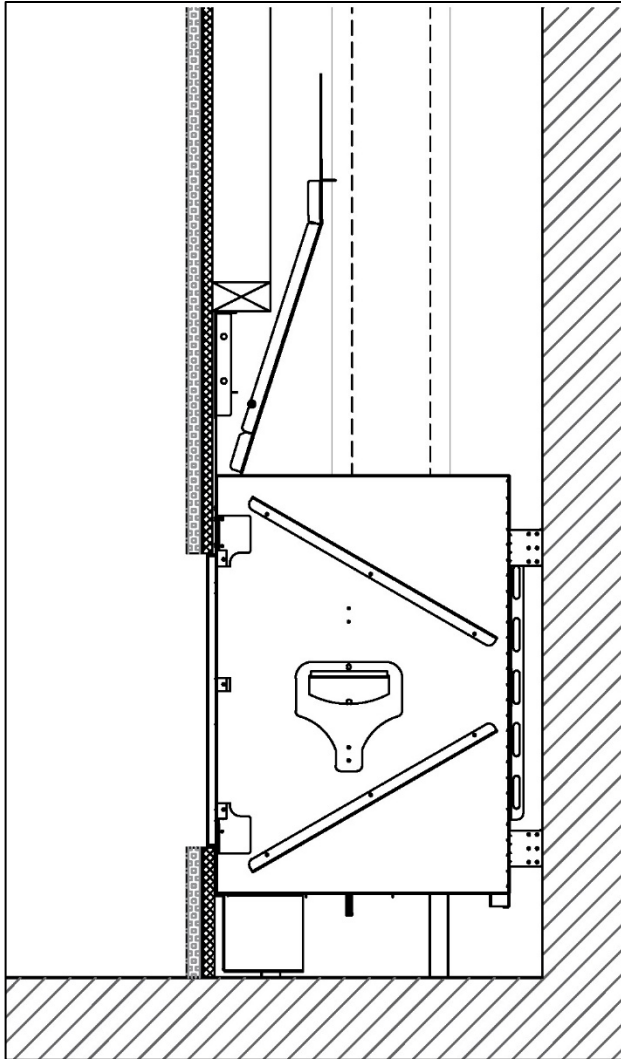
Flush Installation



LEGEND

-  5/8" Type X Drywall
-  Non-Combustible Finish



NOTES:

- 5/8" DensGlass® Fireguard® Sheathing is an approved 5/8" Type X Drywall equivalent. This may be necessary for use with heavier finishes.
- For manufactured stone products, a minimum 2-inch recess is recommended. Consult with the stone manufacturer for clearance requirements.
- Natural stone finishes do not require a recessed application and may be flush with the fireplace.

Recessed Installation

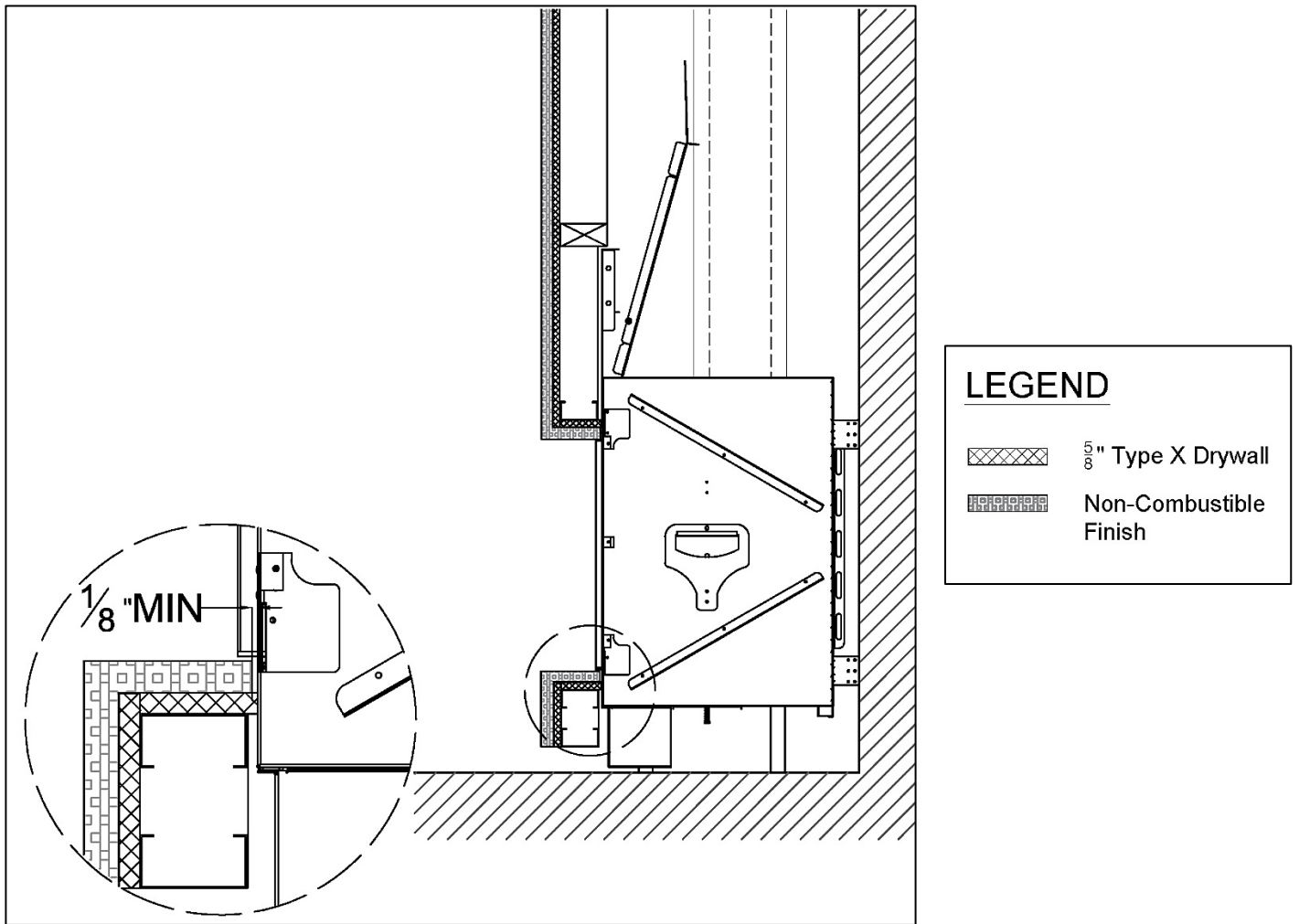

The finish must maintain at least a 1/8" clearance to the fireplace.

! **MANUFACTURED STONE:** A minimum 2-inch recess is suggested. Consult stone manufacturer for clearance requirements.

! **NOTE:** 5/8" DensGlass® Fireguard® Sheathing is an approved 5/8" Type X Drywall equivalent. This may be necessary for use with heavier finishes.

Combustible Finish

Flush Installation

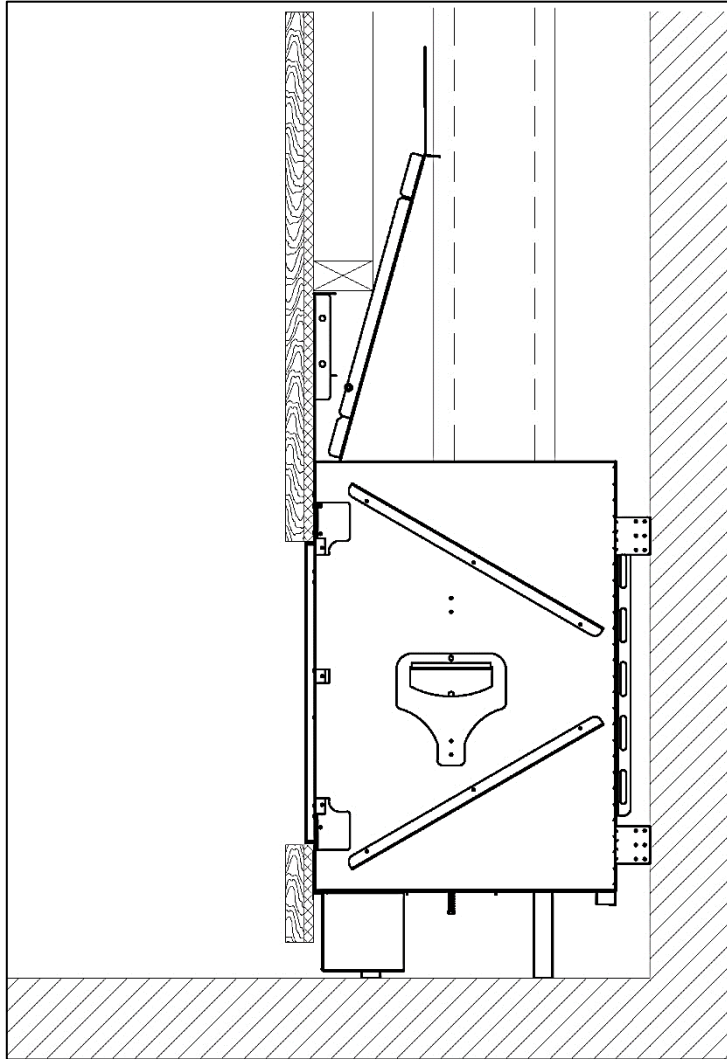

LEGEND

 5/8" Type X Drywall

 Combustible Finish

Recessed Installation

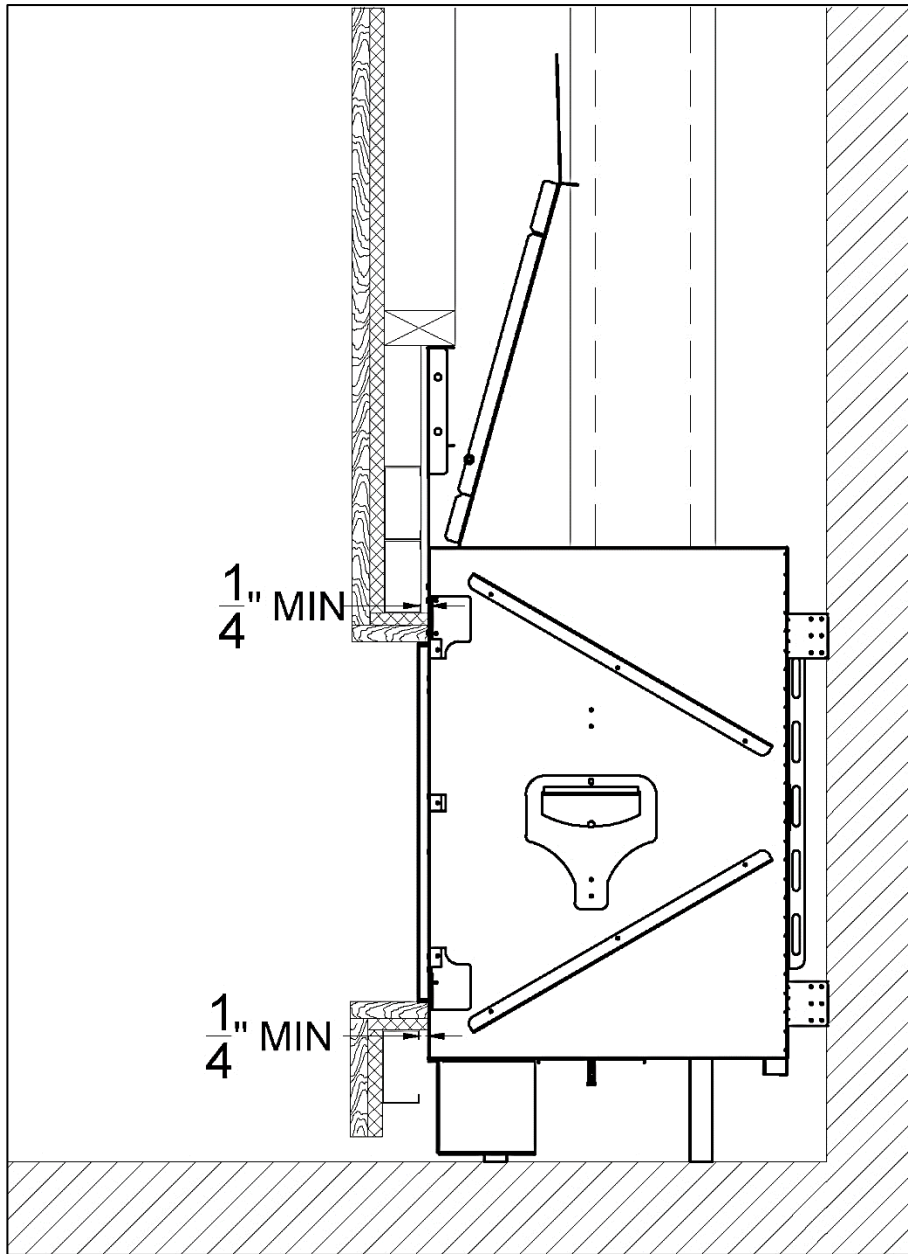



LEGEND

-  5/8" Type X Drywall
-  Combustible Finish

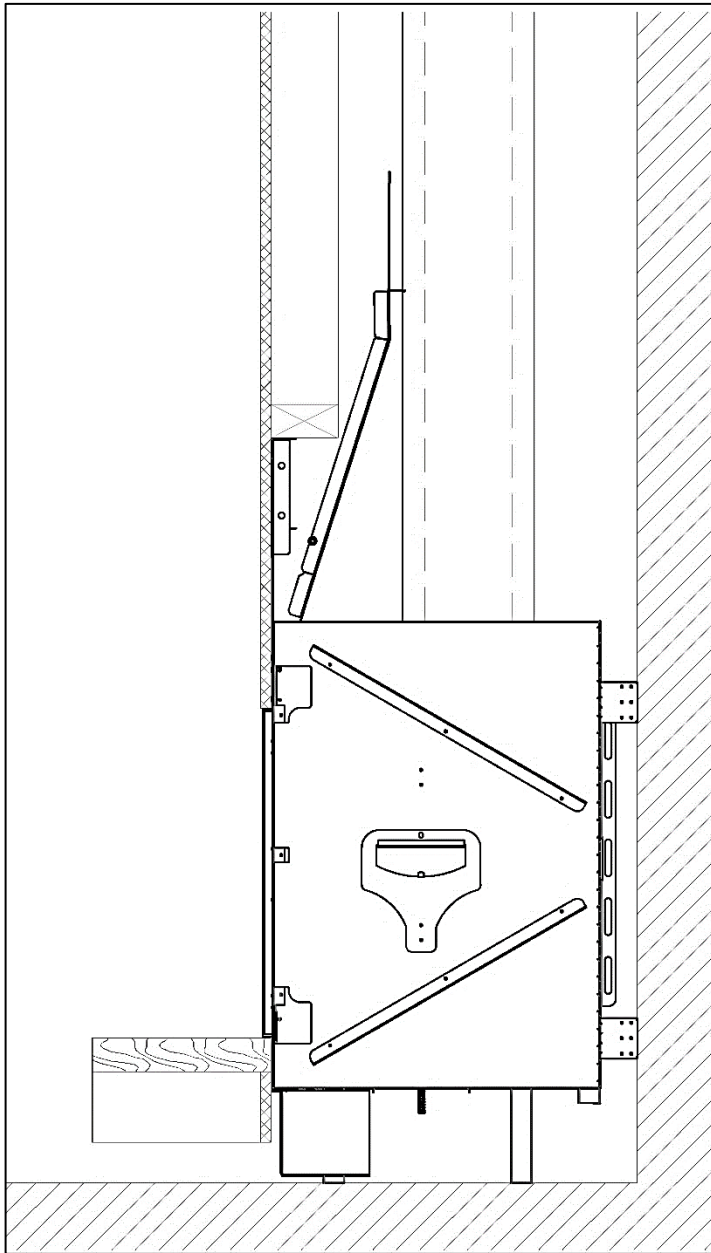
Combustible Floor/Hearth



LEGEND

-  5/8" Type X Drywall
-  Combustible Finish
-  Combustible Framing

 **WARNING:** Wood floor/hearth extension may dry out, crack, warp or become discolored over time. Consult with floor manufacturer for required clearances to a heat source.

Venting

General Venting Requirements

The fireplace operates using a direct vent system and require a co-axial direct vent pipe. The fireplace must be properly connected to an approved vent system. Venting is not provided with the fireplace and must be sourced from one of the approved vent manufacturers mentioned in the table below. Proper installation, use, and maintenance of venting is determined by and can be acquired from the vent manufacturer.

Vent Requirements			
Fireplace Series	Vent Type	Vent Size	Approved Vent Manufacturers
Wilderness 44H	Direct Vent	5x8 co-axial direct vent pipe (5" interior, 8" exterior)	Olympia: Ventis DuraVent: Direct Vent Pro ICC: EXCELDirect BDM: Pro-Form Direct Vent System Selkirk: Direct-Temp System
	Energex Power Vent		
	Ortal Power Vent*	3x5 co-axial direct vent pipe (3" interior, 5" exterior)	DuraVent: CVS line

Power Vent: a fan-assisted direct vent system that boosts airflow for vent configurations with too much constriction. Review “Vent Configuration Diagrams” section to determine if your fireplace needs a power vent.

 **NOTE:** See the Ortal Power Vent Manual for more details on power venting.

 **WARNING:** Do not combine vent components from different vent manufacturers. Please follow the manufacturer’s instructions for vent system installation.

Vent Installation

Venting must be installed to meet the requirements as detailed in the following sections in conjunction with the vent system manufacturer’s installation instructions. Venting must be supported by the structural surrounding and not by the fireplace. Each offset (elbow) must be strapped to reduce movement or possible disconnection.

The first section of venting must be secured to the fireplace starter collar with a minimum of 3 sheet metal screws no longer than ½”. DO NOT use silicone to seal the sections. If sealing is required by the vent manufacturer or local code, use Mil-Pac sealant.

 **WARNING:** Do not combine vent components from different vent manufacturers. Please follow the manufacturer’s instructions for vent system installation.

Vent Clearances

The following clearances apply to the vent system regardless of vent manufacturer.

Vent Clearances	
Sides: 1"	Applies to entire circumference when venting is oriented vertically. Clearance is to any material.
Top: 3"	Applies to venting oriented horizontally or at an angle. Clearance is to any material.
Bottom: 1"	

Minimum Vertical Rise (V minimum)		
Wilderness 44H	3 feet	Required from the top of the fireplace before any offset can be used*

*See "Offset Maximum Exception" below.

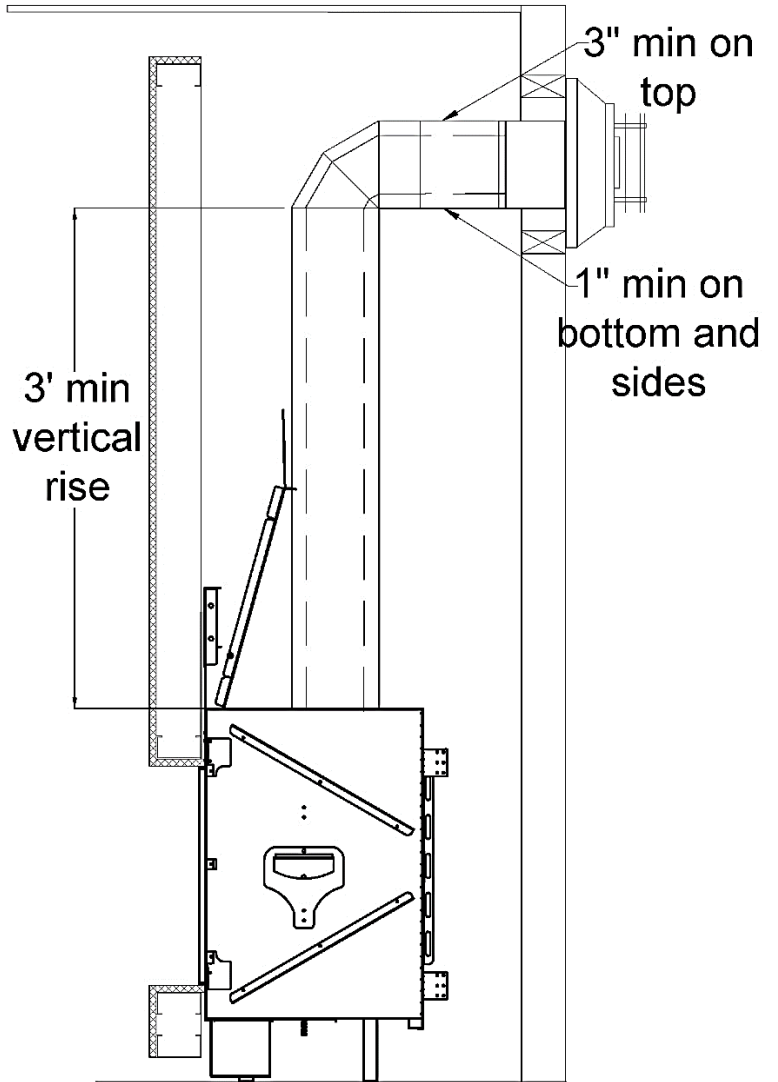

Offset Maximum

Up to 180° of offset (elbows) can be used in the vent configuration. If the vent configuration exceeds this maximum, consider an Ortal Power Vent System, which can allow for up to 540° of offset. See the Ortal Power Vent Manual for details.

Offset Maximum Exception

Two 45° offsets may be used directly on the fireplace with up to a 12" section between them. The minimum vertical rise starts above them. They do not count in the offset total.

! NOTE: If the initial vertical vent rise off the top of the fireplace does not meet the V minimum, consider an Ortal Power Vent System, which can allow for any initial vertical rise amount. See the Ortal Power Vent Manual for details.

Vent Configuration Diagrams

The following sections provide information for calculating vent configuration distances. For vent configurations that exceed these maximums, consider Ortal's Power Vent System. See the Ortal Power Vent Manual for details.

NOTE: It is not required to maintain ¼" of rise per foot of venting.

Horizontal Termination Venting Diagram

Use this diagram and tables below to calculate distances for vent configurations that terminate horizontally.

V minimum = 3 feet.

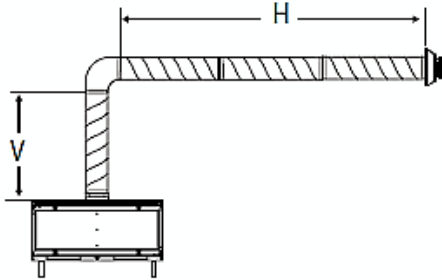

Vertical (V)	Max Horizontal (H)
3 ft	12 ft
6 ft	18 ft
9 ft	24 ft
12 ft	21 ft
15 ft	21 ft
18 ft	18 ft
21 ft	15 ft
24 ft	12 ft
27 ft	12 ft
30 ft	12 ft
33 ft	12 ft

Vertical Termination Venting Diagram

Use this diagram and tables below to calculate distances for vent configurations that jog and terminate vertically.

V1 minimum = 3 feet. V = V1 + V2

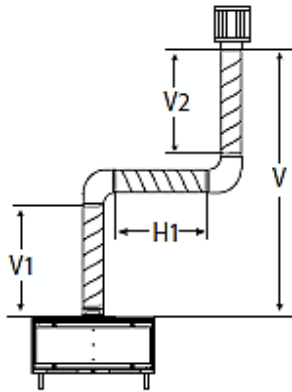

Vertical (V)	Max Horizontal (H1)
3 ft	6 ft
7 ft	15 ft
10 ft	18 ft
13 ft	15 ft
16 ft	15 ft
19 ft	12 ft
22 ft	9 ft
25 ft	6 ft
28 ft	6 ft
31 ft	6 ft
34 ft	6 ft

Vertical Termination Venting Diagram

Use this diagram and tables below to calculate distances for vent configurations vent and terminate vertically.

V minimum = 3 feet.

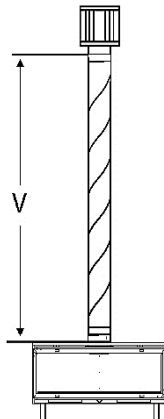

Vertical (V)	Max Horizontal (H)
44 ft	N/A

Vent Restrictor Sizing Guidelines

SCENARIO A

The vent configuration has two vertical 45° offsets. No additional length for the (H) calculation for the restrictor plate size is needed.

For example:

Total height of duct work = 6 feet (V)

Length between the center of the two 45° elbows = (B) = 3 feet

The (H) calculation is $(H) = (B)$ so the restrictor plate size is 1.97", per the table.

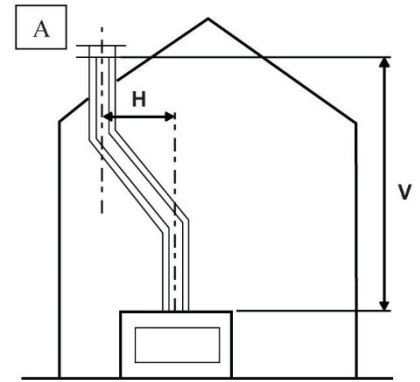

SCENARIO B

The vent configuration has two 90° offsets. An additional 6 feet must be added to the (H) calculation for the restrictor plate size.

For example:

Total height of duct work = 18 feet (V)

Length between the center of two 90° elbows = (B) = 21 feet

The (H) calculation to be used in the restrictor table is $(H) = (B) + 6$ feet, so the (H) length is 27 feet.

Per the table, the restrictor plate is 0. No restrictor is required.

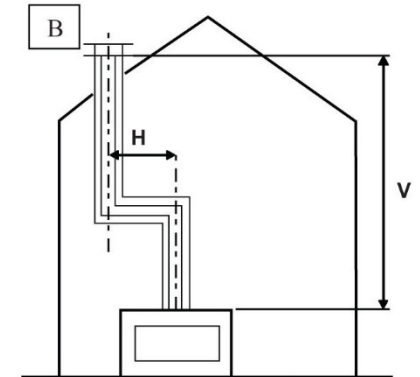

SCENARIO C

The vent configuration has one 90° offset. The first 90° offset is not taken into calculation of the (H) length for the restrictor plate size.

For example:

Total height of duct work = 15 feet (V)

Length between the center of the 90° elbow and wall termination cap = (B) = 11 feet

The (H) calculation is $(H) = (B) = 11$. Therefore, the restrictor plate size is 1.18", per the table.

The value of 11 does not appear on the x scale of the table. The choices are then 9 and 12. Always choose the next **higher** value, which is also the smaller restrictor if there is a difference between the values provided.

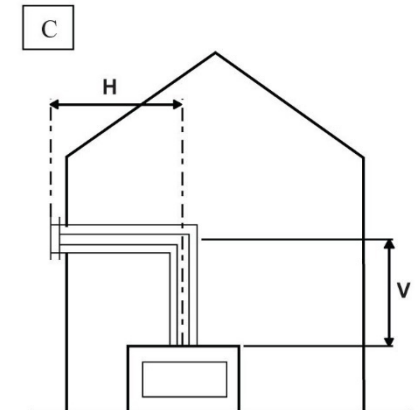

SCENARIO D

The vent configuration is straight vertical (no 45° or 90° offsets).

For example:

Total height of duct work = 24 feet (V)

The (H) calculation is = 0. Therefore, the restrictor plate size is 1.97".

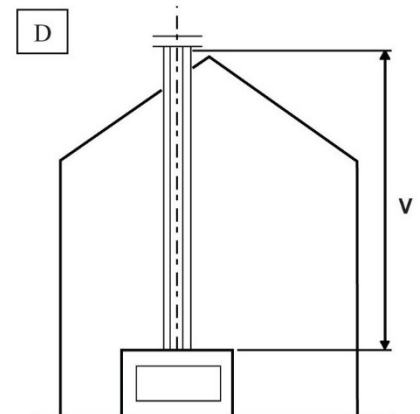

Restrictors and Vent Configuration

The information in this section will help you calculate the correct restrictor selection for your vent configuration. The table below show the restrictor required for a specific rise to run vent configuration. Any venting pathway that does not appear in the tables requires approval from the manufacturer.

The table below applies to both Natural Gas and Propane. This table represents manufacturer's guidelines. Environment, gas type and other factors may affect the best restrictor choice.

How to use the "Recommended Restrictor" table:

1. Find the total vertical rise in your vent configuration along the y-axis.
2. Find the horizontal run in your vent configuration along the x-axis.
3. Follow the rise and run values on the chart until they meet. This is the recommended size restrictor for your vent configuration.

Legend:

X: Vent configuration is not allowed.

0: No restrictor required.

Numbers other than 0: The number (in inches) represents the recommended restrictor (by width).

Total Vertical Vent Rise (in feet)	Horizontal Vent Run (in feet)											
	0'	3'	6'	9'	12'	15'	18'	21'	24'	27'	30'	33'
27'	1.97"	1.97"	1.97"	1.97"	1.57"	1.18"	1.18"	x	x	x	x	x
24'	1.97"	1.97"	1.97"	1.57"	1.18"	1.18"	1.18"	0	x	x	x	x
21'	1.97"	1.97"	1.97"	1.57"	1.18"	1.18"	1.18"	0	0	x	x	x
18'	1.97"	1.97"	1.97"	1.57"	1.18"	1.18"	1.18"	0	0	0	x	x
15'	1.97"	1.97"	1.57"	1.57"	1.18"	1.18"	1.18"	x	0	0	0	x
12'	1.57"	1.57"	1.57"	1.57"	1.18"	1.18"	1.18"	x	0	0	0	x
9'	1.57"	1.57"	1.57"	1.18"	x	x	x	x	0	0	0	x
6'	x	x	x	x	x	x	x	x	0	0	x	x
3'	x	x	x	x	x	0	0	0	0	x	x	x

Vent Termination

Horizontal Termination Clearance Diagram

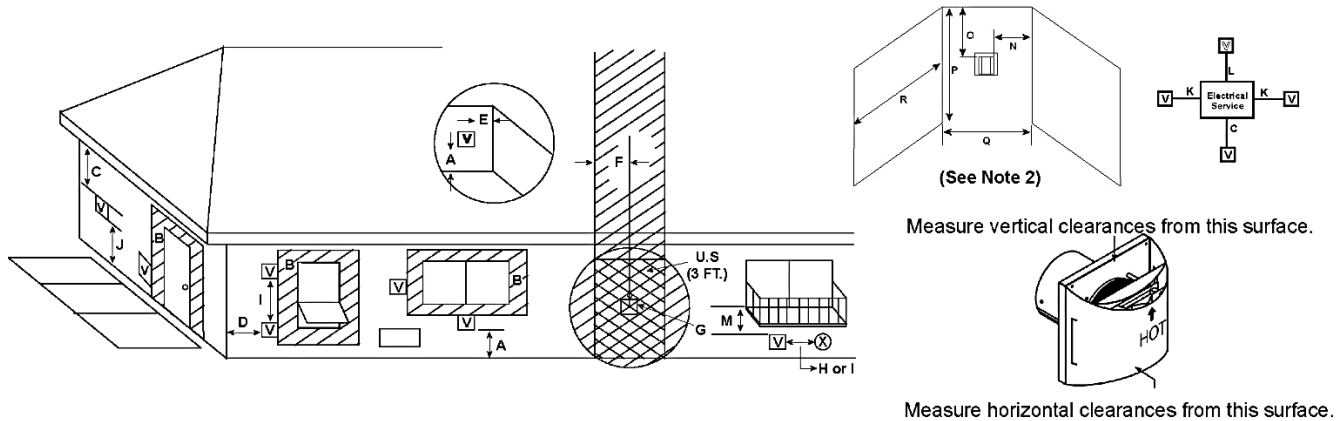

V = VENT TERMINAL **X** = AIR SUPPLY INLET **▨** = AREA WHERE TERMINAL IS NOT PERMITTED

A = 12 inches.....clearances above grade, veranda, porch, deck or balcony (See Note 1)	J** = 7 ft..... clearance above paved sidewalk or a paved driveway located on public property (See Note 1)																			
B = 12 inches.....clearances to window or door that may be opened, or to permanently closed window. (Glass)	K = 6 inches.....clearance from sides of electrical service (See Note 5)																			
C = 24 inches.....vertical clearance to ventilated soffit located above the terminal 18 inches.....vertical clearance to unventilated soffit located above the terminal 42 inches.....for vinyl clad soffits and below electrical service	L = 12 inches.....clearance above electrical service (See Note 5)																			
D = 9 inches.....clearance to outside corner	Covered Alcove Applications																			
E = 6 inches.....clearance to inside corner	M*** = 24 inches.....clearance under veranda, porch, deck, balcony or overhang 42 inches..... vinyl																			
F = 3 ft. (Canada).....not to be installed above a gas meter/regulator assembly within 3 feet (90 cm) horizontally from the center-line of the regulator	N = 6 inches..... non-vinyl sidewalls 12 inches..... vinyl sidewalls																			
G = 3 ft.....clearance to gas service regulator vent outlet	O = 24 inches..... non-vinyl soffit and overhang 42 inches..... vinyl soffit and overhang																			
H = 9 inches (U.S.A.) 12 inches (Canada) clearance to non-mechanical air supply inlet to building or the combustion air inlet to any other appliance (See Note 2)	P = 8 ft.																			
i = 3 ft. (U.S.A.) 6 ft. (Canada).....clearance to a mechanical (powered) air supply inlet (See Note 2)	<table border="1"> <thead> <tr> <th></th> <th>Q_{MIN}</th> <th>R_{MAX}</th> </tr> </thead> <tbody> <tr> <td>1 cap</td> <td>3 feet</td> <td>2 x Q_{ACTUAL}</td> </tr> <tr> <td>2 caps</td> <td>6 feet</td> <td>1 x Q_{ACTUAL}</td> </tr> <tr> <td>3 caps</td> <td>9 feet</td> <td>2/3 x Q_{ACTUAL}</td> </tr> <tr> <td>4 caps</td> <td>12 feet</td> <td>1/2 x Q_{ACTUAL}</td> </tr> <tr> <td colspan="3">Q_{MIN} = # termination caps x 3 R_{MAX} = (2 / # termination caps) x Q_{ACTUAL}</td> </tr> </tbody> </table>			Q _{MIN}	R _{MAX}	1 cap	3 feet	2 x Q _{ACTUAL}	2 caps	6 feet	1 x Q _{ACTUAL}	3 caps	9 feet	2/3 x Q _{ACTUAL}	4 caps	12 feet	1/2 x Q _{ACTUAL}	Q _{MIN} = # termination caps x 3 R _{MAX} = (2 / # termination caps) x Q _{ACTUAL}		
	Q _{MIN}	R _{MAX}																		
1 cap	3 feet	2 x Q _{ACTUAL}																		
2 caps	6 feet	1 x Q _{ACTUAL}																		
3 caps	9 feet	2/3 x Q _{ACTUAL}																		
4 caps	12 feet	1/2 x Q _{ACTUAL}																		
Q _{MIN} = # termination caps x 3 R _{MAX} = (2 / # termination caps) x Q _{ACTUAL}																				

** a vent shall not terminate directly above a sidewalk or paved driveway which is located between two single family dwellings and serves both dwellings.

*** only permitted if veranda, porch, deck or balcony is fully open on a minimum of 2 sides beneath the floor, or meets Note 2.

Note 1: On private property where termination is less than 7 feet above a sidewalk, driveway, deck, porch, veranda or balcony, use of a listed cap shield is suggested. (See vents components page)

Note 2: Termination in a covered alcove space (spaces open only on one side and with an overhang) are permitted with the dimensions specified for vinyl or non vinyl siding and soffits. 1. There must be 3 feet minimum between termination caps. 2. All mechanical air intakes within 10 feet of a termination cap must be a minimum of 3 feet below the termination cap. 3. All gravity air intakes within 3 feet of a termination cap must be a minimum of 1 foot below the termination cap.

Note 3: Local codes or regulations may require different clearances.

Note 4: Termination caps may be hot. Consider their proximity to doors or other traffic areas.

Note 5: Location of the vent termination must not interfere with access to the electrical service.

In the U.S and Canada: Vent system termination is NOT permitted in screened porches.

Vent system termination is permitted in porch areas with two or more sides open. You must follow all side walls, overhang and ground clearances as stated in the instructions.

! CAUTION NOTE: If exterior walls are finished with vinyl siding, it is required that a vinyl protector kit be installed.

Vertical Termination Clearance Diagram

Minimum Height From Roof To Lowest Discharge Opening

HORIZONTAL OVERHANG
24 INCHES MIN.
2 FT. MIN.
LOWEST DISCHARGE OPENING
VERTICAL WALL
GAS DIRECT VENT TERMINATION CAP
H
12 X
ROOF PITCH IS X/12 H
(MIN.) - MINIMUM HEIGHT FROM ROOF TO LOWEST DISCHARGE OPENING

Roof Pitch	H (Min.) Ft.
Flat to 6/12.....	1.0*
Over 6/12 to 7/12.....	1.25*
Over 7/12 to 8/12.....	1.5*
Over 8/12 to 9/12.....	2.0*
Over 9/12 to 10/12.....	2.5*
Over 10/12 to 11/12.....	3.25
Over 11/12 to 12/12.....	4.0
Over 12/12 to 14/12.....	5.0
Over 14/12 to 16/12.....	6.0
Over 16/12 to 18/12.....	7.0
Over 18/12 to 20/12.....	7.5
Over 20/12 to 21/12.....	8.0

*H min. may vary depending on regional snowfall. Refer to local codes.

Staggered Termination Caps

A	B
6 in. (minimum) up to 24 in.	18 in. minimum
24 in. and over	0 in. minimum

Gas, Wood or Fuel Oil Termination Cap
B
A*
Gas Termination Cap**

* if using decorative cap cover(s), this distance may need to be increased. Refer to the installation instructions supplied with the decorative cap cover.

** In a staggered installation with both gas and wood or fuel oil terminations, the wood or fuel oil termination cap must be higher than the gas termination cap.

Notes:

1. Maintain a minimum of 2 feet clearance between edge of vertical termination and perpendicular wall.
2. If terminating near window, keep minimum of 2 feet clearance between window and vent termination.
3. All mechanical air intakes (such as an Enervex power vent) within 10 feet of a termination cap must be a minimum of 3 feet below the termination cap.
4. All gravity air intakes within 3 feet of a termination cap must be a minimum of 1 foot below the termination cap.

! NOTE: This chart does not apply to a chimney shroud application. See the "Chimney Shroud" section on the next page for more information.

Chimney Shroud

Keep a minimum 6-inch clearance around the diameter of the cap's side edge and extending above and below the cap.

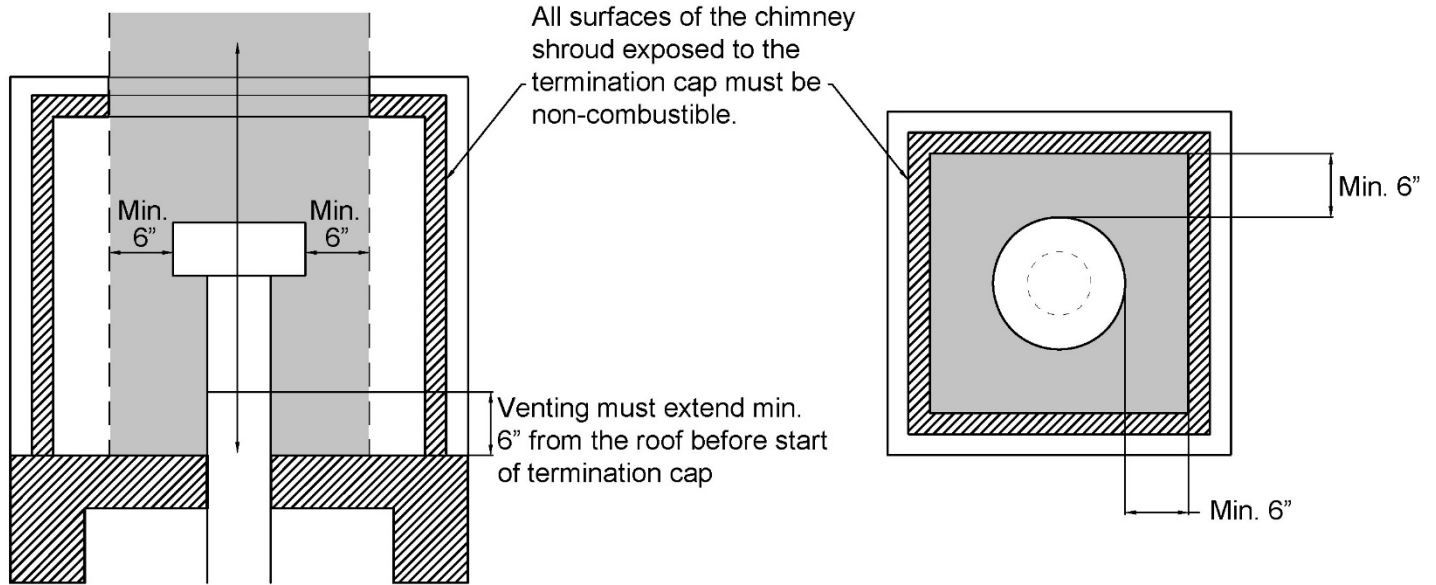

Vent Maintenance

Regular inspection of the vent system by a qualified service technician is recommended every six months. The following maintenance routing is recommended:

- Inspect for excessive condensation, e.g., water droplets forming in the inner lining, and subsequently dripping from the joints. This can cause corrosion in the system.
- Check for corrosion in areas exposed to the elements. Components with rust spots or holes must be immediately replaced.
- Ensure that there is no foreign material in the vents. Survey by removing the cap and shining a light down the vent.
- If possible, check all vent joints to make sure nothing has been disturbed or loosened.

Gas

The fireplaces are approved for use with natural gas (NG) or propane (LP) only. No other fuel types are permitted.

Gas Pressures

Fireplace Series	Burner	Electrical Requirements	Gas Type	Inlet Pressure		Manifold Pressure	Heat Input (BTU/hr)		Orifice Size (by log)
				Min	Max		Min	Max	
Wilderness 44H	Driftwood Log Set	Dedicated Outlet: 120v 15-amp 60hz	Natural Gas	7.0	11.0	4.7	15,686	32,163	320-160-320 380
			Propane	11.0	13.0	4.7	21,400	31,400	90-60-90 180

NOTE: It can take up to 20 minutes for the flames to turn yellow.

Routing the Gas Line

Correctly size and route the gas supply line from the supply regulator to the area where the access panel is located (or to the burner area if no access panel is available), as per the requirements outlined in the latest edition of the National Fuel Gas Code, NFPA 54 (USA) or CAN/CSA-B1491 (Canada).

The gas and electrical components are attached to the pilot on a flexible gas line and can be kept directly under the fireplace or moved to the side or back of the fireplace within 36 inches of the pilot (located at the center front of the burner). Gas line should be routed to the access panel area (see "Access Panel" section for details). If no access panel is planned, gas line should be routed to the most accessible area within the 36" radius (as shown in diagram below).

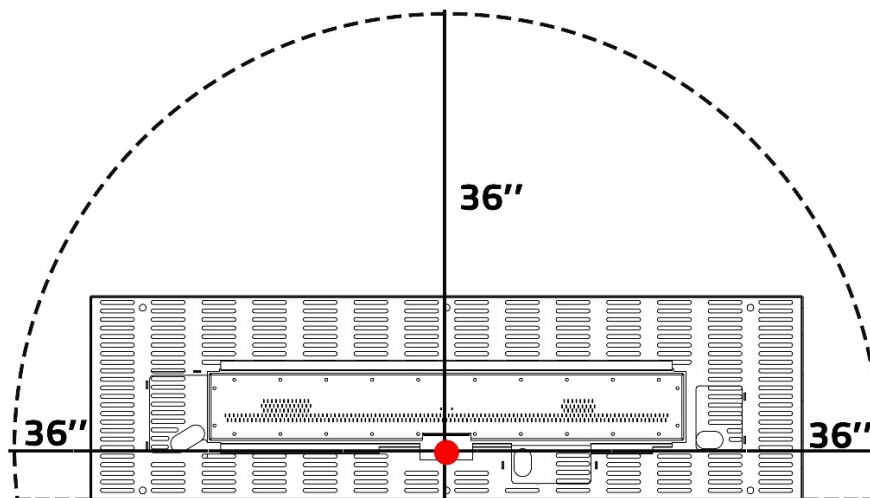

A gas shut-off valve and a 12" gas flex connector are provided with every fireplace. The location of the gas shut-off valve is dependent on local codes and requirements. Check with your authority having jurisdiction for more information.

WARNING –The main gas valve must be installed to allow complete disconnection of the fireplace from the gas supply piping system for servicing purposes.

Gas Conversion

Gas conversion (NG to LP or LP to NG) can be done in the field. Gas conversion must be performed only by technicians who have specific authorization by Ortal to change these components. The conversion kit must be supplied by Ortal. Using parts from other manufacturers or having an unauthorized party performing the conversion will void your fireplace's warranty. Conversion instructions are supplied with the conversion kit.

High Altitude Requirements

For elevations above 2,000 feet, fireplace shall be re-rated 4% for each 1,000 feet above sea level.

Gas and Electrical Components

Assemblies and components are listed and described in the tables following the figure.

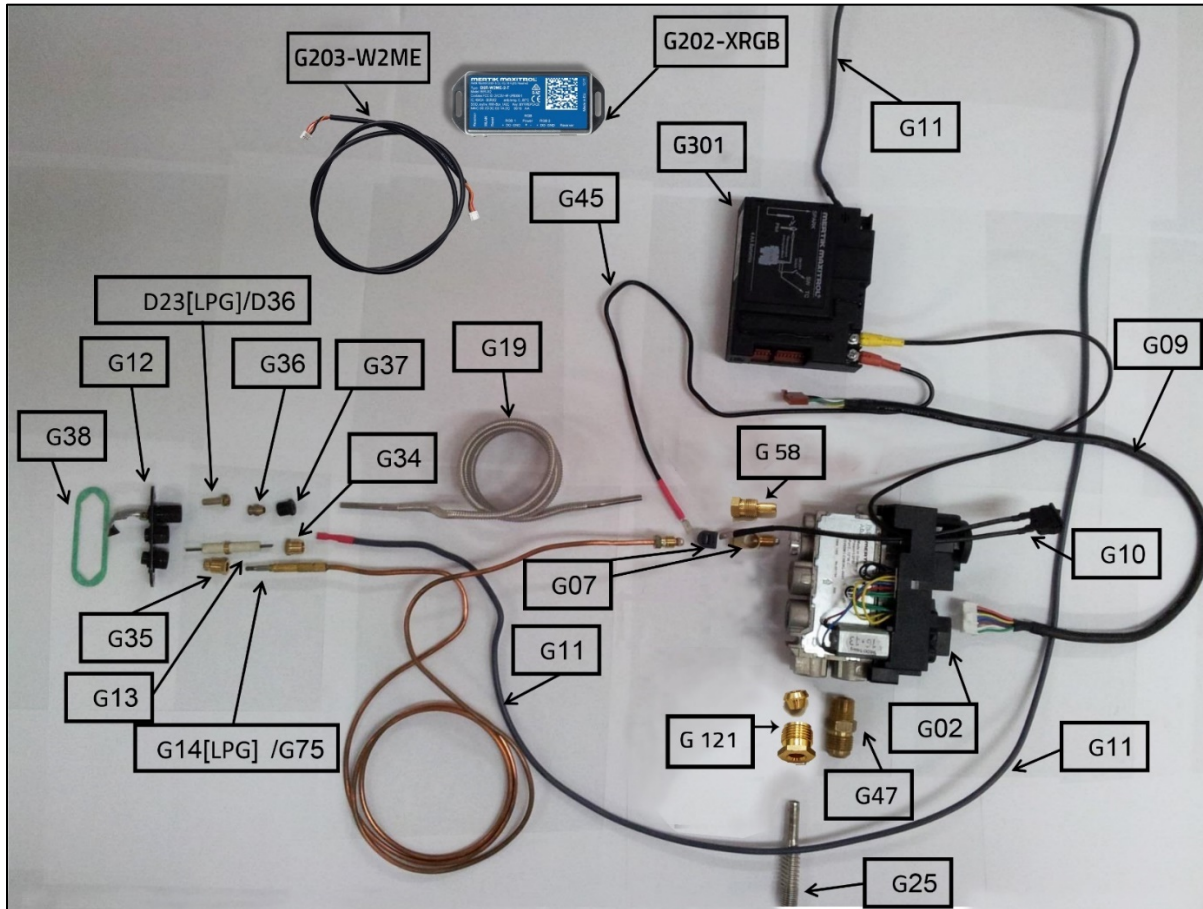

Part Number	Description
D23	Orifice LPG
D36	Orifice NG
G02	Mertik Gas Valve
G301	Symax Receiver
G202-XRGB	Symax Wi-Fi Box
G203-W2ME	Symax Wi-Fi Box Cable
G07	Thermocouple Block
G09	Wire Harness for Receiver and Gas Valve
G10	Switch w. cables 180/500 mm
G11	Spark Wire
G12	Pilot Base
G75	Thermocouple NG
G14	Thermocouple LPG

Part Number	Description
G13	Electrode Target Type
G121	Main Burner Gas Fitting
G25	Burner Gas Tube
G19	Pilot Gas Tube
G34	Spark Plug Connector
G35	Thermocouple Connector
G36	OLIVE D.4 Pilot gas tube compression ring valve
G37	Pilot gas tube fitting burner side
G38	Pilot Assembly Gasket
G45	Red Cable
G58	Connection fitting 4mm One-piece
G47	Fitting for main line inlet to gas valve GV60

The manufacturer of Ortal's gas and electrical components is Mertik Maxitrol. For information on these components, please visit the manufacturer's website: www.mertikmaxitrol.com

Electrical

 **WARNING:** Disconnect the power supply before servicing any electrical components.

Electrical Requirements

The fireplace is supplied with a 120V AC Adapter to connect the fireplace electrical receiver unit to a single gang outlet (120V, 15 amp, 60Hz). AC Adapter is required for operation.

Outlet must be installed in the location where the gas and electrical components will be placed, which must be to the side or back of the fireplace within **36 inches** of the pilot (see diagram in “Routing the Gas Line” section). Electrical work should be performed by a qualified licensed electrician, per local code.

 **WARNING:** Use of an AC Adapter other than the one provided with the fireplace (manufactured by Mertik Maxitrol) may render the system inoperable.

 **NOTE:** Any device that functions using the same radio frequency as the handset will be affected when remote-controlled handset is in use.

Pairing the Remote and Receiver

To set up the remote-control device to operate the fireplace, follow the following guidelines to pair the remote and receiver unit on the same radio frequency.

1. Press and hold the receiver’s reset button until you hear two beeps. The first beep is short, and the second beep is long. After the second beep, release the reset button.



2. Within the subsequent 20 seconds, press the following button depending on the mode of operation:
 - **10-Button Handset:** Press the  button. “CONN” and a running number from 1 to 8 will appear on the handset display confirming that the synchronization and data exchange are in process.
 - **Wall Switch:** Use the 10-button handset to synch with the receiver. Once the remote and receiver are paired, the wall switch will function normally.
 - **myFire App:** Use the 10-button handset to synch with the receiver. Once the remote and receiver are paired, the App will function normally.
3. You will hear two short beeps confirming the connection.

 **NOTES:**

- If you hear one long beep, this indicates the connection has failed or the wiring is incorrect.
- The connection between remote and receiver only needs to be made once and is not required after changing the batteries in the remote.

Wiring Diagrams

The following diagrams show the electrical wiring required for different feature combinations.

Wiring Diagram: Screen Fireplace with Interior Lighting

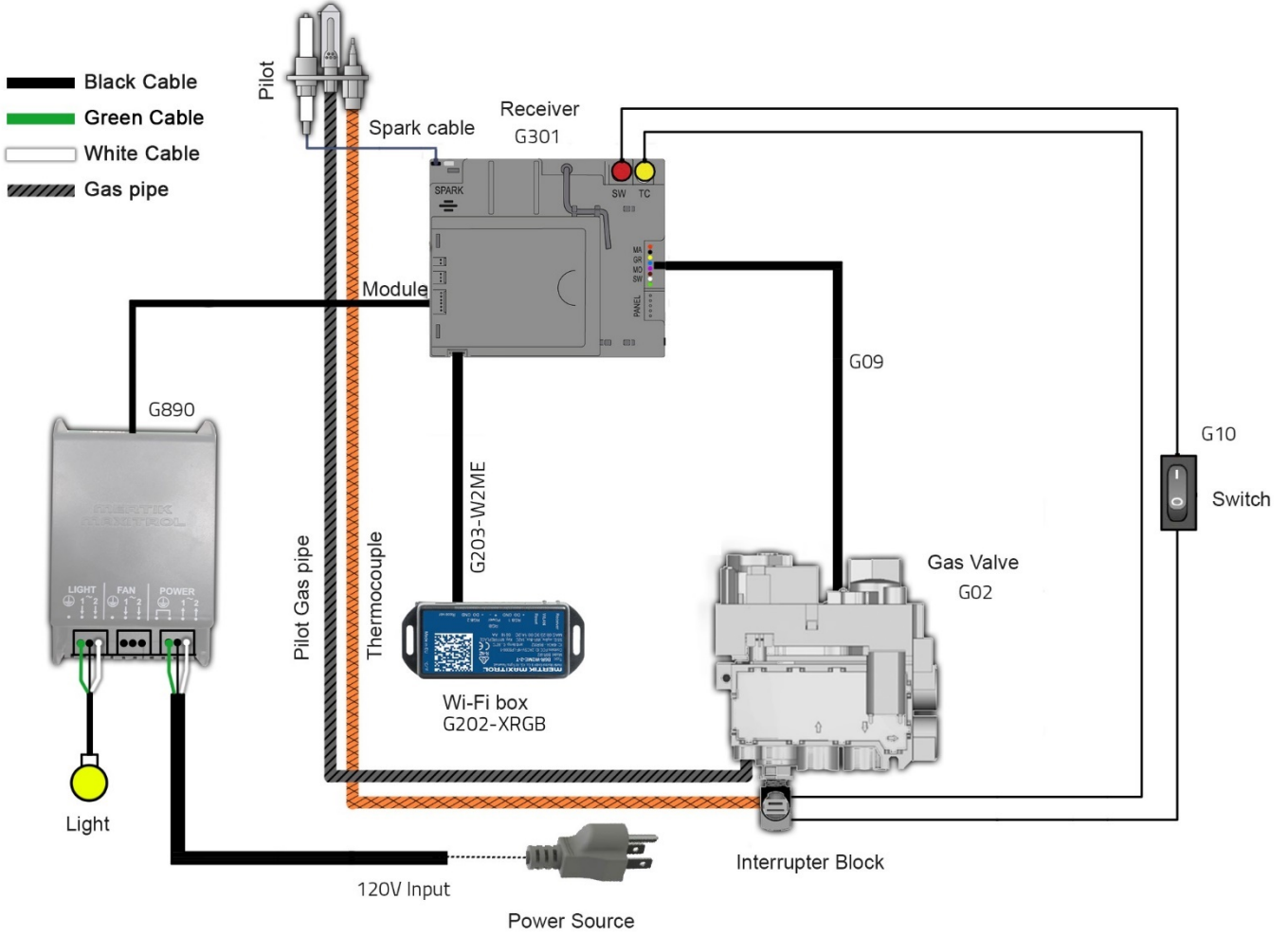

Wiring Diagram: Screen Fireplace with Interior Lighting and Ortal Power Vent

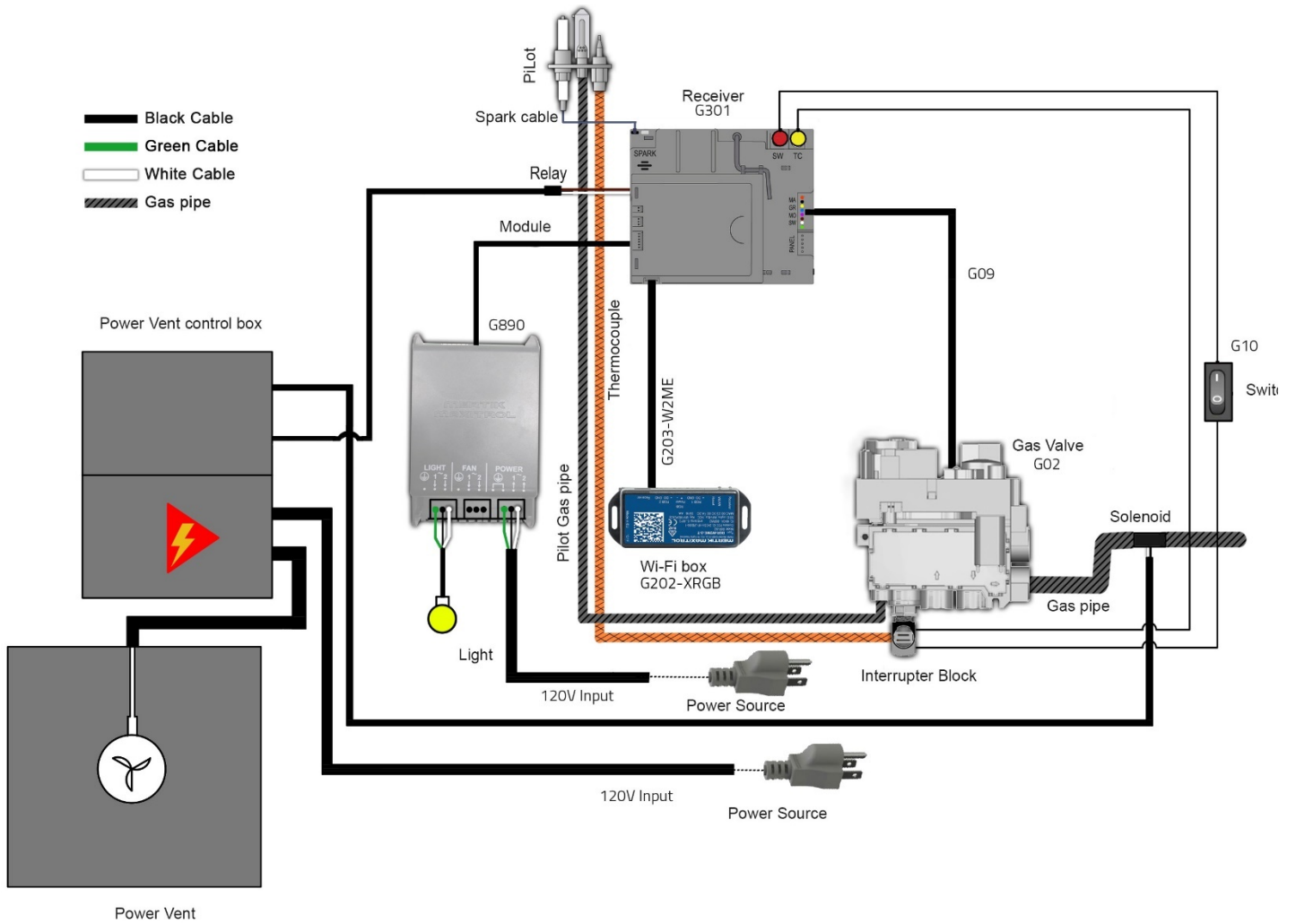

Wiring Diagram: Double Glass Fireplace with Interior Lighting

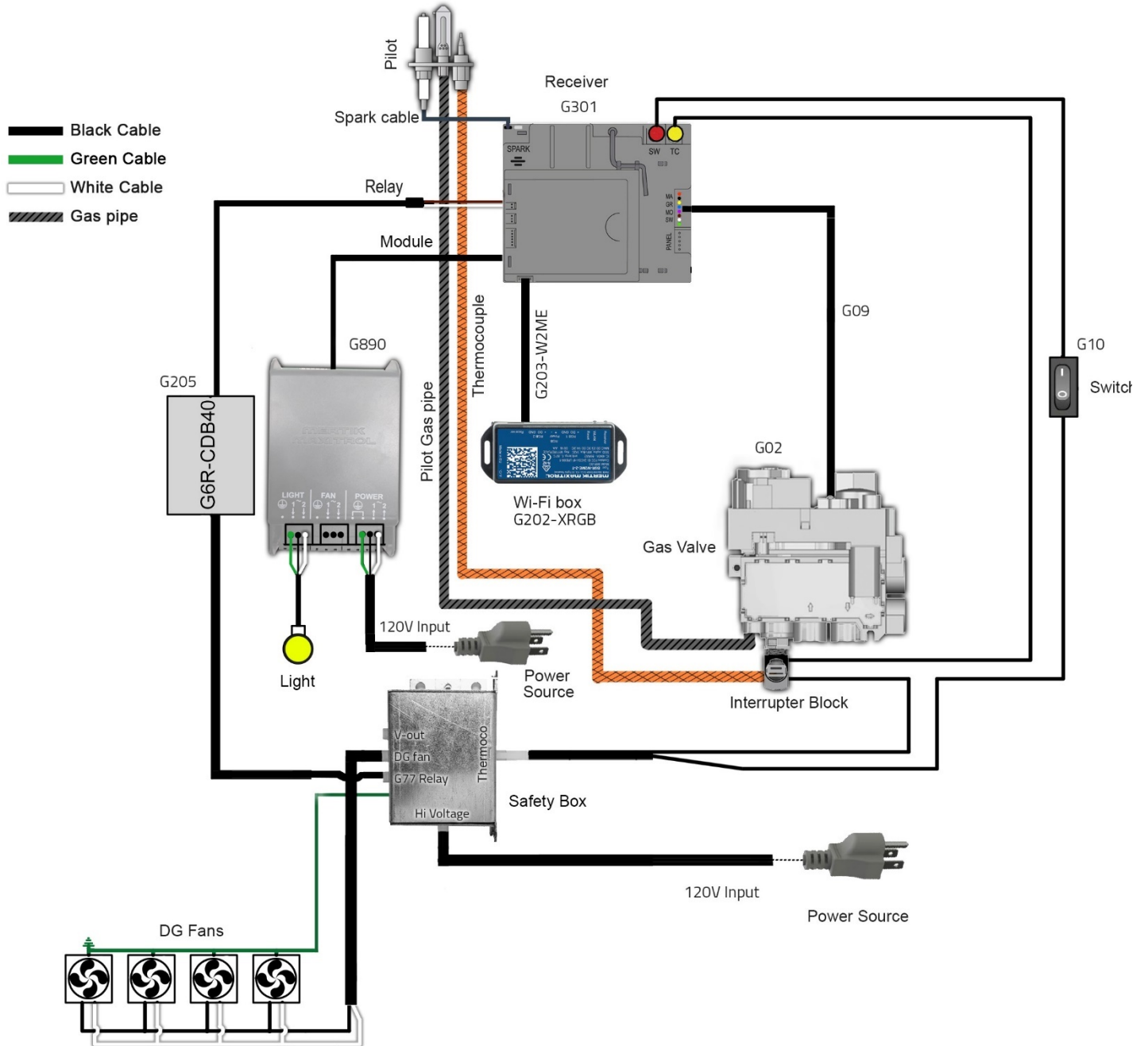

Wiring Diagram: Double Glass Fireplace with Interior Lighting and Ortal Power Vent

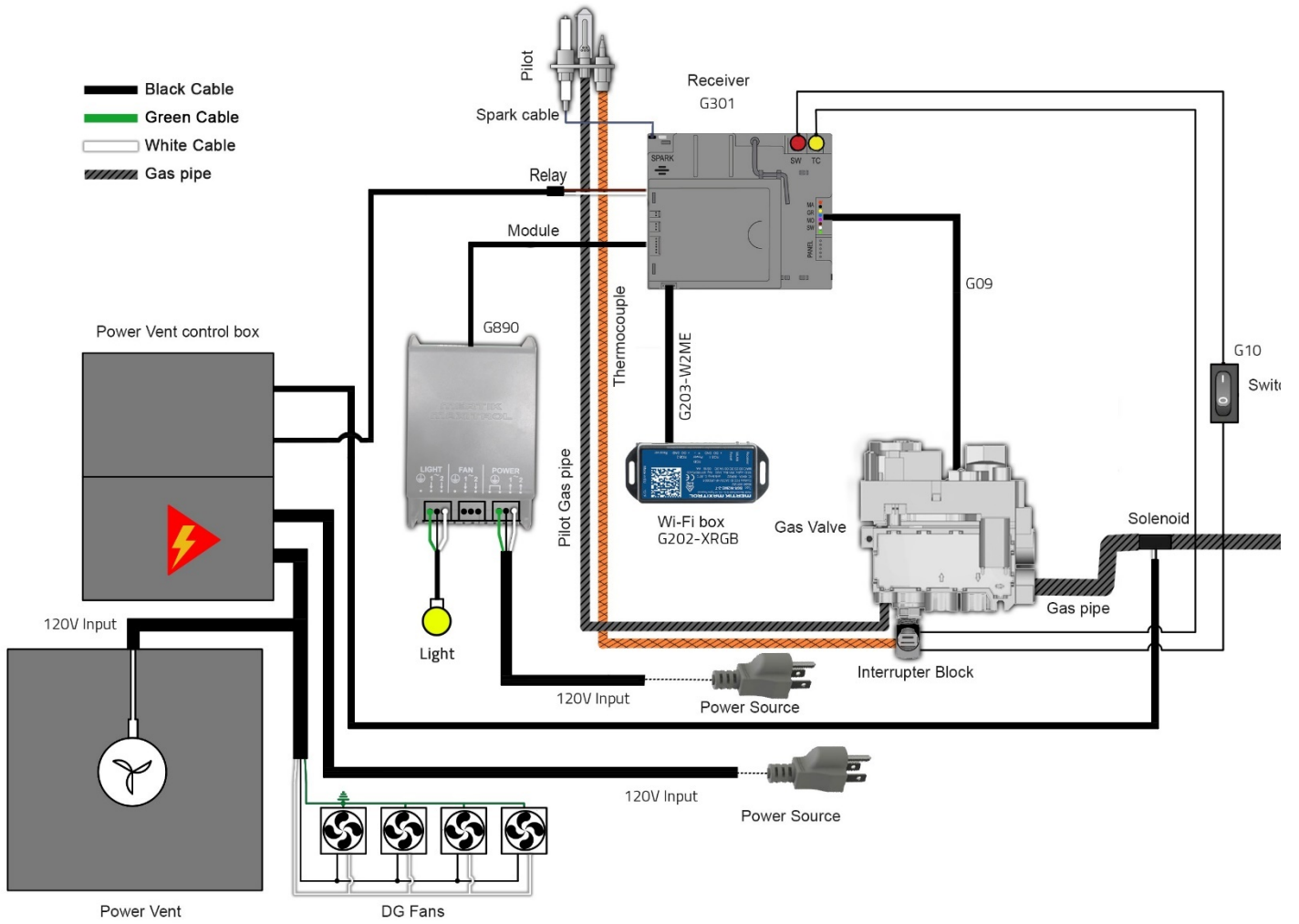

Carbon Monoxide Detector Wiring Diagrams

CO Kit Wiring Diagram: Screen Fireplace

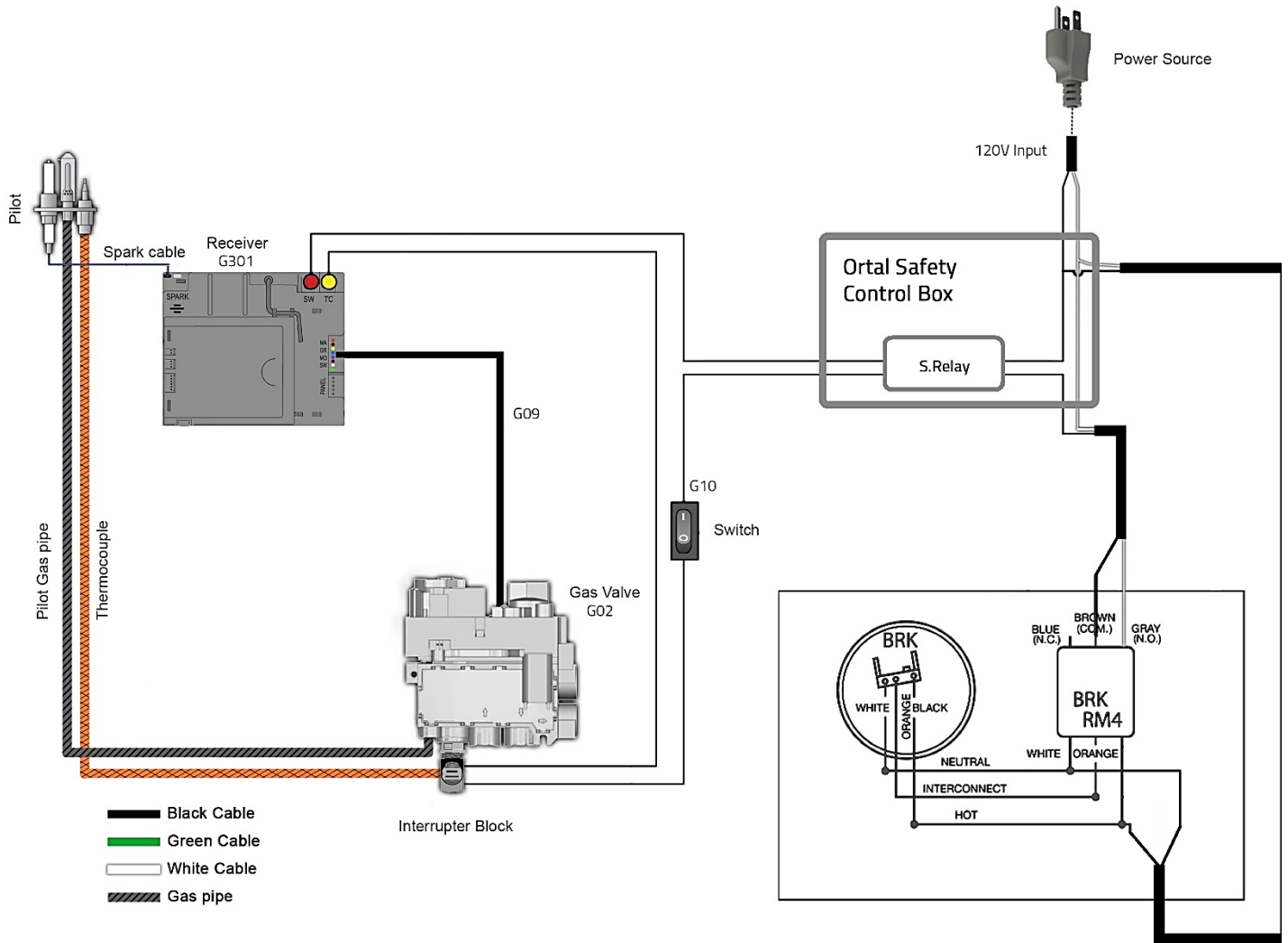

CO Kit Wiring Diagram: Double Glass Fireplace

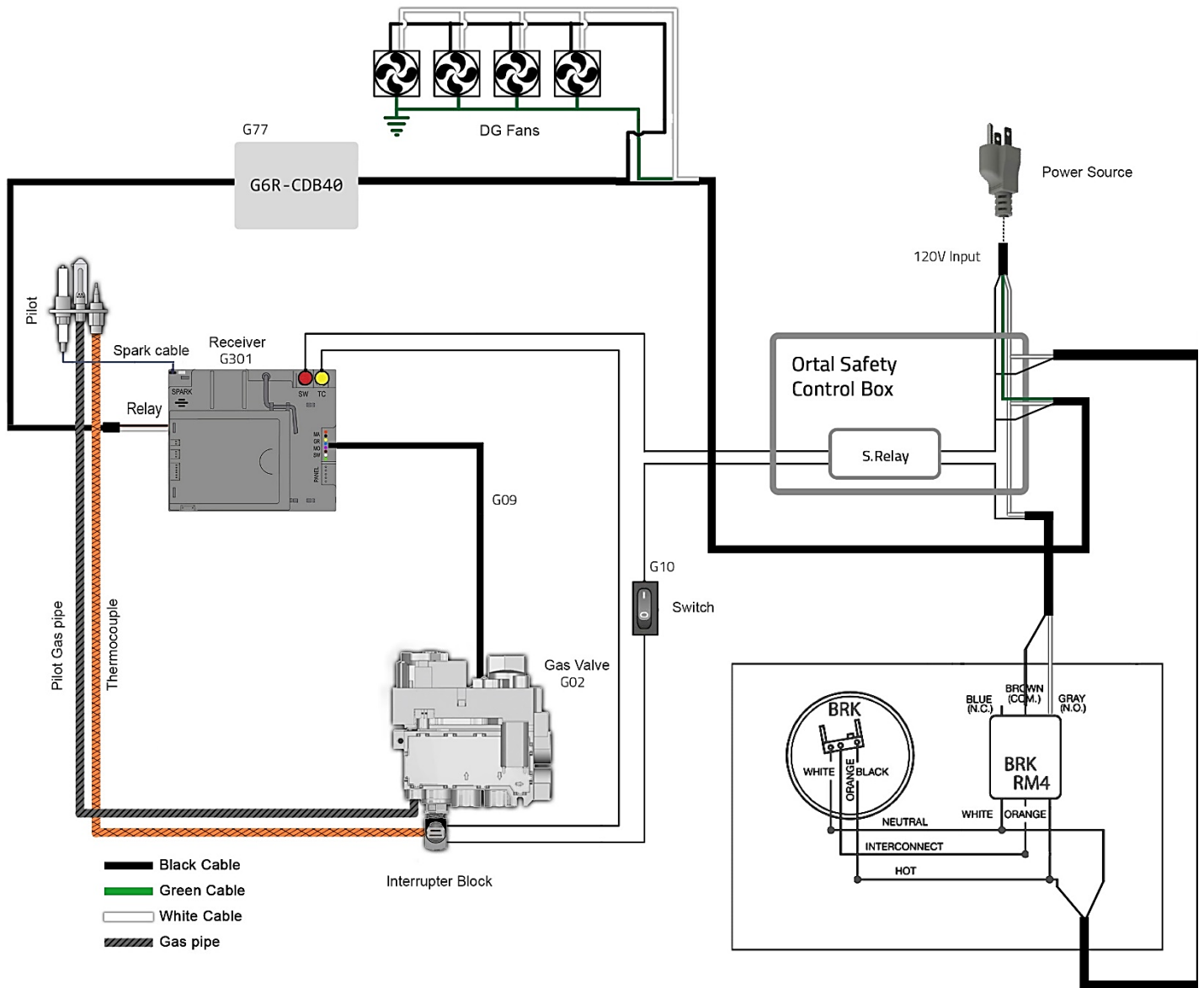

Smart Home Wiring Diagram

Use the following wiring diagram to connect fireplace control a hardwired smart home system.

Contacts Options/Operation

Ignition: Close contact 1 and 3 simultaneously for 1 second. Fireplace automatically goes to high after ignition.
Up Flame: Close contact 1. The contact needs to be closed for 12 seconds to turn the motor from end-stop to end-stop.
Down Flame: Close contact 3. The contact needs to be closed for 12 seconds to turn the motor from end-stop to end-stop.
Off: Close contacts 1, 2, and 3 simultaneously for 1 second.

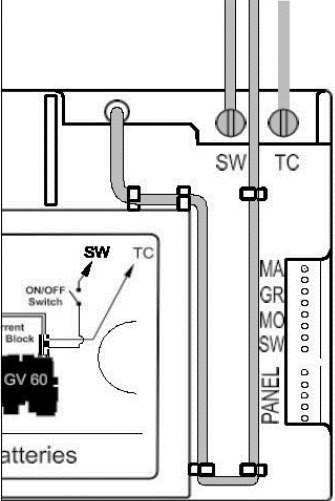

mode	Contact
Ignition	1 and 3
UP FLAME	1
DOWN FLAME	3
OFF	1, 2 and 3

3=black
 2=brown
 1=red
 0=orange

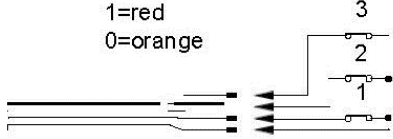

Cable w/connector G60-ZCE/1000

Figure 1: Wiring diagram and the operation sequence

Mode of Operation: The external source provides ON and OFF operation only. The Timer/Thermostat handset provides all other functions.

NOTICE: The Timer/Thermostat handset in Thermostatic Model controls the room temperature even if the fire is turned on by the external source. If the handset is in Manual Mode, the fire will go to High Fire in the next cycle of external operation.

NOTE: This wiring diagram is for hardwired smart home systems only and will not connect the fireplace to a wireless system.

Driftwood Log Set

Log placement of the Driftwood Log Set is crucial for optimal fireplace operation and safety purposes. Logs must be arranged as depicted in this manual. No other arrangement is permitted. No other interior design media options are permitted for the Wilderness 44H series fireplaces.

WARNING: Only media provided by Ortal is permitted for use in the fireplace.

WARNINGS: INSTALLING AND HANDLING MEDIA

- Log media is fragile, handle with care.
- **DO NOT** install the interior design media until fireplace installation is complete, the gas line is connected and tested for leaks, and initial burner operation has been inspected and approved.
- Media materials get very hot and will remain hot up to one hour after gas supply is turned off. Handle media only when materials are cool.
- If media is not installed according to the installation instructions, flame impingement and improper combustion may occur and result in soot and/or excessive production of carbon monoxide (CO). Carbon monoxide is a toxic, colorless, and odorless gas.

WARNING: The fireplace is not designed to burn real wood. Any attempt to do so could cause irreparable damage to the fireplace and may result in property damage, personal injury and/or loss of life.

NOTES:

- Log sets for NG and LP have different SKUs. Please consult the price list to ensure you have the correct SKU.
- LP logs do not contain nickel strands inside the logs. NG logs do contain nickel strands.

Log Placement

Logs must be arranged as detailed in the following pages. Alternative log arrangement will affect fireplace safety, operation, and performance. Handle logs gently to avoid paint damage. Log placement is the same for NG and LP.



Items supplied with Driftwood Log set

STEP 1

Use your fingers to separate the nickel strands (supplied 2x20" long) as shown in the pictures, about 1½" wide.



Left: Nickel strands as supplied | Right: Nickel strands ready to use

STEP 2

Place nickel strands on top of the burner holes.



Arrange logs as shown in the following pictures.

STEP 3

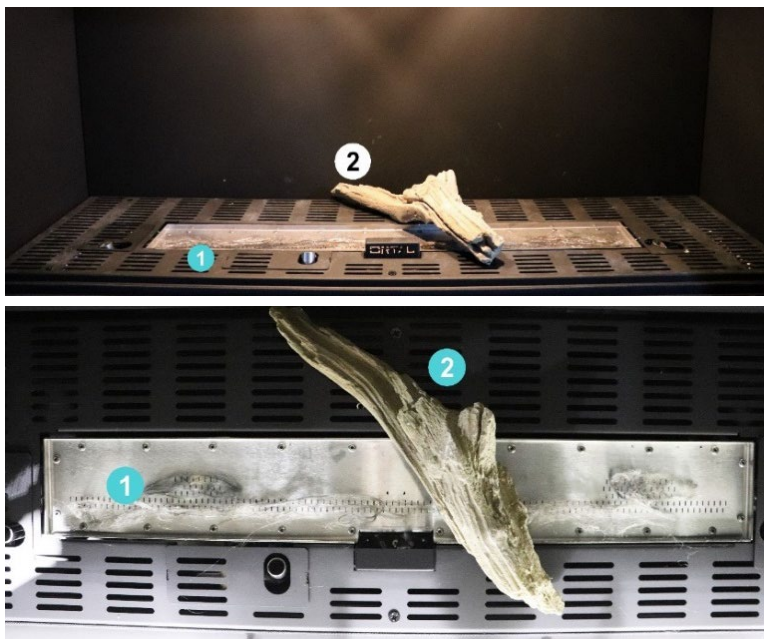

Step 3 Top View

STEP 4

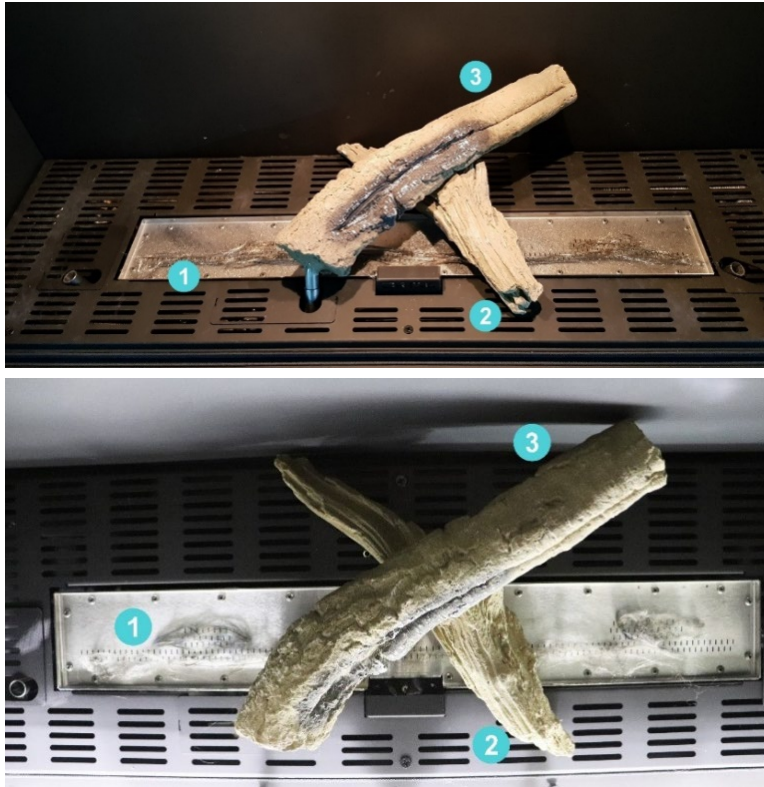

Step 4 Top View

The base of log #3 can be adjusted to fit the position shown in pictures above (see “Log Base Position Adjustment” section for details).

STEP 5

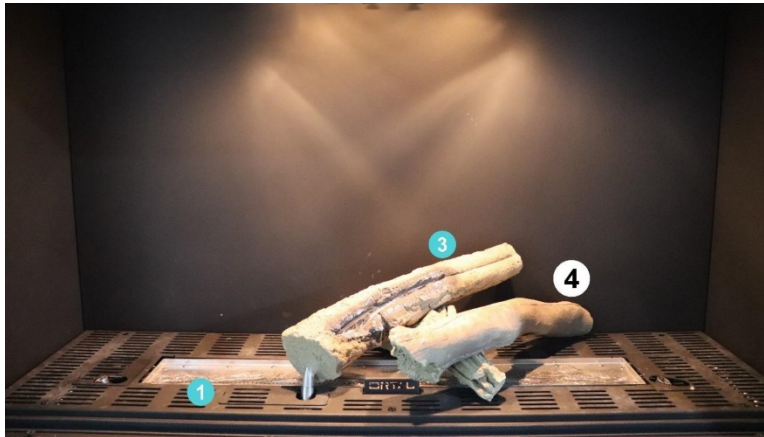

STEP 6

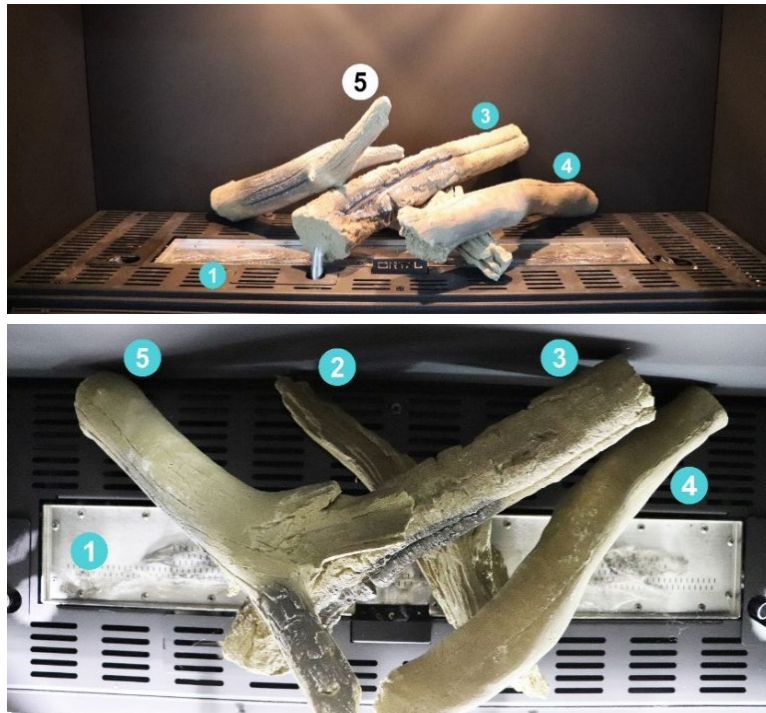

Step 6 Top View

STEP 7



Step 7 Top View

The base of log # 7 can be adjusted to fit the position shown in the pictures above (see “Log Base Position Adjustment” section for details).

STEP 8

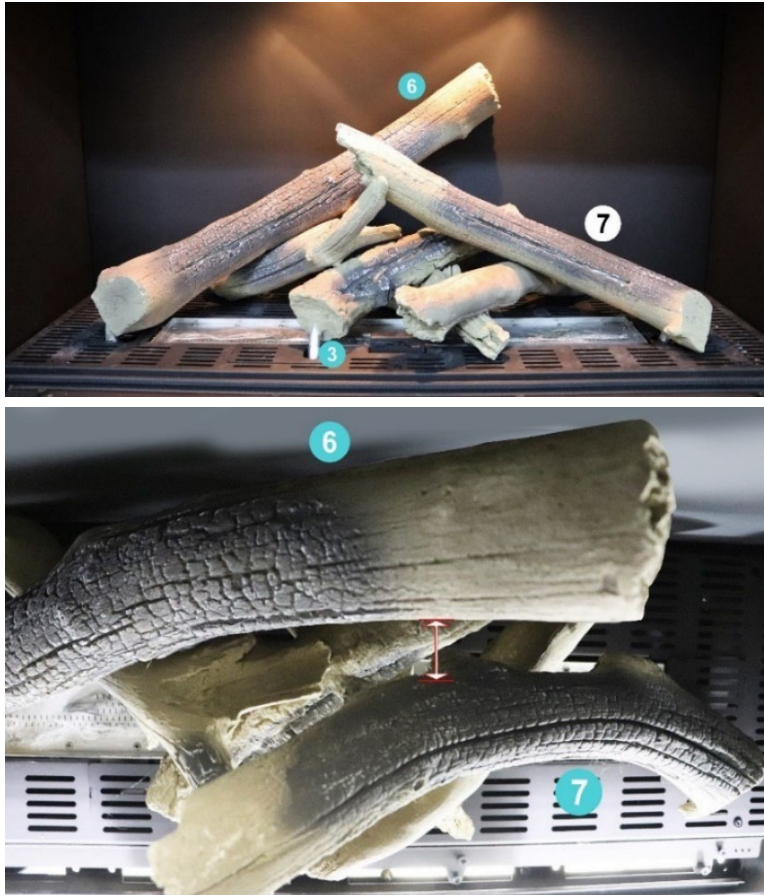

Step 8 Top View

The base of log # 6 can be adjusted to fit the position shown in the pictures above (see “Log Base Position Adjustment” section for details).

STEP 9

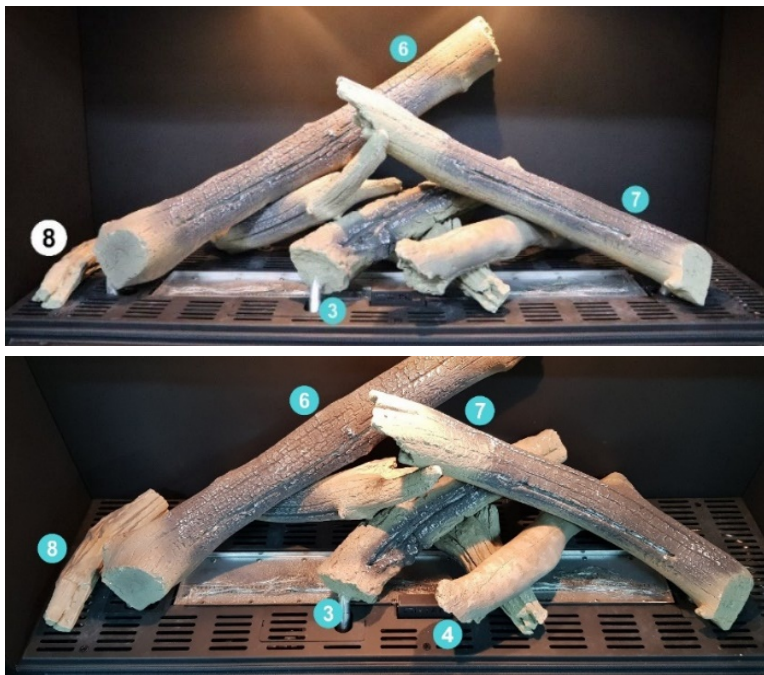

Step 9 Top View

STEP 10

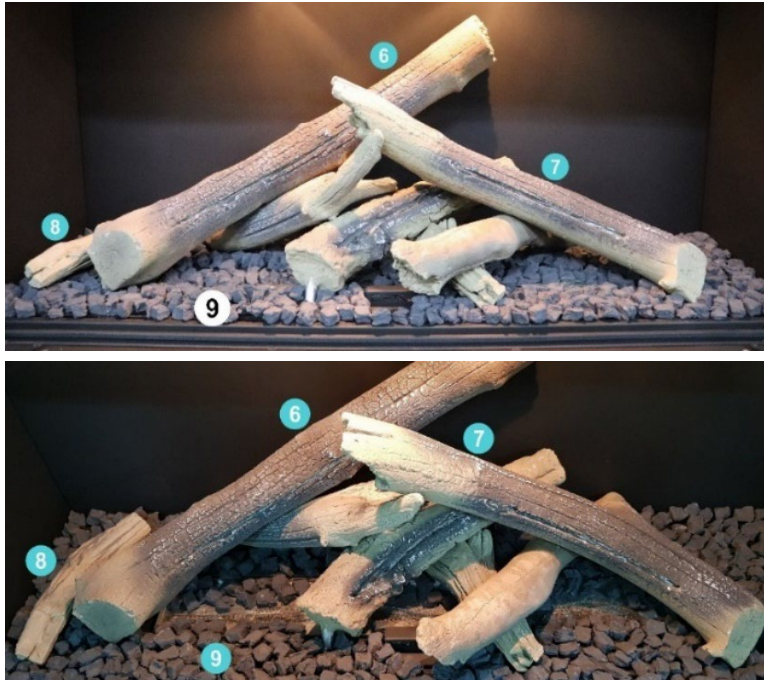

Step 10 Top View

STEP 11 (Optional)

Add pebbles.

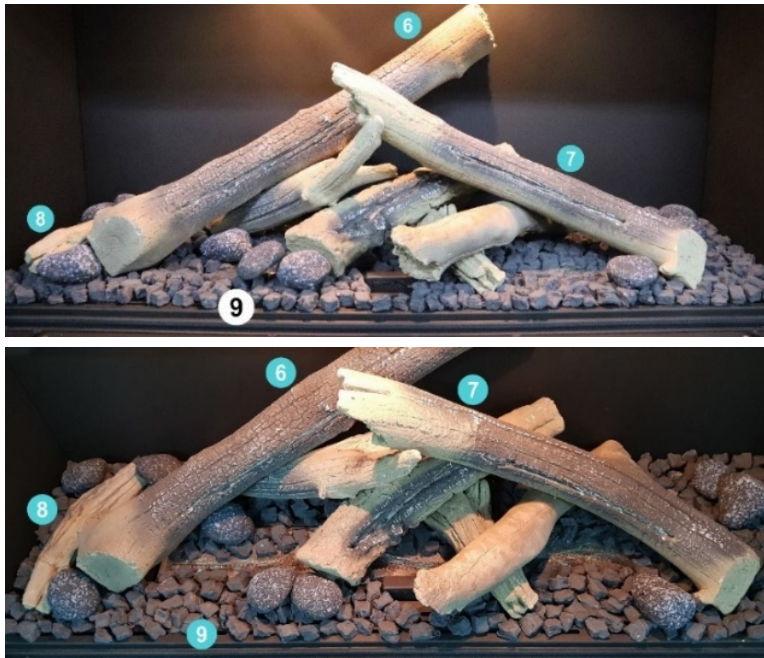

Step 11 Top View

Log Base Position Adjustment

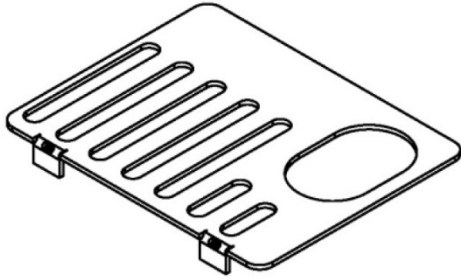

Left grill cover
(BL110DW002)

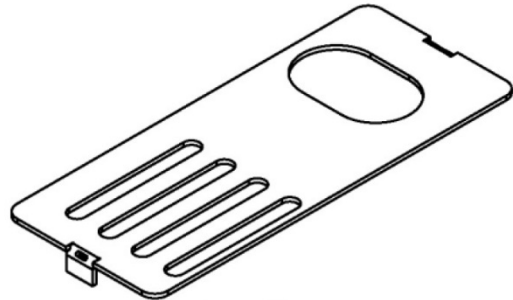

Center grill cover
(BL110DW003)

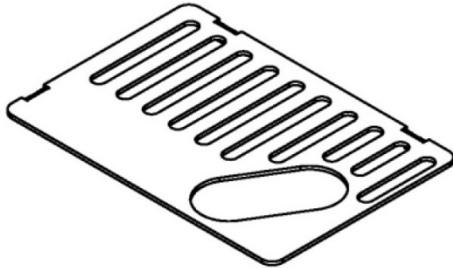

Right grill cover
(BL110DW004)

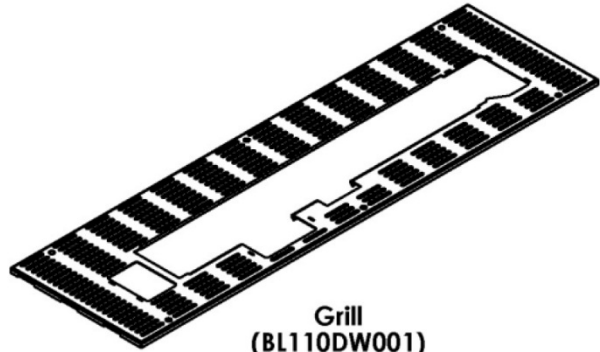

Grill
(BL110DW001)

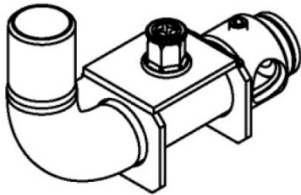

Left/Right
log base
(ASBL002)x2

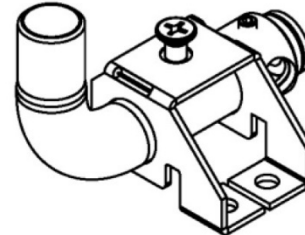

Center
log base
(ASBL004)

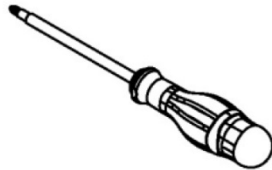

Phillips head screwdriver



2.5 Allen key

Tools needed

Adjustment Instructions

! NOTE: The following images are for illustrative purposes only.

1- Remove the front heat barrier in case the unit is DG, or net protected, and the front glass.

For more details, See the heat barrier and glass removal guide in Ortal manual.

2- Pull the logs vertically and take them out, as shown in figure (1).

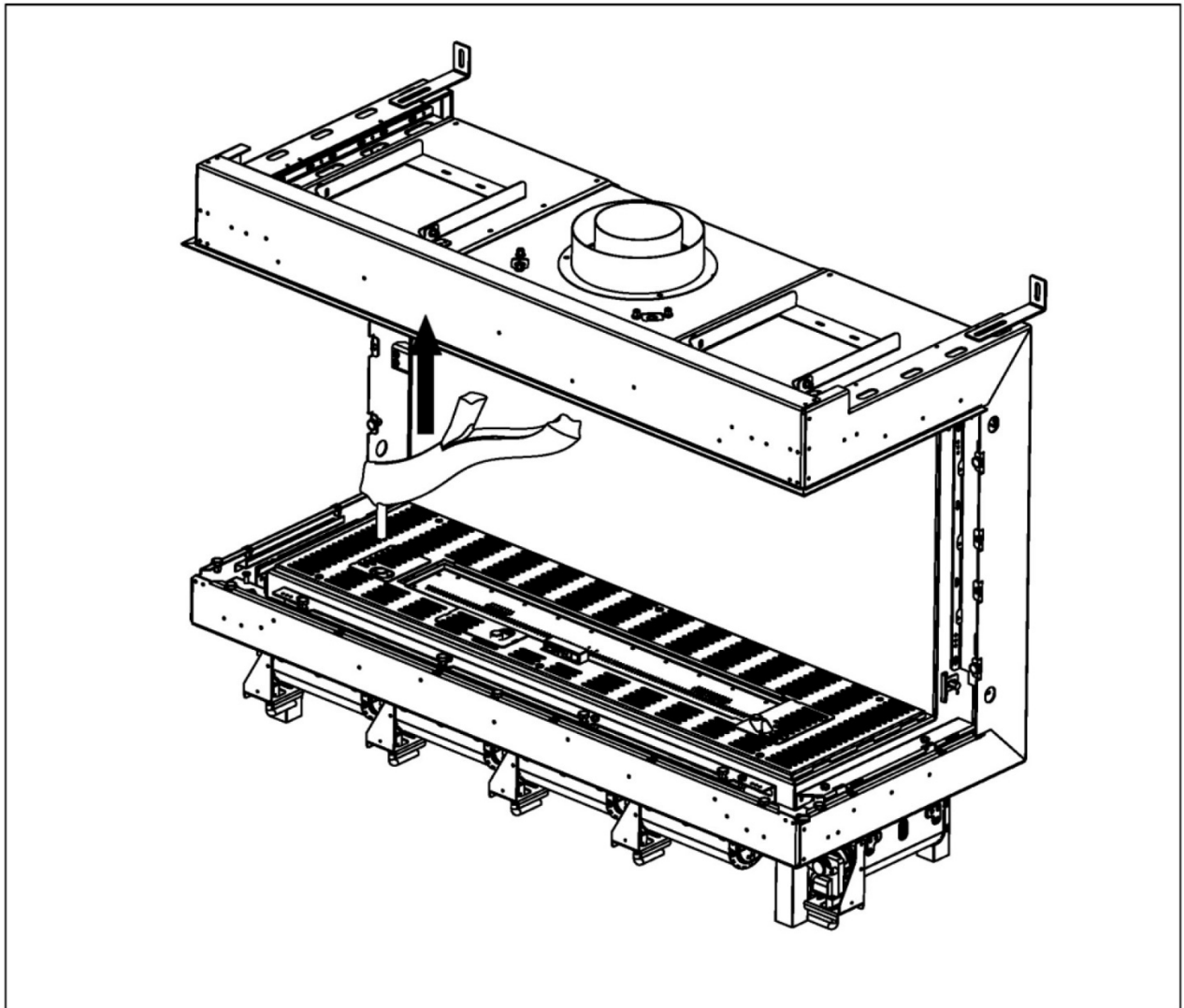

Figure (1)

3- Remove the grill covers as shown in figure (2).

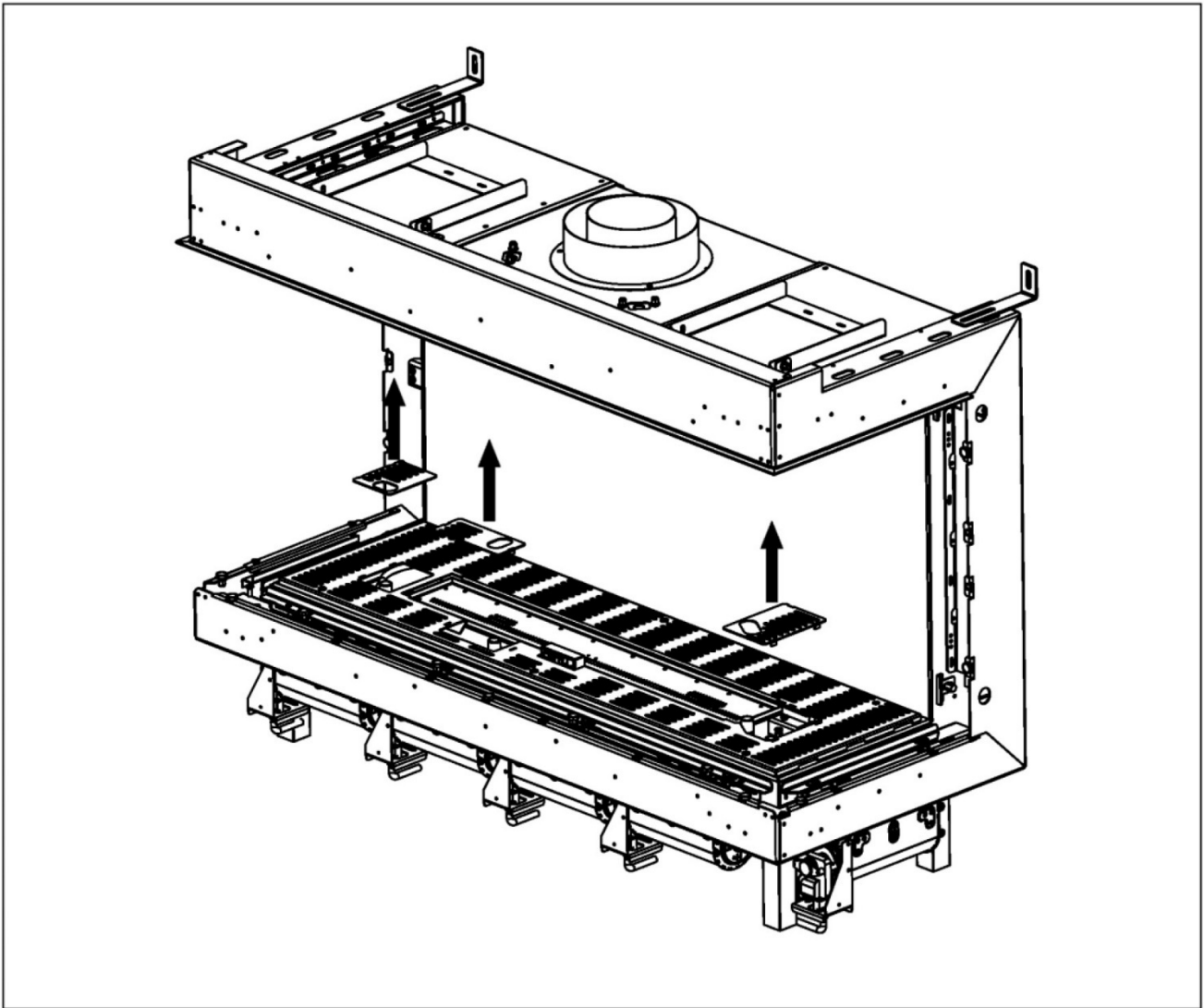

Figure (2)

Notice: Reassemble the system by performing the steps in reverse.

Adjusting log position:

- 4- Using a screwdriver loosen the log tube screw to change its orientation as shown in figure (3).

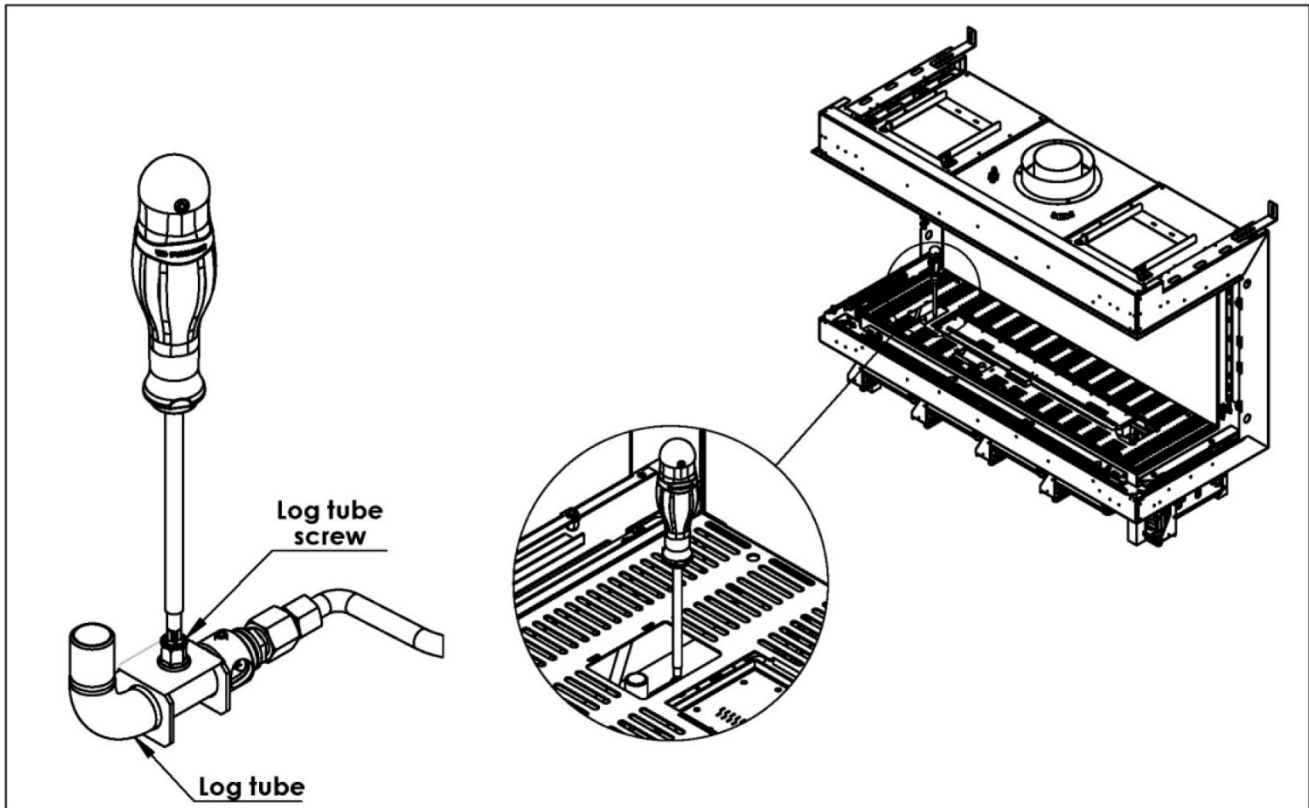

Figure (3)

- 5- Adjust the orientation as needed, as shown in figure (4), then tighten the screw again.

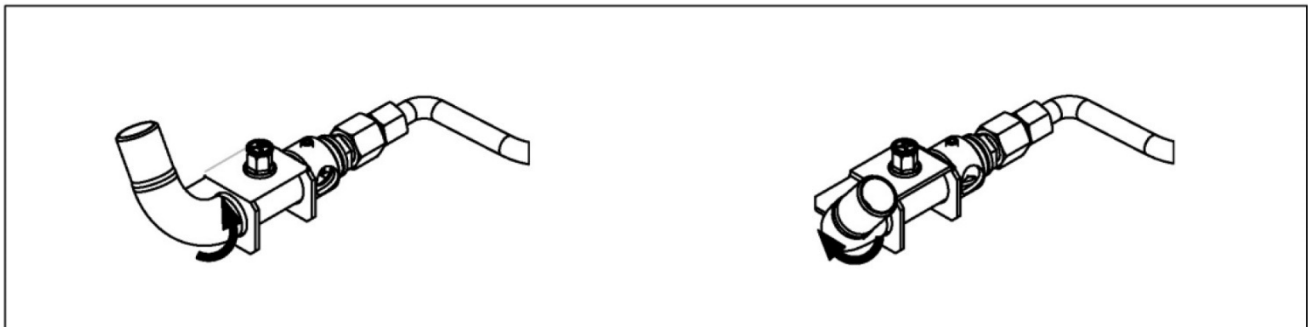

Figure (4)

Adjusting log base aeration :

- 1- Using (2.5mm allen key) loosen the aeration screw to change its position as shown in figure (1).

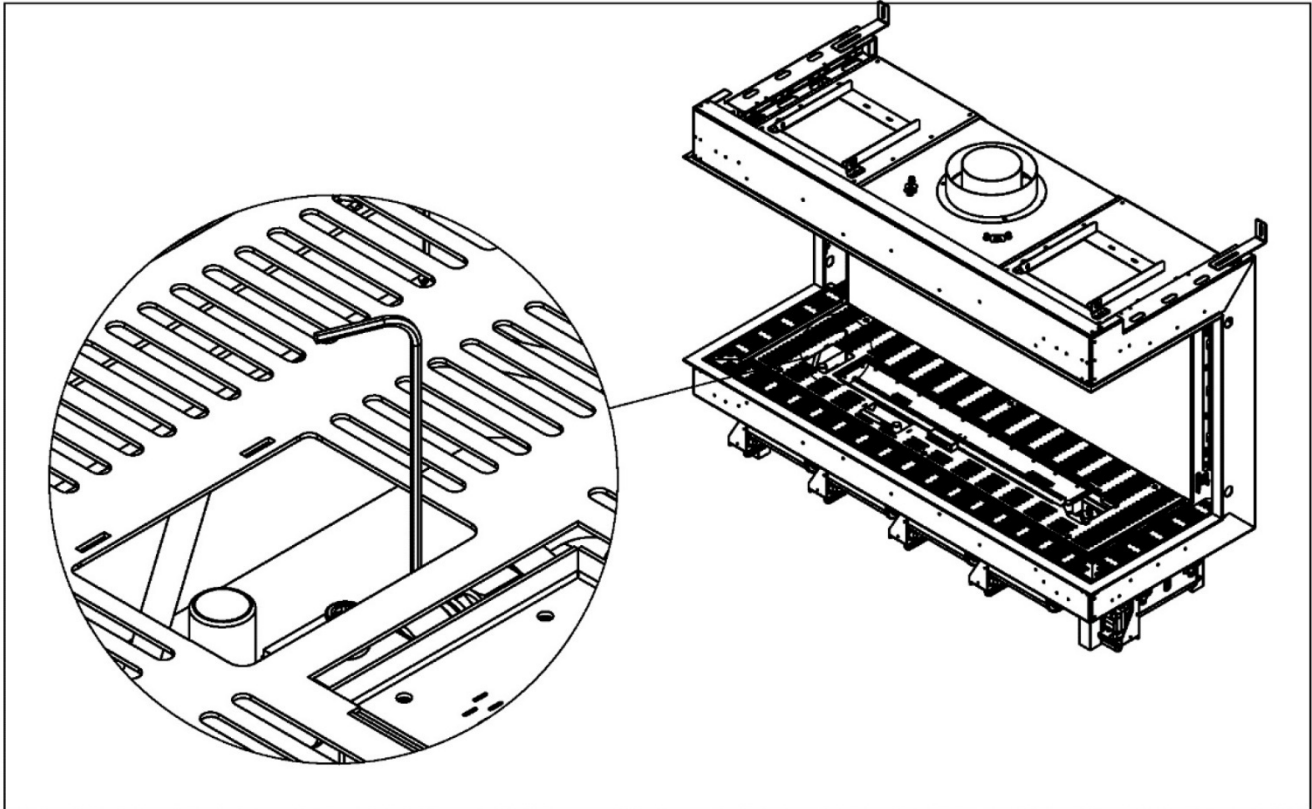

Figure (1)

- 2- Rotate the venturi to adjust the aeration as shown in figure (2), then tighten the screw again.

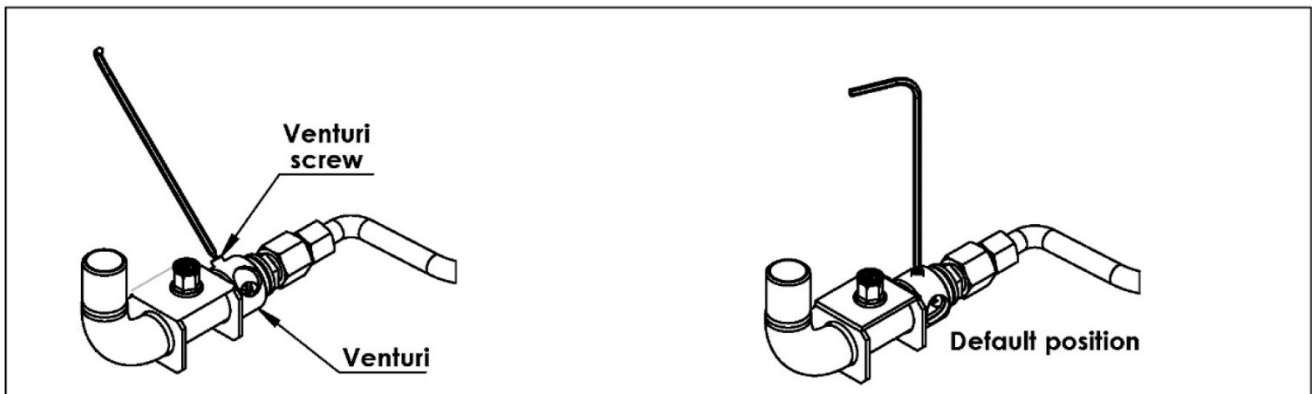

Figure (2)

Operation

WARNING – Read these instructions carefully before lighting the fireplace.

IMPORTANT NOTES:

- Wiring of valve and receiver must be completed before starting ignition. Failure to do so could damage the electronics.
- If operating the fireplace without an AC adapter, battery replacement is recommended at the beginning of each heating season.
- Fireplaces with double glass, power vent, and/or interior lighting features must operate using the AC Adapter and therefore will not operate during a power failure.
- Only the Mertik Maxitrol AC Adapter (or one pre-approved by Mertik Maxitrol) is permitted for use with the fireplace. Use of other adapter brands can render the system inoperable. The handsets, receivers, wall switches are not interchangeable with other electronics.
- Batteries must be kept within their recommended temperature limits (32°F to 131°F).

10-Button Remote Control Handset

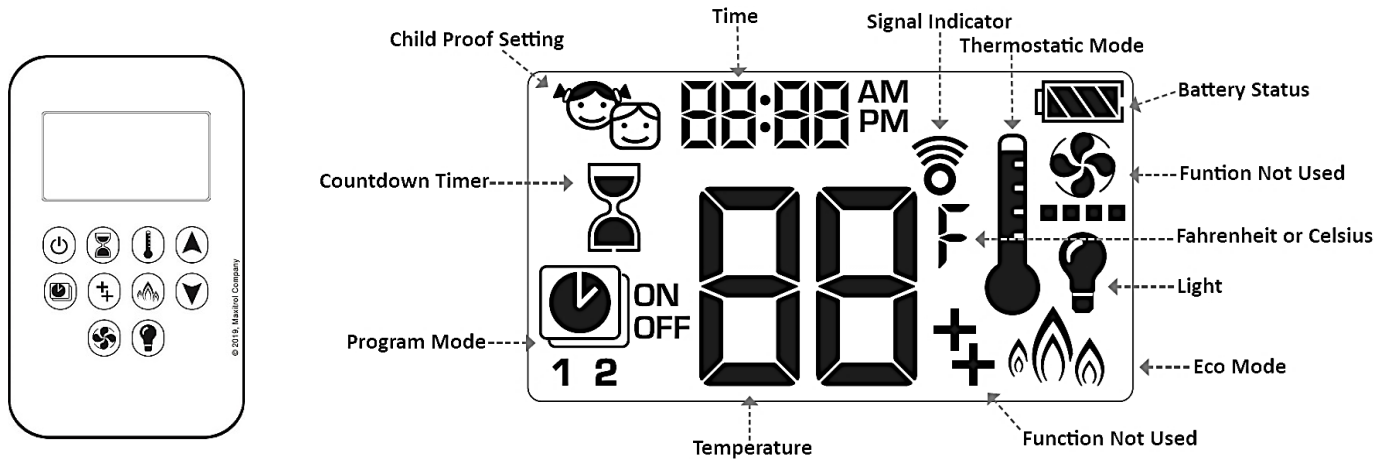

Control Option	Radio Frequency	Power Supply	
10-Button Handset	918.0 MHz (U.S. & Canada)	2 x 1.5V AAA batteries (quality alkaline recommended)	Replace batteries after 2 years or when low battery indicator appears on handset display
IMPORTANT: For safety/communication purposes, 10-button handset must be located within 26 feet of the receiver.			

NOTE: Any device that functions using the same radio frequency as the handset will be affected when handset is in use.

Operating Instructions

Instructions for operating the 10-Button Handset are shown below. For more in-depth instructions, please refer to the “Homeowner’s Fireplace Operation Manual” or “Remote Operation Instructions”.

NOTE: Some options on the remote may not be available for all fireplaces.

Turning the Fireplace On

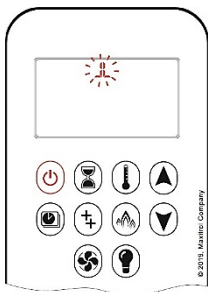



- Press the button until you hear continuous beeping, and a blinking series of lines confirms the start sequence has begun; release buttons.
- Main gas flows once pilot ignition is confirmed.
- The system automatically goes into Manual Mode after main burner ignition.

NOTE: When pilot ignition is confirmed, motor turns automatically to maximum flame height.

NOTE: If the Timer function has been set and the fireplace is manually turned on, the Timer function will need to be reset.

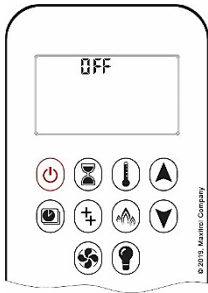
Turning the Fireplace Off





1. Press the  button to turn the fireplace off.

NOTE: The fireplace may be turned on again after the OFF icon stops flashing.

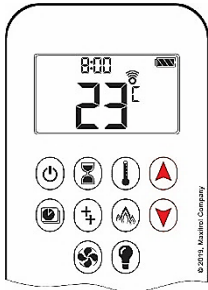
Flame Height Adjustment



1. To increase flame height, press and hold the  button to desired flame height.

2. To decrease flame height, or to set fireplace to pilot flame only, press and hold the  button.

Wall Switch

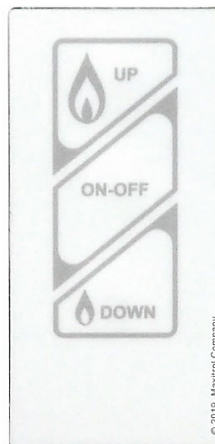

Control Option	Radio Frequency	Power Supply
Wall Switch	N/A	N/A

IMPORTANT: For safety/communication purposes, the 10-button handset must be located within 26 feet of the receiver.

Operating Instructions

Turning the Fireplace On/Off

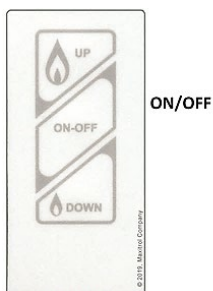

ON/OFF

ON: Press and hold the **ON-OFF** button until two short beeps confirms the start sequence has begun; release button.

OFF: Press the **ON-OFF** button.

Flame Height Adjustment

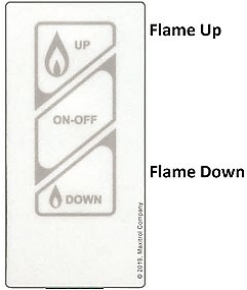

INCREASE: To increase flame height, press and hold (up flame) button.

DECREASE: To decrease flame height, press and hold (down flame) button.

Holding the (down flame) button long enough sets the fireplace to pilot flame (Standby Mode).

myFire App



MyFire.
Mertik Maxitrol GmbH & Co. KG

IMPORTANT: For safety/communication purposes, the 10-button handset must be located within 26 feet of the receiver.

NOTES:

- For detailed App setup and operating instructions, refer to www.myfireapp.com.
- The myFire Wi-Fi box is required for myFire operation.

myFire Wi-Fi Box

The myFire Wi-Fi router box provides the Wi-Fi connection that allows the myFire App to operate the fireplace.

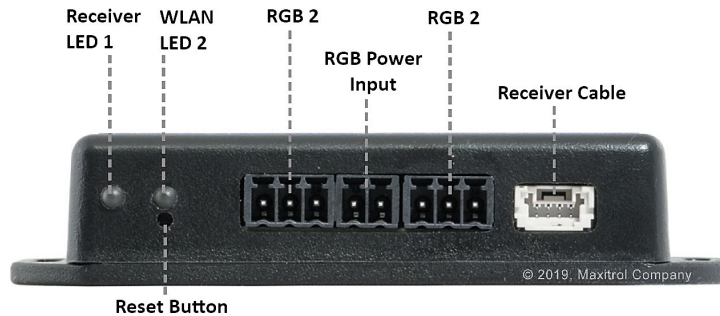

Part	Radio Frequency	Power Supply	Wireless Communication
myFire Wi-Fi Box	2.4 GHz	Connects to Receiver	WPA2 authentication AES 256-bit encryption security Compatible with IEEE 802.11 b/g/n

Fireplace Maintenance

General Maintenance

All servicing, maintenance, interior cleaning and handling of the fireplace, parts and glass must be performed by an authorized Ortal dealer service technician only.

Servicing

- Turn off the gas and electricity **BEFORE** servicing the fireplace.
- It is recommended that a routine inspection is performed at the beginning of each heating season.

- When removing glass from multisided fireplaces, only one side of glass can be removed at a time. Glass must be re-installed before removing glass from a different side.

Burner and Vent Inspections

- Periodic checks should be made of the burner for correct position and condition. Visually check the flame of the burner, making sure that the flames are steady.
- The vent system must be inspected before use. Annual inspection must be scheduled to ensure the flow of combustion and ventilation air.

Submerged Parts

- Do not use the fireplace if any part has been under water, or if you suspect that it may have been under water. The Ortal dealer service technician must inspect and, if necessary, replace any parts of the control system and any gas controls which have been under water.

Handling the Glass

Inner glass panel is 5mm ceramic glass. Exterior double glass panel is 3/16" tempered glass. Tempered glass can be sourced locally if replacement becomes necessary. Ceramic glass must be provided by Ortal.

- When removing glass from multisided fireplaces, only one side of glass can be removed at a time. Glass must be re-installed before removing glass from a different side.
- **NEVER** operate the fireplace without the glass properly secured in place.
- The glass must be removed **ONLY** by an authorized Ortal dealer service technician.
- The Ortal dealer service technician should **ONLY** remove the glass with the suction cup supplied by the manufacturer. Lower the glass to rest in a safe place to prevent damage to the glass edges.

Cleaning the Fireplace

- Only an Ortal dealer service technician can open the fireplace to clean interior surfaces.
- **ALWAYS** turn off the gas valve before cleaning.
- Do **NOT** clean when hot. Make sure fireplace has had time to cool prior to cleaning any surface or component, interior or exterior.
- Keep the fireplace clean by brushing and/or vacuuming at least once a year. This can only be performed by an Ortal dealer service technician.
- When removing glass from multisided fireplaces, only one side of glass can be removed at a time. Glass must be re-installed before removing glass from a different side.
- Clean the glass when it starts to look cloudy. Use a damp cloth for cleaning the fireplace and the door.
- Verify correct operation after servicing.

Maintenance Frequency and Equipment Checklist

- Under normal circumstances, the factory recommendation is to have the fireplace serviced at least once a year. Fireplaces meeting the following conditions should have more frequent service:
 - Fireplaces installed in commercial/public spaces should be serviced every 3 months.
 - Fireplaces installed in climates near the ocean or in other settings where corrosion buildup is more likely should be serviced every 6 months.
- Thermocouple Maintenance:
 - The thermocouple should be replaced annually or as needed in all commercial installations, and in any residential fireplace where the fireplace is operated for an average of 10 hours or more per day.
 - For all other installations, the thermocouple should be replaced every three years or as needed.

Troubleshooting

 Problem: The flame does not look yellow and consistent after 30 minutes of burn time.

 Solution:

1. Make sure the media setup is correct as required in this manual.
2. If still a blue flame is received after half an hour of operating, the air inlet should be reduced (see "Log Base Aeration" section).
3. If the flame is transparent and not continuous ("ghost flame"), the air inlet should be increased (see "Log Base Aeration" section).

 Problem: Fire is coming from the aeration opening.

 Solution:

1. Remove the relevant log and make sure nothing blocks the gas pipe inside the log and air can flow freely from the log openings.
2. Make sure nothing blocks the log base gas pipe. (No foreign objects stuck inside the pipe)

© Ortal 2020
Version 1, October 2020
SKU: KPMANWILD44V1

Ortal USA
8421 Canoga Ave Canoga Park, CA 91304
T: (818) 238-7000 | F: (818) 678-0541
info@ortalheat.com | www.ortalheat.com