



Study Group Report High-Dynamic-Range (HDR) Imaging Ecosystem

This SMPTE Study Group report is of work of SMPTE Technical Committee (TC) 10E SG on HDR Ecosystem which is comprised of 170 top international experts. The report summarizes an extensive discussion on the implementation of HDR in professional media workflows and addresses key questions that will arise for industry members as they move forward in taking advantage of HDR technology. The report also offers recommendations for further HDR standardization efforts by SMPTE and other organizations.



Study Group On High Dynamic Range (HDR) Ecosystem

Table of Contents

1	Introduction	3
2	Consumer Delivery - Background	3
3	Scope	4
4	Glossary	4
5	What Is High Dynamic Range?	5
5.1	HDR Displays.....	5
5.2	Viewing Environment.....	6
5.3	Digital Motion Imaging Cameras and HDR.....	7
6	Video Ecosystem and HDR Signals	7
7	HDR Workflow Discussion	8
7.1	Issues related to Production.....	9
7.2	Issues Related to Real Time and Non-Real Time Workflows	10
7.3	Issues Related to Real-Time Workflow	11
7.4	Issues Related to Non Real-Time Workflow.....	12
8	The Role of Metadata	14
9	Video Ecosystem Interoperations and Output Signal Conversions.....	15
9.1	Color Encoding Identification	15
9.2	Issues in conversions between HDR color volumes including Recommendation ITU-R BT.2020 to Recommendation ITU-R BT.709.	15
9.3	Content-Dependent Metadata	17
10	HDR Signals and Parameters	19
10.1	Display and Reference Viewing Environment	19
10.2	Test Patterns.....	19
11	Work on HDR Standards.....	19
11.1	Image Formats	19
11.2	Existing HDR Signal, Interface and Image Formats Standards	19
11.3	HDR Mastering Metadata Standards.....	20
11.4	HDR Production File Format	20

11.5	HDR Viewing Environment	20
11.6	SDI Payload Identification	21
11.7	SMPTE IMF Revisions	21
12	Need for New SMPTE Standards Documents	21
12.1	HDR/WCG Signals over SDI Interfaces	21
12.2	HDR/WCG Signals on 'Video over IP'	21
12.3	Metadata with HDR Signals.....	21
12.4	Metadata for Files.....	21
13	Recommendations of the SMPTE Study Group	21
14	Additional Industry Issues	22
Appendix A: Proponents' Proposals for supporting an HDR Ecosystem		23
A.1:	British Broadcasting Corporation (BBC):	24
A.2:	Dolby Labs-Dolby Vision™	25
A.3:	PHILIPS HDR - A parameter based HDR system	26
A.4:	Samsung's Proposal on Dynamic Metadata.....	27
A.5:	Technicolor: An HDR Home Video Mastering & Distribution Workflow	28
Appendix B: HDR Tone Mapping Technologies.....		29
B.1:	Academy Color Encoding System (ACES) for HDR and WCG Mastering:	29
B.2:	Disney Research - Temporally Coherent Local Tone Mapping of HDR Video	31
Appendix C: Possible HDR Interactions with the Human Visual System.....		32
Appendix D: Technical Options-reference material.....		35
D.1:	PHILIPS HDR – u'v' chromaticity option	35
Appendix E: Case Studies.....		37
E.1:	"Emma" an HDR Case Study	37
E.2	Blu-Ray™	41
E.3	BBC Hybrid Log-Gamma	45
Annex F: Works/ Standards Cited		49
Annex G: Bibliography.....		51

1 Introduction

The capture and display of content with a dynamic range that approaches real scenes has been a long term challenge. Limitations come from the choice of imaging technologies such as early pick-up devices (Vidicon, Image Orthicon) and the traditional video display device, the CRT. Until recently the industry has accepted that content capture and display technologies have inherent limitations that would limit the ability to reproduce more realistic High Dynamic Range (HDR) images.

Traditional capture techniques using film camera negative that has been used in motion picture and television episodic production has allowed more scene dynamic range to be captured by the film negative that was ultimately shown to the viewer in the film print.

The HDR Ecosystem needs imaging performance requirements that must be met with sufficient precision to ensure that high-quality color reproduction can be achieved on displays with different capabilities without introducing unacceptable artifacts. Properly designed HDR systems will dramatically improve the available creative palette and directly enhance the consumer experience.

There is a need for a better understanding of the set of elements, including standards, required to form a complete functional and interoperable ecosystem for the creation, delivery and playback of High Dynamic Range (HDR) image content. This report considers technologies to support both Real Time (linear) and Non-Real Time (non-linear) delivery and display. Real Time includes systems such as traditional broadcasting and Pay TV while Non-Real Time includes pre-made content and point-to-point distribution such as transactional and subscription delivery and display.

The parameters that make up HDR include higher peak luminance, lower minimum luminance, greater contrast range, and improved precision minimizing quantization errors that are beyond the capabilities of existing standards to deliver. Wide color gamuts are also going to be used. Implementers of HDR/WCG should also be aware of the impact that will arise with the use of higher frame rates.

While some standards activities are underway, it is important to understand the range of features, parameters, and impact of HDR images in order to identify gaps necessitating new standards and possible revisions or extensions to current standards. It is also critical to determine how these capabilities will integrate and co-exist with current conventional video and digital delivery ecosystems.

This study group report is not comprehensive in addressing all of the methods that are used to produce, process, and transmit video. The end-to-end capabilities of many production and distribution systems need to be considered in more detail than this report can provide. The focus is on areas where standardization is needed.

2 Consumer Delivery - Background

At the time of publication, the Advanced Television Systems Committee (ATSC) was considering how to deliver HDR content in the next-generation ATSC 3.0 terrestrial broadcast standard.

The Society of Cable and Telecommunications Engineers (SCTE) is also beginning to work on HDR transmission for future cable transmission.

The MPEG committee is also evaluating the impact of HDR and whether it requires the addition or modification of various tools in the HEVC compression standard

Internet streaming delivery of HDR content will also defined by both future industry standards and proprietary delivery systems.

ARIB in Japan has published a standard for OETF (ARIB STD-B67).

NHK has announced their time table for delivery to the home of HDRWCG images.

DVB in Europe is actively looking at the available options for home delivery

ITU-R SG-6 on Broadcasting has a Rapporteur Group (RG24) Recommendations on HDR television systems.

The Blu-ray disc Association has produced a set of HDR specifications

3 Scope

This report

- proposes definitions for HDR and related technologies;
- describes the gaps in the ecosystem(s) for the creation, delivery and display of HDR related content;
- identifies existing standards that may be impacted by an HDR ecosystem including Wide Color Gamut (WGC);

And

- Identifies areas where implementation issues may need further investigation.

This report also focuses on professional applications. While it takes into account consumer delivery issues, it does not explicitly discuss delivery to the home via satellite, cable, internet and off-air. Likewise, D-Cinema applications are not included.

4 Glossary

For the purposes of this document, the following terms and definitions apply.

Content-dependent metadata

metadata that can vary dynamically throughout the source content

Color Volume

solid in colorimetric space containing all possible colors a display can produce. (Color volume of an HDR display is specified by its color primaries, white point, and luminance range).

Electro-Optical Transfer Function (EOTF)

function that maps digital code value to displayed luminance (see also OETF)

High Dynamic Range System (HDR System)

System specified and designed for capturing, processing, and reproducing a scene, conveying the full range of perceptible shadow and highlight detail, with sufficient precision and acceptable artifacts, including sufficient separation of diffuse white and specular highlights

Luminance

luminous intensity of a surface in a given direction, divided by the projected area of the surface element as viewed from that direction. Unit is candela per square meter (cd/m^2). This is a simplified version of the SI definition. It is not to be confused with the term "luminance" in television and video to represent a quantity which may more precisely be referred to as "luma".

Non-Real-Time Workflow (NRT Workflow)

workflow capturing content to recording media for future processing and delivery (see also Real-Time Workflow)

NOTE: Content in this workflow may be subject to off-line editing, on-line editing, color grading, or other post-production processes prior to distribution to the consumer.

Opto-Electronic Transfer Function (OETF)

function that maps scene luminance to digital code value (see also EOTF)

Optical-to-Optical Transfer Function (OOTF)

function that maps scene luminance to displayed luminance

Peak Display Luminance

highest luminance that a display can produce

Real-Time Workflow (RT Workflow)

workflow capturing content and immediately processing it for delivery to the consumer, that is, not delivering content from pre-recorded media (see also Non-Real-Time Workflow)

NOTE 1: Pre-recorded elements can be integrated into the Real-Time Workflow, for example, advertisements

NOTE 2: Typically this content is also recorded for subsequent additional usage.

Scene-referred

attribute indicating that the image data represent the colorimetry of the elements of a scene

Standard Dynamic Range (SDR)

having a reference reproduction using a luminance range constrained by Recommendation ITU-R BT.2035 § 3.2 for video applications, or SMPTE RP 431 for cinema applications.

Tone Mapping

mapping luminance values in one color volume to luminance values in another color volume.

Transfer Function

single-variable, monotonic, mathematical function applied individually to one or more color channels of a color space

Wide Color Gamut (WCG)

chromaticity gamut significantly larger than the chromaticity gamut defined by Recommendation ITU-R BT.709

5 What Is High Dynamic Range?

High dynamic range is specified and designed for capturing, processing, and reproducing scene imagery, with increased shadow and highlight detail beyond current SDR video and cinema systems capabilities.

Human vision has a wide latitude for scene brightness, and has multiple adaptation mechanisms that provide an automatic 'gain' to the visual system. The brightness range that people can see is much greater than the available simultaneous contrast range of current displays. HDR systems are intended to present more perceptible details in shadows and highlights thus better matching human visual system capabilities under the several image viewing conditions typically found in consumer environments. In particular, HDR allows distinguishing bright details in highlights that are often compressed in traditional video systems, including allowing separation of color details in diffuse near-white colors and in strongly chromatic parts of the image.

5.1 HDR Displays

5.1.1 Reference Displays

Reference HDR displays should deliver increased brightness and darker shadows with a precision of luminance steps avoiding objectionable artifacts. It is insufficient to just raise backlight power causing increased black level, as greater dynamic range is essential. Simultaneous contrast as presented to the viewer is the most relevant measure of increased capabilities. The intended use of reference HDR displays is to provide consistency between production and broadcast facilities. Defining the characteristics of reference displays is essential.

HDR systems will improve over time and standards must allow for a potentially diverse range of output capabilities. Multiple display technologies with different capabilities are already present in the video ecosystem, and future technologies will inevitably bring improved performance.

5.1.2 Consumer Displays

For purposes of this study report, exact targets of peak luminance and achievable black level for consumer HDR displays have not been agreed upon and are largely considered an optimization issue for display makers who must evaluate issues such as panel capability, image quality, color gamut, cost, power consumption, manufacturing, etc. Further discussion and evaluation will be needed with other industry groups as well. It is expected that deployment of HDR will occur through gradual improvement and a migration over time to enhanced consumer equipment. Interoperation with traditional systems will be important.

The target parameters for HDR reference monitors for mastering applications needs to be standardized so that content can be reliably created in an interoperable manner.

5.2 Viewing Environment

The environment where a display is used greatly affects the quality of a reproduced image. A darkened room reduces reflections off the screen glass and allows a viewer to see the 'glow' of the lowest level 'on' value the display can produce. This was true of CRTs and is true of the currently popular LCD backlit panels.

In a week-long study of illuminance levels during television viewing, researchers sampled the changing light conditions every 5 minutes in 54 residential rooms in two parts of the country. They determined that for day time viewing, 82% occurred at levels between 0 and 100 lux although depending upon room position, weather, and window locations the ambient room light varied between 70 to 300 lux during the test period. 50% of the day time viewing occurred at levels below 30 lux. For night time viewing, 95% occurred at levels between 0 and 50 lux. The results suggest that with traditional television, having dim interior lighting conditions is a prerequisite for a large majority of both day time and night time viewing. The availability of higher brightness displays may lead to use of the bright range for viewing in brighter lighting conditions without necessarily providing extended headroom. Increased shadow range in displays will still be subject to limitations due to flare and to screen reflections of about 1% to 2% of the ambient on the front of the display. As in the above mentioned study, automatic brightness control may be an essential part of matching a display to room conditions, and a study of corrections for different room lighting environments might be a useful SMPTE effort.

A small addition of room lighting changes the perception of those same blacks so they look darker even though the display is putting out the same luminance.

In bright lighting such as a sunlit room or an office, the same image as before can appear dim, desaturated, low contrast, and have strong reflections on the cover glass from the environment.

As in traditional video and the human visual system, relative luminance within complex pictures and its relation to a viewer's state of adaptation is important to good reproduction.

In addition to the general lighting level in the room, the brightness of the area around the television affects the eye's response to an image and is known as the viewing surround.

The effect of these viewing surrounds have been widely studied in many imaging areas, with the 1967 study by Bartleson and Breneman being influential across multiple industries. The authors noted that to get an image to properly reproduce the impression of the brightness of the original scene, large changes were needed in the gradient (i.e. gamma/contrast) of the image. They noted for a dark surround, a gamma of 1.5 and for a dim surround 1.25. The essential idea is that the viewing surround effects the perception of the image and that an image being reproduced at levels much lower than its original brightness needs a substantial contrast boost to provide a pleasing reproduction. Only in the circumstance that the display brightness and the source content are in the same luminance range does a strict relative brightness reproduction of 1:1 work well. When flare and glare are also considered, tone scale characteristic curves are no longer linear.

Ambient and surround light have a large effect on perceived blacks and contrast and can change the choices in grading content to better reproduce images within a particular viewing environment. This becomes even more

pronounced when working with HDR content, especially in the darker regions of the display. For further issues, see Appendix C: Possible HDR Interactions with the Human Visual System. The appropriate level of surround lighting for mastering in HDR is currently not defined and needs testing against a range of HDR capable displays.

In an HDR system, and in several proposed transfer functions, the tone reproduction question is left to a colorist for pre-made material, and to the camera operator for live signals. There is no built-in gradient adjustment. Not having a system approach to the reproduction question leaves open the possibility of wider variance in quality and inconsistent presentation of material over time. Further investigation of tone reproduction for HDR is needed especially with the additional issues of interoperation with traditional video systems that have a 'system gamma'. (Sometimes called an OOTF).

5.3 Digital Motion Imaging Cameras and HDR

A number of technological movements are collectively, and significantly, influencing the design of contemporary digital acquisition systems. For the most part camera capture capability is not a limiting factor for high dynamic range.

Recently, the multipurpose nature of contemporary cameras and camcorders has been compounded by the rapidly growing interest in High Dynamic Range (HDR) and Wide Color Gamut (WCG). Already there are a number of manufacturers offering cameras that originate in 4K / UHD TV / 2K / HD accompanied by various levels of HDR and in some cases a choice among wide color spaces.

Log Encoding and RAW Recording

Almost all contemporary cameras having high dynamic range functionality use some form of log encoding to implement their respective camera OETF for file capture and transmission over SDI and other real-time signal interfaces. Each manufacturer has tailored their respective log curve to optimally capture with their sensor(s) both the detail in deeply shadowed and highlight regions of a given scene. The curves reflect the unique characteristics of the many different image sensors and they are not standardized. However, the mathematics to restore linear light representations are available to software vendors and postproduction facilities. Many also offer RAW recording options that are quite different to each other. RAW formats, and computer capabilities are sufficiently fast that RAW files can be played back in real time

6 Video Ecosystem and HDR Signals

HDR signals may be present anywhere in the video production ecosystem. As an example, Fig 1 is representative of a television production / broadcast facility. For the most part HDR/WCG interfaces are compatible with HDTV and UHD TV 10 bit and 12 bit signals and can be carried over existing 3-12 Gb/s interfaces. If, however High Frame Rate (HFR) signals such as 100 Hz and 120/1.001 Hz are to become part of an implementation new interfaces and infrastructure will be required. The existence of HDR signals and different display colorimetry can put new demands on systems interoperation as will be seen in § 7.

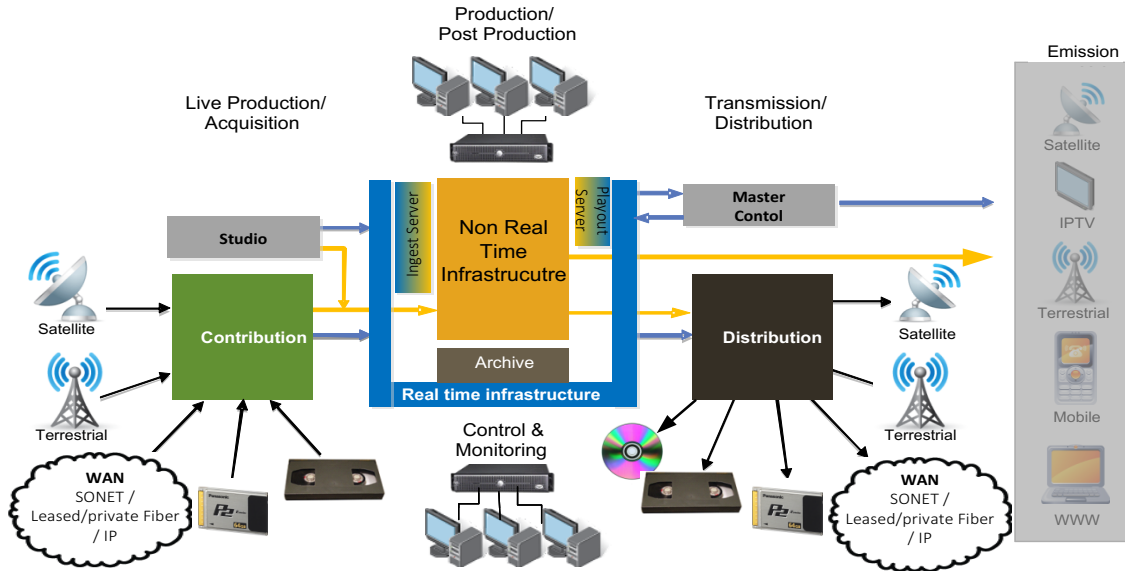

Figure 1: UHDTV Ecosystem Study Group Reference Diagram

Displays, image processors, up/down color converters will all need to detect the HDR encoding and colorimetry in use to correctly process and display the signal.

Compression and image processing is an increased part of many production and distribution systems, and the interaction of HDR signals with standard methods have not been fully explored.

7 HDR Workflow Discussion

HDR and WCG are emerging technologies which are still undergoing much development and there are various approaches proposed to create, transport, distribute and display HDR/WCG content. This is an implementation challenge for broadcast workflows which are complex in nature, highly automated and expensive to build. Broadcast networks rely on standards to ensure interoperability and to build cost effective workflows. Annex A represents a collection of manufacturers' approaches to WCG/HDR. The SG is aware of additional approaches, and would urge SMPTE to standardize interface and metadata solutions.

Implementing HDR/WCG with frame rates limited to a max of 50/60 Hz can be accommodated by existing multi link 1.5Gb/s, or multi link 3Gb/s interfaces, or 10Gb/s optical links. HDR/WCG signals will require that displays be changed to correctly display the images. The use of frame rates beyond 60 Hz that also include UHDTV pixel matrixes at 4K and 8K will require building a new infrastructure.

Figure 2 gives a high level simplified view of a broadcast ecosystem. It shows various processes in this ecosystem which might be affected by HDR and WCG content.

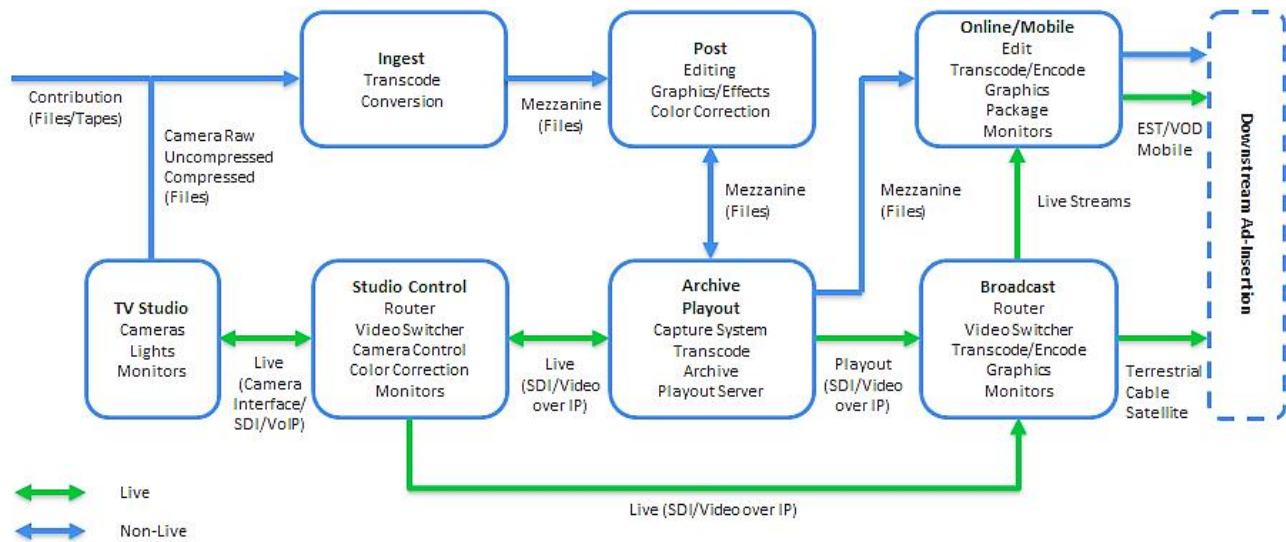

Figure 2: Simplified high level broadcast ecosystem

7.1 Issues related to Production

7.1.1 Production Image Monitoring

Displays capable of showing the entire captured image might not initially be available to production staff. The ability to switch between simulations of displays of different HDR capabilities will be important, it may be some time before productions integrate the use of HDR/WCG displays.

7.1.2 Signal Monitoring

Both HDR and SDR monitoring systems and processing equipment for on set and in-studio (e.g. studio monitors, multi-viewers, scopes, and waveform displays) are required to measure and view the full signal range that is recorded or transmitted.

7.1.3 Exposure Control

Exposure control during camera moves will become more important. [Stadium pans from daylight to shadow]

7.1.4 Studio Lighting

Taking advantage of the greater dynamic range in HDR will create more flexible and artistic requirements for lighting systems in the studio and on set. Just as in common practice today, cinematographers will both enhance the lighting range of some subjects and suppress the range of other subjects.

7.1.5 Camera and Image Metadata

The characteristics of the image dynamic range must be preserved, yet not all of the range coming from a camera can be seen with on-set monitors. Additional metadata created at capture may need to be defined describing viewing equipment and conditions, and methods must be created to deliver it to later users.

Camera, color correction and other metadata generated on the set that express the creative intent of the cinematography will be even more important to deliver for each scene using a system such as American Society of Cinematographers Color Decision List (ASC-CDL) through to dailies and editorial. Additional metadata created at capture may need to be defined, and methods created to deliver it. Production goals are to capture the full dynamic range of a camera and make it available to other departments.

7.2 Issues Related to Real Time and Non-Real Time Workflows

7.2.1 Target Displays

HDR/WCG Reference Monitor and environment specifications will need to be defined. Defining a reference display is dependent upon a complete specification of the WCG/HDR image format, including potentially higher frame rates.

7.2.2 Interfaces

Live video over IP (Layer 3) or Ethernet (Layer 2) technologies are emerging which make use of packet switched communication. They have already or will likely replace traditional serial interface technologies in some areas. All these interface technologies need to be considered when discussing HDR and WCG workflows.

Some standardization work has been done in SMPTE by creating the SMPTE ST 2022 family of standards for compressed and uncompressed video over IP. It will be necessary to revise this work to include the carriage and signaling of HDR and WCG content in addition to higher frame rates and the UHDTV image formats, and to ensure Lip Sync is maintained

7.2.3 Broadcast/Network Origination Centers (BOC/NOC)

It is expected that systems in a BOC or NOC control room that switch, record, measure, display, process overlay graphics or playback HDR/WCG content will need upgrading or replacement to support new features.

Multiple output signals for HDR and SDR may be created automatically from an HDR signal and these all need to be monitored.

7.2.4 Closed Captioning

Broadcasters are required to provide Closed Captioning (CC) to consumers with hearing impairments. HDR/WCG content might require an adjustment to the properties of CC and therefore the CC creation systems. Merging of CC with an HDR coding scheme will determine the magnitude of any changes to existing equipment

7.2.5 Broadcast Workflow Metadata

Existing interface metadata tables need to be adjusted to reflect the addition of HDR/WCG content types and messaging protocols need to be extended to cover these new content types.

Broadcast workflows for terrestrial, satellite, cable and IP distribution rely heavily on automated processing system workflows. To enable HDR/WCG processing as well as conversion between HDR/WCG and traditional SDR content in these workflows dynamic, scene or frame based metadata may be needed.

There is uncertainty on how such metadata can be bound to content and transported through automated workflows in a persistent manner. Processing and conversion systems like video mixers, encoding systems, and graphics systems might delete the metadata. Other processing systems (e.g. Digital Video Effects or even simple cross-fade switching) might alter the image content in a way that the associated metadata no longer reflects the image content. Metadata would need to be updated to reflect the new image parameters as well as a history on how the image was altered.

Complex sets of content-dependent metadata with Look Up Tables (LUT's), matrices, masks etc. which can be scene based or even frame based (in case of frame based switching of content) could require substantial, additional bandwidth in a transport channel.

Discussion relating to the optional use of frame or scene based metadata is currently underway

However, HDR production systems that do not require metadata may have advantages in broadcast workflows.

7.2.6 Content Conversion

It is expected that broadcasters and distributors will need to convert between SDR and HDR/WCG content to support delivery to all possible outlets and devices. This may be, for example, the conversion from (archival) SDR

to HDR/WCG content or the conversion from HDR/WCG content to layered content which allows backwards compatibility with SDR distribution and display systems. The following lists examples of possible conversion cases:

- Between different transfer functions
- Between different color volumes
- SDR to HDR and HDR to SDR
- Between HDR content with different HDR parameters

There is concern that concatenated content conversions will occur in complex large scale media workflows. These concatenated conversions may happen in a planned fashion or can be unknown by a content recipient who plans to convert content again. An unacceptable degradation of content quality could be the result; therefore, a historical trace of the conversion history is desirable.

7.2.7 Consumer Impact

The SG took note of consumer deliverables, however the details of final decisions in this area are outside the scope of SMPTE. Nevertheless, the capabilities of HDR content delivery / transmission systems and consumer displays may influence the HDR ecosystem and SMPTE standards that are needed in production and broadcast facilities.

HDR delivery on Blu-ray disc holds great promise for high quality. Work has already been put into defining new specifications for how this delivery will be done (See Annex E2), including the use of metadata and its transport over HDMI interfaces. (http://www.blu-raydisc.com/assets/Downloadablefile/BD-ROM_Part3_V3.0_WhitePaper_150724.pdf)

7.2.8 Audio Issues

This report deal mainly with Image related issues. Implementers should be aware of delays that may be introduced by signal processing or conversion that may change or impact audio lip sync. Where large number of audio channels may be present it is possible that the interface may not be able to carry all the channels, this could be the case when dealing with high frame rate signals being converted to lower frame rates.

7.3 Issues Related to Real-Time Workflow

7.3.1 Content and its Real Time Conversion

Consistent HDR attributes can be expected to simply system design and its operations. It is possible that HDR and WCG content will be delivered in a variety of HDR/WCG combinations of; colorimetry, peak luminance, maximum dynamic range, transfer function etc. It is further expected that some content will be conveyed in both HDR and SDR versions and with different color spaces (i.e. Recommendations ITU-R BT.709 and ITU-R BT.2020) Multi-format delivery should be avoided wherever possible.

These different HDR/WCG content types may need to be converted to conform to an in-house specification to allow seamless processing and distribution of content, and to conform to content delivery/transmission standards.

Transcoding systems and format converters will be needed to support HDR/WCG and higher frame rate content as well as mezzanine video compression formats. Current production systems have limited support for HDR and WCG but new tools will undoubtedly be introduced to remedy this deficiency. Of particular concern are older hardware based systems in graphics automation which can't be easily upgraded and will need to be replaced. Attention will need to be paid in all of the above processing equipment to ensure that audio 'lip sync' is maintained.

7.3.2 Remote Production Issues

There will be a need for live contribution links that support HDR and WCG. They currently use compressed signals with codecs which may not support HDR or WCG. Furthermore, the signaling of HDR/WCG content via these links is yet to be defined.

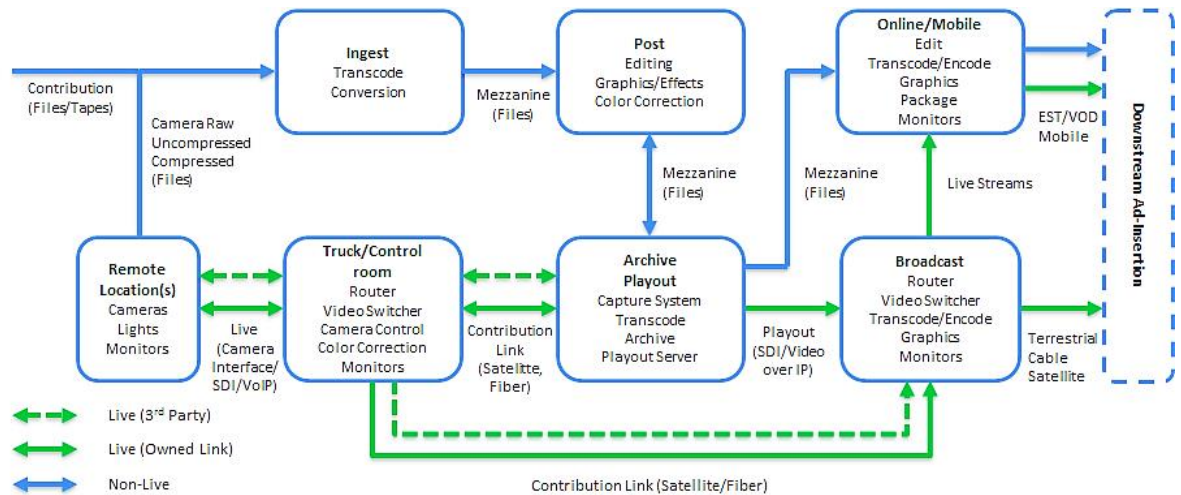

Figure 3: Remote Production ecosystem

Venue infrastructure that is not under control of a content distributor might utilize HDR and WCG technology that is not supported in the content distributor's infrastructure under its control. This could require a real-time conversion process. It might also require that remote location production equipment is constructed in a way that it supports multiple HDR/WCG technologies which may not be practical.

7.3.3 Ad Insertion

Of particular concern is content for advertisements (Ad's) that are either inserted at the content origination point (BOC or NOC) or dynamically overlaid by affiliates, cable and satellite operators, internet streaming delivery systems and other downstream content aggregators for localized Ad Insertion services.

These Ad's might not be controlled by the content distributor and might display different (or no) HDR/WCG properties than the broadcasted content stream. This will either lead to quality issues or will require deferred, automated content conversion.

7.3.4 Graphic Overlays

Graphic overlays and bottom of the screen "Scrolls" will have to be accommodated in such a way that HDR presentations when converted to SDR presentations produce acceptable results without complex conversions, or preferably no conversions.

7.4 Issues Related to Non Real-Time Workflow

7.4.1 Ingest, Storage, and Playout

Ingest systems may need upgrades or replacement to support HDR/WCG file formats, codecs and metadata. Storage or digital asset management systems may need updates to support storage, processing and distribution of metadata about HDR/WCG content, web service messages and user interfaces. Processing facilities such as transcoders and graphic overlay systems will require HDR/WCG support.

It is expected that at least 10-bit representation will generally be required for support of HDR/WCG content in codecs, signal paths, file formats and in applications, as well as metadata to flag the presence of such content. In the case of file formats, most file formats such as MXF are already 10 bit capable.

Interfaces for broadcast play-out will need to be upgraded to allow signaling for HDR/WCG content and, if applicable, the synchronized transport of content-dependent metadata.

7.4.2 Camera Grading and Editing

Non-live production in TV studios is usually based on recording the captured audiovisual content to files on data storage devices. This can be RAW image data or alternatively uncompressed or compressed image essence encapsulated in a file container format. There may be an additional step of HDR/WCG grading to be done in addition to the SDR grade. Additionally, post produced graphics and effects may need to be created for both formats. However, the complexity of separate parallel workflows will be problematic and there is a resulting need for automatic HDR to SDR conversion that meets performance and quality requirements

7.4.3 Camera Metadata

Camera, color correction and other metadata generated on the set will be even more important to deliver for each scene using a system such as ASC-CDL through to dailies and editorial. Additional metadata created at capture may need to be defined, and methods created to deliver it.

7.4.4 Dailies

Production on film used methods in which the full range of the image was unknown until a day after shooting. HDR may initially pose some new questions for the dailies process. Some of these questions are:

- 1) Does the editor need access to the full range of the image data, or is a SDR viewing copy sufficient? What is delivered from Dailies to Editorial?
- 2) Do viewing copies for the filmmakers need to be made to different display capabilities? (SDR video, computer screen, tablet, HDR reference monitors)?
- 3) Does grading on set become a requirement since camera exposure may vary widely to take advantage of different HDR regions?
- 4) How well can the DOP adjust the image capture if HDR monitors are not present?
- 5) How accurate a representation of SDR can be made from the HDR original without custom timing? (see ACES system. Appendix B.1)

The dailies editing system may need to support HDR. Depending on the requirements determined above, the display may or may not need to be a reference HDR display.

The metadata noted in the camera metadata section will need to flow through the dailies process and be delivered to editorial (e.g., Avid Log Exchange (ALE) data).

7.4.5 Editorial

As editorial generally works with the picture delivered from the dailies process, the likely scenario is that editors would work with the HDR dailies and create HDR and SDR viewing copies of the current edit as needed. The editing system would have to be capable of handling and processing HDR, and the display monitors could be similar to those used in the dailies process. A color management framework like ACES or HDR-SDR conversion equipment or plug-ins for the editorial system would be necessary to create SDR viewing copies. In the future, it may be possible to deliver a copy of an HDR edit with metadata, which would allow it to be played on any compliant monitor.

7.4.6 Mastering

In traditional feature mastering workflows, typically the cinema mastering is done first, and the home master is made from the cinema master. The home master often uses the cinema original aspect ratio image and color correction as a starting point, and performs a LUT conversion and resolution conversion to “video space”. Color and image trims are then performed to create the home masters in the desired resolutions and aspect ratios. Pan and scan and other processing is also performed to attain full-frame home masters at various resolutions and aspect ratios. Down-conversions are then performed on the HD masters to attain the required SD masters.

To create an effective HDR feature and television episodic MOW mastering workflow, the consumer deliverables as well as the mastering deliverables needed to create them must be defined, with a clear understanding of how

the consumer product will be reproduced and displayed on a consumer display. For the near-term, multiple masters may need to be created", some with metadata for certain distribution channels

7.4.7 Effects of Ambient Light in Mastering Suite

If one were to color correct a movie with a lot of detail in the blacks and you had a high level of ambient light you would naturally lift the blacks up to represent that shadow detail. If that is played back in a dark environment, then it will look lifted and washed out. The opposite case is when there is low level of ambient light in the grading suite and the blacks are adjusted for detail in that environment. When this is taken to a brighter ambient environment the content will look crushed.

As we extend our dynamic range then we must be more careful about the ambient conditions to support both the dynamic range and interoperability of content across systems. Specifying these ambient environments is key to interoperability. Monitors should have adjustments allowing for adjustments based on local lighting conditions a viewing environment target needs to be considered part of perceptual based image standards

7.4.8 Interoperable Master Format (IMF SMPTE ST 2067)

IMF is an option for a mezzanine master for HDR home-mastered content. The IMF specifications, which do not have HDR functionality as of this writing, are on a roadmap to expand the parameters to include HDR amongst related parameters, such as WCG.

IMF is also a solution for a business to business deliverable to distributors, who could then create specific deliverables for their consumers using Output Profile List. The IMF package delivered to distributors would likely be a specific subset of the master IMF, targeted at the deliverables required for the particular business partner.

7.4.9 Academy Color Encoding System (ACES)

A decade-long multidisciplinary effort by the Science and Technology Council of the Academy of Motion Picture Arts and Sciences has recently culminated in the release of the ACES 1.0 system. This system is predicated upon the concept of an ACES Color Space – having both an enormous color gamut and a much extended dynamic range. All of the different image sources are individually transformed as linear representations into that ACES color space that then enables powerful color grading options between them. ACES protects the integrity of all image sources and with native 33 stops of range can save all of the range of captured images. Each image source can be separately adjusted while protecting both their individual HDR and WCG. ACES provides an HDR production image container (SMPTE ST 2065-4) and a color managed image interchange framework that can be used for some mastering applications. Other details are provided in Appendix B.1.

8 The Role of Metadata

Throughout this report various references are made to metadata within possible workflow diagrams. Content-dependent metadata is intended to solve a problem of interoperation of HDR signals with SDR output displays or with HDR displays having less peak white capability than the source. These diagrams make assumptions which require verification as a result of testing and experience in the real world.

Common to both real time and non-real time workflows is the potential for a number of different metadata schemes from different manufacturers. Should multiple metadata schemes be standardized, application of different methods and preservation of all of the metadata stream may result in serious complications in deployment and operations across multiple media such as SDI, IPTV, file-based deliveries, etc. Further, if the technologies are licensable, vendor support across the video ecosystem will become fragmented.

Content-dependent metadata may or may not become an effective solution in the HDR ecosystem, but is in an active development phase. The presence of content-dependent metadata in the report does not represent a conclusion by all of members of the Study Group that it is required across all of the video ecosystem.

In general, it is highly recommended that while HDR metadata should be signaled in interfaces, the use of multiple HDR metadata sets should be discouraged. Such fragmentation will introduce complications to HDR workflows, and may lead to requirements for multiple HDR deliverables. This in turn could lead to a delay or even a barrier in adoption of HDR technologies by content creators and users.

Color volume conversion using standard and pre-set techniques is possible, and some believe it may be sufficient for SDR color reproduction from an HDR signal. However, it is thought by other proponents that color volume reduction in the conversion from HDR to SDR could benefit from the use of content-dependent metadata. Some regions of extended color and luminance only use a portion of the color space, and volume reduction of unaffected color regions unnecessarily reduces saturated or bright colors if applied without metadata. In a content-dependent metadata system, some automation of metadata creation for color transforms may be necessary, and automation of the output color conversions for multiple and diverse output streams will be essential. Different metadata-based color volume conversions may directly impact reproduction quality and consistency, and in the event of loss of the metadata stream, may lead to non-optimized dynamic range and color gamut reduction.

9 Video Ecosystem Interoperations and Output Signal Conversions

9.1 Color Encoding Identification

In common practice, the definition of the color encoded into a digital video signal requires knowledge of the transfer function, color space, the peak signal luminance value, the signal code range -- low and high codes, and bit depth. The color space can be defined with color primary chromaticities, white point, and coordinate system (RGB, YCC)

These values are set within standards such as SMPTE ST 2036-1 "Ultra High Definition Television - Image Parameter Values for Program Production" and SMPTE ST 2048 "Digital Cinematography Production Image Formats FS/709" which define unique relationships of signal code values to output display values by specification of the colorimetry and the digital image representation (i.e. encoding).

The addition of new signals such as Recommendation ITU-R BT.2020 and HDR encodings will require transmission of Payload IDs along with all signals to properly interpret the code values being transmitted. In Serial Digital Interface (SDI) applications, the Payload ID is defined in ST 352 and the SMPTE ST 2036 suite of documents use a bit-flag to identify either Recommendation ITU-R BT.709 or Recommendation ITU-R BT..2020 colorimetry. The payload ID will also have to be carried in IP interfaces utilizing various compression codecs. Other files and wrappers will also need to carry IDs for the code stream.

There may eventually be a large number of these IDs as different encoding combinations are used including other color spaces. Currently, video signals carry other encodings on an ad-hoc basis such as the transmission of camera 'log' signals. The potential future expansion of color spaces and additional HDR encodings requires a consistent signal ID scheme that can be carried across multiple digital formats.

The SDI payload ID scheme has a limited number of reserved bits available for expansion and the identification requirements for HDR systems should be examined.

9.2 Issues in conversions between HDR color volumes including Recommendation ITU-R BT.2020 to Recommendation ITU-R BT.709.

The SMPTE UHDTV Ecosystem Study Group Report (Mar 2014) discussed issues with standard dynamic range color space conversions in Annex C which describes wide color gamut Recommendation ITU-R BT.2020 conversion to traditional video color spaces.

In HDR, the problem is better thought of as conversion between color volumes having both 'width' and 'height' of the color space needing adjustments.

Content in larger color volumes present in HDR/WCG requires tone and chroma compression to 'fit' within a smaller volume. The effect of these changes can also affect the appearance of the image as a whole, and slight overall adjustments such as a small contrast boost or a change in saturation are often necessary to maintain the desired creative appearance of the original. Some compromises have to be accepted. For example, compression of bright colors into a SDR display can cause strong desaturation of bright colors which can go completely neutral. Depending upon the overall details in the scene, a colorist could choose to darken the relative values of the whole scene to retain some color in bright areas.

In initial applications, there are likely to be a matrix of typical conversions. For some of these conversions and accepting compromise in the color reproduction, sets of pre-defined transforms (including tone mapping and chroma management) may be defined. HDR luminance levels and Recommendation ITU-R BT.2020 are shown just as examples. Some color spaces 'fit' completely within the other's volume, but taking advantage of the higher capabilities of larger volumes often requires creative choices in mastering, so for HDR to HDR volume conversion it is just noted that a smaller volume fits within a larger volume. Some techniques may exist to convert SDR--> HDR, and these are just noted in the informative table 2 chart for future discussions. The use of multiple HDR signal formats may require too many conversions

Table 2: Signal conversions that could have preset transforms

From / To Input Format	HD ₁₀₀ Rec709	UHD ₁₀₀ Rec2020	HDR ₅₀₀ Rec709	HDR ₁₀₀₀ Rec709	HDR ₅₀₀ Rec2020	HDR ₁₀₀₀ Rec2020 Output format
HD ₁₀₀ Rec709	x	matrix only	SDR->HDR	SDR->HDR	SDR->HDR	SDR->HDR
UHD ₁₀₀ Rec2020	chroma compress	x	SDR->HDR	SDR->HDR	SDR->HDR	SDR->HDR
HDR ₅₀₀ Rec709	tone map	tone map & matrix	x	fits	matrix only	fits
HDR ₁₀₀₀ Rec709	tone map	tone map & matrix	tone map	x	tone map	matrix only
HDR ₅₀₀ Rec2020	tone map & chroma compress	tone map	chroma compress	matrix & chroma compress	x	fits
HDR ₁₀₀₀ Rec2020	tone map & chroma compress	tone map	tone map & chroma compress	matrix & chroma compress	tone map	x

Note- Subscripts indicate the peak luminance intended to be conveyed by the source or target format.

9.2.1 Static Conversion

An example of this is the subject of the standard SMPTE ST 2086 *that* provides the volume of colors that were used at the time of mastering as an outer constraint to displaying the content on an HDR/WCG display.

This metadata is useful when the signal encoding is a wide color gamut such as Recommendation ITU-R BT.2020, but only a portion of the color space was actually used in mastering.

An additional example of static metadata that may be included with HDR content are the MaxCLL and MaxFALL values that can be carried on the Ultra HD Blu-ray format. (See Annex E2)

9.3 Content-Dependent Metadata

When source content mastered with HDR/WCG is transformed for presentation on a display having a smaller color volume such as a SDR display, the color transformation process can be optimized through the use of content-dependent, dynamic color transform metadata rather than using only display color volume metadata.

As the content characteristics change from scene to scene, the optimal transform processing that best reproduces the content creators' artistic intent can change. For example, the color volume transformation parameters used for a very dark scene could be quite different from those used for a very bright scene.

As an alternative to archiving and managing multiple, transformed masters, one for each targeted video system, the transforms can be represented as metadata synchronized with the frames of one master. The metadata can be captured or generated as part of the mastering process, when images are creatively approved, and later applied in media conversions during the distribution stage.

It can be anticipated that real-time conversion of SDR->HDR and HDR->SDR will be used extensively in broadcast, cable and other live television distribution, in order to provide HDR content to new transmission standards and consumer displays and SDR content to legacy transmission standards and consumer displays.

It is uncertain whether future HDR content delivery/transmission systems, consumer display interfaces and displays will be capable of supporting content-dependent metadata. It must be further noted that downstream Ad Insertion and graphic overlays are additional factors that must be considered including complexity.

9.3.1 Per-scene Content Volume

Generic strategies for mapping of one color volume onto other is a complex task, and will require careful handling of the conversions to retain the original content intent. Gamut mapping has no perfect solution and different strategies may be employed. To aid in these algorithms, boundaries of the color volume can be provided on a per scene basis which can improve scene reproduction.

The range of color values used in a particular scene may be greater in some color channels than others. A general gamut mapping strategy treats the entire volume the same way and may, for example, desaturating all color channels to fit within another device's color volume. This affects the quality of the whole image for the sake of only a few color regions that may need adjustment. Knowledge that only certain colors are extreme in a particular scene allows optimization of the gamut mapping strategy to better preserve overall color

9.3.2 Grading Based Metadata

In some HDR encoding formats mapping from wider color spaces can be established during the mastering phase by creating a set of grading 'instructions' to be applied to the image to generate an image for a chosen smaller color volume display. The grading instructions can be captured by software as a colorist finishes the material, or can be calculated via various algorithmic approaches.

9.3.3 Content-dependent metadata Workflow

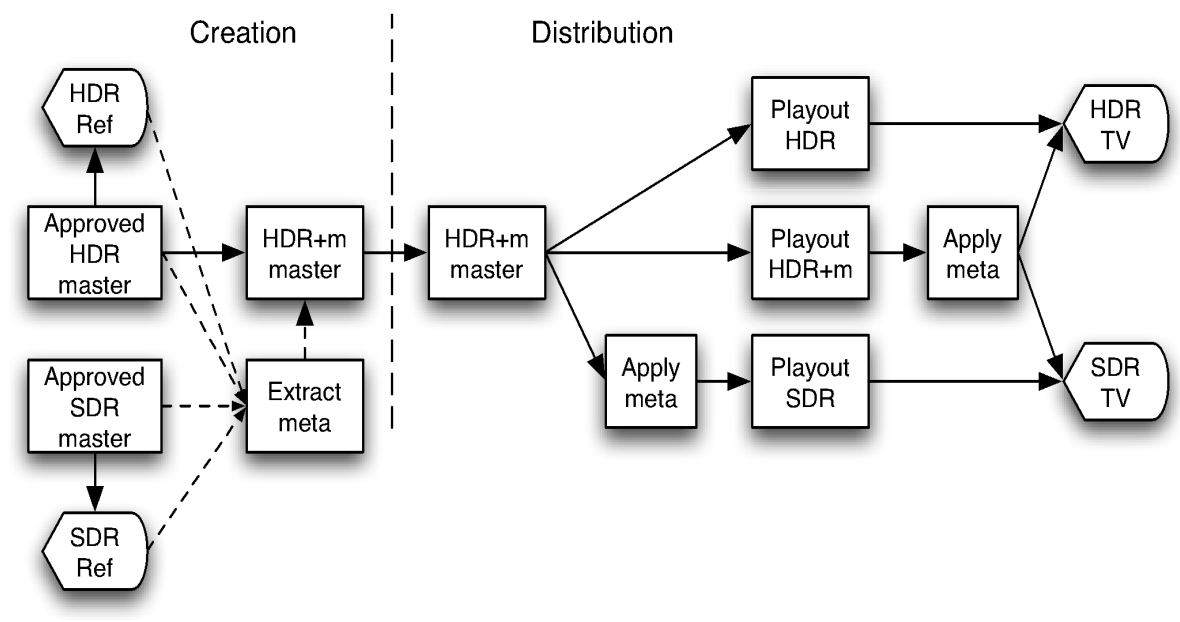

Figure 4: Example Workflow showing Combination of HDR masters with Content-dependent metadata

Figure 4 shows an example workflow using one method of content-dependent color transform metadata. Two approved masters are provided, here for HDR and SDR respectively. Content-dependent metadata is extracted from the mastering displays. Other metadata (such as the color volume and dynamic range) is obtained for each of the mastering displays. The metadata (or color transform parameters derived from it) is carried (here marked as "+m") with the master for distribution. On playout, the metadata is utilized to adjust the content to the color volume and dynamic range of the consumer display device. The metadata can be applied in the distribution plant, in the consumer source device, in the consumer display device, or not at all, depending on the needs and capabilities of the distribution channel and consumer equipment.

9.3.4 Target-Specific Transforms

The difficulty of content-dependent metadata systems is that multiple targets need to be defined for likely output displays, and interpolation between targets may be necessary for displays that do not have a setting that matches the requested target. (As an example, if content was graded and encoded for 2000 cd/m² and metadata was supplied for 800 cd/m², but the set only has a mode for 1200 cd/m² some decision has to be made about how to present the content as derived from the metadata.)

As multiple methods for color transforms may be provided each with their own metadata, the number of possible targets and transforms can quickly grow. A large and changing set of color transforms and metadata sets may challenge the optimal display of content since there may be device incompatibility or version issues that arise. Post-production masters will need to support all of the different metadata based methods.

10 HDR Signals and Parameters

10.1 Display and Reference Viewing Environment

Display technology is constantly developing. The SG feels that metrics for the following parameters as a minimum will need to be defined within a reference viewing environment to achieve interoperability. (see also § 11)

- Minimum simultaneous contrast ratio:
- Peak Luminance:
- Nominal Black level:

10.2 Test Patterns

Test patterns for HDR/WCG signals need to be defined also considering the varying setup abilities of HDR displays in terms of luminance and dynamic range.

11 Work on HDR Standards

11.1 Image Formats

The introduction of HDR and WCG technologies will offer the industry new choices for its production chain. HDR and WCG could be, in principle, applied to any existing image format. However, it is the recommendation of the Study Group that existing high definition image format standards should not be revised, rather, it is best if selected HD image formats and their parameters are included in a new video standard which contains a system of HDR Image formats, up to and including UHDTV pixel array sizes. These added HD formats are likely to mirror currently defined pixel arrays. These HD HDR image formats, when combined with WCG (and perhaps High Frame Rates), can define a new system that will provide a full system with improvements in image quality. The Study Group recommends that only progressive video formats be included.

The Study Group recognizes that emission formats may differ from the production formats due to bandwidth constraints. The issues surrounding choice of emission formats is outside of the Study Group's scope.

11.2 Existing HDR Signal, Interface and Image Formats Standards

- SMPTE ST 2084:2014 - High Dynamic Range Electro Optical Transfer Function of Mastering Reference Displays
- SMPTE ST 2048-1- 2048x1080 and 4096x2160 Digital Cinematography Production Image Formats FS/709
- ARIB STD-B67 : Essential Parameter Values for the Extended Image Dynamic Range Television System (EIDRTV). 2015

- Recommendation ITU-R BT.2077 Real-time serial digital interfaces for UHDTV signals

SMPTE, ARIB and ITU-R have published interface standards that provide sufficient bit depth and color sub-sampling as well as signaling of a wider color gamut, specifically, Recommendation ITU-R BT 2020, as described in SMPTE ST 2036-1.

Table 3: Example of interface standards supporting HDR application thru higher bit depth, WCG signaling

Standard-	Data Rate	Supported Pixel Array	Color Space Support	Max. Bit Depth	Color difference Sub-Sampling
SMPTE ST 425-3	Dual Link 3Gb/s	1920x1080	Rec.BT.709, Rec.BT.2020	12 bits	4:2:2/4:4:4
SMPTE ST 425-5	Quad Link 3Gb/s	3840x2160	Rec BT.709, Rec.BT.2020	12 bits	4:2:2/4:4:4
SMPTE ST 2081-10	6Gb/s	1920x1080	Rec.BT.709, Rec BT.2020	12 bits	4:2:2/4:4:4
SMPTE ST 2082-10	12 Gb/s	3840x2160	Rec BT.709, Rec BT.2020	12 bits	4:2:2/4:4:4
SMPTE ST-2036-4	10Gb/s Multi Link	3840 x 2160 7680 x 4320	Rec BT.709 Rec BT.2020	12 bits	4:2:2/4:4:4
SMPTE ST 2036-3	10Gb/s Multi Link	3840 x 2160 7680 x 2160	Rec BT.709 Rec BT.2020	12 bits	4:2:2/4:4:4
SMPTE ST 2048-1	10Gb/s Multi link	2048x1080 4096x2160	Rec BT.709 FS. Log	12 Bits	4:2:2/4:4:4
Rec ITU-R BT.2077	6Gb/s, 12 Gb/s, 24Gb/s Multi Link.	3840x2160 7680x4320	Rec BT.709 Rec BT.2020	12 Bits	4:2:2/4:4:4/4:4:4:4 ¹

11.3 HDR Mastering Metadata Standards

- SMPTE ST 2086:2014 - Mastering Display Color Volume Metadata Supporting High Luminance and Wide Color Gamut Images

11.4 HDR Production File Format

- SMPTE ST 2065-4:2013 - ACES Image Container File Layout

Extend metadata to include mastering and content-dependent metadata as necessary

11.5 HDR Viewing Environment

Viewing environment parameters and investigation of surround light levels for HDR sufficient to prevent adaptation and to provide proper shadow visibility. As part of the viewing environment there is the need to define a reference display. The decision to normatively define a reference display is dependent upon the HDR coding scheme and how the EOTF, OOTF, and OETF are defined.

¹ For part 1 only.

11.6 SDI Payload Identification

Method to allow different color space encodings, and provide for extensions in the future. The use of the SDI payload identifier may be one solution? (SMPTE ST 352)

Review and extend existing messaging protocols to support HDR and WCG content interfaces

11.7 SMPTE IMF Revisions

IMF-updates to current standards:

1. Higher level JPEG Profiles
2. Support for Recommendation ITU-R BT.2020 .
3. SMPTE ST.2084
4. Metadata carriage for SMPTE ST.2086 metadata.

12 Need for New SMPTE Standards Documents

12.1 HDR/WCG Signals over SDI Interfaces

Standardize methods of carriage of HDR/WCG imagery over SDI (including signaling and content-dependent metadata flow)

There is a need for a standard that defines image formats for HDR. (See section 11.1)

There is a need for SMPTE to investigate what changes to the current interface payload identification is required to signal HDR parameters.

12.2 HDR/WCG Signals on 'Video over IP'

Standardize methods of carriage of HDR/WCG imagery on Video over IP (including signaling and content-dependent metadata flow)

12.3 Metadata with HDR Signals

Standardize metadata for content-dependent color transforms of HDR content to displays with smaller color volumes.

If standardization cannot be achieved, then a need exists for perhaps an RDD for each metadata format and this means that the mastering process will need to generate multiple proprietary transform metadata formats, or the industry will need to eliminate some choices

12.4 Metadata for Files

File and code stream wrappers will also need to carry the same content-dependent metadata if needed for proper signal interpretation for alternate display capabilities.

13 Recommendations of the SMPTE Study Group

1. Investigate how content-dependent metadata can be transported persistently thru professional media workflow.

2. The SDI payload ID scheme (SMPTE ST 352) has a limited number of reserved bits available for expansion and the identification requirements for HDR systems should be examined
3. While HDR metadata should be signaled in interfaces, the use of multiple HDR metadata sets should be discouraged. Such fragmentation will introduce complications to HDR workflows, and may lead to requirements for multiple HDR deliverables. This in turn could lead to a delay or even a barrier in adoption of HDR technologies by content creators and users
4. Automatic brightness control may be useful for matching a display to room conditions, and a study of corrections for different room lighting environments might be a useful SMPTE effort.
5. The target parameters for HDR reference monitors for mastering applications need to be standardized soon so that content can be reliably created in an interoperable manner
6. Annex A represents a collection of different manufacturers' approaches to WCG/HDR. The SG is aware of additional approaches, and would urge SMPTE to standardize interface and metadata solutions.
7. Investigate effects of concatenated content conversion on HDR material including the relevant history of conversions.

14 Additional Industry Issues

As noted in many sections of this report, it is uncertain whether future HDR content delivery/transmission systems, consumer display interfaces and displays will be capable of supporting dynamic, content-dependent metadata. It must be further noted that downstream Ad Insertion and graphics overlays are additional factors that should be considered.

The complexity of content production and broadcast systems that might be needed to support multiple versions of content with different (or dynamic) HDR parameter sets should motivate harmonization and standardization of HDR parameters across content delivery/transmission, consumer display interfaces and displays. Through its liaisons with other Standards Development Organizations, SMPTE should strongly encourage and promote this desirable situation,

"Displays capable of showing the entire captured image might not initially be available to production staff. The ability to switch between simulations of displays of different HDR capabilities will be important

The issues below may not be in the realm of SMPTE standards, but will be needed to be defined and/or agreed to by the industry... Without some agreements the displayed HDR images may fall short of expectations

Define consumer display parameters and capabilities.

1. Define Distribution Compressed File Formats.
2. Define emission compression schemes and their characteristics.
3. Recommended home viewing environment.
4. HDR has the potential to change the hazard posed by Photo-Sensitive Epilepsy. A background paper is "Binnie, CD, Emmett, J et. al., "Characterizing the Flashing Television Images that Precipitate Seizures", SMPTE Mot. Imag J. July 1, 2002 Vol. 111 No. 6-7 pp323-329"

Appendix A: Proponents' Proposals for supporting an HDR Ecosystem

In response to a call for contributions to the Study Group the following “single page” contributions were received. The contributions have been reproduced as presented and do not reflect opinions of the Study group. It should also be noted that the contributions were valid at the time of submission. It is known that development and refinement of the proposals have taken place since they were contributed.

NOTE: The proposals presented in this Appendix A utilize terms and definitions of the proponents that may not adhere to the definitions and terms in the body of the consensus Study Group Report. In order to avoid confusion, it is important for the reader to not extend the use of the definitions and terms beyond the respective proposal.

A.1: British Broadcasting Corporation (BBC):

There is currently a great deal of technological change in the television industry instigated by an increase in the number of pixels in cameras and displays. However, one perspective is that simply increasing the number of pixels would not provide a sufficient increase in perceived quality to justify initiating a new broadcast service. We think that a combination of higher frame rates, wider color gamut and, particularly, high dynamic range (HDR) may provide sufficient improvement to justify a new service. If the BBC were to provide such a service it would have to be practical and cost effective. Furthermore, such a service must be based on open standards, preferably royalty free, to promote maximum access and free and fair competition within the industry. The BBC's HDR proposal aims to address these requirements.

We have been liaising with many members of the broadcast industry. Our current HDR proposal is based on information from discussions within the industry. The details of our proposal have evolved over the past few months as a result of feedback from the industry about earlier proposals. Most recently the BBC and NHK have combined their approaches, and a revised OETF has been standardized by ARIB (STD-B67). The current proposal is substantially similar to an earlier proposal but has been optimized for both dynamic range and for compatibility with existing SDR standards.

The BBC's proposal is to replace the conventional gamma curve, specified in ITU Recommendations 601, 709 and 2020, with an HDR alternative. Simply increasing the bit depth of the conventional gamma curve would not provide a sufficient increase in dynamic range. We propose to retain more or less the conventional gamma curve for low lights and use a logarithmic curve for highlights. In the low lights we propose to use a pure gamma curve for the electro-optic transfer function (i.e. the "gamma" curve in the camera), without the linear part used hitherto. The linear part of the curve was, previously, used to limit camera noise in dark parts of the picture. However, HDR cameras necessarily have lower noise and so the linear part of the curve is no longer appropriate; removing it increases the dynamic range. In the highlights, the bright parts of the picture, we propose to use a logarithmic curve, which increases the dynamic range in a psychovisually optimum way when Weber's law of vision applies. The logarithmic curve is chosen to be continuous with the conventional gamma curve, and the slope of the curve is also continuous, providing a smooth OETF overall. In some ways our proposal is similar to the use of "knee" characteristics ubiquitous in live TV cameras, with the advantage that the receiver can reconstruct the HDR signal rather than the highlights simply being "crushed".

On the display side we have proposed a parameterised electro-optical transfer function (EOTF) which allows the signal to be displayed on a wide range of displays, with varying peak luminance, black level and viewing environments, to produce a high quality picture. This feature is essential to support the conventional model of video production and distribution. In addition to allowing for variations in black level and peak white the BBC EOTF also supports variable end-to-end system gamma to support varying viewing environments.

We do not think that an 8 bit signal is adequate for HDR either in production or for distribution. But we believe 10 bits is sufficient for both production and distribution. Ten bits has the advantage of being compatible with existing production infrastructure. With ten bits our HDR proposal can support dynamic range about 100 fold greater than SDR television. 12 bits might also beneficially be used in production.

We believe HDR signals using our proposals are sufficiently similar to conventional signals that we could continue to use existing infrastructure such as 10 bit SDI interconnects, compressed links and existing SDR monitoring. Our proposal would not require end to end metadata during the production process. This is important as experience has taught us that maintaining the integrity of metadata throughout the chain is extremely difficult (it is difficult even to ensure correct audio visual sync!). In distribution only a single compressed 10 bit signal would be transmitted, to feed both SDR and HDR receivers rather than requiring a complex layered coding solution. Our proposal is based on relative brightness, in that same way as conventional television, which is both simple and, we believe, the correct approach for HDR TV.

A.2: Dolby Labs-Dolby Vision™

Dolby Vision™ is based on extensive research to identify the practical limits of the human visual system dynamic/color range for entertainment purposes and then develop a flexible, scalable, end-to-end solution to increase the capability of each pixel to represent more and brighter colors as well as increased dynamic range (aka “better pixels”). The research concluded a system which is capable of delivering content with a dynamic range from 0.001 to 10,000 nits, would satisfy the vast majority of viewers (~84%) on a range of consumer devices from tablets to very large TVs and even theatrical displays. However, for a dynamic range of 10,000 nits, gamma 2.4 does not accurately match the contrast sensitivity nonlinearity derived from the light-adaptive function of the human eye. Consequently, a new perceptually-based quantizer EOTF called PQ was developed following the contrast sensitivity function of the human eye as measured by Barten and referenced in Report ITU-R BT.2246-2 and subsequently standardized as SMPTE ST-2084. As for precision: For noise-free images such as animation, CGI, or graphics, using 12-bit PQ ensures that both monochromatic and color-banding artifacts are below the visible threshold. For natural images that contain some noise, using a 10-bit PQ representation is adequate, but care needs to be taken, especially with graphics. For simplicity, we refer to images with higher dynamic range/wider color gamut than SDR as Extended Dynamic Range (EDR). The Dolby Vision EDR system is based on the following criteria:

- 1) Single production workflow required for both SDR and EDR content.
- 2) Compatibility with existing real-time and non-real-time infrastructures and be independent of any spatial resolution, color gamut or frame rate.
- 3) The highest possible quality images, matching the creative intent, should always be available to the home viewer.
- 4) The transmission/delivery system should be bitrate efficient, use industry standard codecs without regard to pedigree and support backwards compatibility (BC) with BT.709, BT.2020, etc. as needed or non-backwards compatibility (NBC) where maximum efficiency is needed.
- 5) Devices must be capable of mapping the transmitted images to the device display’s native color volume to provide best image possible.
- 6) As image quality in both professional/consumer applications improves with display advances, the transmission system must not be the bottleneck and mastering solutions should be future-proof for archival purposes.

An end-to-end solution for off-line content creation embodying these criteria has been deployed. Dolby’s “Pulsar” professional reference display with a 4000 nit (D65)/P3 color volume, plus a set of plug-ins for off-line production suites, enable creatives to master in the largest available color volume. During EDR mastering, metadata is generated based on creative input. This metadata is used downstream to guide the display management in the consumer device. For backwards compatibility with BT.709, future BT.2020, etc., a dual-layer codec architecture has been developed which transmits existing standards as a BC base layer while an EDR Enhancement Layer (EL) provides information necessary to recreate the Dolby Vision EDR. This dual layer codec works outside of the coding loop so that no changes are required to legacy encoders or decoders. The solution works with any spatial resolution, bit depth, color primaries, and color volumes up to 10,000 nits for either an 8-bit AVC or an 8/10-bit HEVC base layer. 10- or 12-bit PQ inputs will be faithfully reconstructed at the dual decoder output. The Dolby Vision enhancement layer increases the bitrate by only ~20-25% above the backwards-compatible base layer. Dolby has also developed a single layer non-backwards compatible 10 bit solution for broadcast or OTT applications which provides even greater bitrate efficiency in use cases where backwards compatibility is not required and works with legacy dual layer decoder implementations.

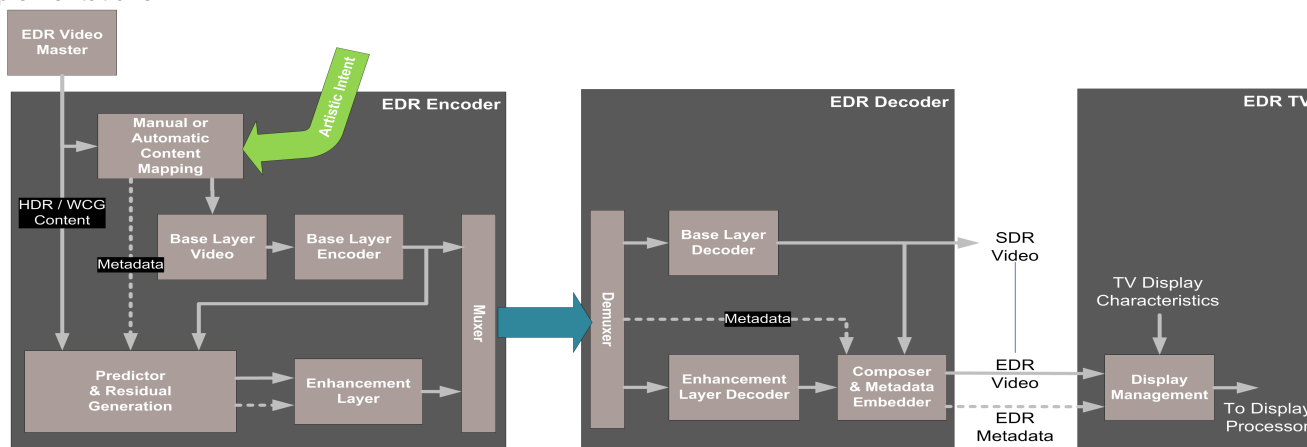

A.3: PHILIPS HDR - A parameter based HDR system

High Dynamic Range (“HDR”) video is seen by many as the main next step for improved immersive experience for the consumer. A new video standard is needed to convey HDR video from the studio to the consumer. A new HDR video standard must not only provide high quality HDR video, but also

- Allow low-cost decoding to enable adoption by CE industry
- Have minimal impact on existing transmission/storage channels, i.e. low additional bit rate compared to Standard Dynamic range (“SDR”) video
- Allow an efficient content creation workflow
- Address the wide variety of HDR displays that will be in the market

Not only high-end and mainstream TVs, but also tablets and even mobile phones must benefit from the optimum image from a single video stream. Our research shows that in practice this optimum result for a wide range of maximum brightness values can be derived from only two reference grades: a high brightness HDR grade (at the high end of the range) and an SDR grade (at the low end). These two grades are related. The difference between the two can be adequately captured with a set of parameters. HDR encoding can thus be realized by adding low bit rate information to one of the two video streams to allow the transformation of content to the optimal grade for any display peak luminance and dynamic range.

The functional block diagram below shows how the system works. The process starts from a HDR master video, graded on a reference HDR monitor (high brightness, low black levels).

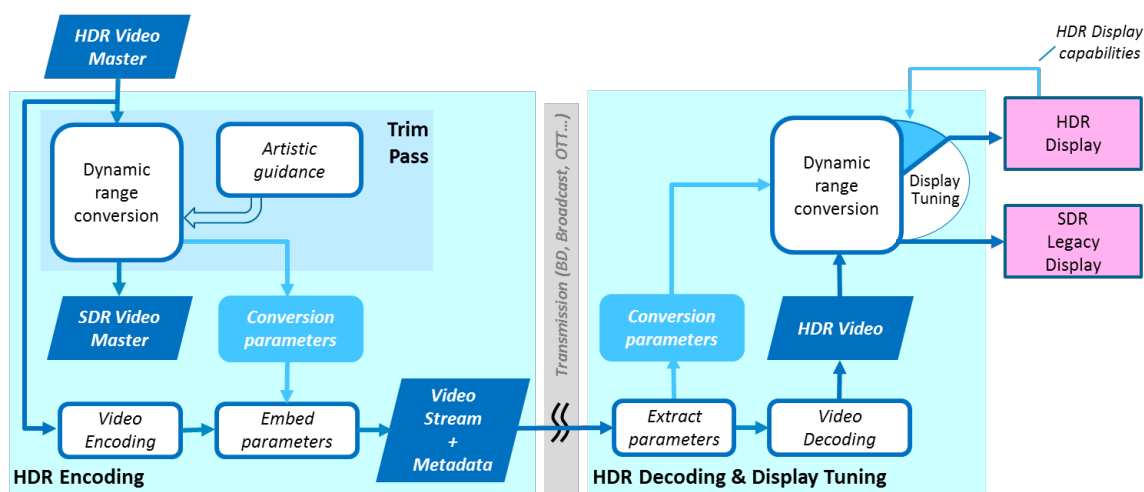

SDR video is derived in the encoder in a semi-automatic way: first an automatic tone mapping is proposed. Then a colorist adds corrections to optimize the SDR Master (typically on a scene-by-scene basis). The corrections are captured in parameters. If both an HDR and SDR grade are available, the parameters can also be calculated in an automatic process. The HDR video is encoded, transmitted and decoded using a standard 10 bits codec (e.g. HEVC). The grading parameters are added to the HDR video stream at the encoder and transmitted as dynamic metadata in SEI messages. The parameters are extracted in the decoder and used in combination with the decoded HDR video to apply a dynamic range conversion / tuning, optimized for the capabilities of the attached display, which may range from SDR to high performance HDR, or anything in between. For broadcast applications, the step of correcting the automatic tone mapping by a colorist may be omitted or replaced by a default correction, e.g. based upon a few presets.

The main characteristics of the Philips HDR system are: high quality HDR, single layer / single stream, very low additional bandwidth, 10-bit encode/decode, display tuning for any display peak luminance.

For highest quality, Y"u"v" pre-encoding can optionally be used, as well as the Philips HDR EOTF and corresponding OETF (submitted to ITU). There is also a compatible mode, where the SDR video plus parameters is transmitted and the decoder uses the parameters to up-convert the SDR video to HDR.

A.4: Samsung's Proposal on Dynamic Metadata

Scope: Samsung proposes a tone mapping method dubbed as “Scene-based Color Volume Mapping” in which dynamic metadata is defined for each scene (or clip) to best reproduce the creative intent of HDR contents as much as possible on displays with a smaller dynamic range and narrower color gamut

Proposed Tone mapping: The proposed method takes a practical approach to a real manufacturing limitation wherein the peak luminance of the mastering monitor changes with the average picture level (APL). It is noteworthy that the peak luminance defined in the SMPTE ST 2086 metadata does not represent the real peak luminance of the mastering monitor when the monitor's luminance is regulated by power consumption constraints. As such, depending on the APL, the real peak luminance of the mastering monitor may be less than the maximum content luminance level. Once this fact is taken into consideration, tone mapping based on static metadata will not be optimal and would result in artifacts in the displayed content.

Following figure demonstrates tone mapping wherein HDR content with 1000 nit and 60% APL is going to be displayed on a target display with 500-nit peak luminance. The curves in red and blue represent tone mapping based on SMPTE ST 2086 metadata and proposed method respectively. The difference (i.e. delta) between the two curves indicates the luminance values on the target display which are brighter than the HDR contents on the mastering monitor

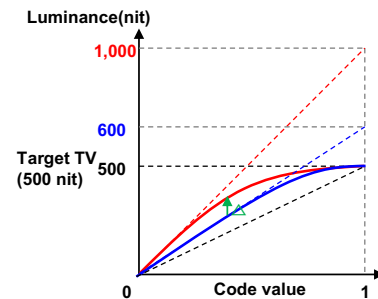

Proposed Color Saturation Mapping: The proposed method can compensate the saturation difference between an input and its tone-mapped result. The compensation is performed in a fully automatic way and can also be controlled by a user input parameter. The parameter is just a gain which allows colorists to adjust color saturation.

Metadata for Proposed Technology: The proposed technology, beside metadata from SMPT ST 2086, uses the following metadata: APL-based peak luminance characteristics of the mastering and the target monitors, and Scene-wise maximum of the color components {R,G,B}, Scene-wise average of maximum of color component values {R,G,B}, and Scene-wise area of the brightest pixels from HDR contents.

Two user control inputs: Tone Preserving Luminance, and Color Saturation Weight are used to tune the proposed tone mapping and color saturation mapping by colorists to their intention. Following figure shows the proposed signal pipeline.

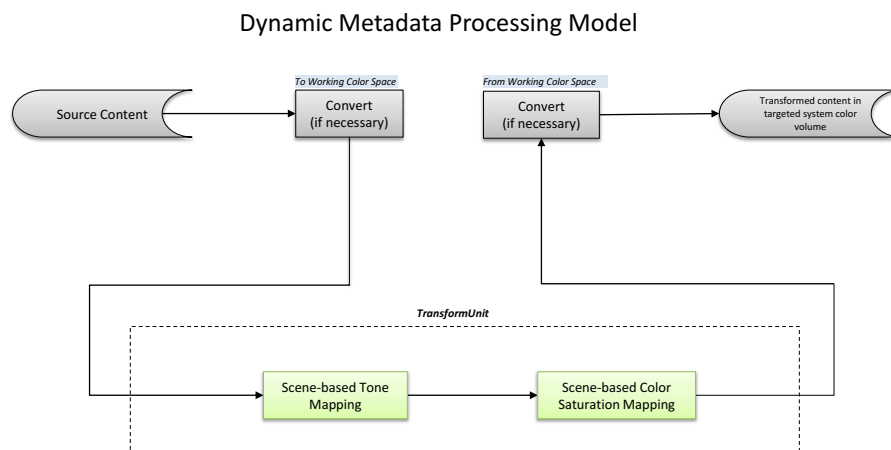

A.5: Technicolor: An HDR Home Video Mastering & Distribution Workflow

Technicolor proposes an efficient HDR workflow/ecosystem based on three pragmatic tenets:

- **Two Content Masters**, one graded to HDR and one to SDR, will be produced for the foreseeable future;
- **Efficiency** is critical to do as much with the available resources (e.g., bandwidth) as possible; and
- **Preservation of Artistic Intent** is not only possible, if only to maintain existing quality, but vital.

Figure 1 shows an end-to-end workflow supporting content production and delivery to HDR and legacy SDR displays. This HDR provision workflow is based on technologies and standards that facilitate an open approach, including a single-layer SDR/HDR HEVC encoding, the MPEG-standardized Color Remapping Information metadata (CRI) for HDR-to-SDR conversion, a Parameterized Electro-Optical Transfer Function (P-EOTF), and SHVC. This ensures that consumers at home experience what the filmmaker intended.

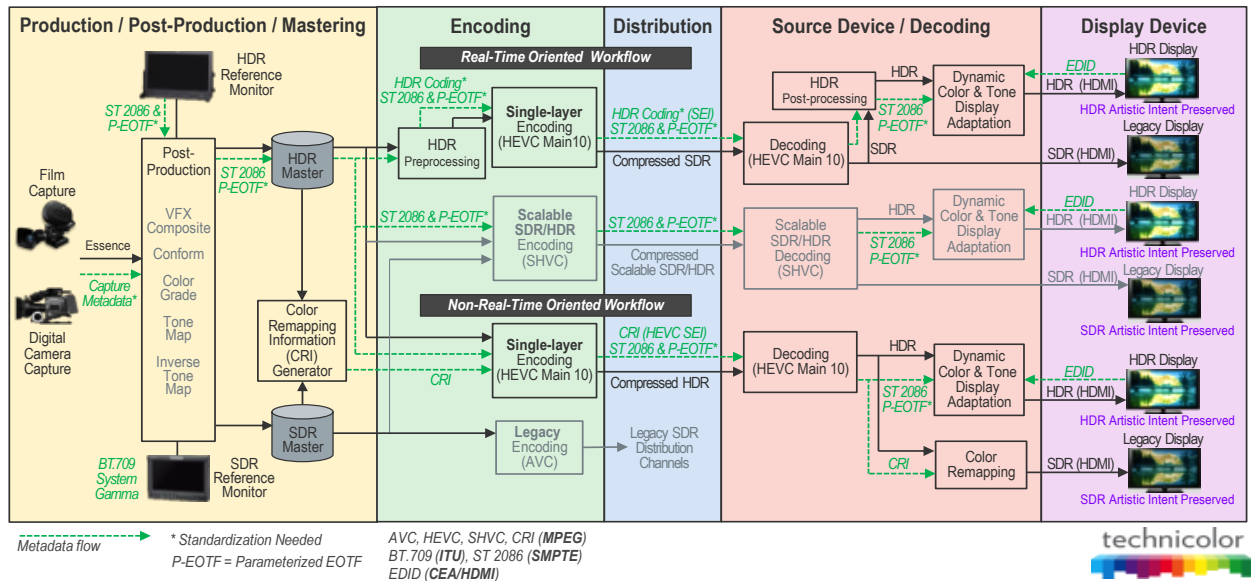

A-1: Technicolor HDR Ecosystem workflow

Figure

Technicolor identified three ways to deliver content in both HDR and SDR: (1) *backward-compatible* Single-layer SDR/HDR Encoding with mastering metadata, (2) Single-layer HDR Encoding with CRI to support SDR displays, and (3) a future Dual-layer Scalable SDR/HDR Encoding. Single-layer Encoding requires only one HEVC decoder in the player/display and supports the real-time workflow requirements of broadcast applications. For non-real-time applications, Single-layer HDR Encoding with CRI preserves quality and creative intent on HDR and SDR displays.

HEVC Version 2, standardized by the ITU-T/ISO/IEC JCT on video coding, specifies CRI carried in the HEVC stream as an SEI message to enable remapping of reconstructed color samples to match another grade having a different color gamut and dynamic range. The HDR grade(s) and SDR grade produced by content creators are available as input to a CRI Generator to produce the CRI. A CRI-capable source device (e.g., a UHD Blu-ray Player or Set Top Box) remaps the tone scale and color gamut of the HDR content to produce SDR output matching the artistic intent approved by the filmmaker in the SDR master.

Technicolor proposes that SMPTE consider standardization of a future-proof P-EOTF based on simple parameters and powerful enough to represent SMPTE ST 2084 and other EOTF curve shapes more suited for television as proposed by the BBC, NHK, and others.

Appendix B: HDR Tone Mapping Technologies

B.1: Academy Color Encoding System (ACES) for HDR and WCG Mastering:

ACES is a color management and image interchange framework for production, mastering, and long-term archiving of digital content. It is designed to bring images from multiple sources into a common color space and provide a standard approach for viewing the images across a wide variety of output devices, including high-dynamic range and wide-color gamut displays. ACES images are used as a 'digital negative' allowing high fidelity manipulation while output tone curves that limit the dynamic range are deferred to a set of 'virtual prints' for different output display capabilities. ACES serves the purpose of a Digital Source Master feeding distribution of mastered content into digital cinema, film exhibition, broadcast, and home entertainment.

The ACES system preserves all of the information captured by cameras through use of 16bit half-floating point values that cover 33 stops of dynamic range, more than double any existing camera encoding. The ACES color space (ST2065-1) covers the entire visible color gamut, and the primaries can be described as wide RGB primaries (not XYZ).

Images are converted into the linear-light ACES space with an input transform (IDT: Input Device Transform) that converts colors from the native camera response to a colorimetric encoding (ACES: also the name of the color space). Photographic exposures are referenced to a system design point -- a mid-grey value of 0.18 in ACES -- loosely representing the scene-referred color value of a properly-lit 18% grey card. ACES code values are equal to each other at the white point D60, a default which is considered more pleasing in theatrical presentations, but grading can change scene white balance to any value.

ACES images are viewed using an ACES Viewing Transform which provides an adjusted 'rendered' image appropriate for viewing in a dark-surround environment whether in the theater or at home. Production users may often select from a list of ACES Viewing Transforms that include other output devices (ODT: Output Device Transforms) which can also be software customized for different signal encodings, transfer functions, color spaces, white points, viewing surrounds, and dynamic ranges devices at 100 cd/m^2 , 600 cd/m^2 , and 1000 cd/m^2 .

For HDR production, ACES has a consistent set of viewing transforms based on S-shaped tone curves as seen in Figure B-1:

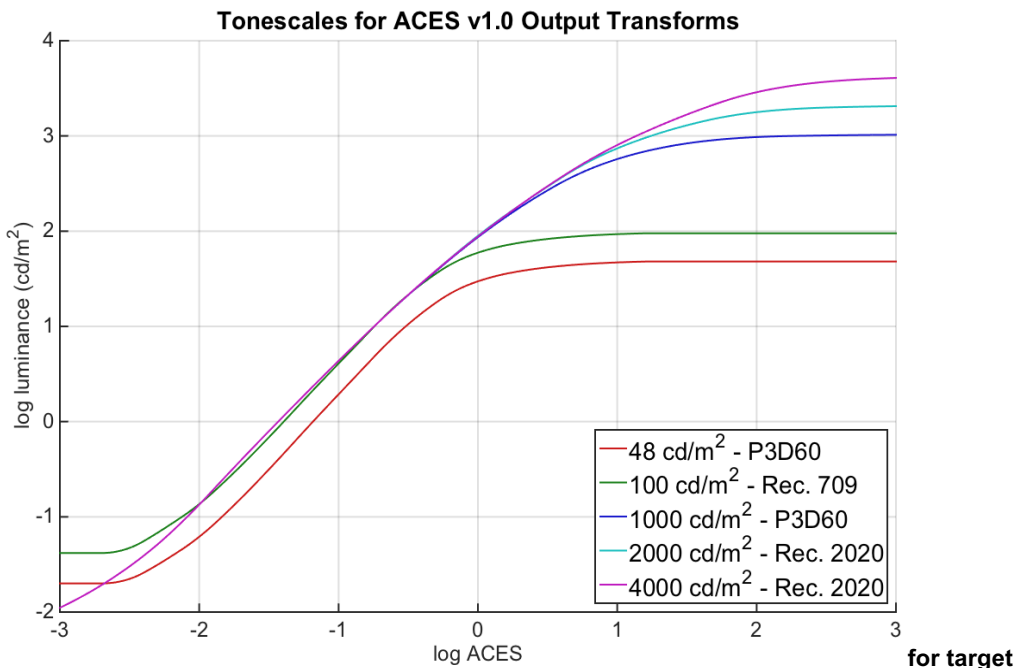

Figure B-1: ACES system tone curve

HDR masters can be quickly created for different dynamic range displays using a colorist graded ACES master. ODTs for different dynamic ranges have similar shapes, but the center of the curves are common to each other (though different for cinema than video), and content that is in the mid-tone region should look similar on different devices regardless of the extended highlight range or extended shadow range. Color space conversion from Rec.2020 to Rec.709 is handled in the ODT where ACES uses fairly simple techniques using tone curve compression and saturation adjustments. Corrections for dim surround, chromatic adaptation to D65, and corrections for shadow colors and the Hunt effect are included in the transforms. ACES ODTs for HDR at 1000 cd/m² 2000 cd/m² and 4000 cd/m² are present in the ACES v1.0 release distribution although tagged as 'for evaluation'.

ACES preserves a lot of flexibility for HDR and WCG production since the original image can be manipulated without compromising the dynamic range or color space coverage.

ACES 1.0 is described in SMPTE standards

- ST 2065-1:2012 Academy Color Encoding Specification
- ST 2065-2:2012 and ST2065-3:2012 Academy Printing Density and Academy Density Exchange Encoding (ADX)
- ST 2065-4:2012 ACES Image Container File Layout

plus other features described at www.oscars.org/aces

B.2: Disney Research - Temporally Coherent Local Tone Mapping of HDR Video

Presentation by Disney Research Zurich -- Tunç Aydın, Nikolce Stefanoski, Simone Croci, Markus Gross, Aljoša Smolić

Disney Research presented new technology for "Temporally Coherent Local Tone Mapping of HDR Video", recently developed in their Zurich Lab. A corresponding paper was published at SIGGRAPH Asia in December 2014. Tone mapping is the process of compressing images or video from a higher source dynamic range into a more limited target dynamic range. Such operations may be applied at different positions in the pipeline.

On the post production side, this may be done as part of a color grading process, where an artist creates a certain look, given captured or otherwise generated footage, for certain display conditions. Today's digital cinema cameras can capture dynamic ranges (f-stops) that are much larger than what can be shown on displays or in cinemas, whether HDR or not. At the display it may be or may become necessary in the future to map a received signal (e.g. HDR video) to the limited capabilities of a display (e.g. SDR). This may be an automatic or user-assisted process. Also it may become necessary to apply tone mapping for encoding, distribution, etc., incl. e.g. computation of base and enhancement layers for backwards compatible coding.

Tone mapping is an inherently non-linear operation on images or video that tries to preserve certain image characteristics (e.g. highlights, details in dark regions). A major difficulty of existing approaches is temporal inconsistency when applied to video, resulting in flicker or wobbling artifacts. Also, amplification of noise is known to cause problems. The presented algorithms overcome these problems by a novel approach based on spatio-temporal filtering. The source video is separated into a base layer and a detail layer by a novel edge-aware filtering method in spatial and temporal dimension. Temporal windows of a certain length are applied with optical flow. The layers can then be processed separately and recombined. For instance, the base layer can be compressed to a certain target dynamic range and details can be added back to preserve local contrast.

It was shown that even extreme looks can be achieved with this approach that would result in very annoying artifacts with any other tone mapping algorithm. A more subtle tone mapping can of course also be achieved as well without temporal artifacts. Additionally, noise reduction comes for free due to inherent spatio-temporal filtering. As such, the presented technology appears highly interesting for any of the application scenarios described above.

Appendix C: Possible HDR Interactions with the Human Visual System

There may be complex interactions between High Dynamic Range picture characteristics and certain attributes of the human visual system. This Annex reviews some of the possible issues that content producers may need to consider as they produce HDR program material.

HDR, Visual Adaptation, and Potential Interactions

Visual Science-

Introduction:

This contribution provides information related to adaptation of the human visual system to changes in luminance, particularly in the context of High Dynamic Range video. This information might be useful in addressing potential issues such as: sequential viewing of HDR and non-HDR content; maximum luminance; and preservation of creative intent.

Processes of Light and Dark Adaptation:

The human visual system adapts to 9 log units of light intensity. There are several physiological processes that are responsible for light and dark adaptation.

Pupil diameter:

Exposure to bright light can reduce the area of the pupil, and consequently reduce retinal illumination, by approximately a log unit in $\frac{1}{2}$ second. Although changes in pupil size account for a relatively small portion of visual adaptation, it is worth noting that reduction in pupil size also increases depth of focus and reduces glare. A 100-fold change in luminance (the intensity of light approximately 30-fold change in retinal illuminance (the total luminous flux per unit area incident on a surface)). Both screen luminance and ambient background should be considered when predicting pupil size and retinal illuminance. Note that some psychophysical studies use a naturally adapting pupil and thus explicit calculation of retinal illuminance need not to be performed to apply the results of such studies.

Shift from rod system to cone system:

It is well known that rods are responsible for night vision and cones for daylight and color perception, but it is more accurate to think of visual adaptation in three categories that better reflect the gradual shift from rod-dominated vision to cone-dominated vision as light conditions brighten: Scotopic (below 0.001 cd/m^2) dominated by rods; Mesopic (0.001 to 10 cd/m^2) mix of rods and cones; Photopic (above 10 cd/m^2) dominated by cones. In darkened cinema theaters and home environments, mesopic-level adaptation could be a significant consideration. In bright home and mobile environments, photopic-level adaptation would be more typical.

Bleaching Adaptation:

Vision is initiated by activation of light-sensitive photopigments. The concentration of excitable photopigment is reduced during sustained illumination in a process called bleaching adaptation. Sustained exposure to luminance over several thousand cd/m^2 can be expected to result in a significant fractional reduction (> 20%) in excitable photopigment concentration, which would reduce the optical density and light-sensitivity of retinal photoreceptors, and can result in the perception of after images.

Speed of Adaptation:

Photoreceptors adapt to moderate step changes in illumination on the time scale of seconds. During the light adaptation process, the absolute sensitivity of photoreceptors decreases and the kinetics of responses speed up. The time course of recovery of light-sensitivity depends on the intensity and duration of preceding stimulus. Following stimuli in which no significant photo pigment bleaching occurred, recovery of sensitivity can be expected to be on the time scale of seconds. For stimuli that result in significant fractional bleaching adaptation, recovery of sensitivity can be on the order of 10s of seconds to minutes. In bright home and mobile viewing environments, adaptation to modulations in illumination can be expected to proceed on a time scale measured in seconds. In dark home and theater environments, rapid changes going back and forth from mesopic-level to photopic-level luminance could result in slower adaptation and change of sensitivity.

Possible HDR Interactions:

HDR provides a wider range of luminance than legacy television and cinema. In some cases, the variations in luminance could be large enough and fast enough so as to deliberately, or inadvertently, affect a viewer's experience in ways that were not previously possible. Of particular concern is the avoidance of potentially negative experiences such as increasing the perception of flicker or decreasing the effectiveness of revenue-generating commercials.

Potential Effect of Luminance & Screen Size on Flicker Perception:

The ability to notice flicker increases with luminance (Should this be brightness??). The critical flicker frequency (CFF) is the temporal frequency at which flicker is perceived as a steady light. CFF may be predicted from luminance with the Ferry-Porter Law, which states that the CFF increases in proportion to the logarithm of luminance. Flicker sensitivity also increases with stimulus size in a predictable manner (Granit-Harper law). It could be important to consider the effect of frame rate and display refresh rates on the perception of flicker and judder, particularly for HDR displays and programming that deliver significant retinal illumination over a wide visual field.

Potential Effect of Luminance on Color Perception:

The ability to discriminate colors increases with luminance. Color discrimination can be described in terms of MacAdam ellipses, a measure of the just-noticeable difference (JND) between colors. The size of MacAdam ellipses shrinks with increased luminance, which means that the JND decreases. Luminance also affects the perception of the hue. The Bezold-Brücke effect describes the change in perceived hue as a function of luminance. It could also be important to consider the impact of localized as well as global increases in luminance on the perception of color.

Potential Effect of Speed of Adaptation on Scene Change, Program Change, and Commercials:

The speed of light and dark adaptation depends on the level of retinal illuminance, the duration of illumination, the kinetics of the changes in pupil size, the rate of change of photoreceptor sensitivity, the rate of change of excitable photopigment, and the state of overall visual adaptation (scotopic, mesopic, or photopic). It could be important to consider the impact of rapid local or global luminance changes on creative intent. It could also be important to consider the impact of significant luminance changes in television programming in which HDR and non-HDR content might be viewed sequentially, such as could be the case for commercial insertion or channel change.

References:

Several academic references could be useful in situations in which in-depth vision-science analysis of HDR and its possible interactions would be beneficial:

- 1) Alder's Physiology of the Eye, 11th edition;
- 2) Wyszecki & Stiles. Color Science: Concepts and Methods, Quantitative Data Formulae – Second Edition;
- 3) Watson, A.B. and Yellot, J.I. (2012) "A unified formula for light-adapted pupil size." *J. Vis* 12(10):12

Production Concerns:

Viewer perception of wide area flicker increases with angle of view, because the human visual system has a heightened sensitivity to low frequencies of screen illumination in the peripheral areas of the retina. Larger subtended viewing angles can be expected to be more prevalent with the larger screens supported by the very high UHDTV spatial resolution. At some point, there is a contrast threshold for visibility of wide area flicker, and since increased contrast will exist in HDR program material, care may need to be taken in certain peak levels to avoid triggering flicker visibility

Visibility of judder is another issue to be considered. One form of judder arises when the viewer's eye tracks moving scenes or objects according to an expected motion path at its average velocity, while frame repetition in the display presents moving elements out of their "expected" position on the retina (perhaps lagging behind where the viewer "expects" it to appear). This is common when an original sequence of 24 Hz images are repeated to match a higher display refresh rate). With HDR content, image elements at a high peak luminance may trigger visibility of judder artefacts that would not be seen in the low and mid-tone regions of the images. Content producers may need to moderate HDR peak levels to be in line with the frame rate in use, adjust shutter angle to create motion blur that may mask judder visibility, or limit high-key image movement or panning speeds.

Other issues may need to be considered with HDR material. Experience in HDR image acquisition and post-production grading may yield solutions to the following possible complications:

Edit pace may need to be different in HDR versions than SDR versions, since fast cuts with high brightness elements may cause viewer eye strain.

Though not desirable as a matter of production effort, HDR content might conceivably benefit from custom tailoring for the small screen and the large screen, due to expected differences in eye-tracking. This may need to be investigated.

Cross-dissolves and fades out and in will appear differently in HDR material. Bright highlights will appear sooner, and disappear later, then with dissolves and fades with Standard Dynamic Range material

Limits in the speed of human visual system's adaptation to overall brightness changes may require producers to either avoid, or perhaps prepare the viewer for abrupt changes in average picture level or the presence of multiple HDR highlight elements. In other words, viewers' eyes might need to be adjusted slowly, in advance, via a progression in scene brightness, for a known, large upcoming change in picture or highlight brightness. This may be of particular importance when moving from high brightness to low, where the eye's speed of adaptation is much slower than from low to bright.

After-images from preceding highlights may impair visibility of following dark scenes, especially if these scenes are at unusually low brightness levels in dark viewing environments, as is within the capabilities of HDR systems.

Appendix D: Technical Options-reference material

This section of the report is a collection of materials submitted by proponents. This material may not be current at the time of publication. The text contained within the proposals is that of the proponents and not the findings of the Study Group.

D.1: PHILIPS HDR – u'v' chromaticity option

Traditional Y'C_BC_R is adequate for moderate dynamic range and color gamut, but its disadvantages become apparent in High Dynamic Range video with Wide Color Gamut. Most prominent are:

- Quantization artefacts that may result in visible banding
- Color errors due to 4:2:0 subsampling

These Y'C_BC_R performance issues for HDR/WCG video are related to the larger size of the HDR/WCG color volume, and to the very non-linear behavior of an HDR EOTF. Both issues can be tackled by an alternative color representation, using (u'v') chromaticity components [ref. 1], defined by $u' = \frac{4 \cdot X}{X + 15 \cdot Y + 3 \cdot Z}$, $v' = \frac{9 \cdot Y}{X + 15 \cdot Y + 3 \cdot Z}$.

Quantization artefacts

The u'v' chromaticity differs from C_BC_R color difference in a more uniform color space, and decoupling of luminance and perceptually uniform color space means that a simple linearly can be used, that the quantization errors will be uniform over color space, and that the available code words can be used effectively. The decoupling of luminance and color means components do not have to represent the large dynamic HDR video signal. It can be shown that quantization artefacts banding become invisible at a bit depth of around 9 bits for components, while 12 bits would be needed for HDR/WCG components.

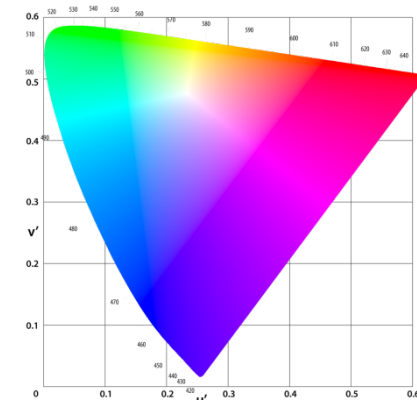

perceptually color. A quantization the whole more that the u'v' range of the such as the u'v' C_BC_R

Color errors due to 4:2:0 subsampling

The known non-constant luminance effects of Y'C_BC_R more apparent with HDR video, because of the stronger non-linearity of an HDR EOTF compared to Recommendation ITU-R BT.1886 gamma. If we try to mix dark and bright colors in the C_BC_R domain then we'll see an unjustifiable dominance of the dark colors, leading to strong color artefacts.

Y''u'v' is however a true Constant Luminance solution, and 4:2:0 sub-sampling works well for an optimized order of operations [ref. 2]. Specifically, the low-pass filtering for the color down-sampling must be done on linear-light signals RGB or XYZ. After up-sampling in the receiver the result comes close to the original 4:4:4 signal. See the image below, where the left half of each picture is an original, the right half is after conversion to 4:2:0 and back.

	<i>Dark blue and lighter grey</i>		<i>Light blue and very dark grey</i>	
	<i>Original</i>	<i>Processed</i>	<i>Original</i>	<i>Processed</i>
Mix in (Y'', C _B , C _R) (HDR OECF)				
Transmit (Y'', u'', v'') (HDR), mix in (X, Y, Z)				

In order to improve the behavior of MPEG video encoders that are optimized for coding Y'C_BC_R signals, Philips proposes a slight variation of u'v', denoted u''v'', where for very low luminances the u'v' are scaled down. Compared to other schemes that have been proposed, a Y''u''v'' 4:2:0 transmission signal for HDR promises a lower bit-rate, better color reproduction at high spatial frequencies, less noise at 100% color saturation, and full coverage of the entire humanly visible color gamut

References

1. CIE S 014-5 (2004), Colorimetry, Part 5, CIE 1976 $L^*u^*v^*$ Colour Space and u' , v' Uniform Chromaticity Space. Also published as ISO 11664-5:2009.
2. Charles Poynton, Jeroen Stessen, Rutger Nijland: "DEPLOYING WIDE COLOUR GAMUT AND HIGH DYNAMIC RANGE IN HD AND UHDTV", IBC 2014

Appendix E: Case Studies

E.1: “Emma” an HDR Case Study²

(May-October 2014)

Introduction-

Emma is a thirteen-minute short film, written by Rod Bogart, designed with High Dynamic Range (HDR) in mind from the start of the process. It is a 1960's period piece that takes its tone from the TV series Alfred Hitchcock Presents. It takes place on a stormy night in the country where our main character, Edward Taylor is asked to help his boss in finding his missing wife, Emma, only to realize that instead he has to face his very own demons.

Emma was produced by Andrea Dimity, shot by DP Daryn Okada and directed by Howard Lukk over the course of 4 days in the May/June 2014 time frame. The goal was to create a compelling short film that could take advantages of HDR. Emma was composed in the Scope (2.39:1) aspect ratio, shot at 24 Hz and designed for theatrical release. The specific desire was to have great range in the dark areas of scenes to amplify the tension of the story.

It starts with a driving shot at sunset as Edward approaches the door of an old Victorian house as night falls.

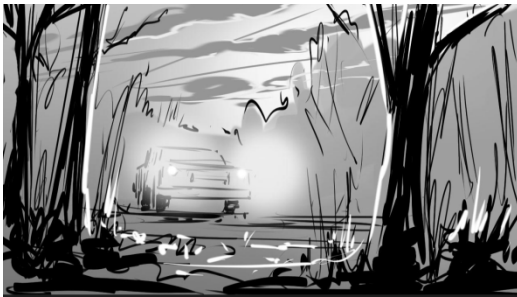

Once inside the story begins to unfold as a medium arrives and a séance begins in the dark with just the candles to light the way.

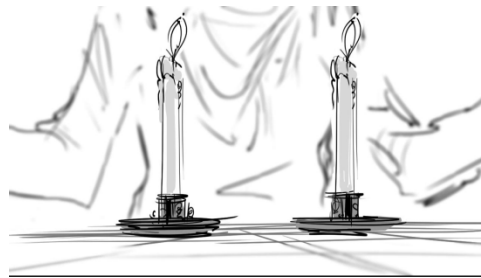

² Reference to commercial products does not constitute endorsement by the Study Group.
© 2015 by Society of Motion Picture and Television Engineers® (SMPTE®) – All Rights Reserved.

The storm outside intensifies and soon we see lighting strikes and strange things begin to happen.

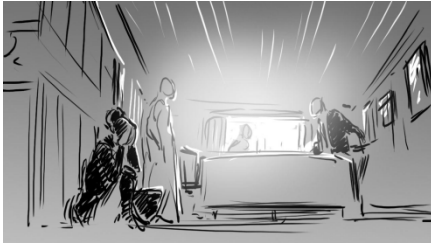

Production-

Emma was shot with a single ARRI Alexa XT using their Open Gate technology to make maximum use of the sensor while capturing the images. (3414x2198 12b RAW) Zeiss Compact Prime (CP2) lenses were used along with the Alexa that has approximately 14 stops of dynamic range. At the time Emma was shot, this was only one of two digital motion picture cameras commercially available with this amount of dynamic range. The images were recorded to the onboard Codex recorder with both High Speed and non Standard cards.

Special care was taken with lighting, however at the time of the shoot there were no commercially available displays to view HDR on. So a traditional Sony HD monitor and Leader scope were used to set and adjust camera and lighting. Daryn used a light meter extensively along with the other tools above and commented we were going to be shooting this “just like film”.

Dallies were generated by ColorFront’s On Set Dallies (OSD) system which created DNxHD 175x files to be used for editorial and preview screenings. A standard ARRI lookup table was used and worked well due to the excellent work done by Daryn.

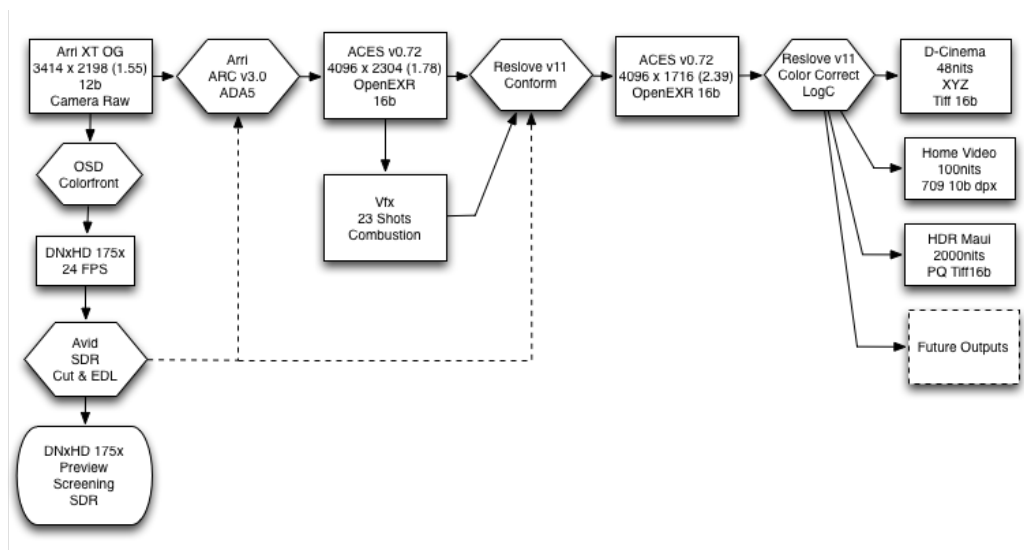

Post Production-

The DNxHD files were loaded onto an Avid workstation and the 4.2 TB of ARRI RAW files were stored for later processing. A couple of versions were made and previewed in a digital cinema review room (Digi-Review) provided by Disney Digital Studio Services (DDSS). At the time there was no commercially available HDR projectors so all viewing done for editorial and previews were seen at standard levels.

Test frames were sent out to the Vfx vendor to confirm that the pipeline supported 16b OpenEXR frames. The vendor did a composite shot on the frames and returned them to verify that it would not compromise the HDR frames.

Once picture lock was established, selected ARRI RAW files were pulled and converted to 4096x2304 16b ACES v0.72 OpenEXR files. These files were sent to the Vfx vendor to composite 23 shots. Vfx turnovers were converted to DNxHD and were reviewed on the Digi-Review Room. Once all shots were finalized then these were dropped into the final editorial version and a locked and final EDL was created.

Using the final EDL, pulls of all frames were accomplished by converting the ARRI RAW files using ARRI's ARC v3.0 ADA5 software to create the OpenEXR files to match the Vfx frames. (same format as stated above) These final frames were then conformed at 4k using DaVinci's Resolve v11 into 4096x1716 16b ACES v0.72 OpenEXR frames. A 4k DCP was created to review the conformed content without titles and once again screened at the Digi-Review Room.

In parallel Title Graphics were created by DDSS for the Main Title and the End Credits.

The final non-color corrected conformed frames were then shipped to ARRI Film and Television in Munich, Germany where Florian (Utsi) Martin performed color correction using DaVinci Resolve v11. The files were converted to ARRI LogC and color correction began.

Due to scheduling the Theatrical version was the first pass. (Digital Cinema, 48 cd/m²). Windows were used to isolate particular items in shots, such as; a bright interior window, the car against the sunset and other areas to balance out the scene. This took approximately one day to complete with some trims the following day.

Once this pass was completed then we moved to another suite to perform the Home Video (HD 100nit) version on a professional monitor. With this pass completed then an HDR grade was done using a prototype 25" Dolby HDR display adjusted for 2000 cd/m² peak luminance using a PQ transfer function. All of these grade files were then taken back to the conform suite (The directors spare bedroom) where they were applied to the final frames, title graphics were added and rendered out for their different distributions. A DCDM was sent to DDSS which made the final DCP.

After the initial color correction was complete, there were some other experimental color corrections using the ARRI grade as the baseline using Resolve for a Home Video HDR version. This grade was baked in to the frames and another experimental grade was done in theatrical environment in HDR using a prototype HDR projector provided by Dolby. These were done at 2k resolution and were screened for a private demo.

Findings

1. To date there is no theatrical grade in HDR for the complete composition, which was one of the main goals of the project. Most of this is due to the fact that this production has run way ahead of the display equipment specifically the projection display devices.
2. Also to date there is no Home Video HDR version that will play on multiple manufactures displays. This is due to the fact that there is no standard and ecosystem to deliver this to. It can be shown in a closed ecosystem but needs to be color corrected specifically for each different display and viewing environment.
3. The lack of commercial displays makes it harder on set to provide lighting that is suitable for HDR content. As such choices are made "in the blind" as was done in traditional film production. This is not a huge problem in my opinion but would be greatly improved on with such a display on set.
4. Lack of standards (luminance level, transfer function, black level) for HDR display devices and its ecosystem is probably the biggest issue facing filmmakers at this moment. Without standards one must provide a separate color corrected version for each HDR ecosystem.

5. Ambient light level in the color correction suite is even more critical with HDR content, especially when trying to make use of the extended range in the black region of the image.
6. On a positive note, using ACES for the color encoding method really helped maintain consistent color through the Visual Effects pipeline. It will be a great benefit when manufactures adopt ACES 1.0 now released into their products and workflows.
7. Again Theatrical Scope (2.39:1) aspect ratio content suffers when distributed in the new UHDTV-1 format. One must either; "letterbox", "crop" or "pan and scan" from 4096x1716 to 3840x2160.

In conclusion, this project gave us a lot of insight into creating content for HDR. We were too early in the process but the good news is that we can always go back and color correct our original frames to the upcoming ecosystems.

Howard Lukk
12 January 2015

E.2 Blu-Ray™

E.2.1 Ultra HD Blu-Ray™ Video Characteristics

Video Codec	HEVC ⁽¹⁾		AVC
Spatial Resolution	3840x2160	1920x1080	1920x1080
Picture Format Aspect Ratio	16x9		
Bit Depth - SDR	10		8 ⁽²⁾
Color Space Primaries	Recommendation ITU-R BT 2020 ⁽³⁾ Recommendation ITU-R BT.709 (SDR only)		Recommendation ITU-R BT.709 (SDR only)
Color Sub Sampling	4:2:0		
Frame Rates	23.976p, 24p, 25p ⁽⁴⁾ , 50p ⁽⁴⁾ , 59.94p, 60p		23.976p, 24p
Peak Video Bit Rate ⁽⁵⁾	100Mbps		40Mbps
Bit Depth - HDR	10		N/A
HDR EOTF	SMPTE ST 2084		
Static Metadata	SMPTE ST 2086, MaxFALL (HDR only) ⁽⁶⁾ , MaxCLL (HDR only) ⁽⁶⁾		

(1) Main 10 High Tier Level 5.1. NOTE: in the mandatory part, HDR content is transmitted using a single layer codec with metadata in SEI messages.

(2) AVC 8-bit Recommendation ITU-R BT.709 SDR is allowed only for 1080/23.976p and 1080/24p frame rates and with a peak bit rate that is within existing BD specification

(3) BT.2020 uses the YC_BC_R non-constant luminance format

(4) Decoding 25Hz and 50Hz video is BD-ROM Player mandatory if a 50Hz TV system is used

(5) Peak Video Bitrate is constrained by the relevant ISO/IEC HRD conformance and by the MPEG-TS T-STD decoder buffer input rate

(6) See following text and figs for description of Static Metadata

including MaxFALL and MaxCLL values.

NOTE:

BDA Authoring Guideline for HDR Content will be prepared to include the following recommendation text: "Maximum Frame Average Light Level" not to exceed 400nits. Over 1000 nits should be limited to specular highlights which are expected to be a small percentage of the picture area.

SD resolution and 3D (MVC) video are not included. HDR Video optional technologies from Dolby, Philips and Technicolor are optional for content and optional for player. If Optional HDR technologies are included with content, the Mandatory HDR format must also be present with the content. See following slides for description of HDR Video optional technologies.

SMPTE ST 2084 : High Dynamic Range Electro-Optical Transfer Function of Mastering Reference Displays

SMPTE ST 2086: Mastering Display Color Volume Metadata Supporting High Luminance and Wide Color Gamut Images

E.2.2 Ultra HD Blu-ray™ - Static Metadata

E.2.2.1 Video Characteristics

The Ultra HD Blu-ray™ Video Characteristics allow content to be authored using a wide color gamut (encoded for BT.2020 Color Primaries) and also a large luminance dynamic range (encoded for ST. 2084 EOTF). This potentially large encoding space may not be fully used by the encoded authored content and is likely to vary title by title for various reasons. Static Metadata may be included with the authored content to describe the possible range of colors and dynamic range that are used by each encoded content.

E.2.2.2 Mastering Display Color Volume

SMPTE ST2086 “*Mastering Display Color Volume Metadata supporting High Luminance and Wide Color Gamut Images*” will be used to describe the capabilities of the display used to master the content, which includes the CIE (x,y) chromaticity coordinates of the RGB Primaries and White Point of the mastering display, in addition to the minimum and maximum luminance of the mastering display. If traditional mastering practices are followed during content creation, the range of colors and luminance values encoded in the mastered video signal will be limited to the range of colors and luminance values that can be shown on the mastering display. ST2086 may be included in the encoded stream for both SDR and HDR contents

E.2.2.3 Maximum Frame--Average Light Level

The Maximum Frame--Average Light Level (MaxFALL) is an additional Static Metadata item that applies to HDR Content only. HDR Content for Blu-ray Format Extension will be created while considering the authoring guideline that the Maximum Frame--Average Light Level not to exceed 400 nits. The Maximum Frame-Average Light Level corresponds to the highest frame--average brightness per frame in the entire stream.

E.2.2.4 Maximum Content Light Level

The Maximum Content Light Level (MaxCLL) is an additional Static Metadata item that applies to HDR Content only. Maximum Content Light Level corresponds to the brightest pixel in the entire stream.

E.2.2.5 BDA

BDA has previously requested that CEA and HDMI update their respective interface specifications to support sending Static Metadata (SMPTE ST 2086, MaxFALL, MaxCLL) from the player to a connected display.

E.2.3 Maximum Content Light Level (MaxCLL)

E.2.3.1 Maximum Content Light Level (MaxCLL) calculation

```
CalculateMaxCLL()
{
    set MaxCLL = 0
    for each (frame in the sequence)
    {
        set frameMaxLightLevel = 0
        for each (pixel in the active image area of the frame)
        {
            convert the pixel's non-linear (R',G',B') values to linear values (R,G,B) calibrated to
            cd/m2
            set maxRGB = max(R,G,B)
            if( maxRGB > frameMaxLightLevel )
                set frameMaxLightLevel = maxRGB
        }

        if( frameMaxLightLevel > MaxCLL )
            set MaxCLL = frameMaxLightLevel
    }
    return MaxCLL
}
```

E.2.3.2 Maximum Content Light Level (MaxCLL) information

For MaxCLL, the unit is equivalent to cd/m^2 when the brightest pixel in the entire video stream has the chromaticity of the white point of the encoding system used to represent the video stream. Since the value of MaxCLL is computed with a $\text{max}()$ mathematical operator, it is possible that the true CIE Y Luminance value is less than the MaxCLL value. This situation may occur when there are very bright blue saturated pixels in the stream, which may dominate the $\text{max}(R,G,B)$ calculation, but since the blue channel is an approximately 10% contributor to the true CIE Y Luminance, the true CIE Y Luminance value of the example blue pixel would be only approximately 10% of the MaxCLL value.

E.2.4 Maximum Frame Average Light Level

E.2.4.1 Maximum Frame Average Light Level (MaxFALL) calculation

```
CalculateMaxFALL()
{
    set MaxFALL = 0
    for each (frame in the sequence)
    {
        set runningSum = 0
        for each (pixel in the active image area of the frame)
        {
            convert the pixel's non-linear (R',G',B') values to linear values (R,G,B) calibrated
            to cd/m2
            set maxRGB = max(R,G,B)
            set runningSum = runningSum + maxRGB
        }

        set frameAverageLightLevel = runningSum / numberOfPixelsInActiveImageArea

        if( frameAverageLightLevel > MaxFALL )
            set MaxFALL = frameAverageLightLevel
    }
    return MaxFALL
}
```

E.2.4.2 Maximum Frame Average Light Level (MaxFALL) information

For MaxFALL, the unit is equivalent to cd/m^2 when the maximum frame average of the entire stream corresponds to a full-screen of pixels that has the chromaticity of the white point of the encoding system used to represent the video stream. The frame-average computation used to compute the MaxFALL value is performed only on the active image area of the image data. If the video stream is a "letterbox" format (e.g. where a 2.40:1 aspect ratio is put inside a 16:9 image container with black bars on the top and bottom of the image), the black bar areas are not part of the active image area and therefore are not included in the frame-average computation. This allows the MaxFALL value to remain an upper bound on the maximum frame-average light level even if image zooming or pan/scan is performed as a post-processing operation.

E.2.5 MaxCLL and MaxFALL representation

The MaxCLL and MaxFALL values can be represented as an unsigned 16-bit integer value in units of 1 cd/m^2 , where 0x0001 represents 1 cd/m^2 and 0xFFFF represents 65535 cd/m^2 .

If for some reason the MaxCLL and/or MaxFALL values are unknown, the value 0x0000 can be used to represent unknown.

E.3 BBC Hybrid Log-Gamma

Hybrid Log-Gamma Live Production, 9 July 2015

Richard Salmon and Simon Thompson, BBC R&D

In order to prove the suitability of the BBC/NHK Hybrid Log-Gamma system for live HDR TV production a short experimental live shoot was made in the BBC “One Show” studio at New Broadcasting House in London. The “One Show” is the BBC’s flagship early evening magazine programme.

The Test Shoot used two Sony F55 4k cameras, loaded with the BBC/NHK Hybrid Log-Gamma OETF as a “User Gamma”, illustrated below.

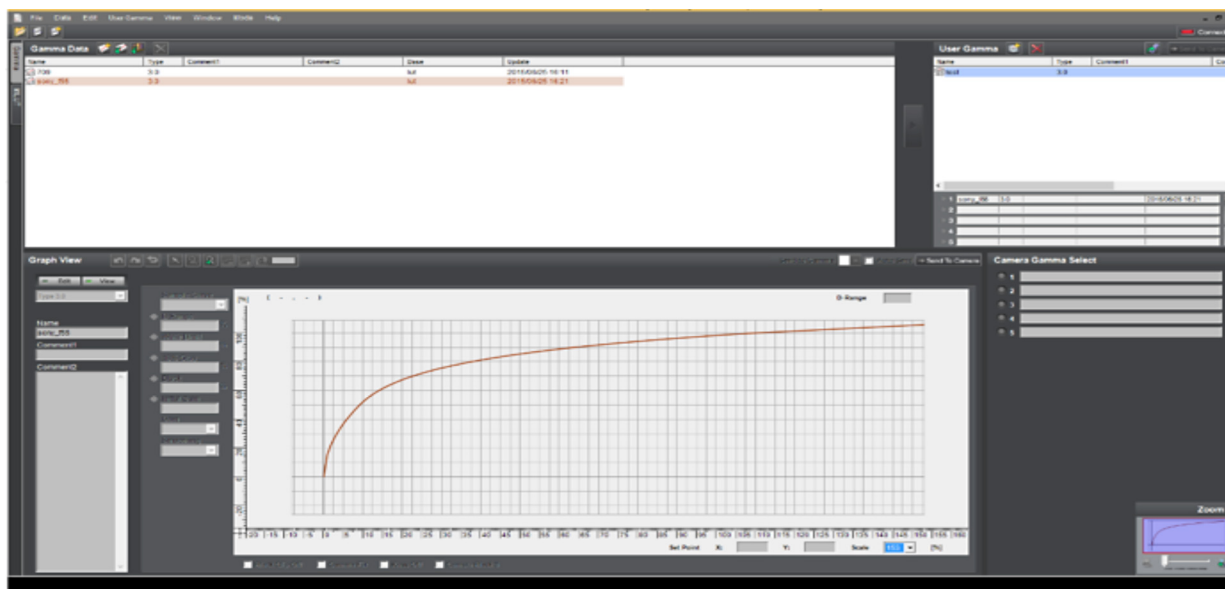

The cameras were locked using an external sync input, and externally racked using an RCP (Remote Control Panel).

A 1080p50 video player was used as an additional video source, replaying a pre-recorded BT.709 standard dynamic range (SDR) insert in to the HDR TV programme. The SDR BT.709 material was re-mapped to the Hybrid Log-Gamma OETF using an SDR Scene Light Conversion to hybrid log-gamma technique developed by the BBC.

The figure on the following page shows the system used.

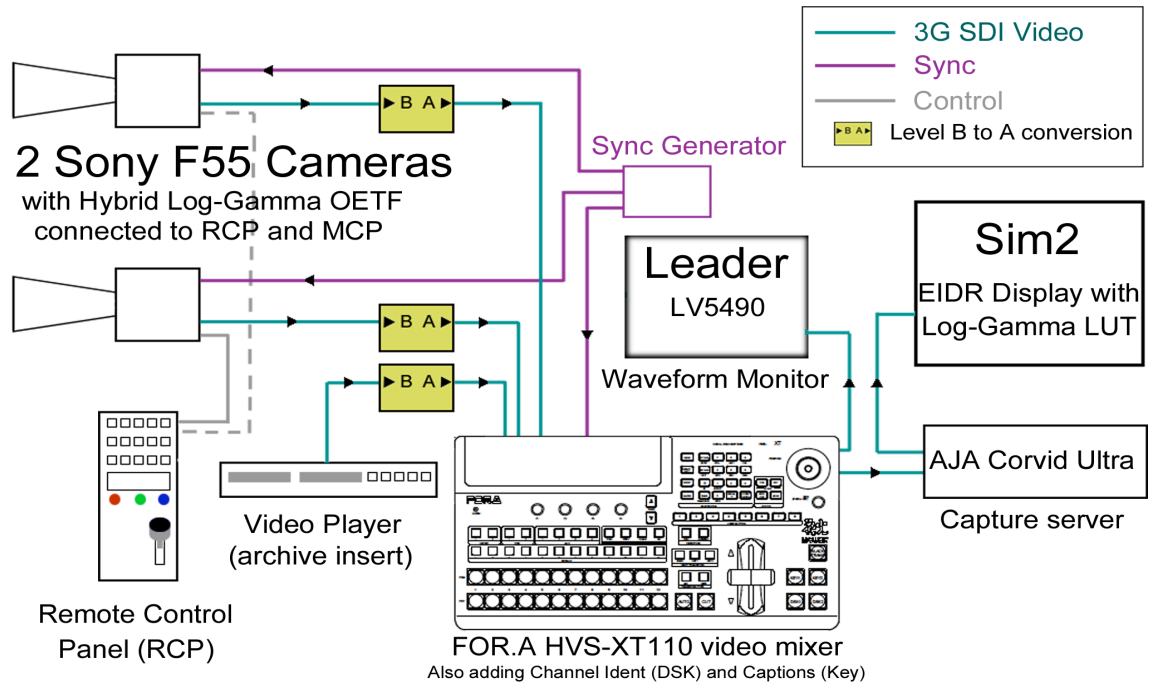

The cameras, Leader LV5490 waveform Monitor, the AJA Corvid Ultra capture server, and the FOR.A HVS-XT110 mixer were all capable of 2160p50 operation, transparent to the Hybrid Log-Gamma OETF, and although all the components, and the complete chain, were proved transparent to HLG signals at 2160p50, the HLG shoot itself was conducted in the 1080p50 format

The video mixer was also used to add a channel ident (DOG/Digital onscreen graphic), caption, and closing credits. In the production environment, all monitoring was conducted on conventional standard dynamic range displays fed with the Hybrid log-gamma signal, taking advantage of the compatible nature of the signal. The images were not viewed on the Sim-2 HDR screen until after capture.

Audio was captured and mixed live in the studio, including mixing in audio from the BT.709 SDR insert.

A demonstration of the recorded HDR TV programme was given during the 13th – 17th July 2015 meetings of ITU-R WP6C. The HDR image was shown on a SIM2 display and the compatible SDR image was shown alongside on a consumer SDR TV. Two photographs from the test shoot are included below.



One of two Sony F-55 cameras and the studio set with windows to the bright outdoors



The temporary HDR production gallery

Annex F: Works/ Standards Cited³

- a. To date there is no theatrical grade in HDR for the complete composition, which was one of the main goals of the project. Most of this is due to the fact that this production has run way ahead of the display equipment specifically the projection display devices. Essential Parameter Values For The Extended Image Dynamic Range Television (Eidrtv) System For Programme Production
http://www.arib.or.jp/english/html/overview/doc/2-STD-B67v1_0.pdf
- b. White Paper Blu-ray Disc™ Read-Only Format (Ultra HD Blu-ray™) Audio Visual Application Format Specifications for BD-ROM Version 3.0 July 201
http://www.blu-raydisc.com/assets/Downloadablefile/BD-ROM_Part3_V3.0_WhitePaper_150724.pdf
- c. ITU-R. Recommendation BT.709-5: Parameter values for the HDTV standards for production and international programme exchange. 2002.
<http://www.itu.int/rec/R-REC-BT.709/en>
- d. ITU-R. Recommendation ITU-R BT.2020: Parameter values for ultra-high definition television systems for production and international programme exchange .
<http://www.itu.int/rec/R-REC-BT.2020-1-201406-l/en>
- e. ITU-T. Recommendation ITU-T H.264 (V9) (02/2014). Advanced video coding for generic audiovisual services
<http://handle.itu.int/11.1002/1000/12063>
- f. ITU-R. Recommendation BT.1886 (03/11): Reference electro-optical transfer function for flat panel displays used in HDTV studio production. 2011.
<http://www.itu.int/rec/R-REC-BT.1868/en>
- g. ITU-R. Recommendation ITU-R 601 Studio encoding parameters of digital television for standard 4:3 and wide screen 16:9 aspect ratios.
<http://www.itu.int/rec/R-REC-BT.601/en>
- h. ITU-T. Recommendation ITU-T H.265 V3 (04/2015) High efficiency video coding.
<http://handle.itu.int/11.1002/1000/11885>
- i. EBU – TECH 3321, EBU guidelines for Consumer Flat Panel Displays (FPDs), Annex A, 2007
<https://tech.ebu.ch/publications/tech3321>.
- j. ITU-R. Recommendation ITU-R BT,2035 A reference viewing environment for evaluation of HDTV program material or completed programmes
<http://www.itu.int/rec/R-REC-BT.2035/en>
- k. SMPTE RP 431. D-Cinema Quality Reference Projector and Environment
<http://standards.smpie.org/content/978-1-61482-243-1/rp-431-2-2011/SEC1.body.pdf+html>

³ Access to some material may require fees.

- I. CIE S 014-5 (2004), Colorimetry, Part 5, CIE 1976 L*u*v* Colour Space and u', v' Uniform Chromaticity Space. Also published as ISO 11664-5:2009
http://www.iso.org/iso/catalogue_detail.htm?csnumber=54079
- m. American Society of Cinematographers Color Decision List (ASC-CDL)
https://www.theasc.com/ac_magazine/September2009/CASPart2/page4.ph
- n. Perception in Complex Fields. C. J. BARTLESON and E. J. BRENNEMAN ... 57,; Issue 7,; pp. 953-956; (1967);
•doi: 10.1364/JOSA.57.000953
<https://www.osapublishing.org/josa/abstract.cfm?uri=josa-57-7-953>
- o. SMPTE Report of the UHDTV Ecosystem Study Group
<https://www.smpte.org/standards/reports>

Annex G: Bibliography

1. Timo Kunkel, Erik Reinhard, A reassessment of the simultaneous dynamic range of the human visual system. Proceedings of the 7th Symposium on Applied Perception in Graphics and Visualization. ISBN 978-1-4503-0248-7 , pp. 17–24. July 2010.
2. Charles Poynton. Digital Video and HD. Morgan Kaufmann; 2nd edition edition (2 Dec 2012). ISBN-13: 978-0123919267
3. Moore, T.A. 1974. Digital Video: The number of bits per sample required for reference coding of luminance and colour-difference signals. BBC Research Department Report. BBC RD 1974/42.
4. Alan Roberts. 2009. Circles of Confusion. EBU technical. European Broadcasting Union. ISBN 2839905744, 9782839905749
5. Stevens, S. S. On the psychophysical law. Psychological Review, Vol 64(3), May 1957, 153-181. doi: 10.1037/h0046162
6. Rieke F, Rudd M.E. The challenges natural images pose for visual adaptation. Neuron. 2009 Dec 10;64(5):605-16. doi: 10.1016/j.neuron.2009.11.028
7. Davson H (1990) Physiology of the Eye, 5th ed. London: Macmillan Academic and Professional Ltd. J03691
8. Kodak. Basic Sensitometry and Characteristics of Film.
http://motion.kodak.com/motion/uploadedFiles/US_plugins_acrobat_en_motion_newsletters_filmEss_06_Characteristics_of_Film.pdf
9. Glenn Kennel. 1994, Digital Film Scanning and Recording: The Technology and Practice. SMPTE J. 1994, 103:174-181. doi: 10.5594/
10. Thomson Multimedia. 2003. The FilmStream Interface of the Viper FilmStream Camera. Available at http://www.cinematography.net/Files/filmstream_spec.pdf
11. Sony. 2009. S-Log White Paper. www.sony.co.uk/res/attachment/file/66/1237476953066.pdf
12. John Galt, James Pearman. 2007. Panavision Panalog Explained.
http://www.panavision.com/sites/default/files/docs/documentLibrary/Panalog_Explained.pdf
13. Panavision. Panalog to Linear Light Conversion. 2007
<http://www.panavision.com/sites/default/files/docs/documentLibrary/Panalog%20Linear.pdf>
14. Harald Brendel, 2 August 2012. ALEXA LogC Curve – Usage in VFX
http://www.arri.com/camera/digital_cameras/downloads/1.023.
15. Larry Thorpe. 2012. Canon-Log Transfer Characteristic. Canon White Paper: EOS C300/EOS C500.
http://downloads.canon.com/CDLC/Canon-Log_Transfer_Characteristic_6-20-2012.pdf
16. N. Firee Thiele. 1994. An Improved Law of Contrast Gradient for High Definition Television. doi: 10.5594/J09715. SMPTE Mot. Imag J. January 1, 1994 vol. 103 no. 1 18-25
17. Scott Miller, Mahdi Nezamabadi and Scott Daly. Perceptual Signal Coding for More Efficient Usage of Bit Codes. SMPTE Motion Imaging Journal. 2013. 122:52-59. doi: 10.5594/j18290
18. P.G.J. Barten, Formula for the Contrast Sensitivity of the Human Eye, Proc. SPIE-IS&T, 5294:231–238, Jan. 2004.
19. Ibrahim Sezan, M., Kwok-Leung Yip, and Scott J. Daly. "Uniform perceptual quantization: Applications to digital radiography." Systems, Man and Cybernetics, IEEE Transactions on 17, no. 4 (1987): 622-634.
20. David Touz , Yannick Olivier, Sebastien Lasserre, Fabrice Lel annec, Ronan Boitard, Edouard Fran ois. HDR Video Coding based on Local SDR Quantization. HDRi2014 - Second International Conference and SME Workshop on HDR imaging. March 05, 2014.
21. Poynton, C. and Funt, B. (2014), Perceptual uniformity in digital image representation and display. Color Res. Appl., 39: 6–15. doi: 10.1002/col.21768

22. Poynton, C. Perceptual uniformity in Digital Imaging,” Proc. Gjøvik Color Imaging Symposium (GCIS 2009): 102–109. A lightly edited version of which is available online in www.poynton.com/notes/PU-PR-IS/Poynton-PU-PR-IS.pdf