



SPEC SHEET

Evergreen Premium



Evergreen Premium

THE HIGHEST QUALITY PANEL ON THE MARKET

An architecturally designed system with commercial grade materials makes the Evergreen Panel the ultimate in artificial green walls. The fire-rated foliage is installed to look like it's growing across the wall and is alive with elegant vibrancy. Relatively lightweight and easy to specify into any project - it's a dream for building designers and clients alike.

OUR STYLES



Evergreen Premium

BENEFITS & SPECIFICATIONS



FIRE-RESISTANT

Australia's only group 2 fire rated panel.



UV STABLE

Our panels are made with a UV stabilised polyethelene. There is no need to replace or add UV lighting like you do on real walls, our artificial garden walls will last forever.



MAINTENANCE FREE

Once installed, there is no need for additional power for lights, irrigation systems or call out fees to maintenance. The only upkeep you need to do is clean your plants with a damp cloth, or let the rain clean it for you. Simple.



WARRANTY

For peace of mind, we offer a 4-year warranty on selected products. This covers UV damage, fading or cracking.

INSTALLATION GUIDELINES:

evergreenwalls.com.au/installation-guide

Evergreen Premium

PACKAGING & COMPONENTS

All Evergreen Premium Walls are delivered neatly packaged with everything needed for a typical installation.

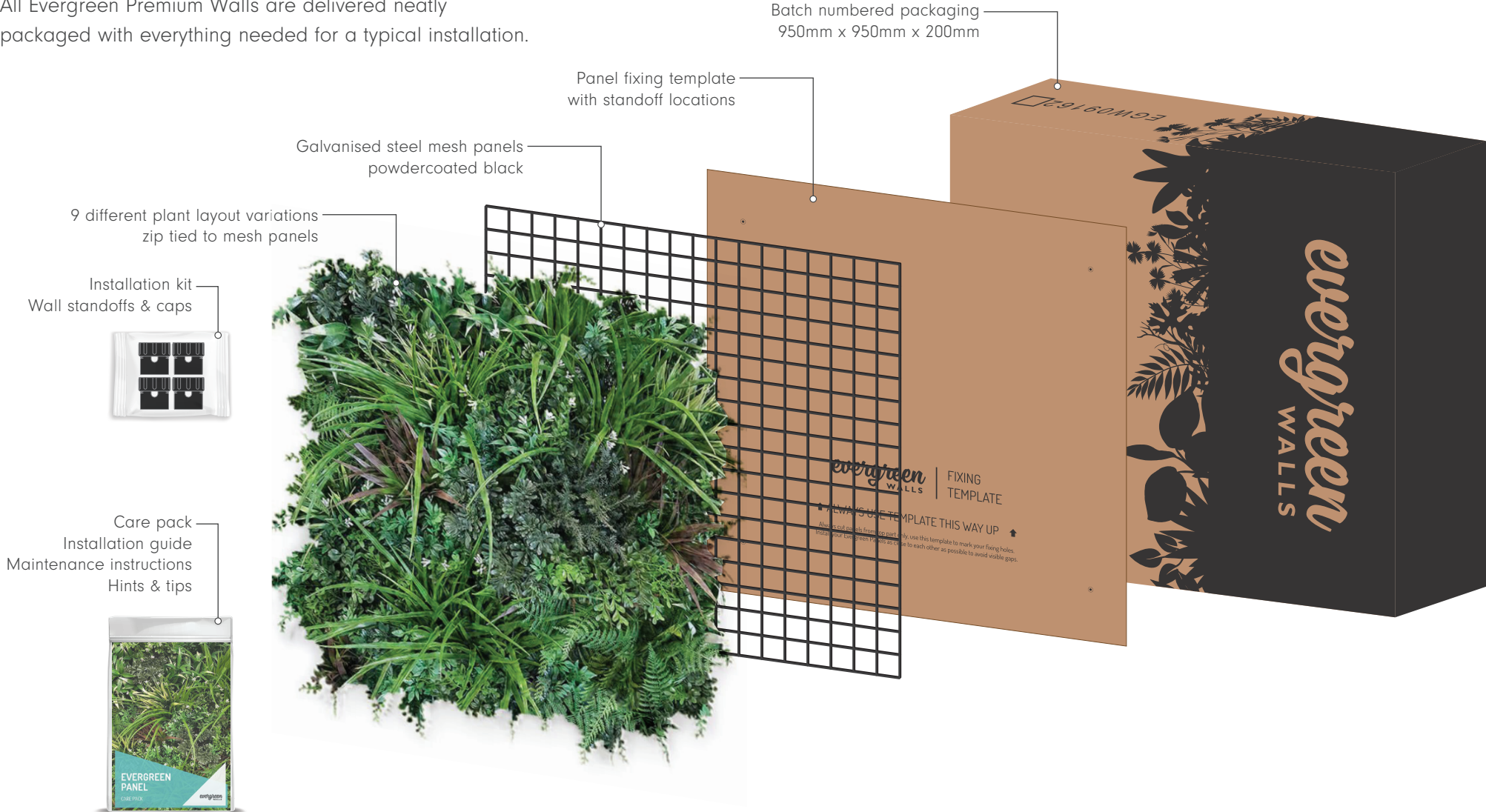

Evergreen Premium

INSTALLATION KIT

The supplied proprietary stand-off fixings are designed to hold the mesh panels to most wall types.

Each Typical Installation Kit includes:

4 x Standoffs

4 x Standoff caps

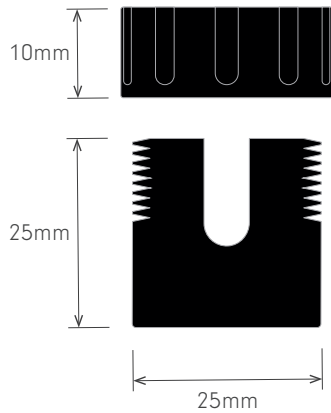

STANDOFF LOCATIONS

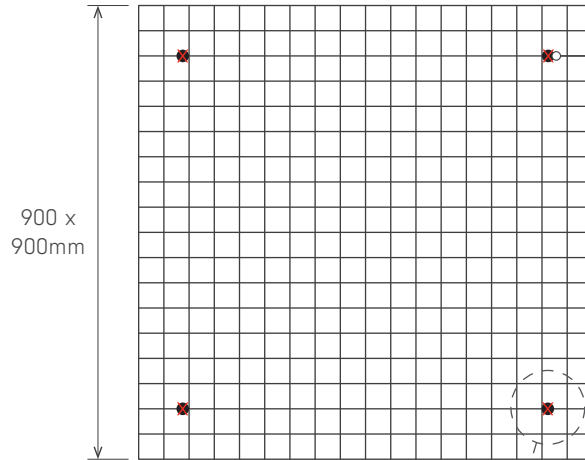

Use the supplied fixing template to locate the 4 x standoffs on the wall to align with the horizontal part of the grid.

FIXING DETAILS

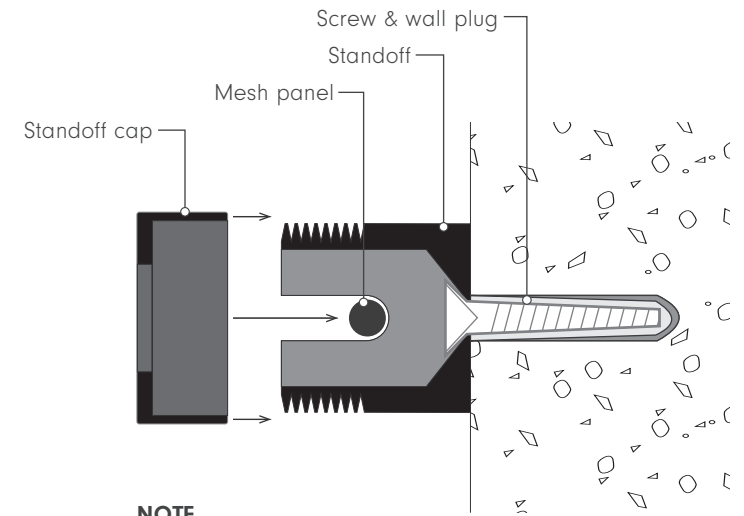
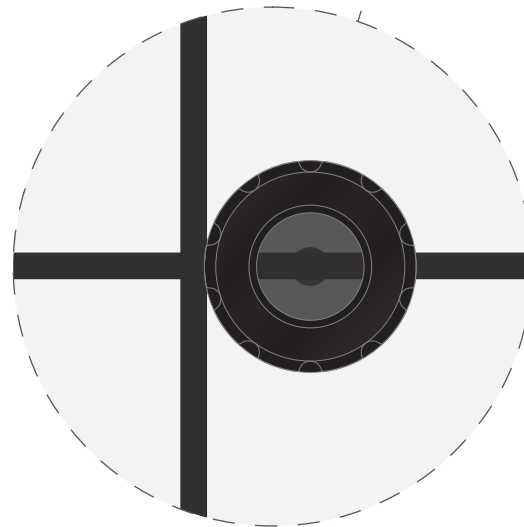

NOTE

Wall fixings shall suit site specific wall types. It is recommended this is checked prior to installation.

Evergreen Premium

9 PLANT PANEL VARIATIONS

To avoid unwanted patterns occurring when the panels are linked together, the layout of the panels are to be divided in to 9 different layouts.

Each layout must be slightly different to the next using different amount of plants for each panel. Plant layouts to be confirmed with supplier.

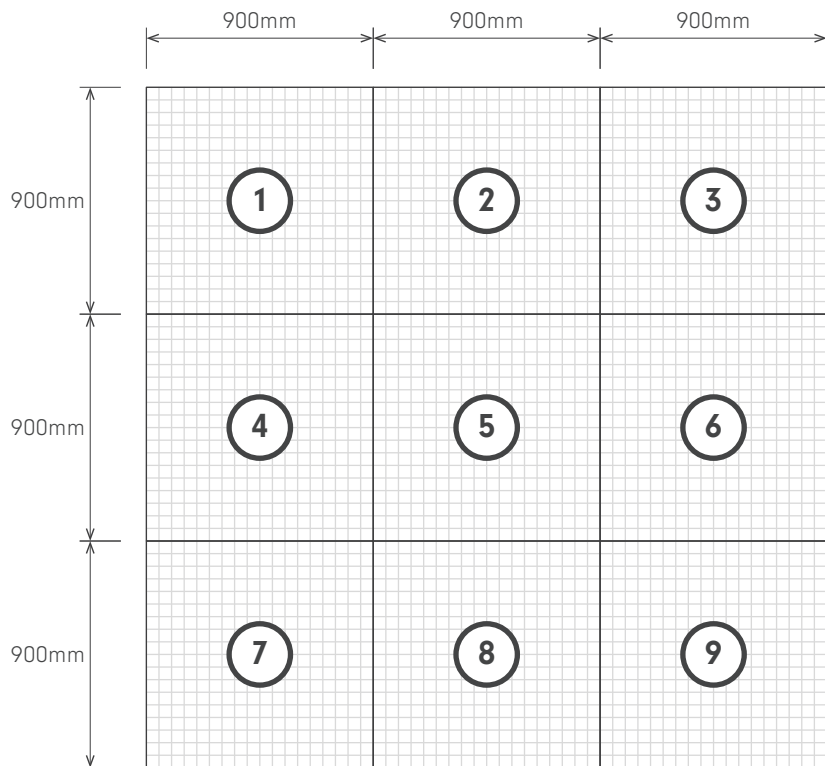

NOTE

Panel layouts and combinations should be designed to suit wall sizes prior to installation.

PANEL FIXING

All plants are fixed to panels using **3 black cable ties per plant for securely fixing to the mesh grid.**

Each plant is tied neatly through the mesh grid and affixed from behind. Plants are fixed facing upwards with overhang on top, a small amount on the sides and a minimal amount of overhang at the bottom.

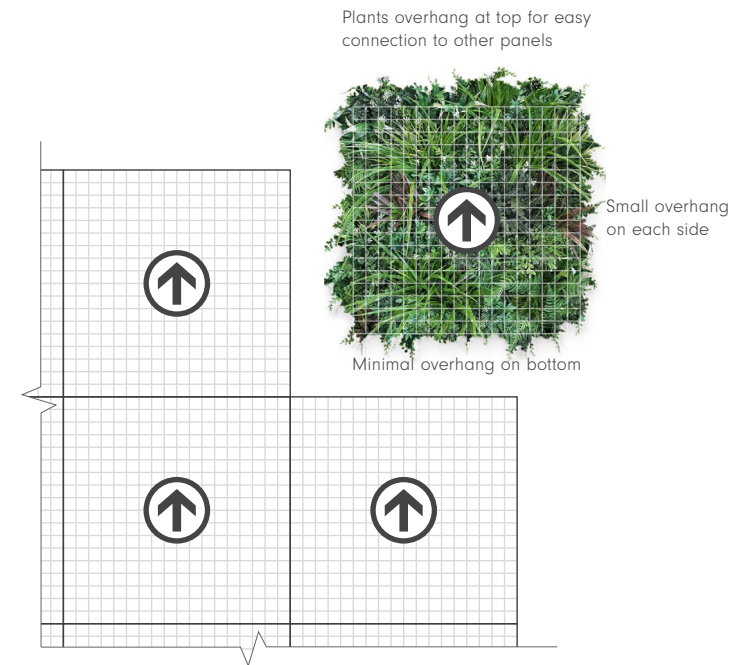

NOTE

Plants to always face in an upwards direction.

Talk With Us

PHONE

+61 2 8197 3002

EMAIL

info@evergreenwalls.com.au

ADDRESS

50/117 Old Pittwater Rd
Brookvale NSW 2100
AUSTRALIA

WEBSITE

evergreenwalls.com.au
evergreenplants.com.au

SOCIAL

 @evergreen_walls

 @evergreenwalls

 @evergreenwalls

 @evergreenwalls

