



INSTALLATION INSTRUCTION



GENOTEK

D-1500 AND DK-1500 WALL AND CEILING EXPANSION JOINT COVER

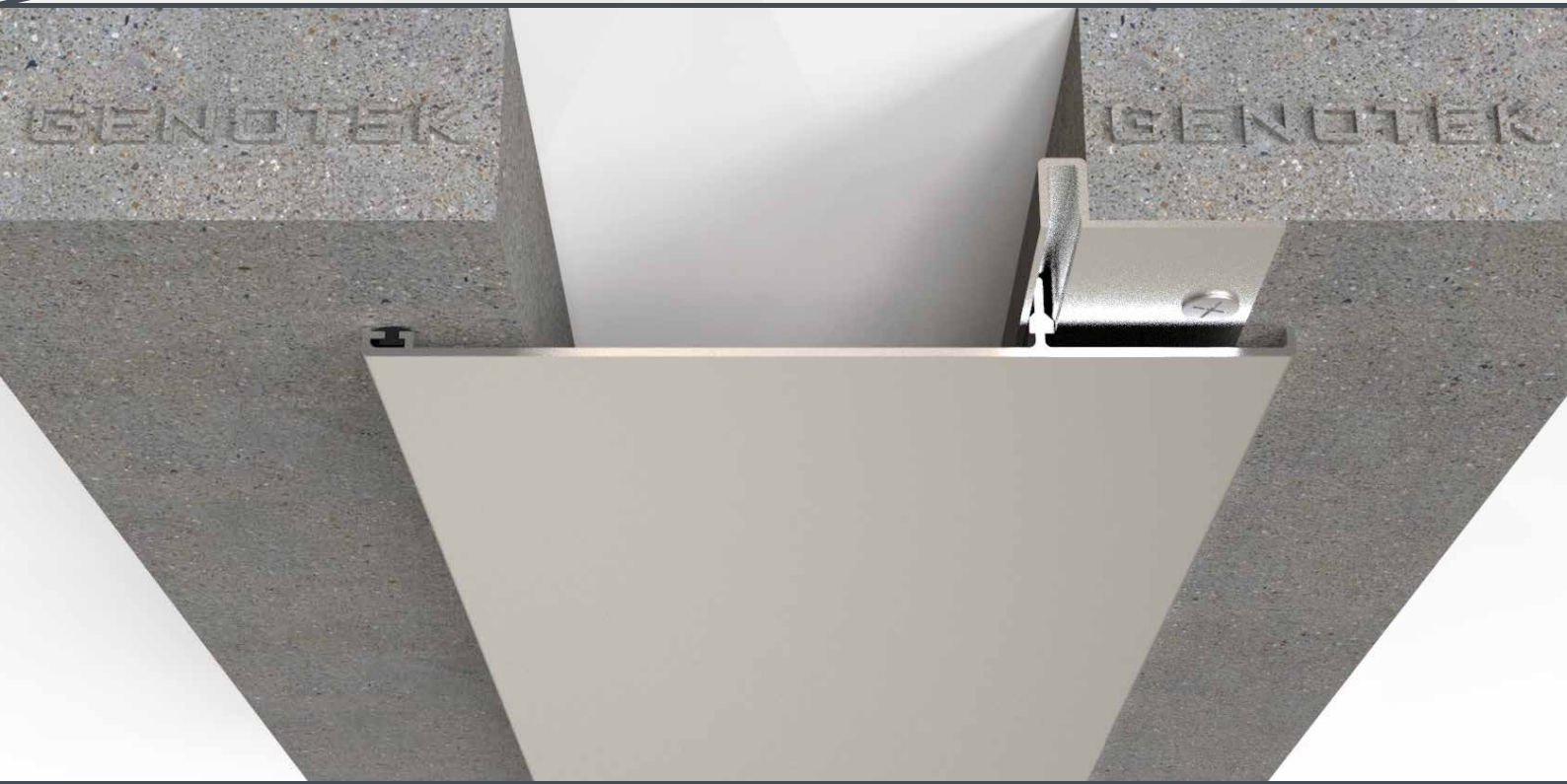

The following installation instructions are very important. Read them carefully, and be sure you understand them completely before you begin any work.

STORAGE & HANDLING

The expansion joint covers are shipped UNASSEMBLED .Upon receipt, this product should be stored in the horizontal position in a clean, dry location. This is a finished product. Store this product in a protected area.

D-1500 SERIES, FLOOR COVERS PARTS LISTS

ITEM	DESCRIPTION	PART NUMBER
1	BASE MEMBER	SA8371
2	COVER PLATE	SA8172



D-1500 AND DK-1500 WALL & CEILING EXPANSION JOINT COVER

INSTALLATION FOR 30MM JOINT WIDTH

These installation instructions are for use in the installation of D-1500 Series Expansion Joint Covers. After the concrete, masonry, or steel stud and gypsum wallboard substrate, wall and ceiling (see figure 1), are in place, the D-1500 series expansion joint covers may be installed. The joint cover system shall be installed as follows;

STEP 1. Review GENOTEK approved shop drawings for types and locations.



Figure 1.

STEP 2. Attach the clip (SA8371) to the wall or ceiling using the anchors with spacing the anchors a maximum of 30 cm. o.c. The anchor at the ends of the extrusion must be a maximum of 15cm. from the end of the extrusion. (figure 2).

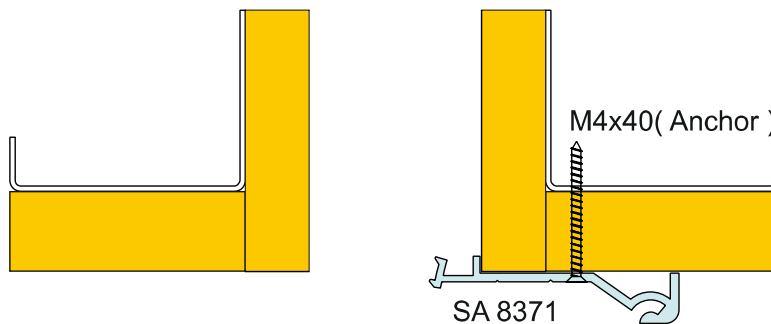

Figure 2.

STEP 3. Select a section of cover plate SA 8372 (See Figure 3).



Figure 3.



INSTALLATION INSTRUCTION



GENOTEK

D-1500 AND DK-1500 WALL & CEILING EXPANSION JOINT COVER

STEP 4. Place the selected cover plate in position over the installed base member clips. Ensure that the center plate is properly centered over the joint and that it is properly aligned with the base member clips. Ensure that the installation is plumb and level.

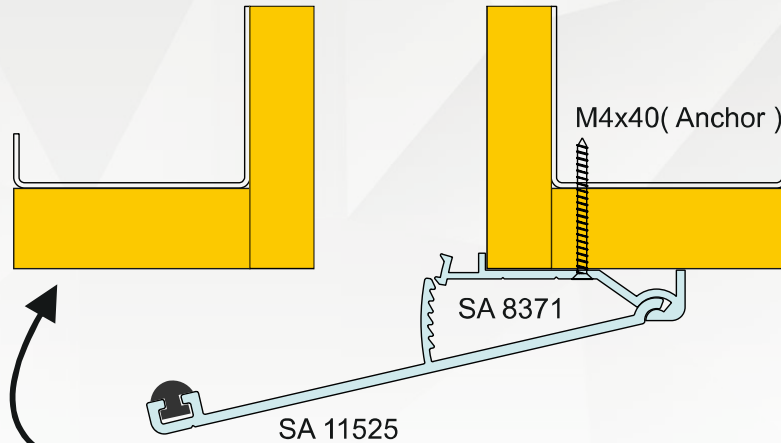

Figure 4.

STEP 5. Applying moderate pressure with your hand, partially engage the cover plate onto the base member clips. This is accomplished by pressure the cover plate's toothed tab onto the base member's locking flange.

NOTE: ENSURE THAT THE COVER PLATE IS IN EXACT POSITION BEFORE STARTING ENGAGEMENT. IT IS IMPOSSIBLE TO SEPARATE THE COVER PLATE FROM THE BASE MEMBER CLIPS WITHOUT DAMAGING THE PARTS ONCE THE BASE MEMBER CLIPS AND THE COVER PLATE ARE ENGAGED

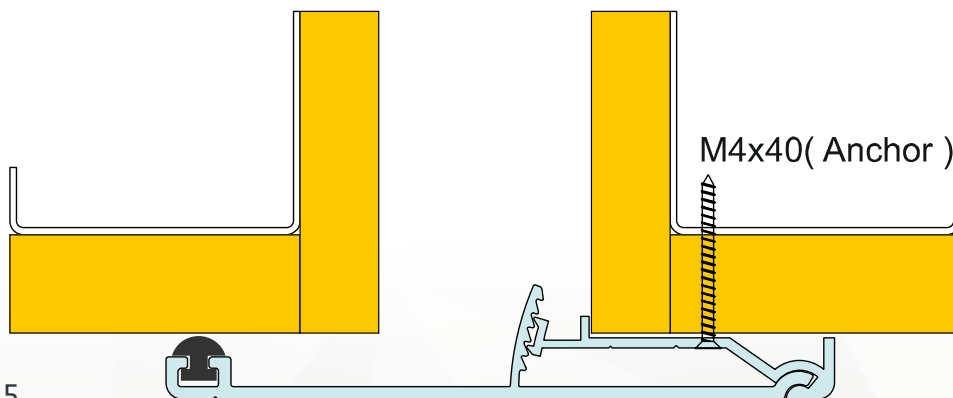

Figure 5.

STEP 6. Starting at one end of the assembly, tab the cover plate onto the base member clips tabs until the parts are fully engaged (see figure 5 above). The cover plate will snap on to the base member clips. Use a wooden block and mallet to avoid marring teh assembly.



INSTALLATION INSTRUCTION



GENOTEK

D-1500 AND DK-1500 WALL & CEILING EXPANSION JOINT COVER

Repeat all steps for installation of corner type called DK-1500.

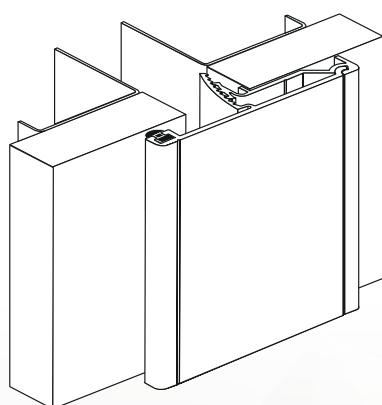
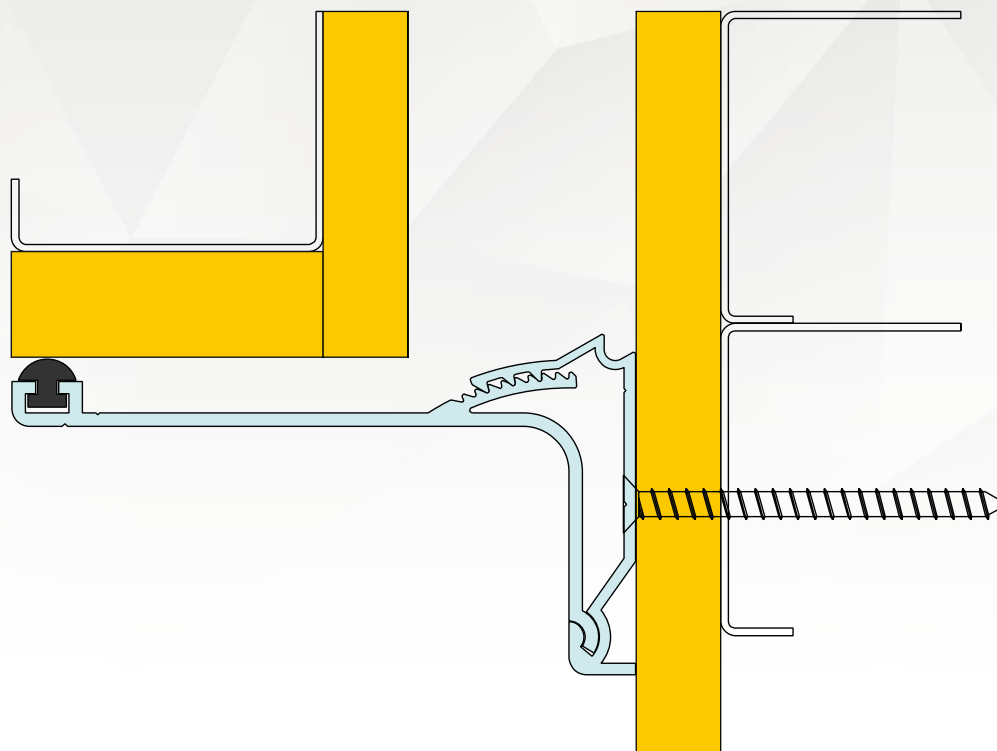

D-1500-30
(Wall to Wall)
(Ceiling to Ceiling)

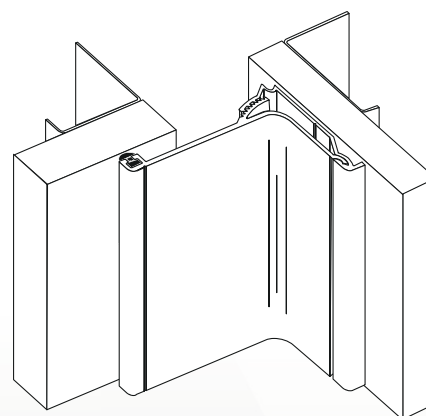

DK-1500-30
(Wall to Corner)
(Ceiling to Wall)



D-1500 AND DK-1500 WALL & CEILING EXPANSION JOINT COVER

INSTALLATION OF D-1500 FOR JOINT WIDTH >30MM

STEP 1. Cut the base member (extruded retainer) and cover plate to the desired length.



Figure 1.

STEP 2. Attach the Extruded retainer to the wall or ceiling using the anchors with spacing the anchors a maximum of 50 cm. o.c. The anchor at the ends of the extrusion must be a maximum of 25cm. from the end of the extrusion. (figure 2)

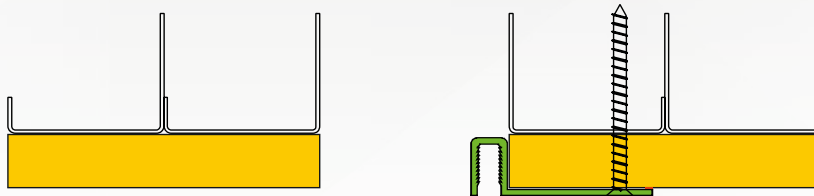

Figure 2.

STEP 3. Select a section of cover plate and Slide the flexible vinyl gaskets into the aluminum covers. Press the Tinnerman U-Clips onto the leg of the cover plate spaced approximately 50 cm on center starting 10 cm from each end (See Figure 3).

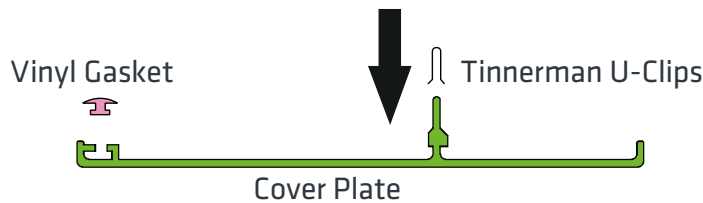
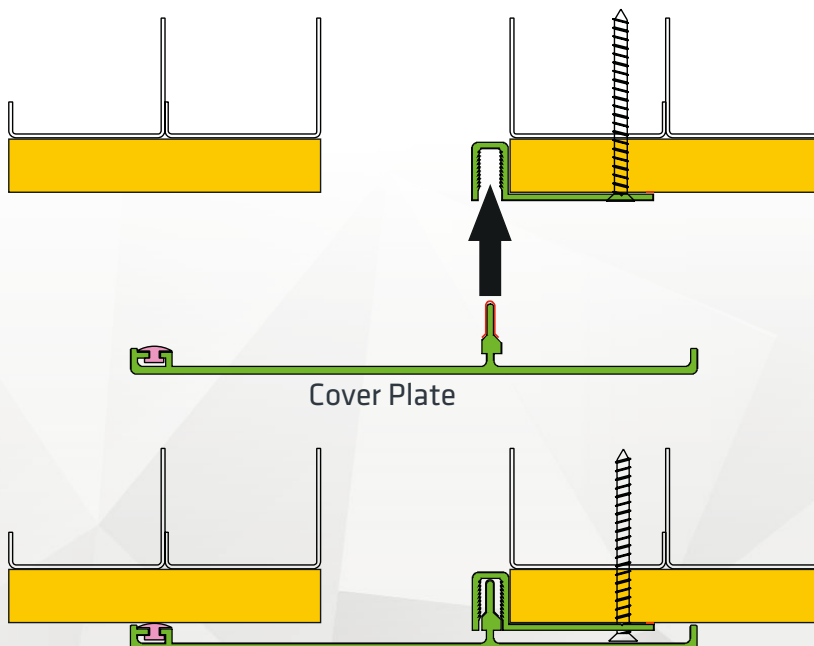

Figure 3.

STEP 4. Firmly Press the cover plate leg into the channel of base member.



D-1500 (Joint Width >30mm)
(Wall to Wall)
(Ceiling to Ceiling)



D-1500 AND DK-1500 WALL & CEILING EXPANSION JOINT COVER

INSTALLATION OF DK-1500 FOR JOINT WIDTH >30MM

STEP 1. Cut the base member (extruded retainer) and cover plate to the desired length.

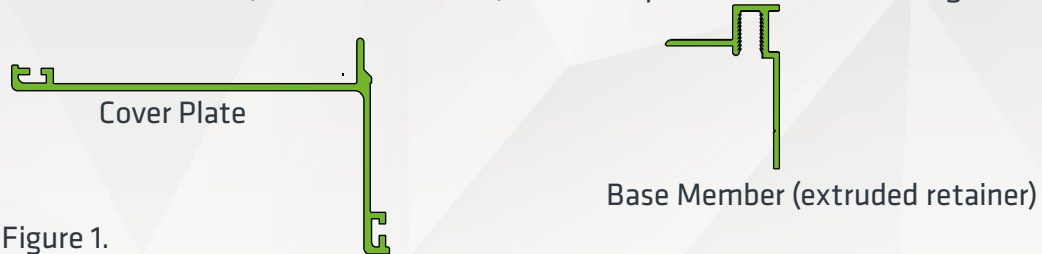

Figure 1.

STEP 2. Attach the Extruded retainer to the wall or ceiling using the anchors with spacing the anchors a maximum of 50 cm. o.c. The anchor at the ends of the extrusion must be a maximum of 25cm. from the end of the extrusion. (figure 2)

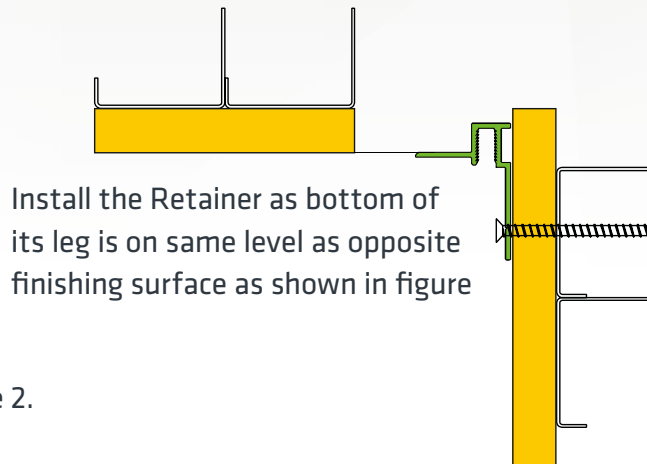

Figure 2.

STEP 3. Select a section of cover plate and Slide the flexible vinyl gaskets into the aluminum covers. Press the Tinnerman U-Clips onto the leg of the cover plate spaced approximately 50 cm on center starting 10 cm from each end (See Figure 3).

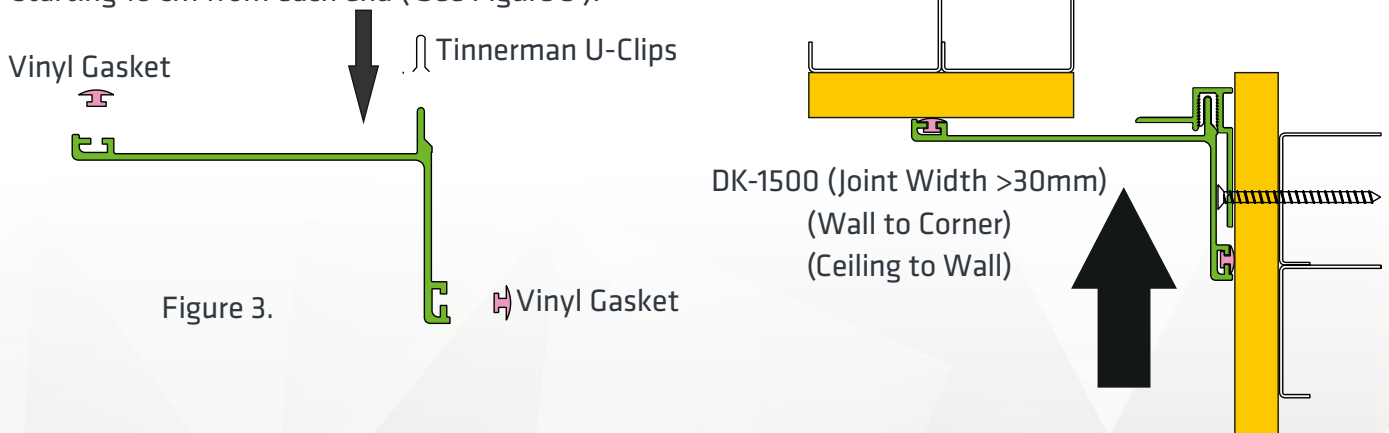

Figure 3.

STEP 4. Firmly Press the cover plate leg into the channel of base member.