



INSTALLATION INSTRUCTION



GENOTEK

D-3300 AND DK-3300 WALL AND CEILING EXPANSION JOINT COVER

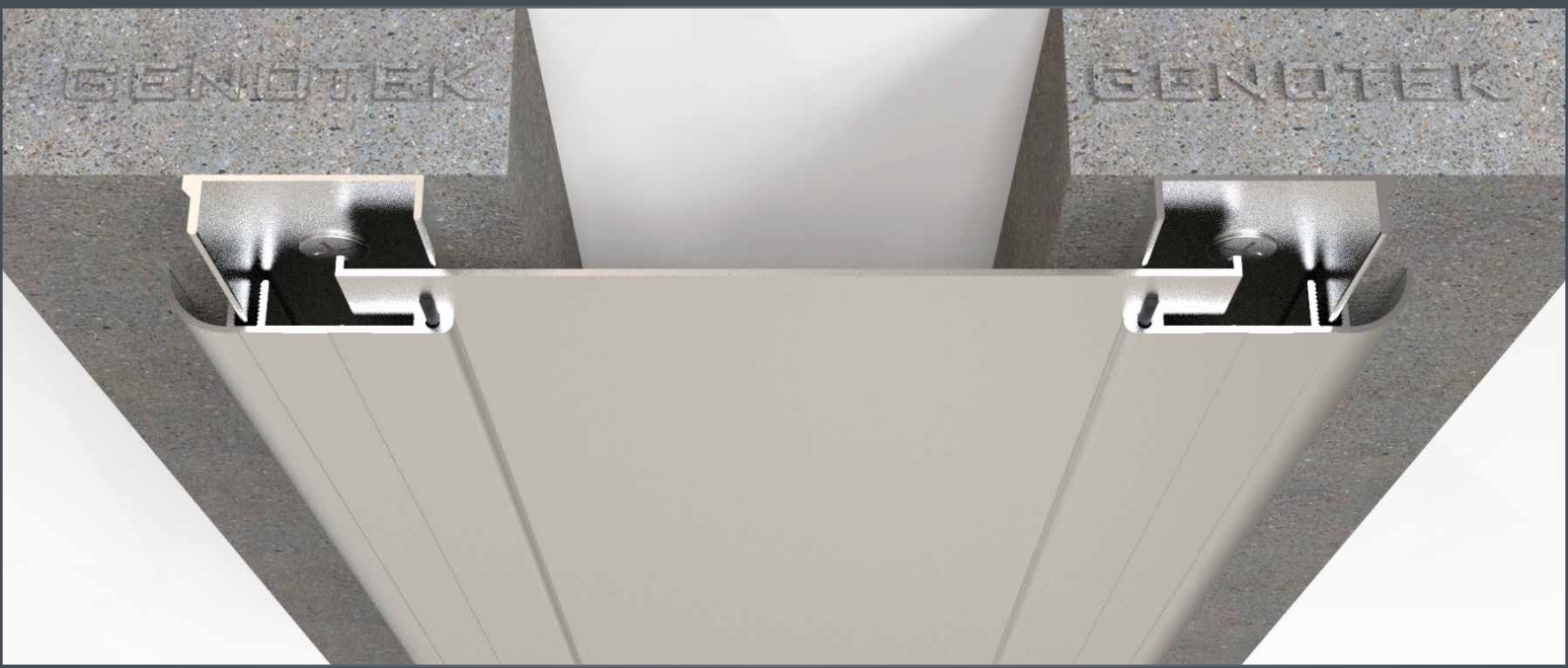

The following installation instructions are very important. Read them carefully, and be sure you understand them completely before you begin any work.

INSTALLATION OF D-3300 and DK-3300

These installation instructions are for the installation of Expansion Joint Cover Types D-3300 and DK-3300. The joint cover system shall be installed as follows:

1. Before beginning installation of the D-3300 and DK-3300, review the layouts for the various types and location as detailed on the approved GENOTEK shop drawings.
2. Select one base member extrusion, and drill the anchor holes into it, spacing the holes a maximum of 30 cm. o.c. The anchor holes at the ends of the extrusion must be a maximum of 15cm. from the end of the extrusion.
3. Drill the anchor holes in the corresponding opposite base member, using the same spacing for the holes as was used for the base member drilled in Step 2.
4. If fire barrier is provided with the system, install it at this time. See the installation instructions for the appropriate fire barrier type provided.
5. Select one of the drilled base members and place it in position against the substrate and along the edge of the joint. Refer to the details for proper positioning of the base member from the edge of the joint. Ensure that the base member is level and properly aligned.



D-3300 AND DK-3300 WALL AND CEILING EXPANSION JOINT COVER

6. Select one of the drilled base members and place it in position against the substrate and along the edge of the joint. Refer to the details for proper positioning of the base member from the edge of the joint. Ensure that the base member is level and properly aligned.
7. For concrete or masonry substrates, remove the base member and drill the anchor holes into the substrate at the locations marked in Step 5.
8. Put the base member back into position on the concrete or masonry substrate, aligning the anchor holes in the base member with the anchor holes in the substrate, and attach the base member to the substrate using the fasteners (Not supplied by GENOTEK). (See figure 1.)

(NOTE: IF REQUESTED AT THE TIME OF APPROVAL, APPROPRIATE CONCRETE ANCHORS WILL BE PROVIDED FOR CONCRETE AND MASONRY INSTALLATIONS.)

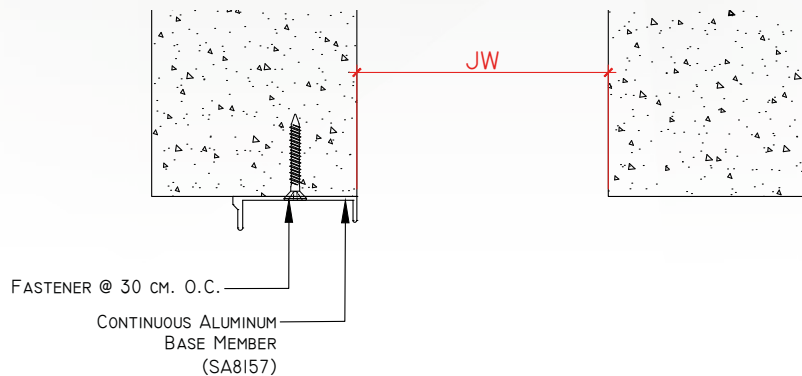

Figure 1.

9. If the substrate is stud and wallboard, use the self-tapping, self-drilling fasteners to attach the base member to the substrate. Ensure that the fasteners are attached to the studs in the wall or ceiling.
10. If the tinnerman clips were not installed on the base member's tab at the factory, install the TC's at this time (see Figure 2). The TC's are spaced at 50 cm. O.C.

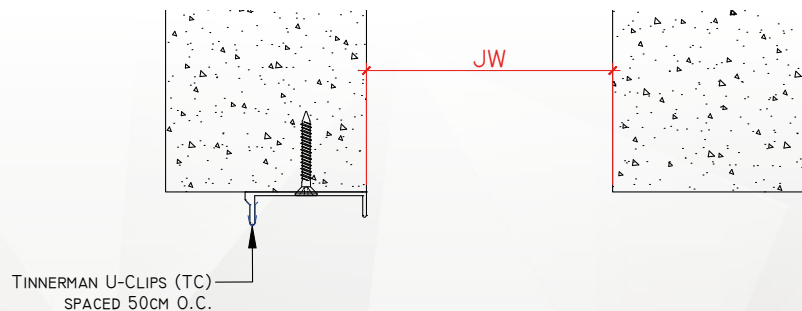

Figure 2.



D-3300 AND DK-3300 WALL AND CEILING EXPANSION JOINT COVER

11. Place the corresponding opposite base member in position on the substrate along the other edge of the joint. Refer to the details for proper positioning of the base member from the edge of the joint. Ensure that the base member is level and properly aligned. Attach the base member to the substrate using the applicable procedures in Step 4 through Step 8 (see Figure 3).



Figure 3.

12. The cover plate (part no. SA8158) is provided with a protective tape coating. This coating is primarily designed to protect the finish of the cover plate, but it also provides a surface for marking the cover plate. Place the cover plate in position over the base member and mark the position of the tinnerman clips on the surface of the protective tape coating. Do not engage the base member's tab into the cover plate's channel at this time. Marking the cover plate in this manner will aid in installation by indicating where pressure needs to be applied to the cover plate for full engagement of the clips into the cover plate's channel.
13. If the gasket was installed at the factory, proceed to Step 15. If the gasket is not already installed, cut a section of the gasket to fit continuously into the cover plate and proceed to Step 14. The gasket section must be at least as long as the cover plate.
14. Slide the section of gasket cut in Step 9 into the channel in the cover plate. Trim any excess gasket away from the assembly.
15. Select the center plate, remove any protective tape from its exposed surface, and place it in position over the installed base members (see Figure 4). Ensure that the center plate is properly centered over the joint. Ensure that the installation is plumb, level, and properly aligned.

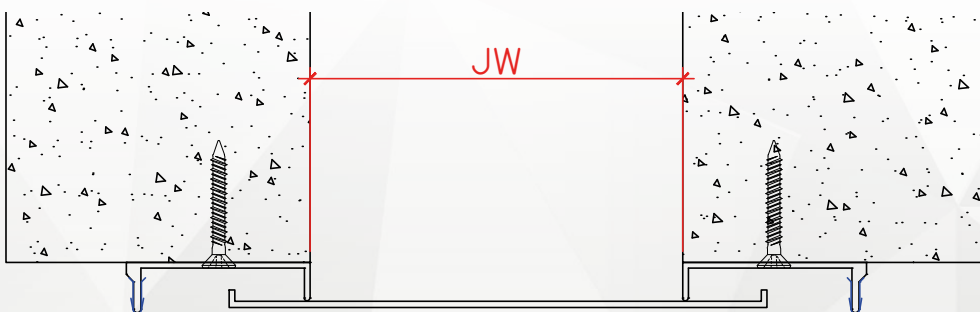

Figure 4.



D-3300 AND DK-3300 WALL AND CEILING EXPANSION JOINT COVER

16. Ensuring that the center plate remains properly aligned and centered, place one of the cover plates in position over the installed base member and the center plate (see Figure 5). The cover plate's channel will align with the base member's tab and the gasket will rest over the center plate.

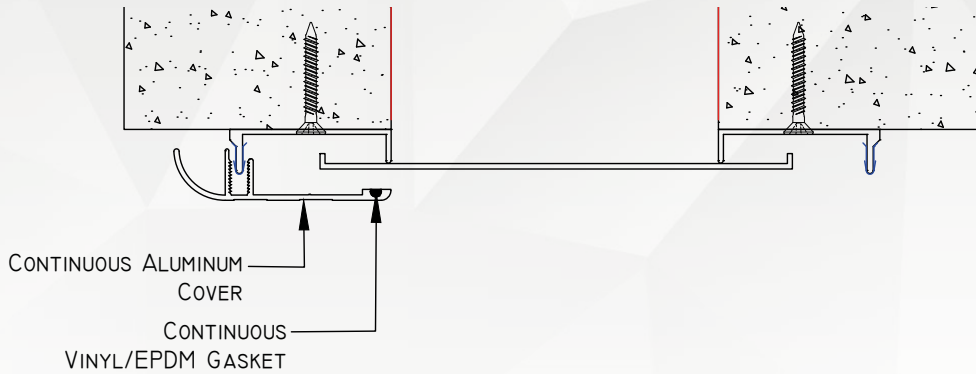

Figure 5.

(NOTE: ENSURE THAT THE COVER PLATES ARE IN EXACT POSITION BEFORE STARTING ENGAGEMENT. SEPARATING THE COVER PLATE FROM THE BASE MEMBER WITHOUT DAMAGE IS VERY DIFFICULT ONCE THE CLIPS, THE BASE MEMBERS, AND THE COVER PLATES ARE ENGAGED.)

17. Applying moderate pressure with your hand, partially engage the cover plate onto the base member on one side. This is accomplished by pressing the cover plate's channel partially onto the base member's tab, and the attached timmerman clip.
18. Starting at one end of the assembly, tap the cover plate onto the base member's tab until the parts are fully engaged. Use a wooden block and a mallet to avoid marring the assembly.
19. Repeat Step 10 through Step 16 for the opposite corresponding cover plate (see Figure 6).

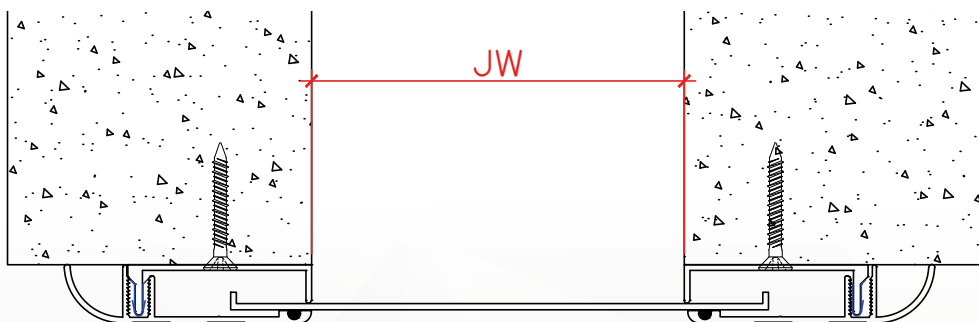

Figure 6.

20. Remove the protective tape from the exposed surface of the cover plates.