

OPTION 1: WTZ-I800

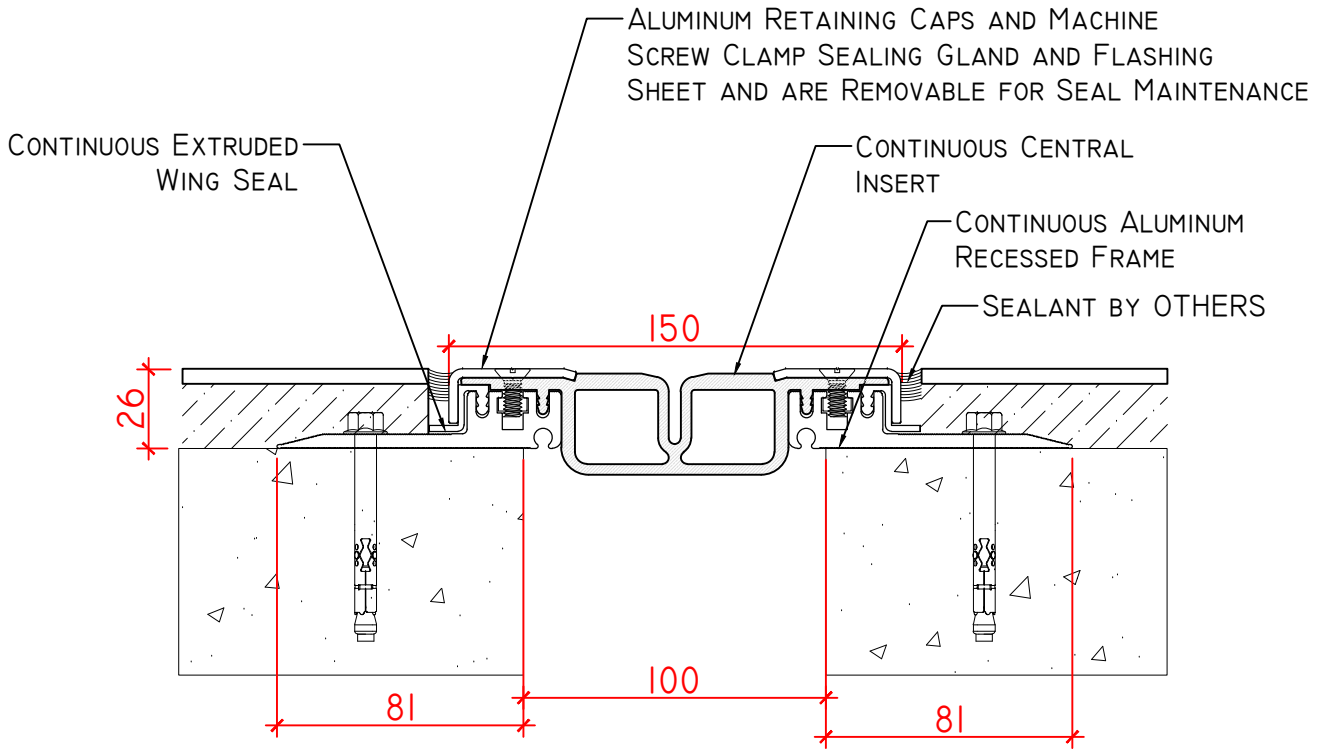

OPTION 2: WTZ-I800 w/ COVER PLATE

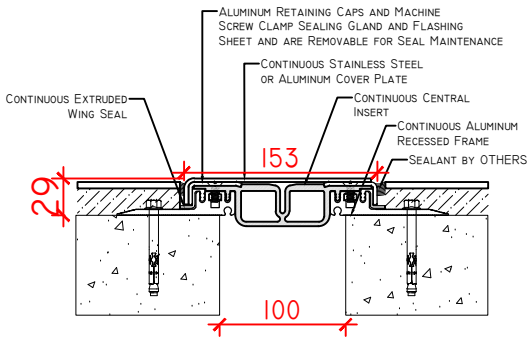

OPTION 3: WTZ-I800 + FIRE BARRIER

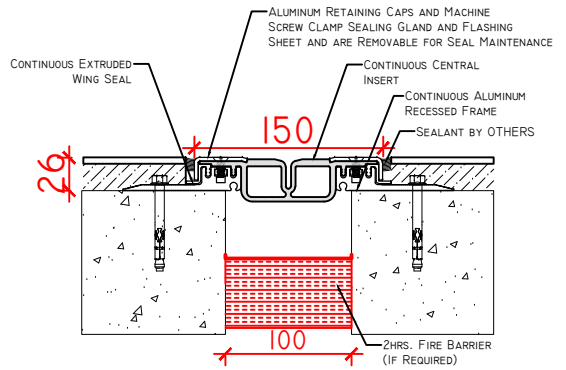

OPTION 4: WTZ-I800 + WATER BARRIER

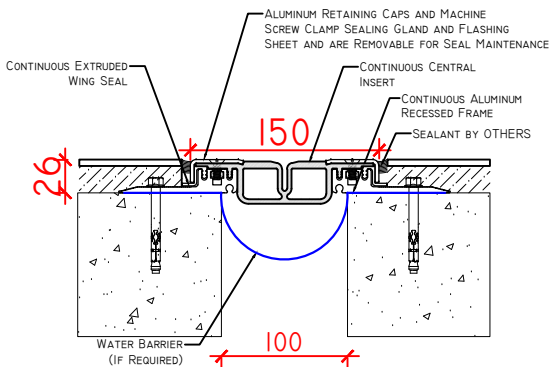

OPTION 5: WTZ-I800 + WATER BARRIER + FIRE BARRIER

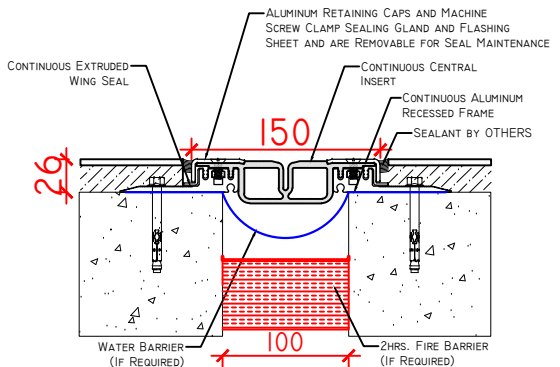

SKU	NAME	JOINT WIDTH, JW(MM)	HEIGHT, H(MM)	SIGHTLINE, S(MM)	MOVEMENT CAPACITY %	LOAD CAPACITY (KN)
WTZI800I0026I50	WTZ-I800-100	100	26	150	±40	35



PRODUCT TYPE: EXPANSION JOINT COVER

APPLICATION: FLOOR TO FLOOR WATERTIGHT CONDITION

APPROVED BY CLIENT: