

OPTION 1: WTZ-1800

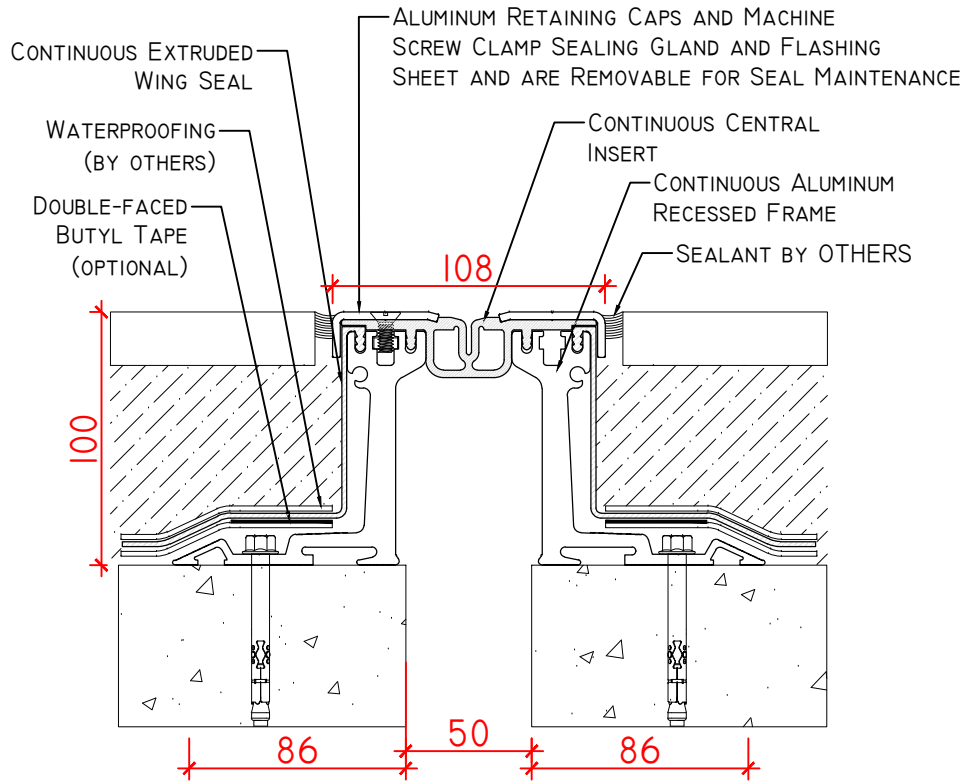

OPTION 2: WTZ-1800 w/ COVER PLATE

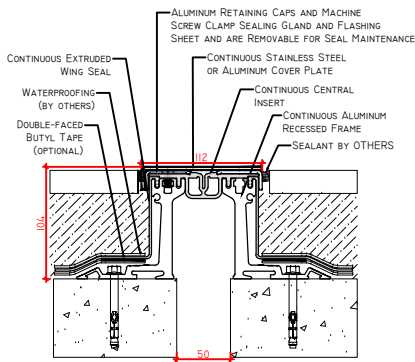

OPTION 3: WTZ-1800 + FIRE BARRIER

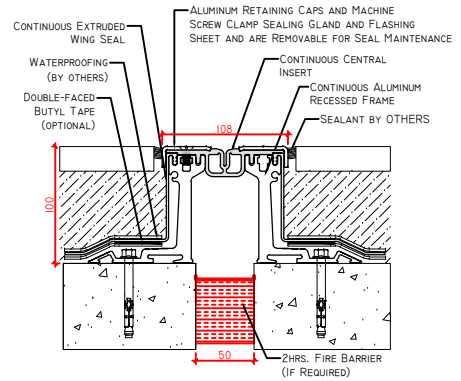

OPTION 4: WTZ-1800 + WATER BARRIER

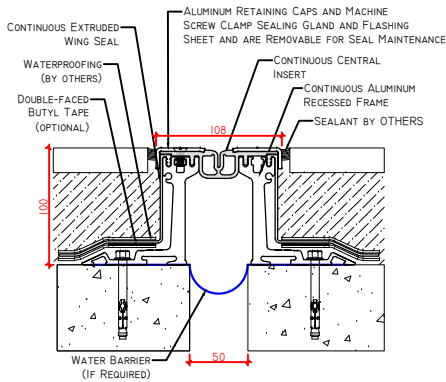

OPTION 5: WTZ-1800 + WATER BARRIER + FIRE BARRIER

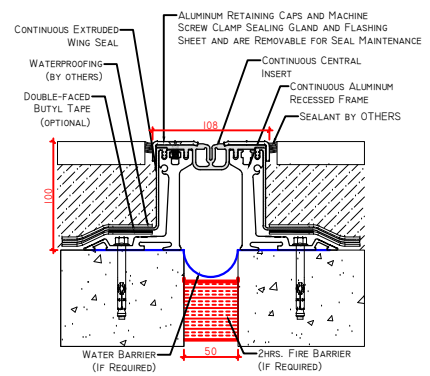

SKU	NAME	JOINT WIDTH, JW(MM)	HEIGHT, H(MM)	SIGHTLINE, S(MM)	MOVEMENT CAPACITY %	LOAD CAPACITY (KN)
WTZI80050I00I08	WTZ-1800-50	50	100	108	±40	35



**PRODUCT TYPE:** EXPANSION JOINT COVER

**APPLICATION:** FLOOR TO FLOOR WATERTIGHT CONDITION

**APPROVED BY CLIENT:**