

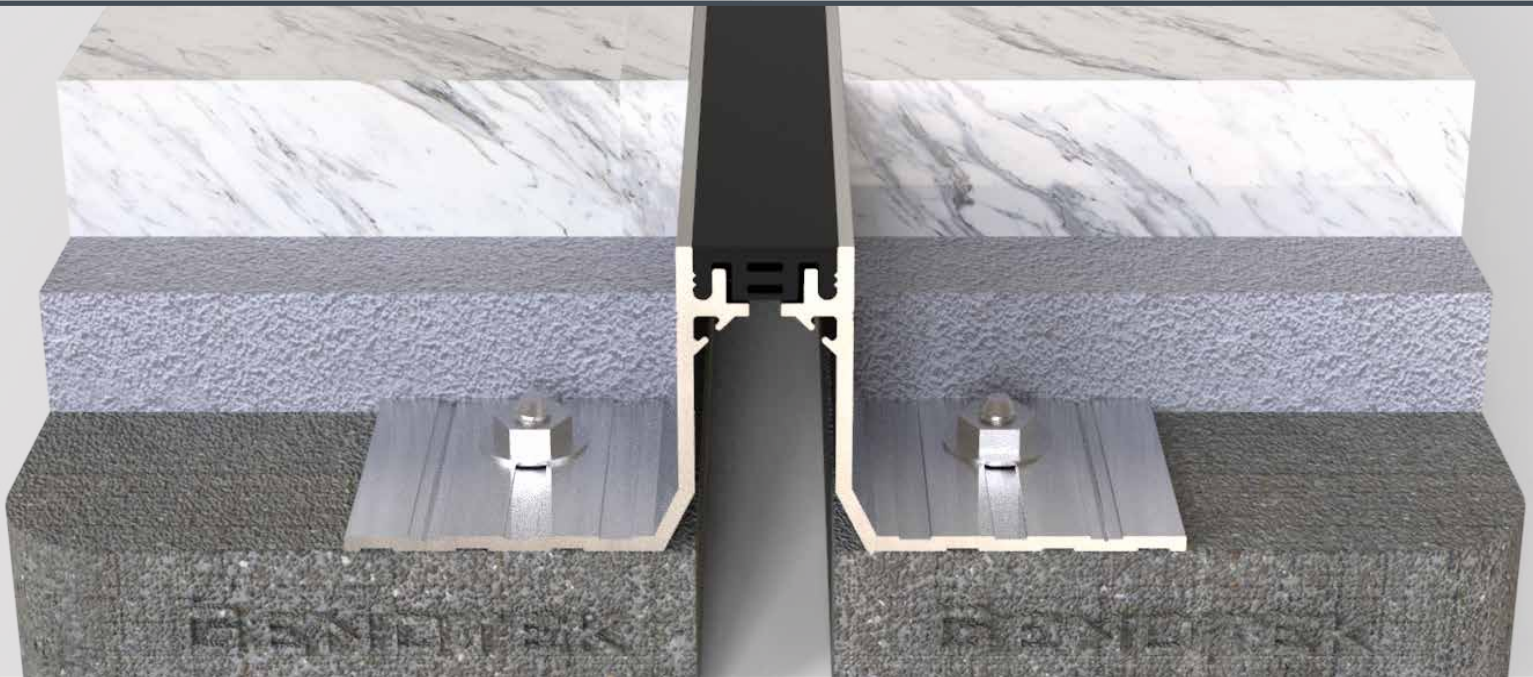

Z-1000 & ZK-1000 THERMAL RECESSED MODULAR FLOOR SYSTEMS



PRODUCT DESCRIPTION

The Z - 1000 Expansion Joint Cover is an ideal Cover for Floor to Floor applications.

The Series is suitable for areas where Thermal Movement in the adjacent slab is expected.

The components of the Z - 1000 cover are:

- Extruded Aluminium Support Profiles.
- Elastomeric Rubber Inserts which absorb the Expansion and Contraction in the Adjacent Concrete Slabs.

The Z - 1000 is an Aluminium + Rubber Expansion Joint Cover Profile.

The Elastomeric Rubber Insert of the Profile comes in four standard colours.

Options: The Aluminium Support Profiles can be modified by providing with Stainless Steel or Brass Capping or the entire Visible Surface of the Profile can be covered with a Stainless Steel Cover Plate.

This helps in maintaining the Aesthetics between the Profile and its Adjacent Finishes.

RECOMMENDED FOR

- Interior areas with small joint sizes where minimal sightline is preferred.
- Areas where Hygiene is of importance.
- Areas where Low Foot Traffic is expected.

TECHNICAL DATA

Support profiles

The Aluminium Support Profiles are extruded using one of the multiple Aluminium Alloys and Tempers.

The selection of the Aluminium grade depends on the use case of the Profile.

Aluminium grade AA 6063 is the preferred choice for most profiles.

Elastomeric Rubber Inserts

Material	Thermoplastic Elastomer or Ethylene Propylene Diene Monomer.
----------	--

Hardness	60 - 70 ShoreA (ASTM D 2240).
----------	-------------------------------

Finish	Smooth Finish.
--------	----------------

Colours	Black, Beige, Grey and White.
---------	-------------------------------



Z-1000 & ZK-1000 THERMAL RECESSED MODULAR FLOOR SYSTEMS

Optional: Vapour Barrier

Material Ethylene Propylene Diene Monomer.

Color	Black
Tensile Strength	1431 psi - ASTM D 412
Tear Resistance (lbf/in.)	204 - ASTM D 624
Puncture Resistance (lbf)	60 at 4.49" - ASTM E 154

STORAGE & HANDLING

ALUMINIUM

• Transportation

Aluminium can be damaged during transport and constitutes in the form of scratches and wear marks that can lead to subsequent interfacial corrosion. Such damage prevents satisfactory surface treatment of the profiles.

The appearance of Aluminium is affected by minor transportation damages to the surface of the material but mechanical properties of the metal, however, remain unaffected.

To prevent such damage to the material, it is important for the Aluminium profiles to be packaged in strong paper, plastic or bubble wrap during any moving and transportation to prevent individual profile surfaces from bumping against each other thus causing scratches.

• Storage

It is important to note that Aluminium gets easily affected by water and moisture.

Aluminium alloys with higher magnesium content are sensitive to water and condensation, whereas purer alloys have greater resistance to the same.

Moisture damage to Aluminium appears as white patches/ spots or dark discolouration marks and can be observed in the event if water or condensation is trapped between Aluminium profile stacked upon or lying very close to each other.

EPDM

• Storage

The storage temperature must remain below 25° C.

There should be no direct heat sources in the storage area.

The seals should not be exposed to direct sunlight.

The seals must be protected from the effects of ozone and ionizing radiation.

The seals must be stored so as to avoid their being under tensile stress.

SUBSTRATE REQUIREMENT & PREPARATION

- The surface must have enough clearance from the reinforcement to provide enough space for the anchor.
- The surface must be level to avoid gaps.
- The gap must be uniform and in a straight line.

INSTALLATION

Kindly refer to the detailed GENOTEK Installation Instructions or contact your nearest GENOTEK Technical Centre for the same.

PACKAGING

- Aluminium Support Profile: Standard Supply Length of 3.00 LM per piece.
- Elastomeric Rubber Insert: Standard Supply Length of 25.00 LM per roll.
- Moisture Barrier: Variable Length as per requirement.
- Accessories: Original Manufacturer Packaging.



Z-1000 & ZK-1000 THERMAL RECESSED MODULAR FLOOR SYSTEMS

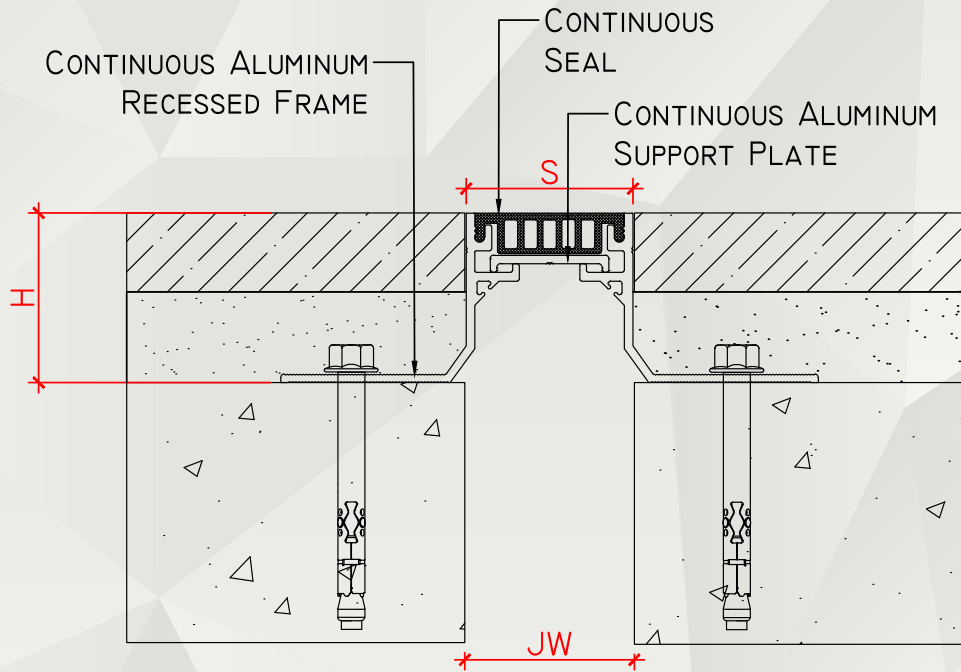

OPTIONAL: WITH COVER PLATE

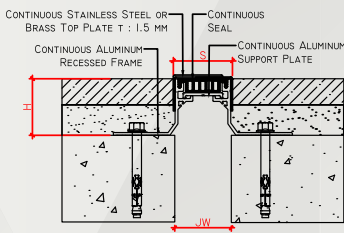

OPTIONAL: WITH WATER BARRIER

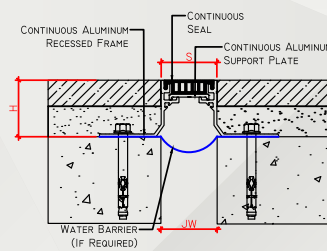

OPTIONAL: FIRE BARRIER

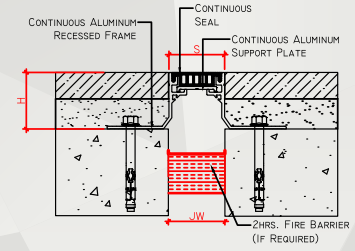

<input checked="" type="checkbox"/>	SKU	NAME	JOINT WIDTH, JW (MM)	HEIGHT, H (MM)	SIGHTLINE, S (MM)	MOVEMENT CAPACITY (%)	LOAD CAPACITY (KN)
<input type="checkbox"/>	ZI000303830	Z-1000-30	25-30	38	30	±20	25
<input type="checkbox"/>	ZI000305030	Z-1000-30	25-30	50	30	±20	25
<input type="checkbox"/>	ZI000503850	Z-1000-50	40-50	38	50	±24	20
<input type="checkbox"/>	ZI000505050	Z-1000-50	40-50	50	50	±24	20

NOTE: 1. THE ABOVE DRAWINGS ARE FOR ILLUSTRATION ONLY, PLEASE SEE THE SYSTEM DRAWING OF THE PROFILE FOR THE SECTION DETAILS AS SPECIFICATION MAY VARY.

2. THE ABOVE SIZES ARE FOR REFERENCE, ADDITIONAL SIZES MAY BE AVAILABLE AND / OR CUSTOMIZED. KINDLY CONTACT GENOTEK TECHNICAL SUPPORT FOR MORE INFORMATION.



Z-1000 & ZK-1000 THERMAL RECESSED MODULAR FLOOR SYSTEMS

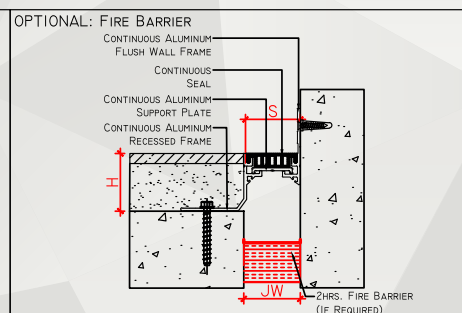
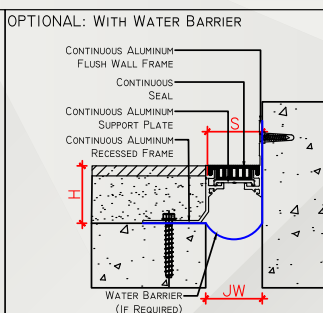
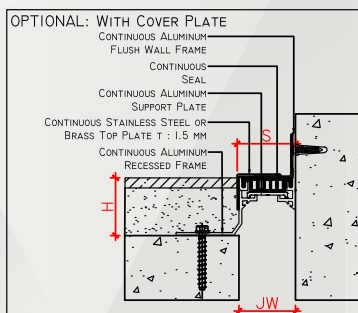
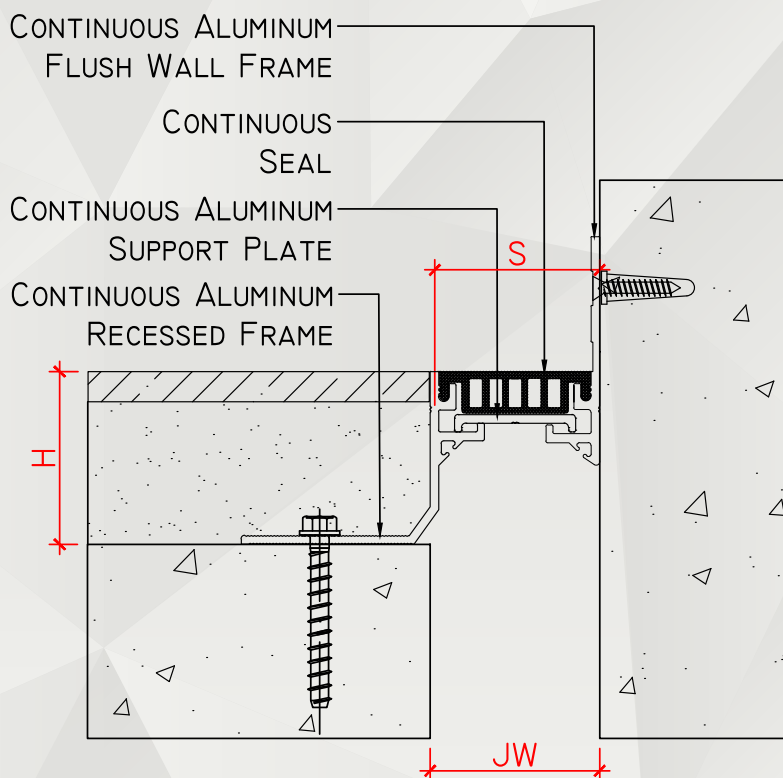

<input checked="" type="checkbox"/>	SKU	NAME	JOINT WIDTH, JW (MM)	HEIGHT, H (MM)	SIGHTLINE, S (MM)	MOVEMENT CAPACITY (%)	LOAD CAPACITY (KN)
<input type="checkbox"/>	ZKI000303830	ZK-I000-30	25-30	38	30	±20	25
<input type="checkbox"/>	ZKI000305030	ZK-I000-30	25-30	50	30	±20	25
<input type="checkbox"/>	ZKI000503850	ZK-I000-50	40-50	38	50	±24	20
<input type="checkbox"/>	ZKI000505050	ZK-I000-50	40-50	50	50	±24	20

NOTE: 1. THE ABOVE DRAWINGS ARE FOR ILLUSTRATION ONLY, PLEASE SEE THE SYSTEM DRAWING OF THE PROFILE FOR THE SECTION DETAILS AS SPECIFICATION MAY VARY.

2. THE ABOVE SIZES ARE FOR REFERENCE, ADDITIONAL SIZES MAY BE AVAILABLE AND / OR CUSTOMIZED. KINDLY CONTACT GENOTEK TECHNICAL SUPPORT FOR MORE INFORMATION.