

OPTION 1: Z-4000

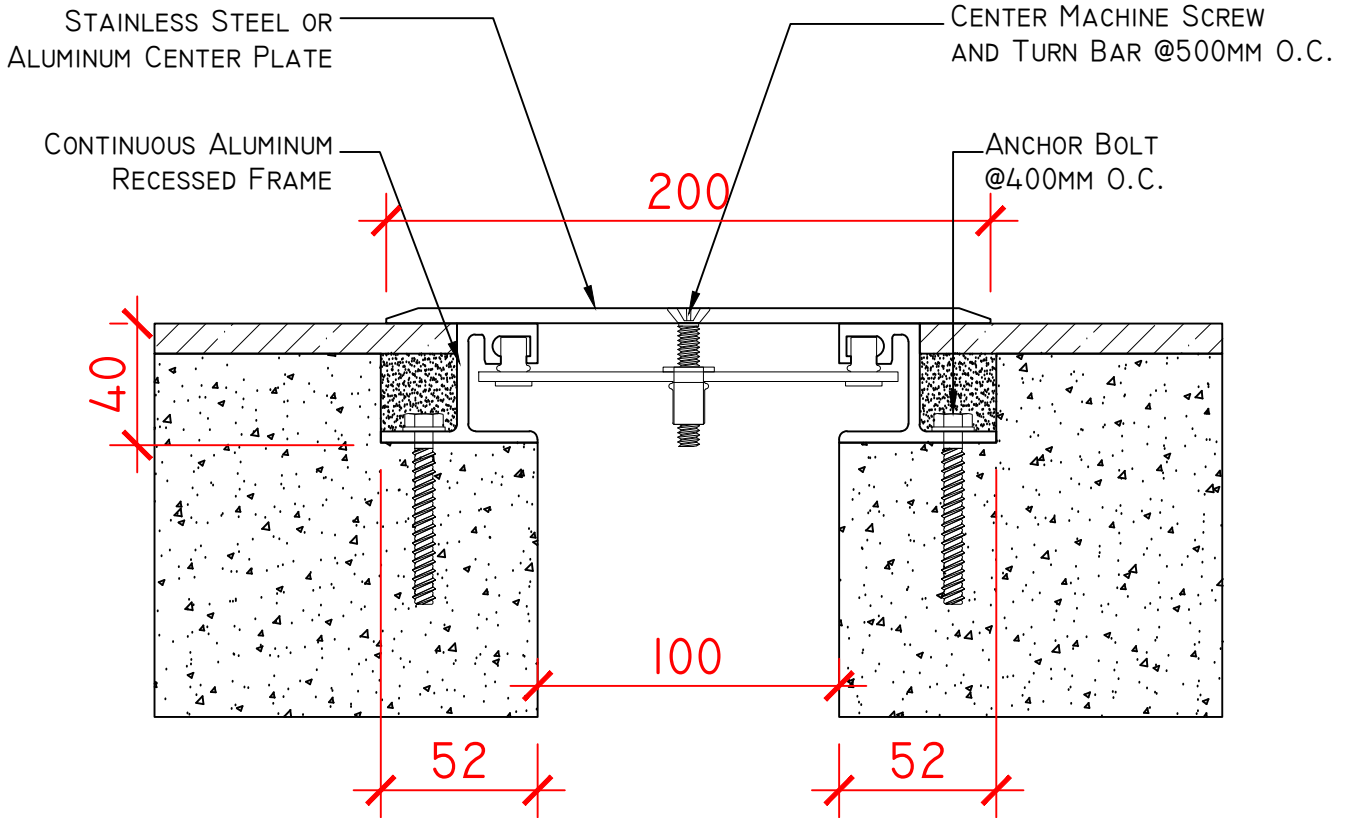

OPTION 2: Z-4000 + WATER BARRIER

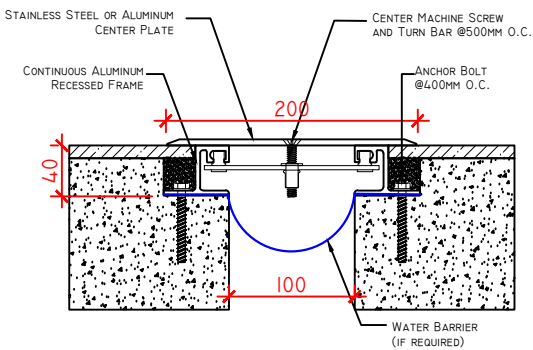

OPTION 3: Z-4000 + FIRE BARRIER

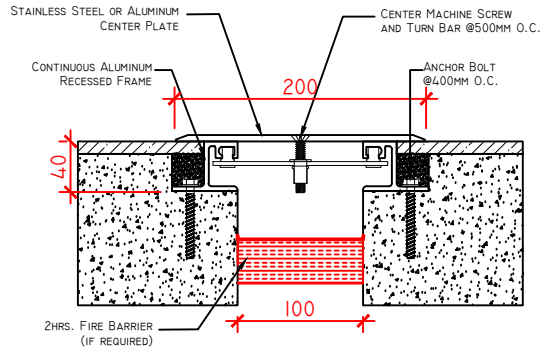

OPTION 4: Z-4000 + WATER BARRIER + FIRE BARRIER

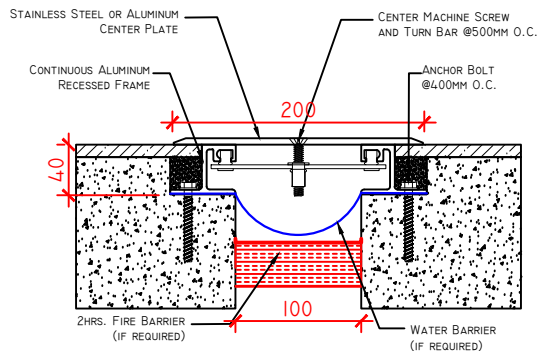

| SKU | NAME | JOINT WIDTH, JW(MM) | HEIGHT, H(MM) | SIGHTLINE, S(MM) | MOVEMENT CAPACITY % | LOAD CAPACITY (KN) |
|---------------|------------|---------------------|---------------|------------------|---------------------|--------------------|
| Z400010040200 | Z-4000-100 | 100 | 40 | 200 | ±50 | 30 |



PRODUCT TYPE: EXPANSION JOINT COVER

APPLICATION: FLOOR TO FLOOR CONDITION

APPROVED BY CLIENT: