

OPTION 1: Z-4100

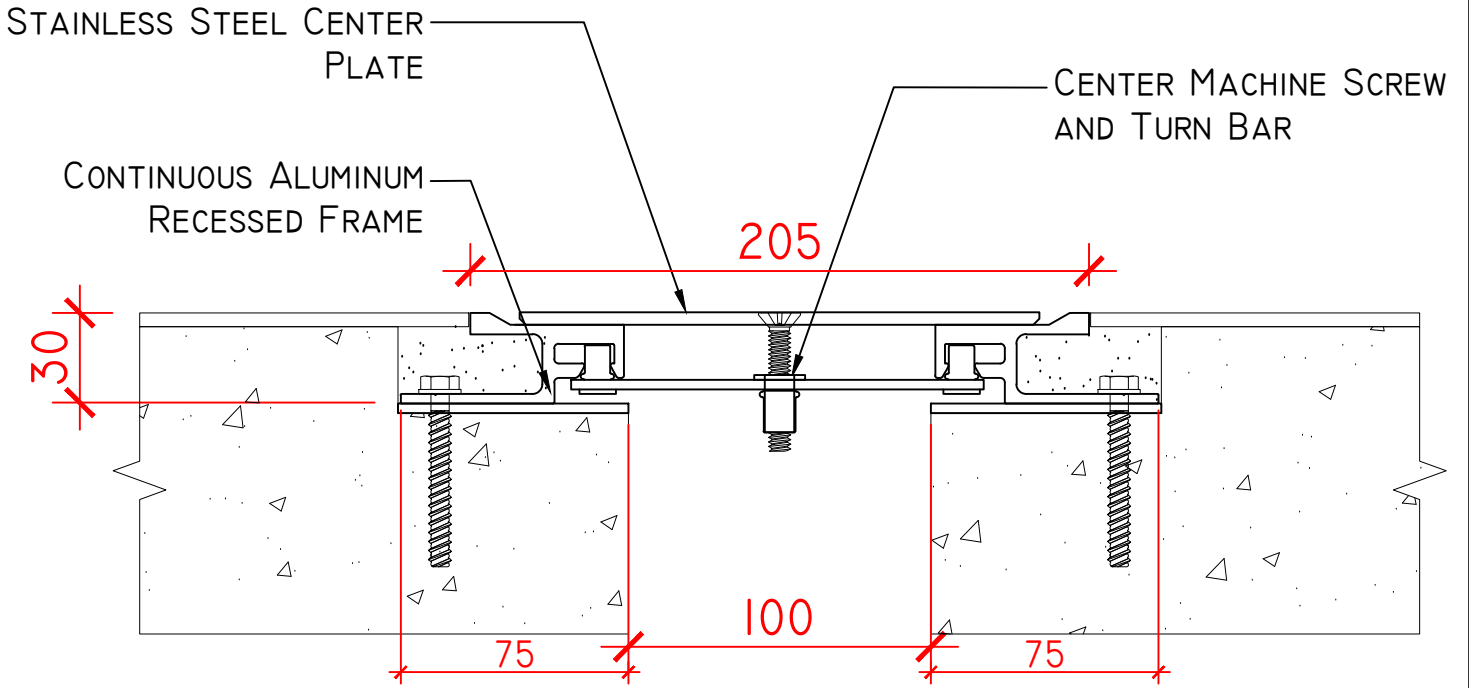

OPTION 2: Z-4100 + WATER BARRIER

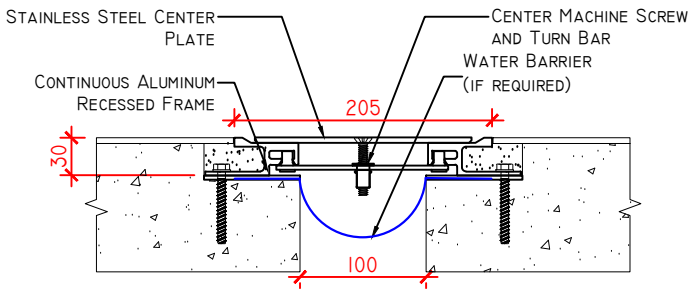

OPTION 3: Z-4100 + FIRE BARRIER

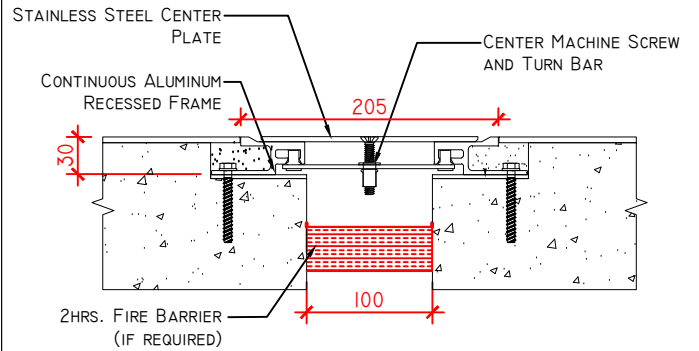

OPTION 4: Z-4100 + WATER BARRIER + FIRE BARRIER

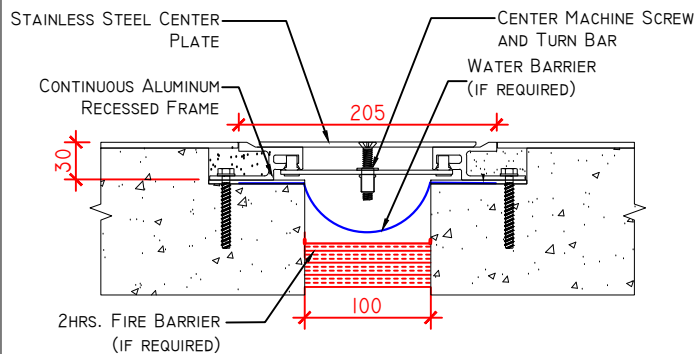

SKU	NAME	JOINT WIDTH, JW(MM)	HEIGHT, H(MM)	SIGHTLINE, S(MM)	MOVEMENT CAPACITY %	LOAD CAPACITY (KN)
Z410010030205SS	Z-4100-100SS	100	30	205	±50	35



PRODUCT TYPE: EXPANSION JOINT COVER
APPLICATION: FLOOR TO FLOOR CONDITION
APPROVED BY CLIENT: