

OPTION 1: Z-4100

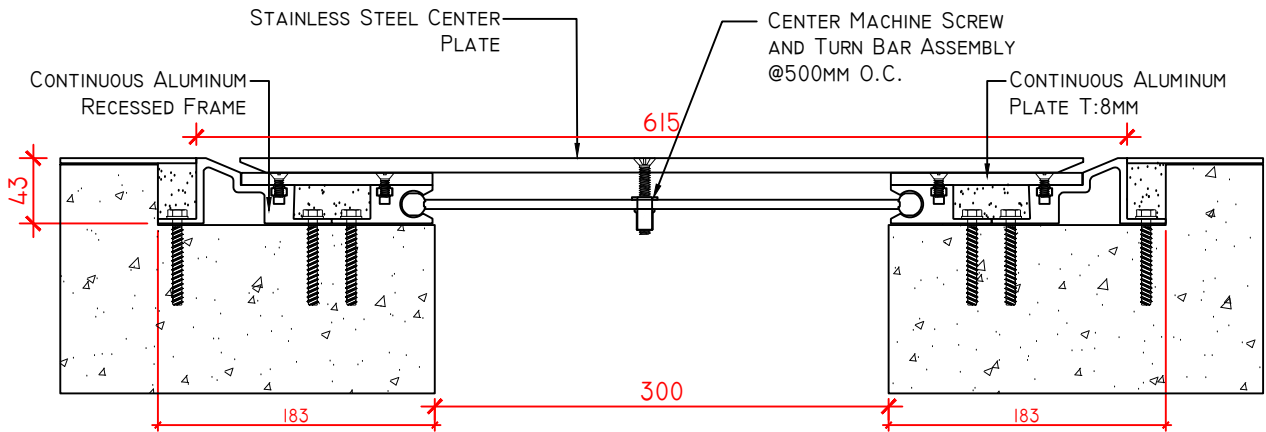

OPTION 2: Z-4100 + WATER BARRIER

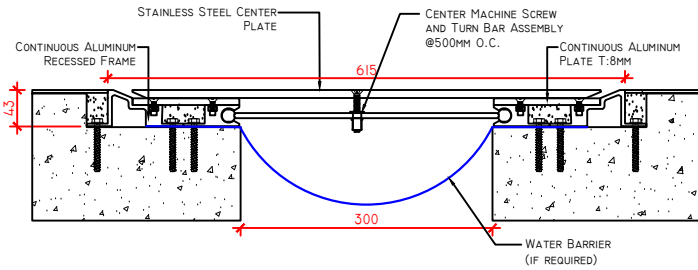

OPTION 3: Z-4100 + FIRE BARRIER

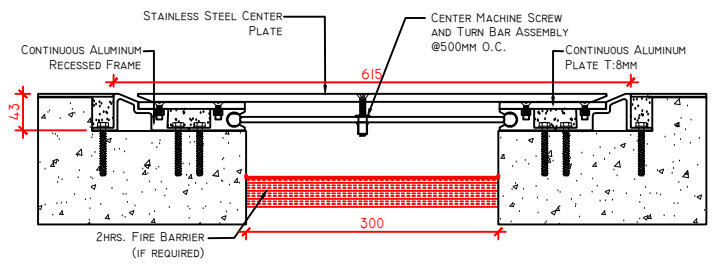

OPTION 4: Z-4100 + WATER BARRIER + FIRE BARRIER

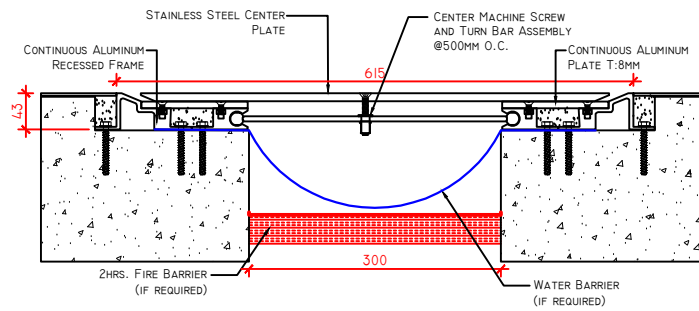

SKU	NAME	JOINT WIDTH, JW(MM)	HEIGHT, H(MM)	SIGHTLINE, S(MM)	MOVEMENT CAPACITY %	LOAD CAPACITY (KN)
Z410030043615SS	Z-4100-300SS	300	43	615	±50	30



PRODUCT TYPE: EXPANSION JOINT COVER

APPLICATION: FLOOR TO FLOOR CONDITION

APPROVED BY CLIENT: