

OPTION 1: ZK-4100

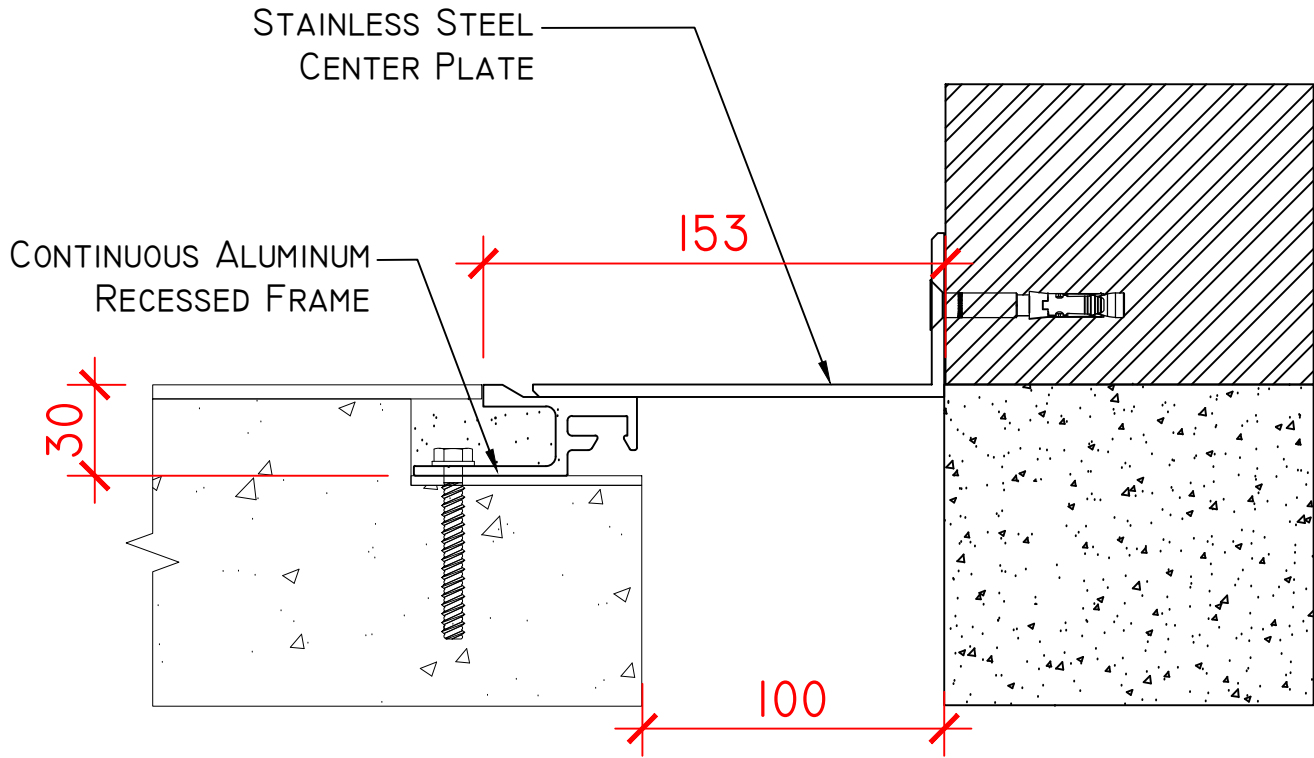

OPTION 2: ZK-4100 + WATER BARRIER

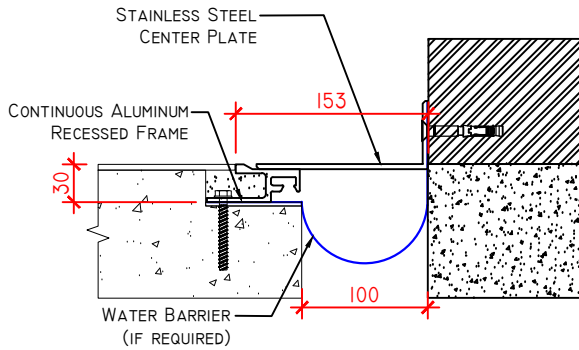

OPTION 3: ZK-4100 + FIRE BARRIER

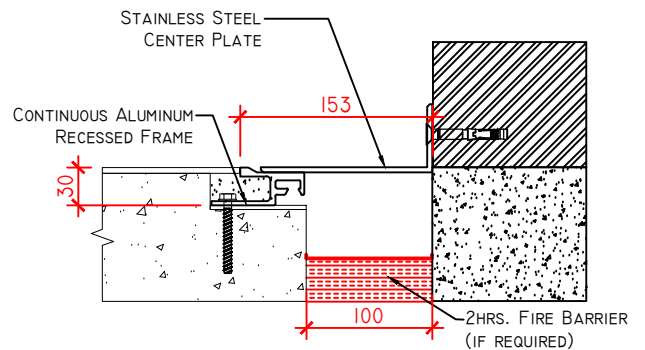

OPTION 4: ZK-4100 + WATER BARRIER + FIRE BARRIER

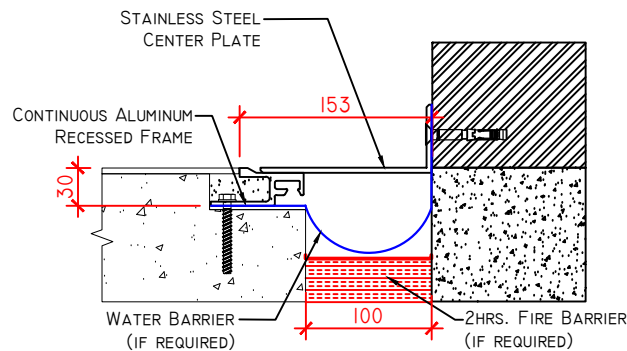

SKU	NAME	JOINT WIDTH, JW(MM)	HEIGHT, H(MM)	SIGHTLINE, S(MM)	MOVEMENT CAPACITY %	LOAD CAPACITY (KN)
ZK410010030153SS	ZK-4100-100SS	100	30	153	±50	35



**PRODUCT TYPE:** EXPANSION JOINT COVER

**APPLICATION:** FLOOR TO WALL CONDITION

**APPROVED BY CLIENT:**