

OPTION 1: ZK-4100

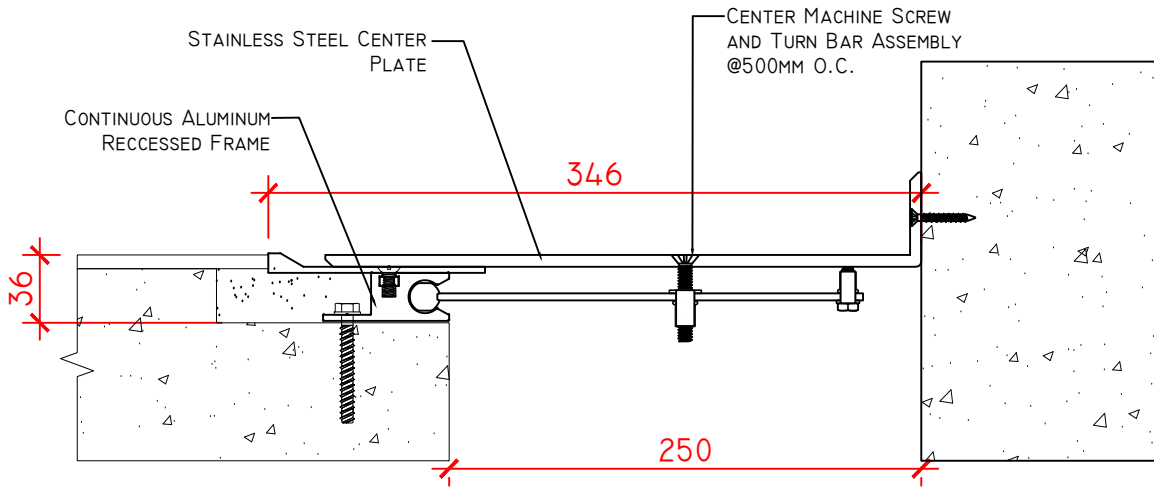

OPTION 2: ZK-4100 + WATER BARRIER

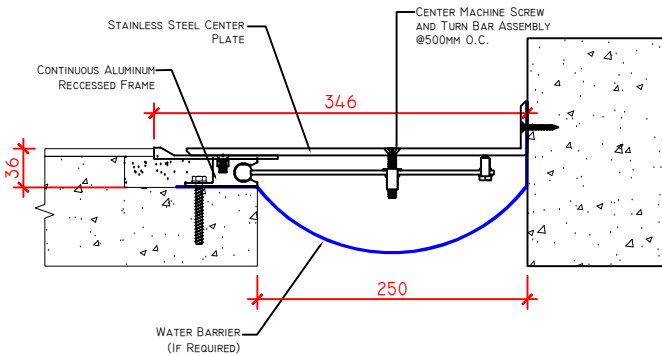

OPTION 3: ZK-4100 + FIRE BARRIER

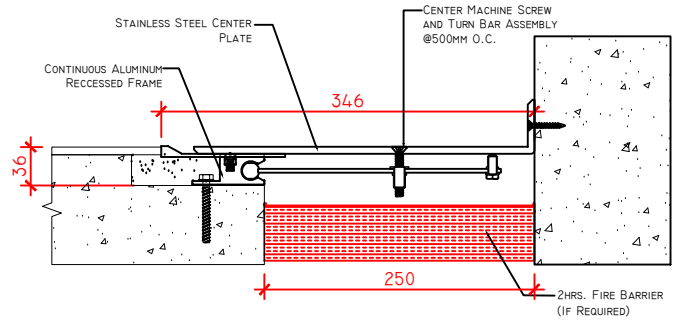

OPTION 4: ZK-4100 + WATER BARRIER + FIRE BARRIER

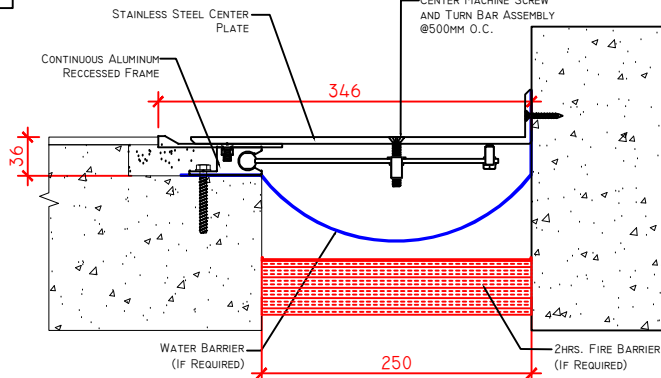

SKU	NAME	JOINT WIDTH, JW(MM)	HEIGHT, H(MM)	SIGHTLINE, S(MM)	MOVEMENT CAPACITY %	LOAD CAPACITY (KN)
ZK410025036346SS	ZK-4100-250SS	250	36	346	±50	30



**PRODUCT TYPE:** EXPANSION JOINT COVER  
**APPLICATION:** FLOOR TO WALL CONDITION  
**APPROVED BY CLIENT:**