

Micronizing
MC DecJet® 50
R&D



- Hundreds of installations worldwide
- Most advanced jet mill on the market
- Effective with more products than any other jet mill available today
- Highly efficient
- Single pass technology
- Handles sticky, abrasive and very hard products
- Scalable product range
- Easy to clean, absence of screws
- Accurate reproduction from development to production

Micronizing MC DecJet® 50 R&D



The MC DecJet® 50 is ideal for clinical trials and scale-ups, especially when extremely small batches of high value products with very low product loss need micronizing.

Technical features

High grade materials

AISI type 316L stainless steel mirror polished to RA 0.25 microns or Hastelloy

Rapid cleaning and easy validation

Ease and quickness in assembling and disassembling, as well as a limited number of components

The simplicity of the whole unit

Total absence of screws (replaced by tri-clip connections), no crevices, smooth and regular surfaces

Very low production loss

- Typical yields are 99.5 % of batch size, no blow-back phenomenon, limited caking of sticky powders
- One single collection point

Further advantages

- The lowest consumption of process gas of similarly sized units available on the market
- Process at constant temperature (endothermic)
- No heat generation
- Easy scale up maintaining the same PSD (Particle Size Distribution)

Options

- Volumetric or gravimetric pharma execution feeder with various hopper dimensions available

- Special internal lining: PTFE, PUR (Volkolan), ceramic, titanium nitride
- Sanitary rotary valve for production collection
- CIP and SIP systems
- Explosion proof systems (10 bars pressure resistant or burst disk)
- System fully automated by PLC

Alternative versions

Simplified versions based on the same pharma concept can be customized for other applications:

- Fine chemicals
- Cosmetics
- Food

Technical Data

Nominal diameter	Estimated capacity	Batch size	Process gas @ 7 bar	Process gas @ 12 bar	Installed power
50 mm 2 inches	35 - 200 g/h	1.5 - 500 g	0.19 Nm ³ /min (6.71 CFM)	0.33 Nm ³ /min (11.65 CFM)	0.05 kW 0.00 HP

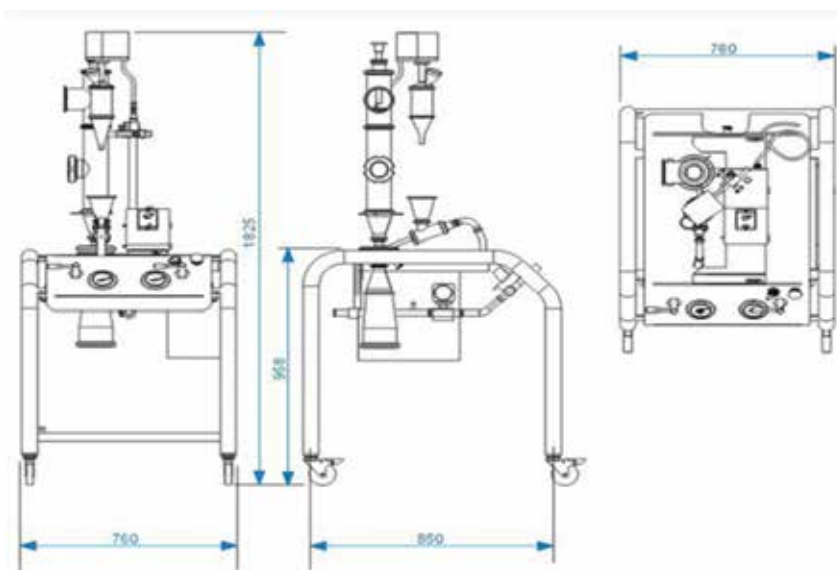

MC DecJet® - patented technology

Powder Handling Excellence

TEKEMAS