

MAXIMUM TORQUE NOT TO EXCEED 80,000 FT LBS.
 ULTIMATE CAPACITY IS CALCULATED BASED ON THE
 SITE-SPECIFIC SOIL PROFILE.

8 5/8" O.D. X 0.322" W.T. HELICAL PIPE PILE LEADS & EXTENSIONS

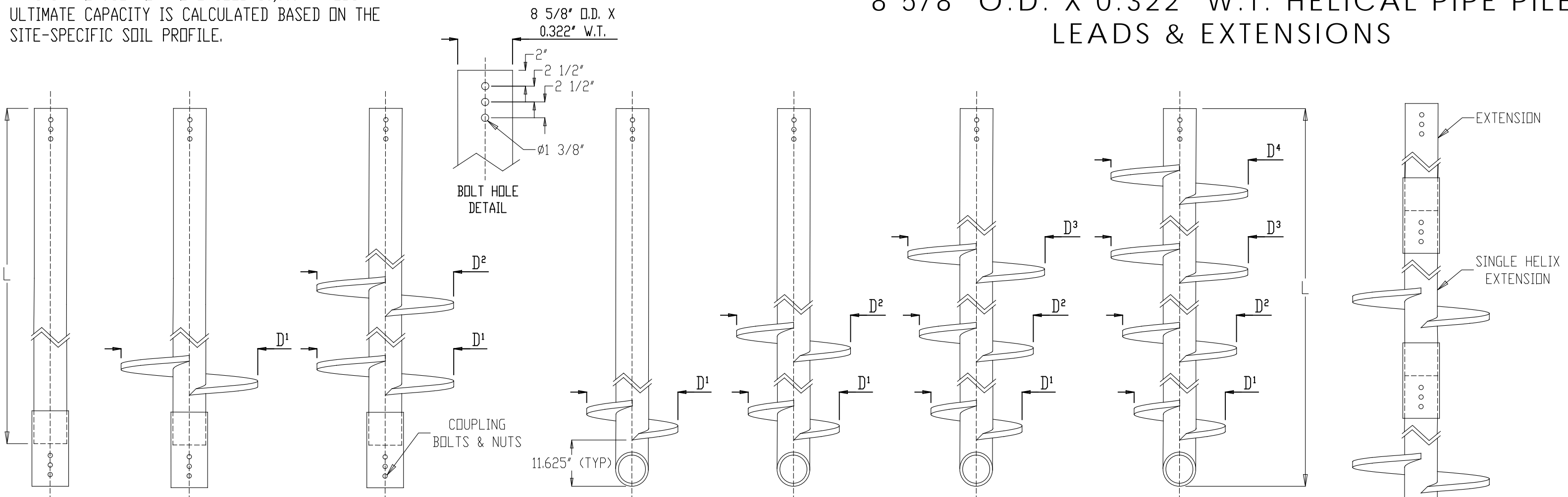

EXTENSION (EX: 858322EXTL)
 FLIGHTED EXTENSION SINGLE HELIX (SH) (EX: 858322FESHLD*XT)
 FLIGHTED EXTENSION DOUBLE HELIX (DH) (EX: 858322FEDHLD*D*XT)
 SINGLE HELIX (SH) LEAD (EX: 858322SHLD*XT)
 DOUBLE HELIX (DH) LEAD (EX: 858322DHLD*D*XT)
 TRIPLE HELIX (TH) LEAD (EX: 858322THLD*D*D*XT)
 QUAD HELIX (QH) LEAD (EX: 858322QHLD*D*D*D*XT)

NOTES:

1. SHAFT TO MEET OR EXCEED 55 KSI.
2. HELIX TO MEET OR EXCEED REQUIREMENTS OF ASTM A572/A1018/A656, 50 KSI.
3. ALL HELICES ARE FORMED BY PRESS DIE. LEADING EDGE OF HELICES ARE TAPERED TO IMPROVE INSTALLATION CAPABILITIES.
4. HELIX SPACING IS THREE (3) TIMES THE DIAMETER OF THE LOWER HELIX. SPACING OF LEADING HELIX ON FLIGHTED EXTENSIONS IS THREE (3) TIMES THE DIAMETER OF THE LAST HELIX ON THE PRECEEDING SHAFT.
5. STANDARD HELIX DIAMETERS ARE 16", 18", 20", 22" & 24". STANDARD HELIX THICKNESS IS 3/4".
6. ALL WELDING TO BE PERFORMED BY SHOP QUALIFIED WELDERS TO AWS D1.1 STRUCTURAL WELDING CODE - STEEL.
7. BARE STEEL IS STANDARD. GALVANIZING IS AVAILABLE IF REQUIRED.
8. (3) 1 1/4" DIAMETER X 11" LONG HEAVY HEX BOLT GRADE 8 AND (3) 1 1/4" HEAVY HEX NUT GRADE 8.
9. HELICAL PILE ASSEMBLIES MANUFACTURED IN ACCORDANCE WITH ICC-ES AC358 ACCEPTANCE CRITERIA FOR HELICAL FOUNDATION SYSTEMS AND DEVICES.

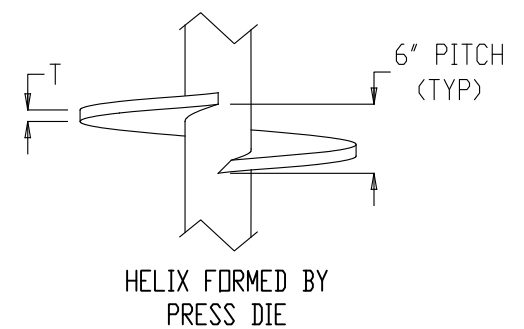

IDEAL PART # ABBREVIATIONS:
 858 = SHAFT DIAMETER
 322 = SHAFT WALL THICKNESS
 EXT = EXTENSION
 FE = FLIGHTED EXTENSION
 SH, DH, TH, QH = SINGLE, DOUBLE, TRIPLE, OR QUAD. HELIX
 L = SHAFT LENGTH IN FEET (EXAMPLE: 20' = 20)
 D = HELIX DIAMETER(S) IN INCHES (EXAMPLE: 20" = 20)
 X = X (SEPARATES HELIX DIAMETER(S) AND HELIX THICKNESS)
 T = HELIX THICKNESS (EXAMPLE: 3/4" = 34)
 G = GALVANIZED (IF REQUIRED)

PROPRIETARY AND CONFIDENTIAL
 THE INFORMATION CONTAINED IN THIS DRAWING IS THE SOLE PROPERTY OF IDEAL MANUFACTURING, INC. ANY REPRODUCTION IN PART OR AS A WHOLE WITHOUT WRITTEN PERMISSION OF IDEAL MANUFACTURING, INC. IS PROHIBITED.

DRAWING NO.	858322	IDEAL MANUFACTURING, INC. 999 PICTURE PARKWAY WEBSTER, NY 14580 800-789-4810
DRAWN BY: DSS	DATE: 07/21/17	
REVISION: 01	DATE: 08/21/17	DO NOT SCALE DRAWING SHEET 1 OF 1