

ANALYSIS OF GLASS RAIL BASE MOLDING ATTACHMENT

WJE Wiss, Janny, Elstner Associates, Inc. 330 Pfingsten Rd., Northbrook Illinois 60062	Made by: NSA	Sheet # 1/21
	Checked by: MJS	Project # 970798
Morse Industries Kent, Washington Glass Rail Base Molding Attachment Analysis		
	Date: 07/22/97	

Design Criteria

The purpose of these calculations is to check the adequacy of the connection of the Morse Industries glass hand railing base shoe molding (two types - see fig. 1) to either a concrete or steel substrate. The analysis considers the adequacy of the connection when when the standard height railing (42 in.) is subjected to live loads required by model building codes. The analysis is limited to the base shoe to substrate connection. Analysis of stresses in the glass, top rail, and base shoe molding are beyond the scope of these calculations.

Analysis of glass railing base shoe connections (4 types considered)

- Case 1: Concrete surface mounted (see fig. 2)
- Case 2: Concrete flush mounted (see fig. 3)
- Case 3: Steel fascia mounted (see fig. 4)
- Case 4: Steel fascia mounted (see fig. 5)

Model Code regulations require a uniform loading of 50 lbs per lineal foot (plf) or a 200-lb concentrated load to be resisted at the top rail, whichever creates the most severe stresses.

For the base shoe connection, the 200-lb load applied in a horizontal direction at the top handrail causes the maximum stresses in the connections.

The analysis considered shear and moment due to the 200 lb load being resisted by 3 - SAE Grade 5, 1/2" diameter cap screws ($F_u = 120,000$ psi and $F_y = 92,000$ psi) and 2 - ASTM A307, 3/8" diameter T-bolts ($F_u = 60,000$ psi)

Reference Standards

- The Aluminum Associations (AA), *Aluminum Design Manual*, Specifications & Guidelines for Aluminum Structures, October, 1994.
- American Architectural Manufacturers Association AAMA), *Metal Curtain Wall Fasteners* (AAMA TIR-A9-1991), 1991
- American Concrete Institute (ACI), *Building Code Requirements for Structural Concrete* (ACI 318-95), 1995.
- American Institute of Steel Construction (AISC), *Manual of Steel Construction* (Allowable Stress Design), 9th Edition, 1989.
- Industrial Fasteners Institute (IFI), *Fastener Standards*, 6th Edition, 1988
- International Conference of Building Officials (ICBO), *Uniform Building Code* (UBC), Structural Engineering Design Provisions, Volume 2, 1997.
- Precast/Prestressed Concrete Institute (PCI), *PSI Design Handbook*, MNL 120, 4th Edition, 1992.

Note: Relevant reference to these documents in the calculations is made with [] (square brackets).

WJE Wiss, Janny, Elstner Associates, Inc. 330 Pvingsten Rd., Northbrook Illinois 60062	Made by: NSA	Sheet # 2/21
	Checked by: MJS	Project # 970798
	Date: 07/22/97	
Glass Rail Base Molding Attachment Analysis		

Figure 1 - 6063-T6 Aluminum Base Shoe Moldings

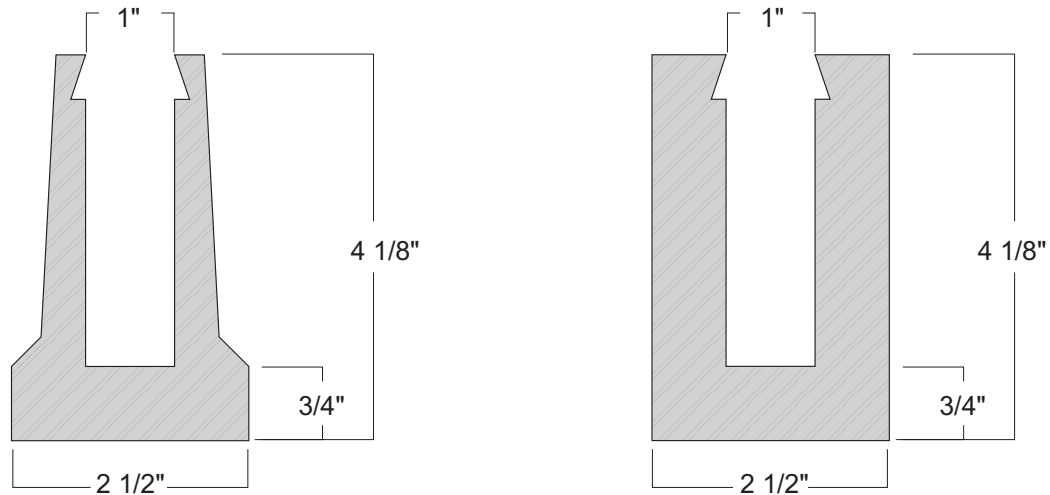
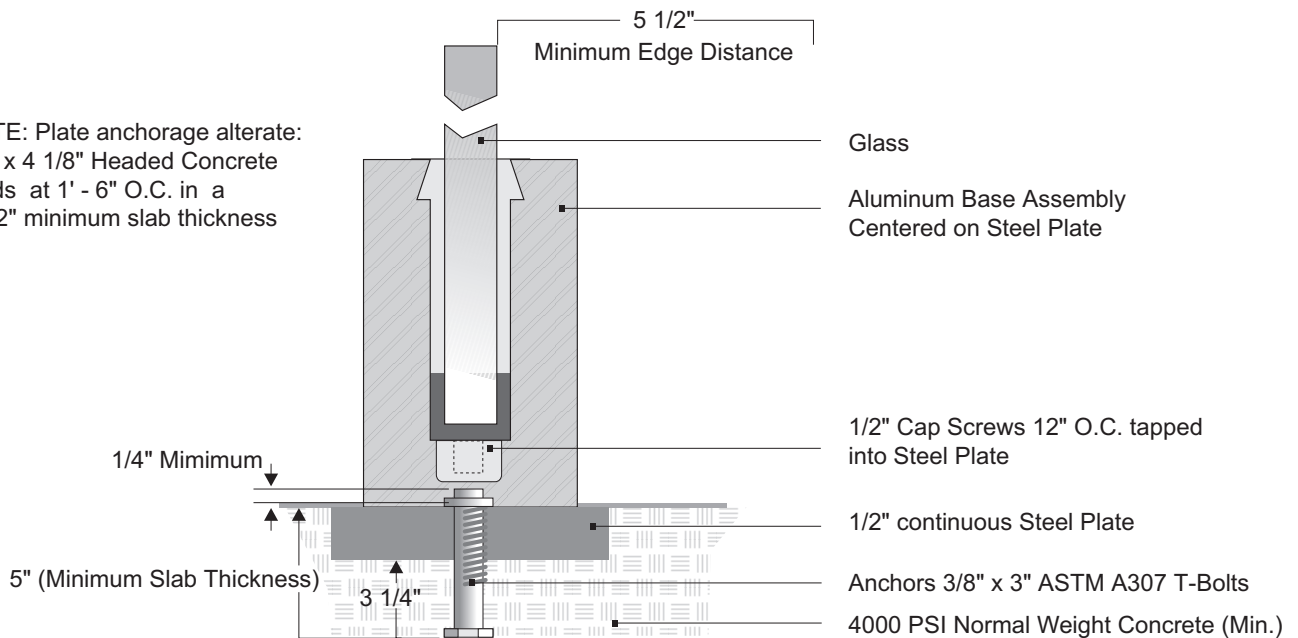

Figure 2 - Surface Mounted Base Shoe Molding

NOTE: Plate anchorage alterate:
 3/8" x 4 1/8" Headed Concrete
 Studs at 1' - 6" O.C. in a
 5 1/2" minimum slab thickness



ANALYSIS OF GLASS RAIL BASE MOLDING ATTACHMENT

WJE Wiss, Janny, Elstner Associates, Inc. 330 Pfingsten Rd., Northbrook Illinois 60062 Morse Industries Kent, Washington Glass Rail Base Molding Attachment Analysis	Made by: NSA	Sheet # 3/21
	Checked by: MJS	Project # 970798
	Date: 07/22/97	

Figure 3 - Flush Mounted Base Shoe Molding (recessed in concrete)

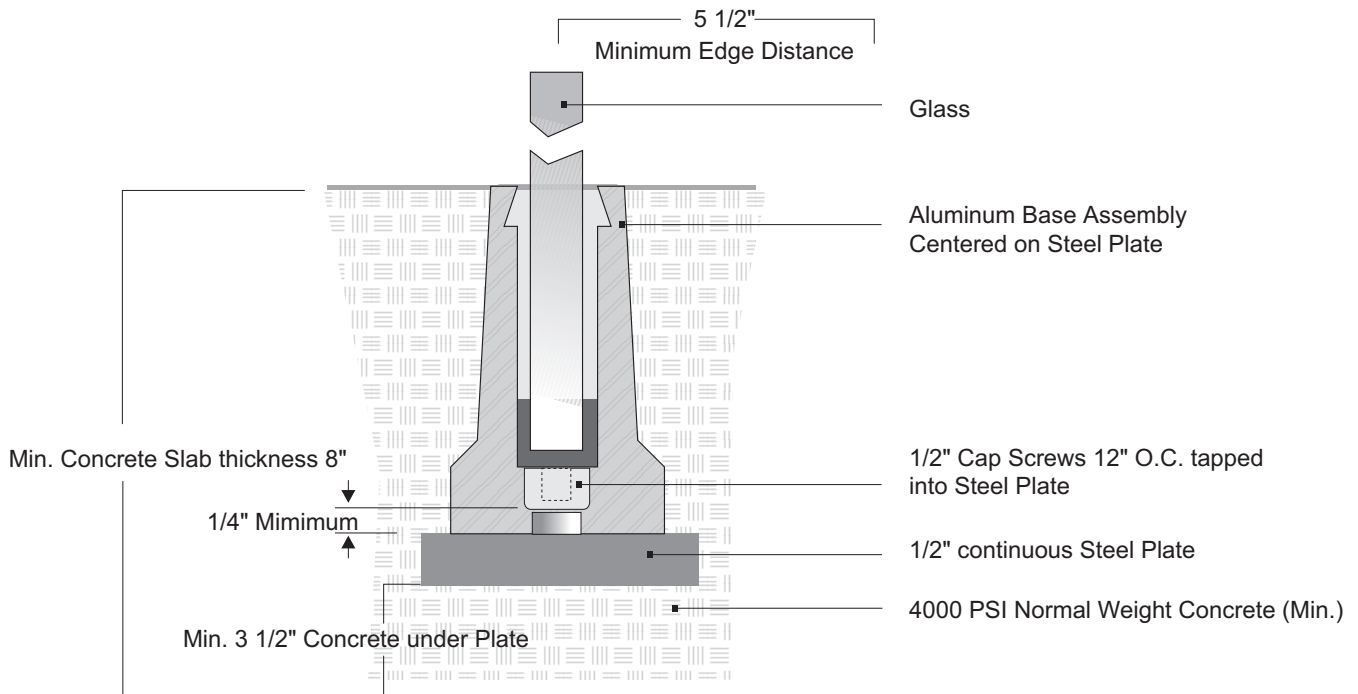
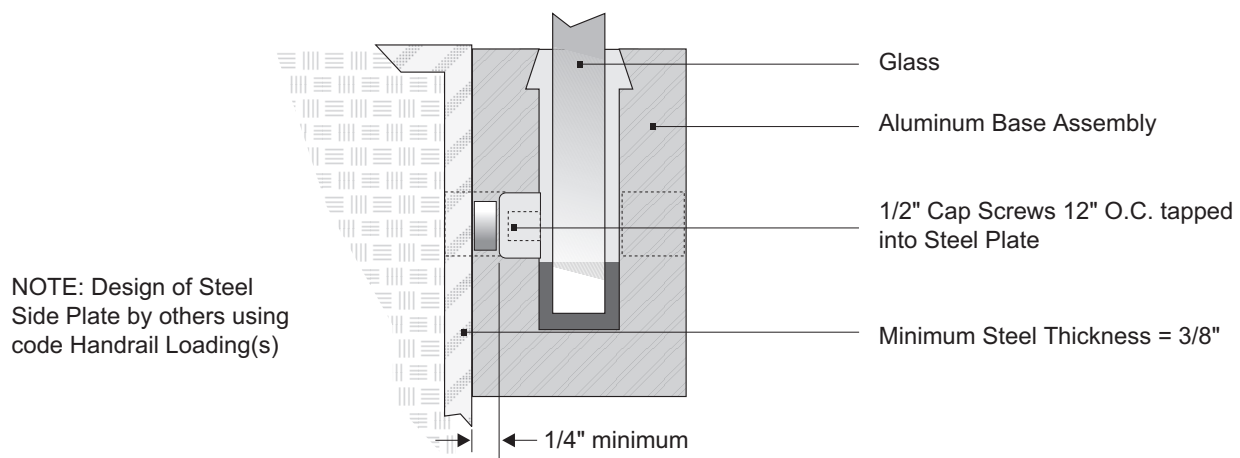

Figure 4 - Fascia Mounted Base Shoe Molding



NOTE: Design of Steel Side Plate by others using code Handrail Loading(s)

ANALYSIS OF GLASS RAIL BASE MOLDING ATTACHMENT

WJE Wiss, Janny, Elstner Associates, Inc. 330 Pfingsten Rd., Northbrook Illinois 60062 Morse Industries Kent, Washington Glass Rail Base Molding Attachment Analysis	Made by: NSA	Sheet # 4/21
	Checked by: MJS	Project # 970798
	Date: 07/22/97	

Figure 5 - Fascia Mounted Base Shoe Molding

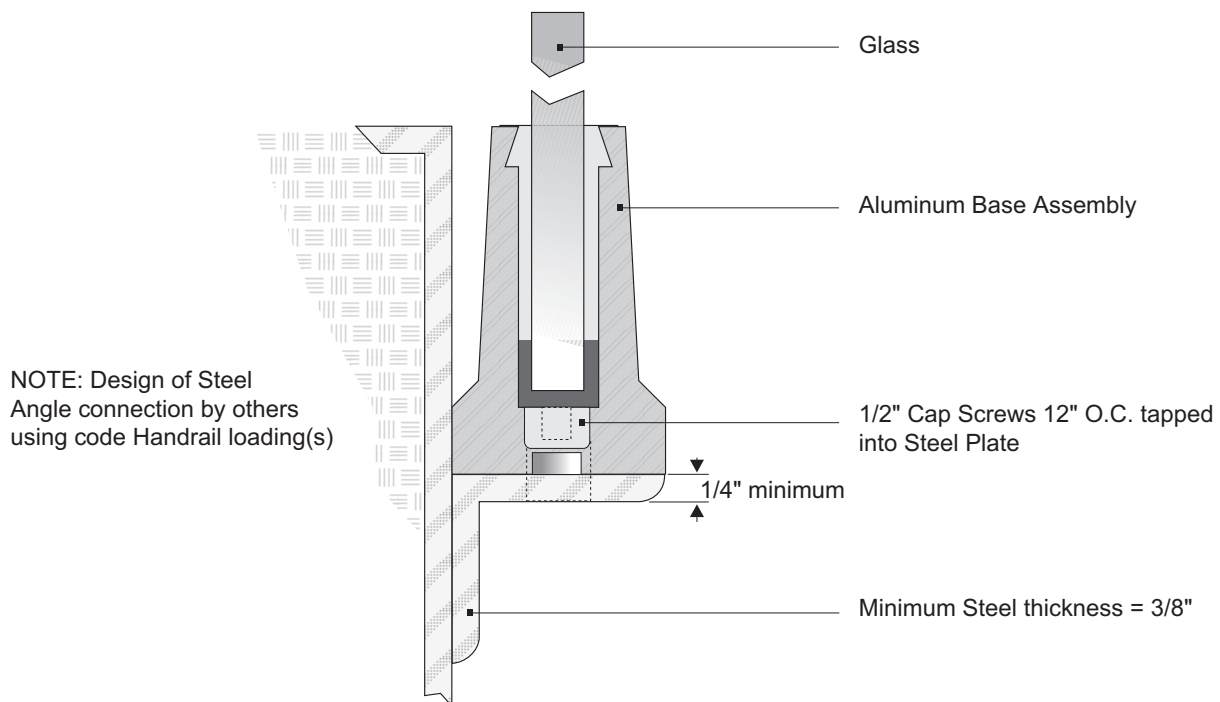

ANALYSIS OF GLASS RAIL BASE MOLDING ATTACHMENT

WJE Wiss, Janny, Elstner Associates, Inc. 330 Pfingsten Rd., Northbrook Illinois 60062	Made by: NSA	Sheet # 5/21
	Checked by: MJS	Project # 970798
Morse Industries Kent, Washington	Date: 07/22/97	
Glass Rail Base Molding Attachment Analysis		

Analysis of Glass Railing Base Shoe Connections

Railing Load

(Ref: 1997 UBC)

per Table 16-B:

Lateral Load 50 lbs/ft

Concentrated Load 200 lbs.
(not acting cumulatively with the above load)

Application

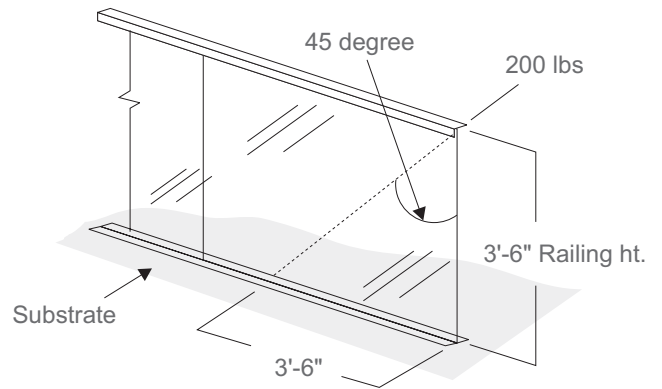

200 lbs at end of railing
(into page - see above)

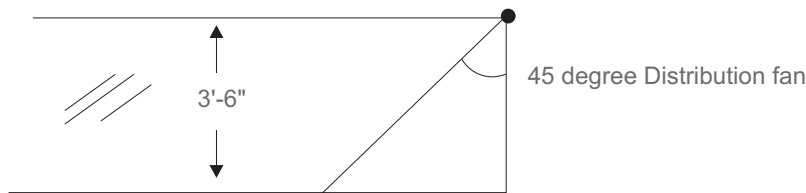

Maximum end distance assumed

WJE Wiss, Janny, Elstner Associates, Inc. 330 Pfingsten Rd., Northbrook Illinois 60062	<i>Made by:</i> NSA	<i>Sheet #</i> 6/21
	<i>Checked by:</i> MJS	<i>Project #</i> 970798
Morse Industries Kent, Washington Glass Rail Base Molding Attachment Analysis		<i>Date:</i> 07/22/97

Material Assumptions

- Cap Screws
 SAE Grade 5, 1/2" \varnothing Screws
 $F_u = 120$ ksi (ultimate)
- T-Bolts
 ASTM A307, 3/8" \varnothing
 $F_y = 92$ ksi (yield)
 $F_u = 60$ ksi (ultimate)
- Aluminum Base Shoe Molding
 Alloy 6063 -T6
- Concrete (Substrate)
 $F_c = 4000$ psi (minimum)
- Steel (Substrate)
 ASTM A36 $F_y = 36$ ksi (minimum)

Base Shoe Connection Types

- Case 1 Concrete surface mounted (recessed molding)
- Case 2 Concrete flush mounted (vertically attached)
- Case 3 Steel fascia mounted (horizontally attached)
- Case 4 Steel fascia mounted

ANALYSIS OF GLASS RAIL BASE MOLDING ATTACHMENT

WJE Wiss, Janny, Elstner Associates, Inc. 330 Pflugsten Rd., Northbrook Illinois 60062	Made by: NSA	Sheet # 7/21
	Checked by: MJS	Project # 970798
	Date: 07/22/97	

Glass Rail Base Molding Attachment Analysis

Caes 1 Analysis

Configuration

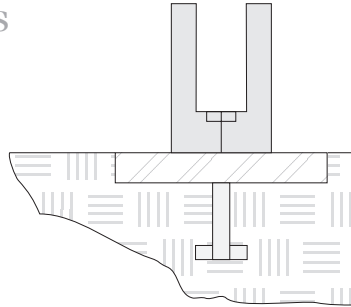

1/2" Ø Cap Screws, 1'-0" o.c.

3/8" Cap Bolts, 1'-6" o.c.

Applied Loads (Service)

Maximum at base: Shear $V = 200 \text{ lbs} \rightarrow$

Moment $M = (200 \text{ lbs})(42") = 8400 \text{ in-lbs}$

These loads act over a 3'-6" horizontal width, assuming a 45 degree distribution of load (page 1).

Cap Screw Connection (Screw & Aluminum checks)

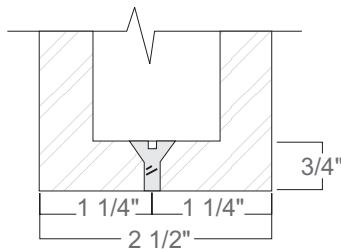

Free Body Diagram

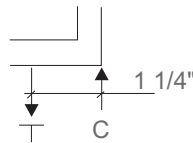

Molding assumed to be Relatively stiff

$\therefore \text{Arm} = 1-14"$

Tensile Load on One Cap Screw

$$M = 1.25 T$$

$$T = M/1.25 = 8400/1.25 = 6720 \text{ lbs}$$

Conservatively, assume 3 cap screws are effective (pg 1)

$$6720/3 = 2240 \text{ lbs}$$

WJE Wiss, Janny, Elstner Associates, Inc. <i>330 Pfingsten Rd., Northbrook Illinois 60062</i>	Made by:	NSA	Sheet #	8/21
	Checked by:	MJS	Project #	970798
	Date:	07/22/97		
Morse Industries Kent, Washington		Glass Rail Base Molding Attachment Analysis		

Tensile Allowable

$$F_t = 0.33 F_u \text{ (AISC Manual of Steel Construction)}$$

$$= 0.33(120 \text{ ksi}) = 40 \text{ ksi}$$

$$\text{Area} = \pi d^2 / 4 = \pi (.5)^2 / 4 = 0.196 \text{ sq. in.}$$

$$T_{\text{allow}} = F_t A = (40 \text{ ksi})(0.196 \text{ in}^2) = 7.84 \text{ kips} = 7840 \text{ lbs}$$

$$7840 \# > 2240 \text{ lbs} \quad \text{ok}$$

Shear Load on Cap Screw

$$V = 200/3 = 66.7 \text{ lbs}$$

Shear Allowable

$$F_v = 0.17 F_u \text{ (AISC Manual - threads included)}$$

$$= 0.17 (120) = 20.4 \text{ ksi}$$

$$V_{\text{allow}} = F_v A = (20.4 \text{ ksi})(0.96 \text{ in}^2) = 3.99 \text{ kips} = 4000 \text{ lbs}$$

$$4000 > 66.7 \quad \text{ok}$$

Combined

By observation → ok

Check Screw Bearing on Aluminum

Screw shank length brg on AL: $3/4" - 0.21 = 0.54 \text{ in}$ ← Countersunk Head
 (Ref. IFI Stds) $3/4" - 0.5 \text{ in} = 0.25 \text{ in}$ ← Socket Head

$$\text{Bearing Area} = (.5)(.25 \text{ in}) = 0.125 \text{ in}^2$$

Allowable bearing stress on aluminum (Aluminum Spec. '94)

Table 2-23 $F_p = 24 \text{ ksi}$

WJE Wiss, Janny, Elstner Associates, Inc. 330 Pfingsten Rd., Northbrook Illinois 60062 Morse Industries Kent, Washington Glass Rail Base Molding Attachment Analysis	Made by: NSA	Sheet # 9/21
	Checked by: MJS	Project # 970798
	Date: 07/22/97	

$$V_{allow} = F_p A_{brg} = (24 \text{ ksi})(0.125 \text{ in}) = 3.0 \text{ kips}$$

$$3000 \text{ lbs} > 66.7 \text{ lbs} \quad \text{ok}$$

Check Screw Pullout in Aluminum

Countersunk Head

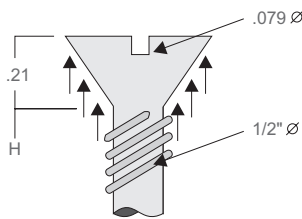

$$A_p = \pi/4 (.79^2 - .5^2)$$

$$= 0.294 \text{ in}^2$$

$$A_v = \pi dh$$

$$= \pi(.79)(3/4" - .21)$$

$$= 1.34 \text{ in}^2$$

Socket Head

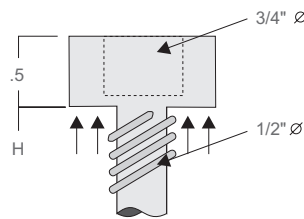

$$A_p = \pi/4 (.75^2 - .5^2)$$

$$= 0.245 \text{ in}^2$$

$$A_v = \pi dh$$

$$= \pi(.75)(.25)$$

$$= 0.589 \text{ in}^2 \quad \leftarrow \text{critical}$$

~ Bearing Under Head

$F_p = 16 \text{ ksi}$ (conservative) on Flat surfaces ~ brg.

$$T_{allow} = F_p A_p = (16 \text{ ksi})(.245 \text{ in}^2) = 3.92 \text{ kips} = 3920 \text{ lbs}$$

>2240 lbs ok

~ Shear Plug

$F_v = 8.5 \text{ ksi}$ (Aluminum Spec '94)

$$V_{allow} = F_v A_v = (8.5 \text{ ksi})(.589 \text{ in}^2) = 5 \text{ kips}$$

>2240 lbs ok

WJE Wiss, Janny, Elstner Associates, Inc. 330 Pfingsten Rd., Northbrook Illinois 60062 Morse Industries Kent, Washington Glass Rail Base Molding Attachment Analysis	Made by: NSA	Sheet # 10/21
	Checked by: MJS	Project # 970798
	Date: 07/22/97	

Cap Screw into Steel Plate

1/2" thick Steel Plate

(Ref: "Metal Curtain Wall Fasteners", from AAMA)

Table 4 Thread Stripping Area - Internal (sq. in. / thread)

$$1/2" \varnothing \quad TSA(l) = 0.036$$

$$\text{Number of Threads / Inch} \quad N = 13 \quad (\text{UNC})$$

$$\text{Min. PL - Thickness to achieve Tension Force} = \frac{\text{Allowable Tension}}{\text{Allow. Shear Stress} \cdot TSA(l) \cdot (N) + \frac{1}{N}}$$

$$MT = \frac{7840 \text{ lbs}}{(.4)(36,000)(0.86)(13)} + \frac{1}{13}$$

$$F_v = .4F_y$$

$$\frac{7840}{16099} + \frac{1}{13} = 0.56 \text{ in} \quad 1/2" \text{ PL provided}$$

$$\text{Reduction Factor} = .5 / .56 = 0.88$$

$$T_{\text{allow}} = (7840 \text{ lbs})(.88) = 6900 \text{ lbs}$$

>2240 lbs ok

Anchor in Concrete (Steel check)

3/8" \varnothing A307 bolts assumed to act as studs.

Bolt Tension

4 in wide plate assume Arm = 4/2 = 2 in

On page 1, 2 stud bolts assumed effective

$$T = \frac{M}{\text{Arm}} = \frac{8400 \text{ in lbs}}{(2 \text{ in})(2 \text{ bolts})} = 2100 \text{ lbs/bolt}$$

WJE Wiss, Janny, Elstner Associates, Inc. 330 Pfingsten Rd., Northbrook Illinois 60062 Morse Industries Kent, Washington Glass Rail Base Molding Attachment Analysis	Made by:	NSA	Sheet #	11/21
	Checked by:	MJS	Project #	970798
	Date:	07/22/97		

Allowable Tension

(Ref: AISC Manual) $F_t = 20 \text{ ksi}$

$$\text{Area} = \pi(3/8")^2 / 4 = 0.11 \text{ in}^2$$

$$T \text{ allow} = (20 \text{ ksi})(.11 \text{ in}^2) = 2.2 \text{ kips} = 2200 \text{ lbs}$$

>2100 lbs ok

Shear in Bolt

$$200 \text{ lbs} / 2 \text{ bolts} = 100 \text{ lbs} \rightarrow$$

Allowable Shear

$$F_v = 10 \text{ ksi} \quad (\text{Ref. AISC Manual})$$

$$V \text{ allow} = (10 \text{ ksi})(.11) = 1100 \text{ lbs}$$

>100 lbs ok

Check Interaction

(AISC Table J3.3) $F_t = 26 - 1.8 F_v < 20$

actual $F_v = 100/.11 = 909 \text{ psi}$

$F_t = 2100/.11 = 19,090 \text{ psi} = 19.1 \text{ ksi}$

Allowable

$$\therefore F_t = 26 - 1.8(0.91 \text{ ksi}) = 24.36 \text{ ksi} \quad \text{use } 20 \text{ ksi as default}$$

$$F_t > f_t \quad \text{ok}$$

ANALYSIS OF GLASS RAIL BASE MOLDING ATTACHMENT

WJE Wiss, Janny, Elstner Associates, Inc. 330 Pfingsten Rd., Northbrook Illinois 60062 Morse Industries Kent, Washington Glass Rail Base Molding Attachment Analysis	Made by: NSA	Sheet # 12/21
	Checked by: MJS	Project # 970798
	Date: 07/22/97	

Check Steel Plate

1/2" thick \mathbb{R} , studs at 18in oc.

Assume 6" of plate is tributary to resist bending

$$s = \frac{bd^2}{6} = \frac{(6")(0.5")^2}{6} = 0.25 \text{ in}^3$$

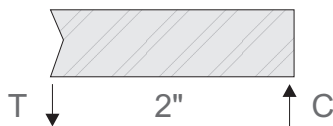

$$= 2100 \text{ lbs}$$

$$M = (2100 \text{ lbs})(2") = 4200 \text{ in lbs}$$

$$F_b = \frac{m}{s} = \frac{(4.2 \text{ in kips})}{.25 \text{ in}^3} = 16.8 \text{ ksi}$$

$$F_b = 0.75 F_y = 0.75 (36) = 27 \text{ kis } \underline{\text{ok}}$$

Check Stud in Concrete

(Ref: PCI Design Handbook, 4th edition, Chapter 6)

Factored Loads (refer to pages 6& 7)

$$V = (100 \text{ lbs})(1.7) = 170 \text{ lbs}$$

$$T = (2100 \text{ lbs})(1.7) = 3570 \text{ lbs}$$

Bolt Geometry

As a practical minimum, select a 3" long bolt

(AISC Manual) 3/8" hex head bolt $F = 9/16"$ (dist. across flats)

Pull - Out Cone (Tension)

$$l_e = 3 \text{ in} \quad A_o = \sqrt{2} l_e \pi (l_e = d_h)$$

$$d_h = 9/16 \text{ in} \quad = \sqrt{2} (3) (\pi) [3.5625"] = 47.5 \text{ in}^2$$

WJE Wiss, Janny, Elstner Associates, Inc. 330 Pvingsten Rd., Northbrook Illinois 60062 Morse Industries Kent, Washington Glass Rail Base Molding Attachment Analysis	Made by:	NSA	Sheet #	13/21
	Checked by:	MJS	Project #	970798
	Date:	07/22/97		

$$F'c = 4000 \text{ psi (mimimum)}$$

$$\begin{aligned} \ell_{pc} &= \ell_{Ao} (2.8 \times \sqrt{F'c}) \\ &= (0.85) (47.5) (2.8) \sqrt{4000} \\ &= 7150 \text{ lbs} \quad > 3570 \text{ obs ok} \end{aligned}$$

Shear

$$\text{Min. edge distance} = 15Db = 15 (3/8") = 5.625 \text{ in}$$

$$\begin{aligned} \ell_{Vc} &= \ell_{628db^2} \lambda \sqrt{f'c} \eta \quad \text{where } \eta = \text{number of studs} \\ &= (.85) (628) (.375)^2 (1.0) \sqrt{4000} (1.0) \\ &= 4750 \text{ lbs} \quad > 170 \text{ lbs ok} \end{aligned}$$

Examine Shear Parameters

$$\begin{aligned} \text{Bolt length} + \text{R Thickness} &= 3" + 1/2" = 3 1/2" \\ \text{Say practical min. edge dist.} &= 1.5 (3.5) = 5 1/4" = de \end{aligned}$$

$$\begin{aligned} \ell_{Vc} &= \ell_{12.5 de} \lambda \sqrt{f'c}^{1.5} \\ &= (.85)(12.5)(5.25)^{1.5} (1.0) \sqrt{4000} = 8085 \text{ lbs} \end{aligned}$$

* Width Effect $C_w = 1.0$ (only one stud in group)

* Thickness Effect $= \frac{h}{C_t} \leq 1.0$
 $C_t = 1.3de$

Only becomes a factor when $h < 1.3(5 1/4) = 6 7/8"$
 Select $h = 5 \text{ in}$ $C_t = \frac{5}{6.875} = 0.73$

* Corner Effect $C_c = 1.0$

→ Keep edge distance >5 1/4" in both directions.

WJE Wiss, Janny, Elstner Associates, Inc. 330 Pfingsten Rd., Northbrook Illinois 60062 Morse Industries Kent, Washington Glass Rail Base Molding Attachment Analysis	Made by:	NSA	Sheet #
	Checked by:	MJS	14/21
	Date:	07/22/97	Project #
			970798

$$\begin{aligned} \ell V_c &= \ell V'_c C_w C_t C_c \\ &= (8085 \text{ lbs.}) (1.0) (0.73) (1.0) \\ &= 5092 \text{ lbs} \end{aligned}$$

Other eqn still governs

(Note: A 5" min. slab thickness is a practical minimum for this R. & bolt combination)

Check Combined

$$P_c = 7150 / .85 = 8412 \text{ lbs}$$

$$V_c = 4750 / .85 = 5588 \text{ lbs}$$

$$\frac{1}{\ell} \left[\left(\frac{P_u}{P_c} \right)^2 + \left(\frac{V_u}{V_c} \right)^2 \right] \leq 1.0$$

$$\frac{1}{.85} \left[\left(\frac{3750}{8412} \right)^2 + \left(\frac{170}{5588} \right)^2 \right] \leq 1.0$$

$$\frac{1}{.85} [.18 + .001] \leq 1.0$$

$$0.2 \leq 1.0 \quad \text{ok}$$

Weld bolt to plate

$$3/8" \text{ } \emptyset \text{ Length} = 2\pi r_v = (3/8") (\pi) = 1.178$$

$$T = 2100 \text{ lbs} = 2.1 \text{ kips}$$

$$V = 100 \text{ lbs} = 0.1 \text{ kips}$$

$$\text{E70 electrodes} \quad F_v = (.3) (70 \text{ ksi}) = 21 \text{ ksi}$$

$$\begin{aligned} 3/16" \text{ weld} \quad R_w (3/16") (.707) (21 \text{ ksi}) (1.178") \\ = 3.3 \text{ kips} \quad \text{ok} \end{aligned}$$

No need to check interaction as tension dominates

ANALYSIS OF GLASS RAIL BASE MOLDING ATTACHMENT

WJE Wiss, Janny, Elstner Associates, Inc. 330 Pfingsten Rd., Northbrook Illinois 60062	Made by: NSA	Sheet # 15/21
	Checked by: MJS	Project # 970798
Morse Industries Kent, Washington		Date: 07/22/97
Glass Rail Base Molding Attachment Analysis		

Case 2 Analysis

Configuration

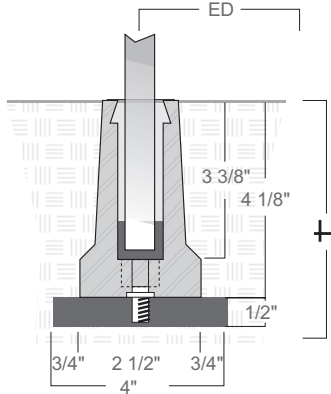

200 lbs over 42" width

$$M = (200) (42) = 8400 \text{ in lbs}$$

$$= 8.4 \text{ in kips}$$

(at finish floor elev.)

$$M = (200) (42" + 4 \frac{1}{8}")$$

$$= 9225 \text{ in lbs}$$

$$M_u = 1.7 (9.23)$$

$$= 15.7 \text{ in kips}$$

$$V_u = 1.7 (0.2) = 0.34 \text{ kips}$$

Evaluate a Resisting Couple in the Molding

FBD

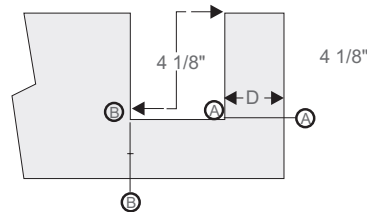

$$N \approx \frac{M}{4 \frac{1}{8}"} = 15.7 / 4.125 = 3.81 \text{ kips}$$

or

$$M_A = N(4 \frac{1}{8} ") = 15.7 \text{ in kips}$$

Section A-A

Analyze as a plain concrete section

(Ref: ACI 318-95)

Section 9.3.5 $\ell = 0.65$ Strength reduction factor

Chapter 22 ~ Structural Plain Concrete

$$M_u = \ell M_n = \ell 5 \sqrt{f'_c} S \quad [\text{Eq'n 22-2}]$$

WJE Wiss, Janny, Elstner Associates, Inc. 330 Pfingsten Rd., Northbrook Illinois 60062 Morse Industries Kent, Washington Glass Rail Base Molding Attachment Analysis	Made by: NSA	Sheet # 16/21
	Checked by: MJS	Project # 970798
	Date: 07/22/97	

Determine req'd section modulus ~ S

$$M_u = \ell \cdot 5 \sqrt{f'_c} S$$

$$S = \frac{M_u}{\ell \cdot 5 \sqrt{f'_c}} = \frac{15,700 \text{ in lbs}}{(.65)(5) \sqrt{4000}}$$

Determine min. width req'd

$$5 = \frac{bd^2}{6} \quad d = \sqrt{\frac{6S}{b}} = \sqrt{\frac{6(76.4)}{42}} = 3.3 \text{ in}$$

where b = 42" (effective width resisting the load, p.1)

From center of railing to edge

$$ED = 4/2 + 3.3 = 5.3 \text{ in} \quad \text{say } 5 \frac{1}{2} \text{ in min.}$$

~ Shear across interface

$$\begin{aligned} \ell V_n &= \ell \left(\frac{4}{3}\right) \sqrt{f'_c} b_h \quad [\text{Eq'n 22-8}] \\ &= (6.5) \left(\frac{4}{3}\right) \sqrt{4000} (42") (3.5) (1/1000) \\ &= 8.1 \text{ kips} \quad \text{ok} \end{aligned}$$

Section B-B

Slight increase in moment; the depth at B-B will be at least 3 1/2"

$$\begin{aligned} \text{Arm} &= (42" + 4 \frac{5}{8}" + 3.5/2) = 48.375 \\ M_u &= (1.7) (48.375) (0.2 \text{ kips}) = 16.45 \text{ in kips} \end{aligned}$$

~ Check 3 1/2 in of concrete below R

$$S = \frac{bd^2}{6} = \frac{(42") (3.5)^2}{6} = 85.75 \text{ in}^3$$

$$\begin{aligned} \ell M_n &= \ell \cdot 5 \sqrt{f'_c} S = (.65) 5 \sqrt{4000} (85.75) (1/1000) \\ &= 17.63 \text{ in kips} > 16.45 \text{ in kips} \quad \text{ok} \end{aligned}$$

ANALYSIS OF GLASS RAIL BASE MOLDING ATTACHMENT

WJE Wiss, Janny, Elstner Associates, Inc. 330 Pfingsten Rd., Northbrook Illinois 60062 Morse Industries Kent, Washington Glass Rail Base Molding Attachment Analysis	Made by: NSA	Sheet # 17/21
	Checked by: MJS	Project # 970798
	Date: 07/22/97	

~ Shear across section

Glass weighs 15 psf/lin thickness

3/4" thick glass ~w = 11.3 psf

1 ft width:

$$w = (11.3 \text{ psf}) (4 \text{ ft}) = 45.2 \text{ lbs/ft.}$$

Where 4 ft height includes top handrail wt. (approx)

$$W_u = (1.4) (45.2/\text{ft.}) + (1.7) (50) = 148 \text{ lbs over 1 ft}$$

Effective Width = 3.5 ft

$$W_u (148 \text{ lbs/ft}) (3.5 \text{ ft}) = 520 \text{ lbs} \ll 8.1 \text{ kips} \quad \text{ok}$$

Evaluate a Resisting Couple in the Steel Plate

FBD

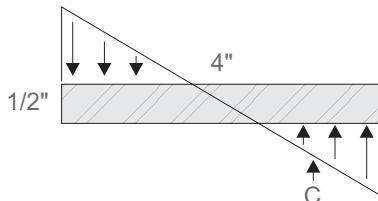

$$M = 15.7 \text{ in. kips}$$

$$\text{Arms} = 2/3 (4") = 2.667"$$

$$C \approx \frac{15.7}{2.667} = 5.9 \text{ kips}$$

By inspection, the concrete section (3 1/2" min.) below this has the necessary capacity to resist the moment & shear (C force) at the previously identified section B-B.

At the top, the upward reacting C force acts over an area:

$$A = (3/4") (42") = 31.5 \text{ sq. in.}$$

Check concrete bearing

$$F_p = \frac{5900 \text{ lbs}}{31.5 \text{ in}^2} = 187 \text{ psi}$$

Allowable [ACI 22.5.5]

$$F_p = \phi 0.85 f_c = (.65) (.85) (4000 \text{ psi}) = 2210 \text{ psi} \quad \text{ok}$$

ANALYSIS OF GLASS RAIL BASE MOLDING ATTACHMENT

WJE Wiss, Janny, Elstner Associates, Inc. 330 Pvingsten Rd., Northbrook Illinois 60062 Morse Industries Kent, Washington Glass Rail Base Molding Attachment Analysis	<i>Made by:</i> NSA	<i>Sheet #</i> 18/21
	<i>Checked by:</i> MJS	<i>Project #</i> 970798
	<i>Date:</i> 07/22/97	

Evaluate Cap Screw Fastener

Moment slightly higher $M = 9225$ in lbs (see page 11)

$T = M/1.25" = 9225/1.5 = 7380$ lbs

3 cap screws effective $7380/3 = 2460$ lbs

Allowables

(page 4) screw tensile allowable = 7840 lbs ok

(page 5) tensile brg under head = 3920 lbs → ok

→

: screw connection remains ok

WJE Wiss, Janny, Elstner Associates, Inc. 330 Pfingsten Rd., Northbrook Illinois 60062	Made by: NSA	Sheet # 19/21
	Checked by: MJS	Project # 970798
	Date: 07/22/97	

Glass Rail Base Molding Attachment Analysis

Case 3 Analysis: Configuration

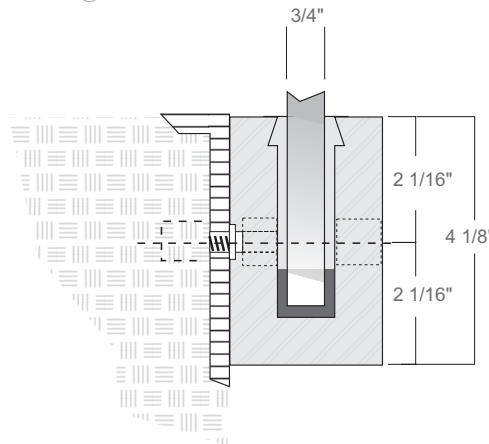

(from page 11 & 13)
 conservatively say
 $M = 9225 \text{ in lbs}$
 $N = 200 \text{ lbs} \rightarrow$
 $P = \text{glass wt.}$
 $= (3.5') (45 \text{ lbs/ft})$
 $= 158 \text{ lbs} \downarrow$

Cap Screw Connection

Tensile Load on One Cap Screw

Again, conservatively assume that 3 screws are effective

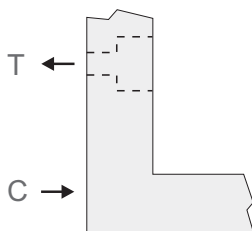

Arm = $2 \frac{1}{16}$ "

$$T = \frac{M}{\text{Arm}} = \frac{9225 \text{ in lbs}}{(2 \frac{1}{16}) (3 \text{ screws})} = 1491 \text{ lbs}$$

(page 4) T allow = 7840 lbs ok

Shear Load on Cap Screw

$$V = 520/3 = 173 \text{ lbs}$$

(page 4) V allow = 4000 lbs ok

ANALYSIS OF GLASS RAIL BASE MOLDING ATTACHMENT

WJE Wiss, Janny, Elstner Associates, Inc. 330 Pfingsten Rd., Northbrook Illinois 60062 Morse Industries Kent, Washington Glass Rail Base Molding Attachment Analysis	Made by: NSA	Sheet # 20/21
	Checked by: MJS	Project # 970798
	Date: 07/22/97	

(page 5) Brg. on aluminum with 1/4" min.
 V allow = 3000 lbs
 ok

(page 5) Brg. on aluminum under head for tensile load
 T allow = 3920 lbs ok

Check Allowable Tensile Capacity into R or <

(page 6) Min. Steel Thickness (MT) = 0.56"

for 1/2" Reduction = $.5 / .56 = 0.88$
 T allow = $(7840) (.88) = 6900$ lbs ok

for 3/8" Reduction = $.375 / .56 = 0.67$
 T allow = $(7840) (.67) = 5250$ lbs ok

: As a practical minimum, use 3/8" thick steel

Check screw bearing in Steel Angle

Say t = 3/8" screw $\varnothing = 1/2$ "
 A36 steel Fu = 58 ksi (Ref: AISC Manual)

$V_{\text{brg-allow}} = (3/8") (1/2") (1.2) (58 \text{ ksi})$
 = 13 kips ok (does not control)

ANALYSIS OF GLASS RAIL BASE MOLDING ATTACHMENT

WJE Wiss, Janny, Elstner Associates, Inc. 330 Pfingsten Rd., Northbrook Illinois 60062 Morse Industries Kent, Washington Glass Rail Base Molding Attachment Analysis	Made by: NSA	Sheet # 21/21
	Checked by: MJS	Project # 970798
	Date: 07/22/97	

Case 4 Analysis: Configuration

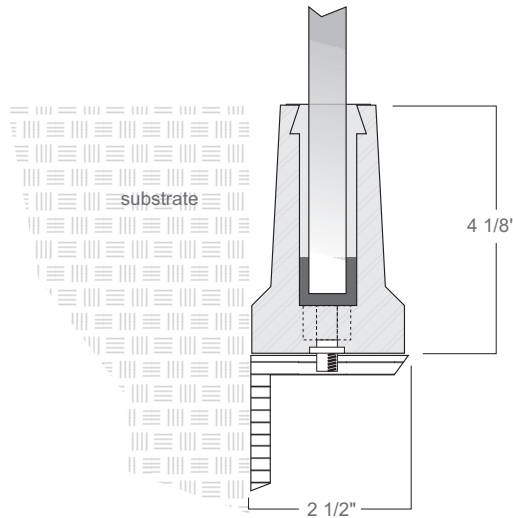

(from page 11 & 13)

M = 9225 in lbs

N = 200 lbs →
DL

P = (3.5') (45)
= 158 lbs ↓

Cap Screw Connection

Arm = (2 1/2) (1/2) = 1 1/4" Again, 3 screws effective

$$T = \frac{M}{\text{Arm}} + \frac{9225}{(3)(1.25)} = 2460 \text{ lbs}$$

(page 4) T allow = 7840 lbs ok

(page 5) T allow = 3920 lbs ok (brg under head)

(page 16) T allow = 5250 lbs ok (3/8" R grip)