

TOLERANCES (Unless otherwise stated)

Decimals	Angles ($\pm 0.2^\circ$)
500 < \leq 2000mm	± 0.20 mm
200 < \leq 500mm	± 0.15 mm
< 200mm	± 0.10 mm
500 < \leq 2000mm	± 0.15 mm
< 500mm	± 0.10 mm

THIRD ANGLE PROJECTION

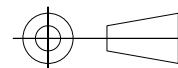

Model No.	6065K+	Scale	1:1	Notes:
Part No.	CTI-6065K+UH20	Rev.	1.0	
Part Name		Size	Free	
Unit	mm	Sheet	1/1	
Material		Chk'd		
Surface		App'd		
Drawn				

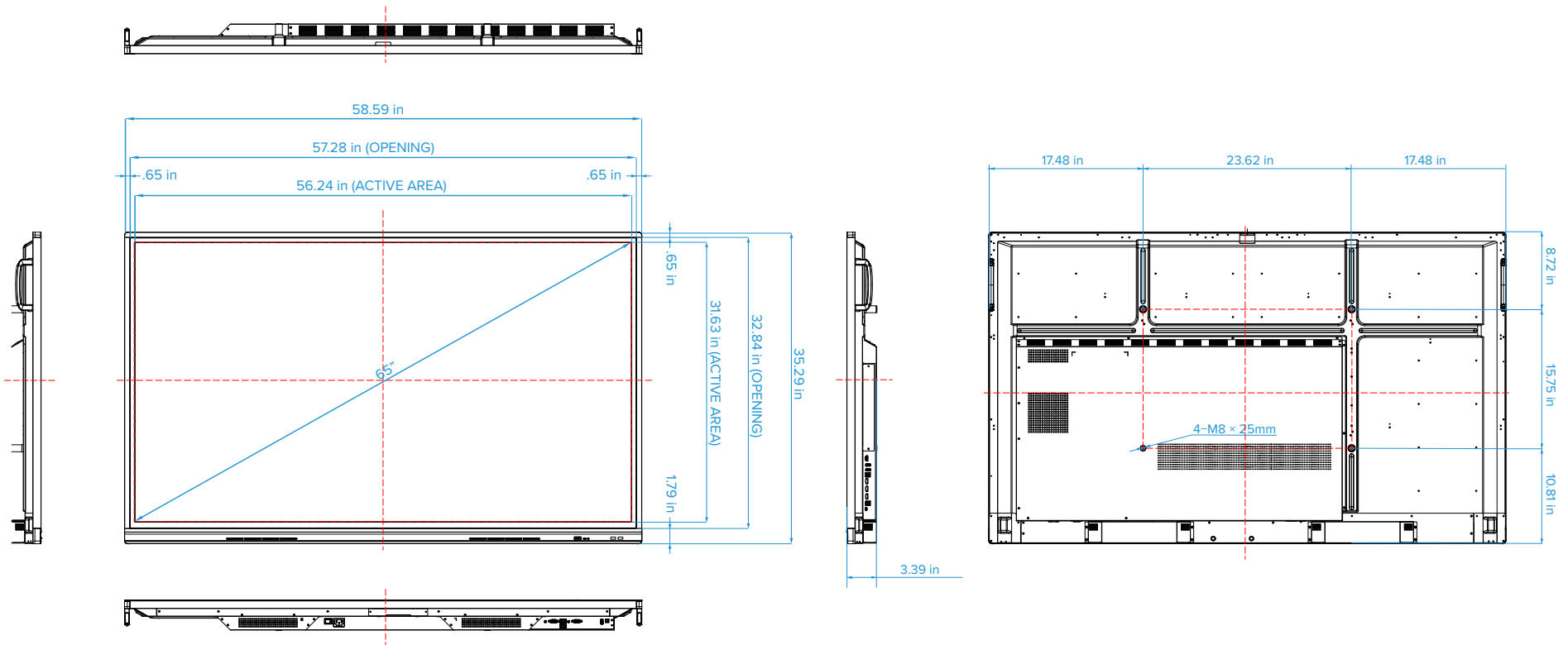

TOLERANCES (Unless otherwise stated)

Decimals	Angles ($\pm 0.2^\circ$)
500 < \leq 2000mm	± 0.20 mm
200 < \leq 500mm	± 0.15 mm
< 200mm	± 0.10 mm
500 < \leq 2000mm	± 0.15 mm
< 500mm	± 0.10 mm

THIRD ANGLE PROJECTION

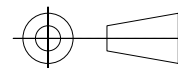

Model No.	6065K+	Scale	1:1	Notes:
Part No.	CTI-6065K+UH20	Rev.	1.0	
Part Name		Size	Free	
Unit	in	Sheet	1/1	
Material		Chk'd		
Surface		App'd		
Drawn				